

# An Introduction to CATIA V5

## Release 12

### (A Hands-On Tutorial Approach)

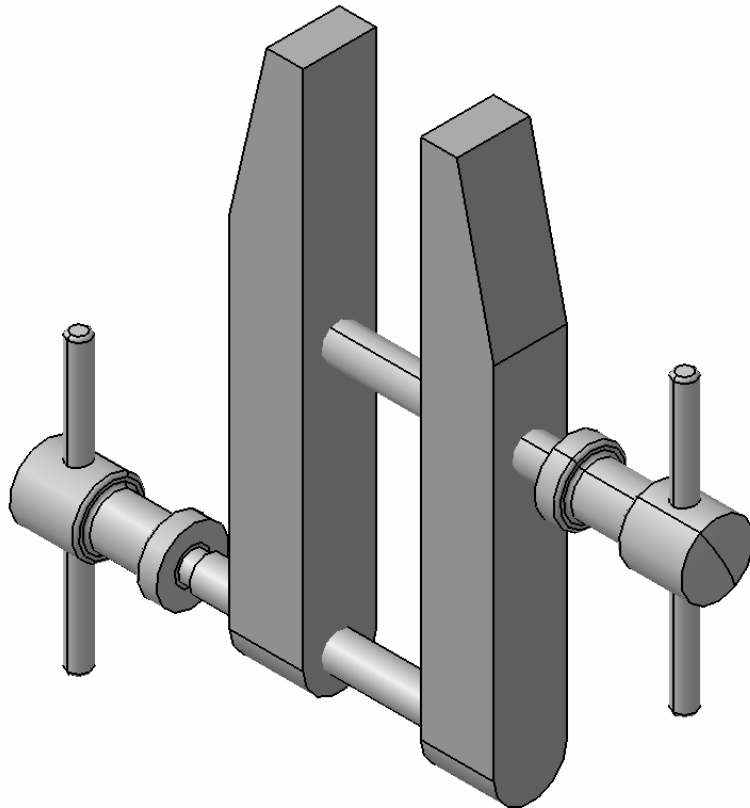
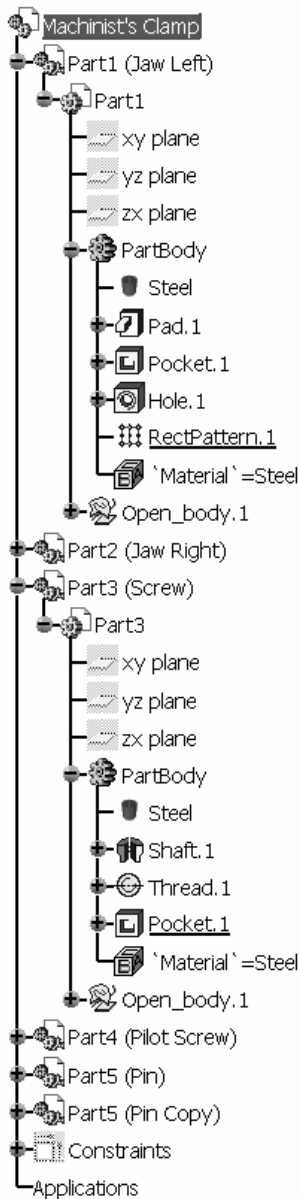

**Kirstie Plantenberg**  
University of Detroit Mercy

**SDC**  
PUBLICATIONS

Schroff Development Corporation

[www.schroff.com](http://www.schroff.com)  
[www.schroff-europe.com](http://www.schroff-europe.com)

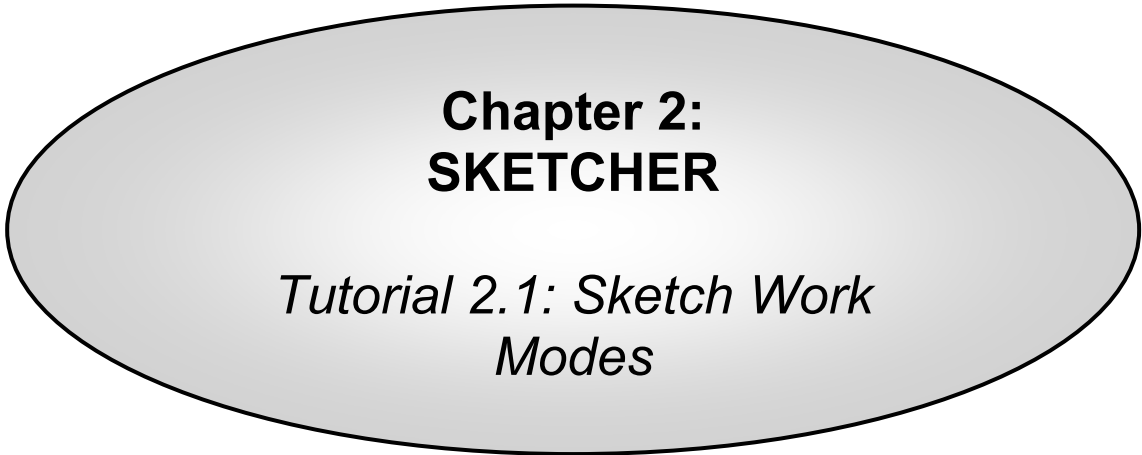

**Chapter 2:  
SKETCHER**

*Tutorial 2.1: Sketch Work  
Modes*

Featured Topics & Commands

The Sketcher workbench	.....	2.1-2
The Sketch tools toolbar	.....	2.1-3
Part Modeled	.....	2.1-3
Section 1: Using Snap to Point	.....	2.1-4
Section 2: Using Construction Elements	.....	2.1-6
Section 3: Geometrical and Dimensional Constraints	.....	2.1-8
Section 4: Cutting the part by the sketch plane	.....	2.1-10

Prerequisite Knowledge & Commands

- Entering workbenches
- Entering and exiting the *Sketcher* workbench
- Drawing simple profiles
- Simple Pads and Pockets

## The Sketcher Workbench

The *Sketcher* workbench is a set of tools that helps you create and constrain 2D geometries. Features (pads, pockets, shafts, etc...) may then be created solids or modifications to solids using these 2D profiles. You can access the *Sketcher* workbench in various ways. Two simple ways are by using the top pull down

menu (Start – Mechanical Design – Sketcher), or by selecting the *Sketcher*  icon. When you enter the sketcher, CATIA requires that you choose a plane to sketch on. You can choose this plane either before or after you select the

*Sketcher* icon. To exit the sketcher, select the *Exit Workbench*  icon.

The *Sketcher* workbench contains the following standard workbench specific toolbars.

- **Profile toolbar:** The commands located in this toolbar allow you to create simple geometries (rectangle, circle, line, etc...) and more complex geometries (profile, spline, etc...).



- **Operation toolbar:** Once a profile has been created, it can be modified using commands such as trim, mirror, chamfer, and other commands located in the *Operation* toolbar.



- **Constraint toolbar:** Profiles may be constrained with dimensional (distances, angles, etc...) or geometrical (tangent, parallel, etc...) constraints using the commands located in the *Constraint* toolbar.



- **Sketch tools toolbar:** The commands in this toolbar allow you to work in different modes which make sketching easier.

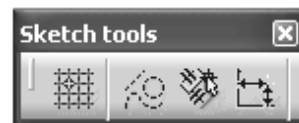

- **User Selection Filter toolbar:** Allows you to activate different selection filters.



- **Tools toolbar:** Allows you to, among others other things, to analyze a sketch for problems, cut the part by the sketch plane, and create a datum.



## The Sketch tools Toolbar

The *Sketch tools* toolbar contains icons that activate and deactivate different work modes. These work modes assist you in drawing 2D profiles. Reading from left to right, the toolbar contains the following work modes; (Each work mode is active if the icon is orange and inactive if it is blue.)

- Snap to Point: If active, your cursor will snap to the intersections of the grid lines.
- Construction / Standard Elements: You can draw two different types of elements in CATIA a standard element and a construction element. A standard element (solid line type) will be created when the icon is inactive (blue). It will be used to create a feature in the *Part Design* workbench. A construction element (dashed line type) will be created when the icon is active (orange). They are used to help construct your sketch, but will not be used to create features.
- Geometric Constraints: When active, geometric constraints will automatically be applied such as tangencies, coincidences, parallelisms, etc...
- Dimensional Constraints: When active, dimensional constraints will automatically be applied when corners (fillets) or chamfers are created, or when quantities are entered in the value field. The value field is a place where dimensions such as line length and angle are manually entered.



## Part Modeled

The part modeled in this tutorial is shown below. The part is constructed with the assistance of different work modes.

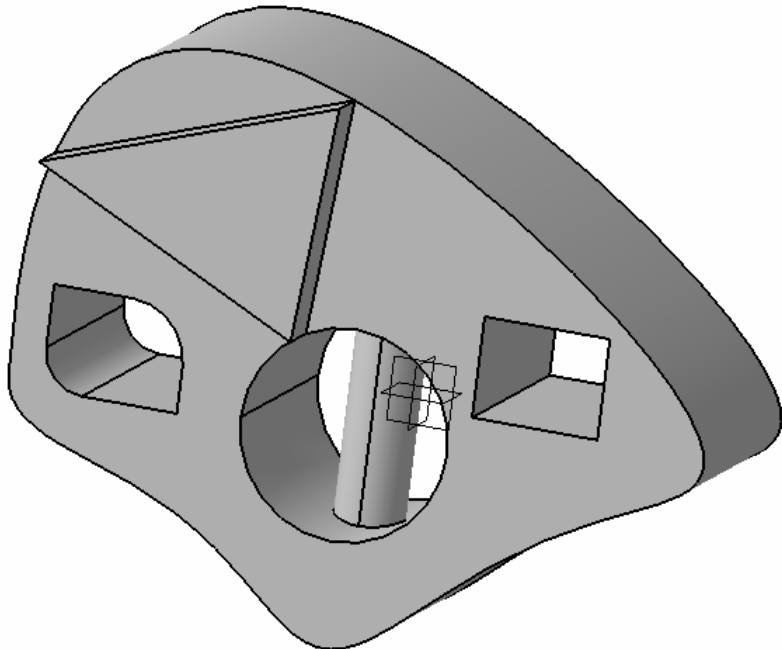

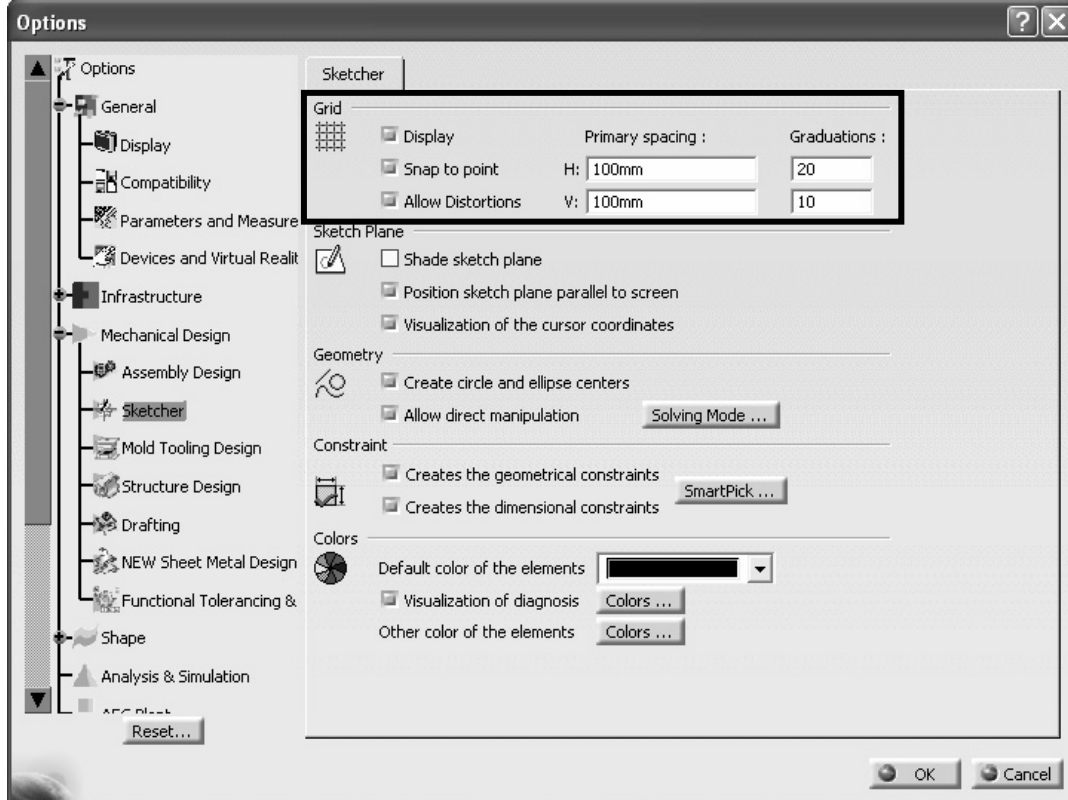

## Section 1: Using Snap to Point

- 1) Enter the **Sketcher**  on the **yz plane**.
- 2) Restore the default positions of the toolbars (**Tools – Customize... – Toolbars** tab – **Restore position**.) Move the *Sketch Tools* toolbar and the *User Selection Filter* toolbar to the top toolbar area.
- 3) Set your grid spacing. At the top pull down menu, select **Tools – Options...** In the *Options* window, expand the Mechanical Design portions of the left side navigation tree and select **Sketcher**. Activate the options *Display*, *Snap to point*, and *Allow Distortions* in the Grid section on the right side. Set your Primary spacing and Graduations to H: **100 mm** and **20**, and V: **100 mm** and **10**.



- 4) Select the **Spline**  icon. This is located in the *Profile* toolbar in the right side toolbar area.

5) Move your cursor around the screen. Note that it snaps to the intersections of the grid. Your *Snap to Point*  should be orange (active). Deactivate the **Snap to Point**  icon by clicking on it and turning it back to blue. Move your cursor around the screen and notice the difference.

6) Reactivate the **Snap to Point**  icon and draw the spline shown. Select each point (indicated by a square) in order from 1 to 7, double clicking at the last point to end the spline command.

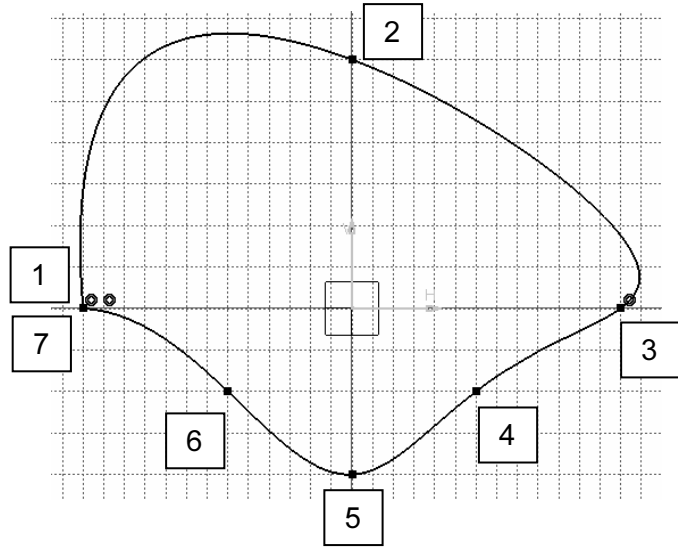

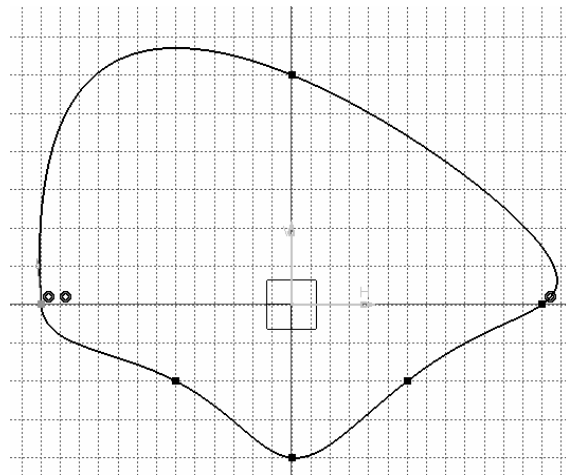
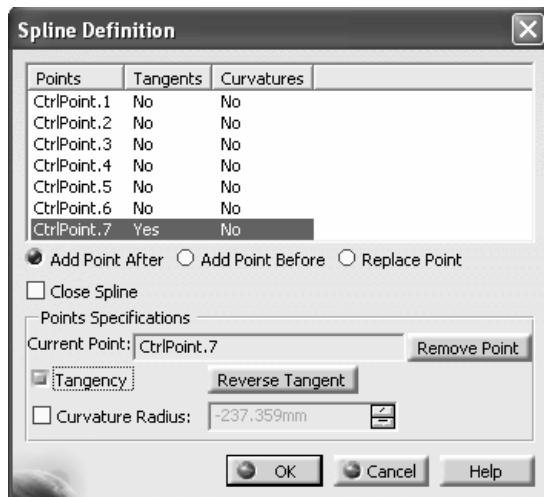

7) Edit the spline by double clicking on any portion of it.

8) In the *Spline Definition* window, select **CtrlPoint.7**, then activate the **Tangency** option, and select **OK**. Notice that the last point is now tangent to the first point.



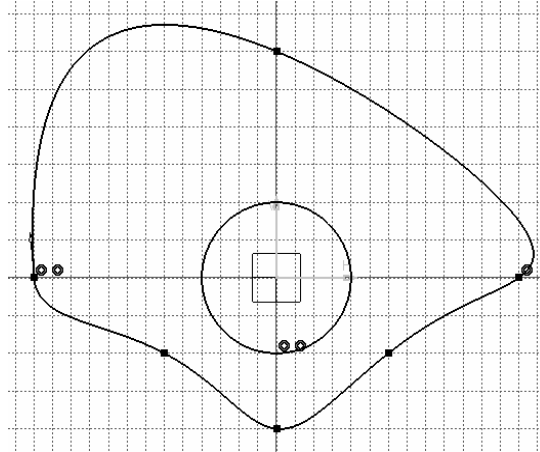

9) Draw a **Circle**  inside the spline as shown.



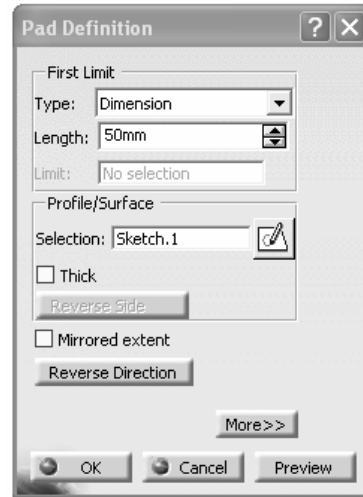
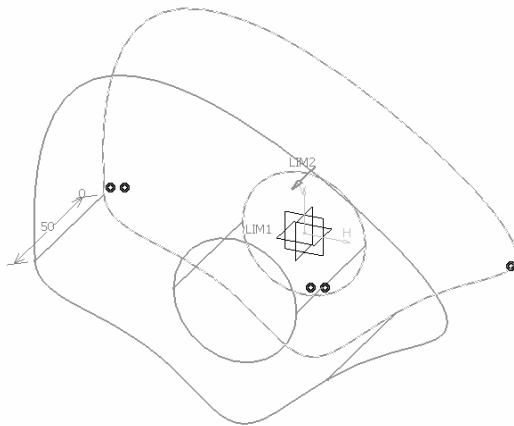

10) **Exit** the Sketcher  and **Pad**  the sketch to a length of **50 mm**.

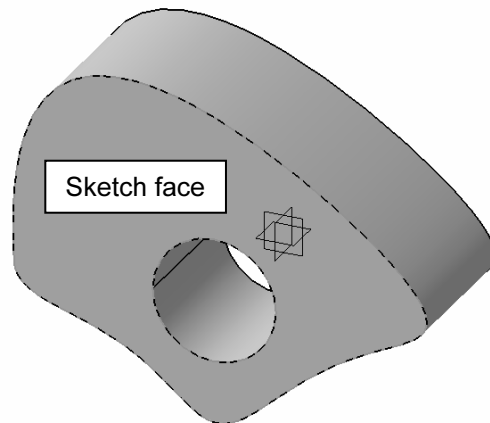

**Section 2: Using construction elements.** 

- 1) Enter the **Sketcher**  on the front face of the part.
- 2) Activate the **Construction / Standard Elements**  icon. It should be orange.
- 3) Deselect all. Hit the **Esc** key twice.



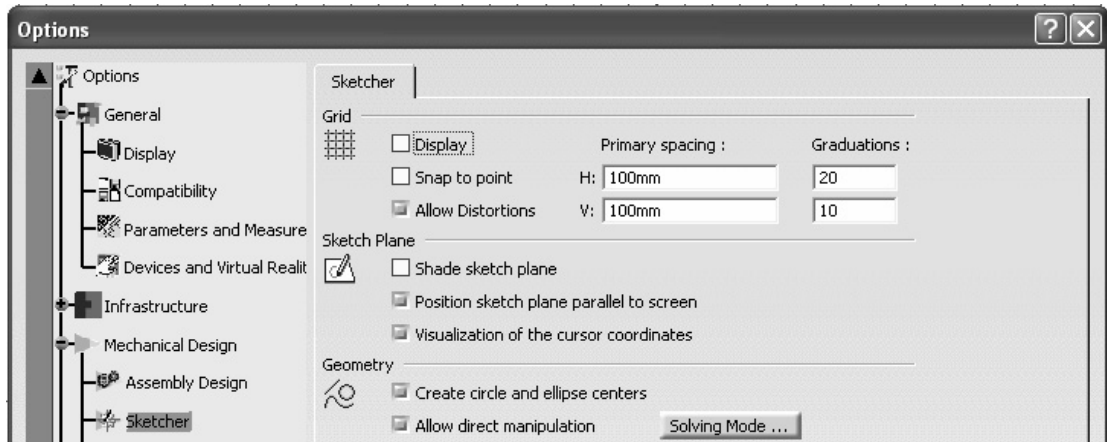

- 4) Project an outline of the part onto the sketch plane. Select the **Project 3D Elements**  icon then select the face of the part. This icon is located near the bottom of the right side toolbar area.
- 5) Deselect all. The projection should now be yellow (this means it is associated with the part and will change with the part) and dashed (this means it is a construction element).
- 6) At the top pull down window, select **Tools – Options – Sketcher** tab. Deactivate the Grid **Display** and **Snap to Point** options. Select **OK**.



- 7) Deactivate the **Construction / Standard Elements**  icon.

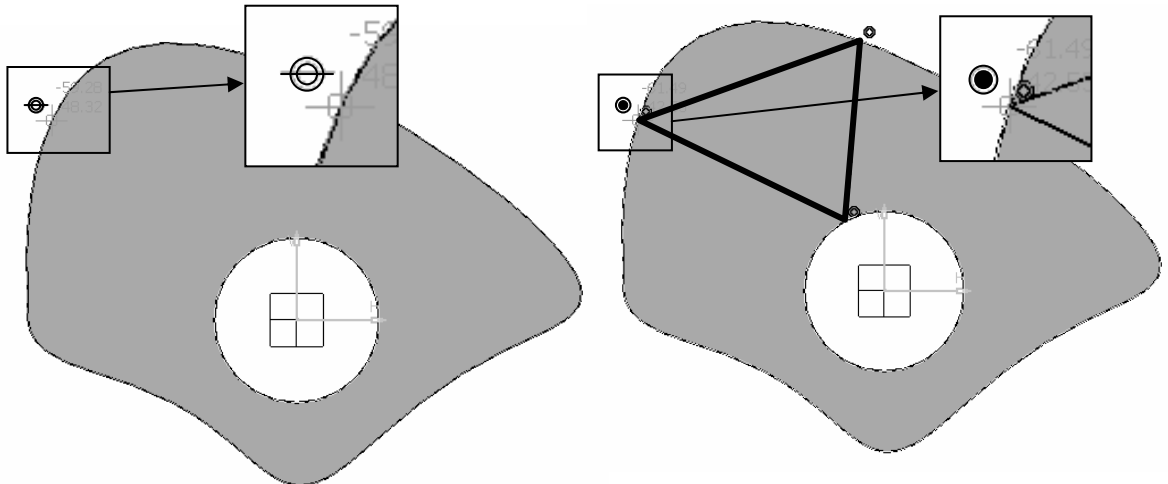

- 8) Using the **Profile**  command to draw the triangle shown. The points of the triangle should lie on the projected construction element. You will know when you are on the projection when a symbol of two concentric circles appears, and you will know when you are snapped to the endpoint of the start point when a symbol of two concentric circles appears and the inner one is filled.

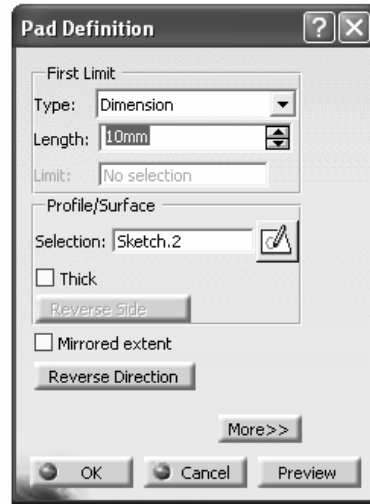
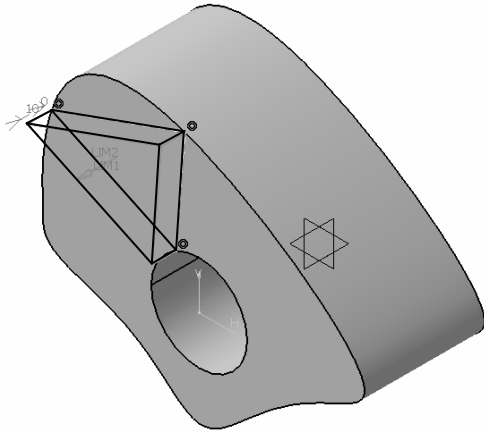

- 9) Exit the Sketcher  and Pad  the sketch to a length of **10 mm**.



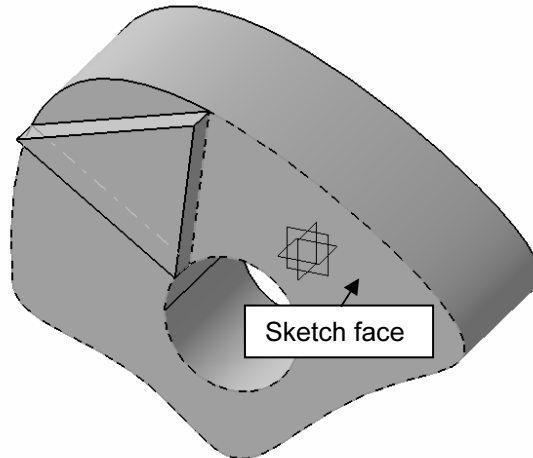

### Section 3: Geometrical and Dimensional Constraints

- 1) Enter the **Sketcher**  on the front large face of the part.
- 2) Activate the **Geometrical Constraints**  icon. It should be orange.

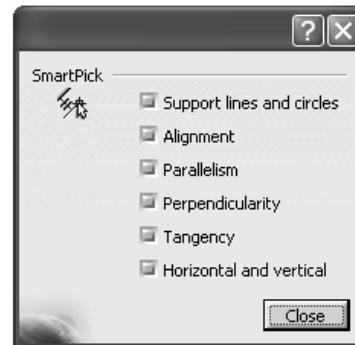
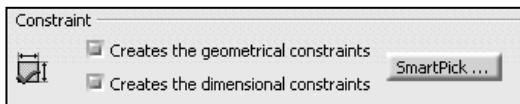

- 3) At the top pull down window, select **Tools - Options - Sketcher**. Under the Constraint portions of the window, select **SmartPick...** The *SmartPick* window shows all the geometrical constraints that will be created automatically. These constraints may be turn on and off depending on your design/sketch needs. **Close** both the *Smart Pick* and *Options* windows.



4) Draw a **Rectangle**  to the right of the hole as shown. Notice that geometric constraints (H = horizontal, V = Vertical) are automatically applied.

5) Deactivate the **Geometrical Constraints**  icon. It should be blue.

6) Draw a **Rectangle**  to the left of the hole as shown. Notice that no geometric constraints are made.

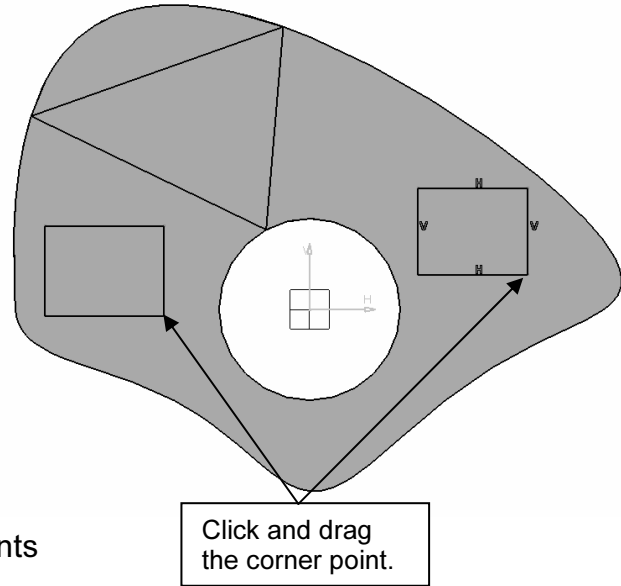

7) For each rectangle, click on one of the points defining a corner and move it using the mouse. Notice the difference between the two. This is due to the horizontal and vertical constraints that were applied to the one rectangle.

8) Undo (**CTRL + Z**) the moves until the original rectangles are back.

9) **Exit** the Sketcher  and **Pocket**  the sketch using the **Up to last** option.

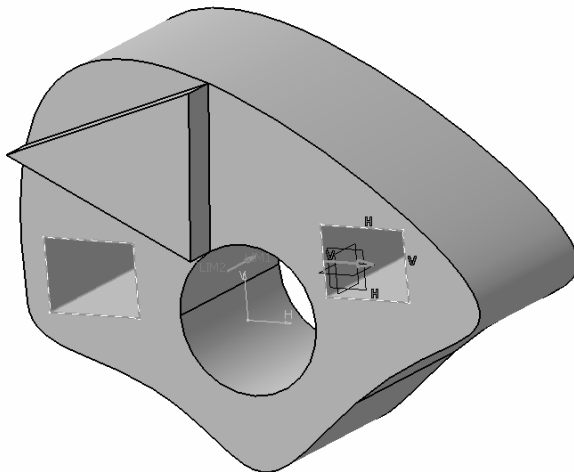

10) Expand the specification tree to the sketch level.

11) Edit Sketch.3 (the sketch associated with the pocket). In the specification tree, double click on **Sketch.3**, or right click on it and select **Sketch.3 object - Edit**. You will automatically enter the sketcher on the sketch plane used to create this sketch.

12) Activate the **Dimensional Constraint**  icon. It should be orange.

13) Select the **Corner**  icon, select the bottom left corner point of the left rectangle, move your mouse up and to the right, and click. A corner or fillet will be created. The corner icon is located in the *Operations* toolbar near the bottom of the right side toolbar area. The corner/fillet may also be created by selecting the two lines that create the corner. Notice that a dimension is automatically created.

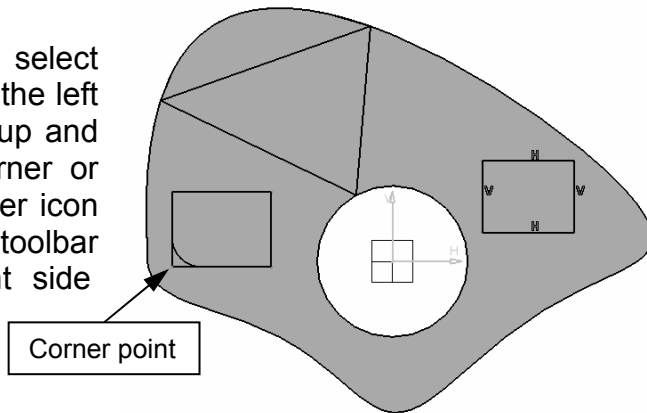

14) Deactivate the **Dimensional Constraint**  icon. It should be blue.

Create a **Corner**  in the upper right corner of the same rectangle. Notice that this time no dimensional constraint was created.

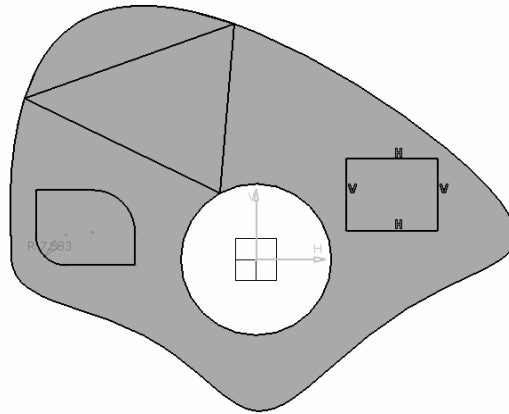

15) **Exit** the Sketcher . We have changed the sketch used to create the pocket. Notice that the pocket is automatically updated to reflect these changes.

#### **Section 4: Cutting the part by the sketch plane.**

Sometimes it is necessary to sketch inside the part. The *Cut Part by Sketch Plane* command allows you to see inside the part and makes it easier to draw and constrain your sketch.

1) Enter the **Sketcher**  on the **xy plane**.

2) Select the **Isometric View**  icon. This icon is located in the bottom toolbar area.

3) Select the **Cut Part by Sketch**

**Plane**  icon located in the bottom toolbar area. The part is now cut by the xy plane (the sketch plane).

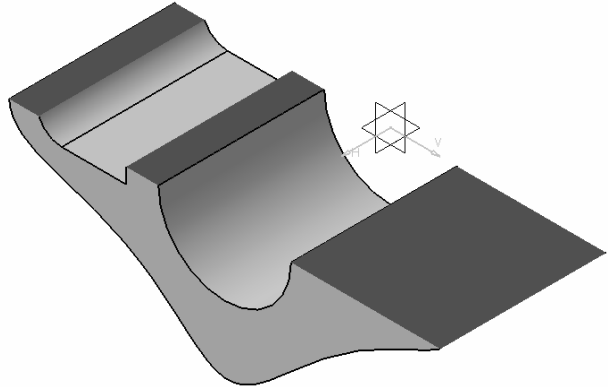

4) Select the **Top view**  icon

and draw a **Circle**  in the middle of the hole as shown in the figure.

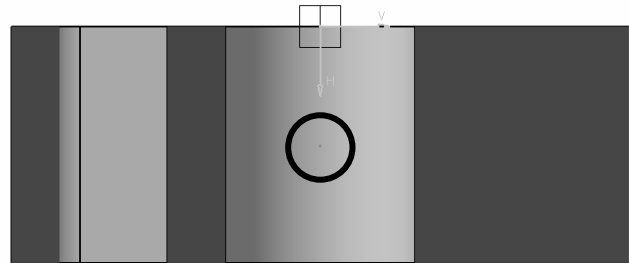

5) **Exit** the Sketcher .

6) Select the **Pad**  icon and then select the **More>>** button. Fill in the following fields for both the First and Second Limits; Type: **Up to surface**, Limit: **Pocket.1\Face.1**, Offset: **0mm**; Type: **Up to surface**, Limit: **Pocket.1\Face.2**, Offset: **0mm**; Profile/Surface Selection: **Sketch.4** (the circle). Select **Preview** to see if the Pad will be applied correctly, and then **OK**.

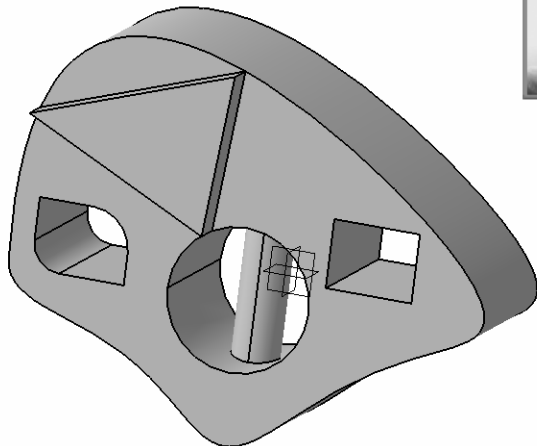

NOTES:

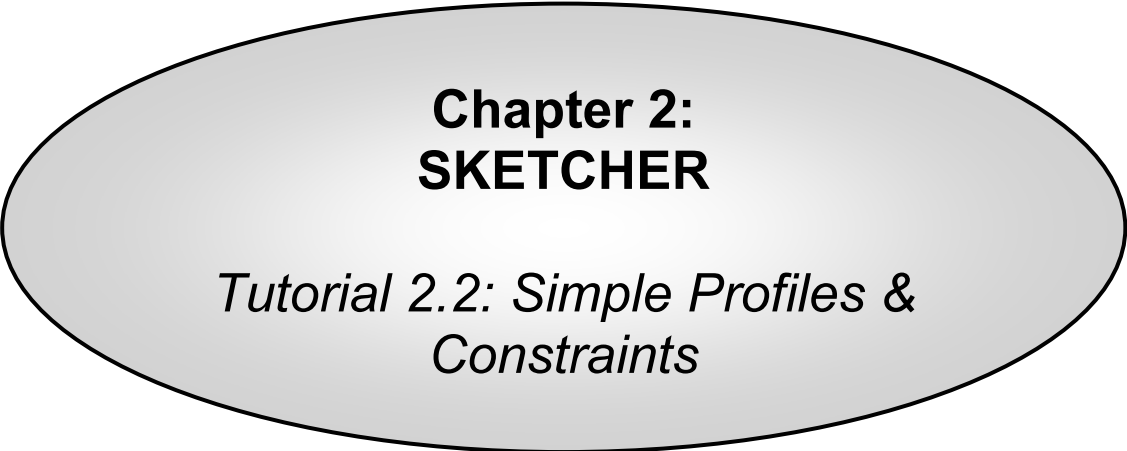

**Chapter 2:  
SKETCHER**

*Tutorial 2.2: Simple Profiles &  
Constraints*

Featured Topics & Commands

Profile toolbar	.....	2.2-2
Constraints toolbar	.....	2.2-5
Selecting icons	.....	2.2-5
Part Modeled	.....	2.2-6
Section 1: Creating circles.	.....	2.2-6
Section 2: Creating dimensional constraints.	.....	2.2-7
Section 3: Creating lines.	.....	2.2-8
Section 4: Creating geometrical constraints.	.....	2.2-11
Section 5: Creating arcs.	.....	2.2-14

Prerequisite Knowledge & Commands

- Entering workbenches
- Entering and exiting the *Sketcher* workbench
- Simple Pads
- Work modes (Sketch tools toolbar)

## Profile toolbar

The *Profile* toolbar contains 2D geometry commands. These geometries range from the very simple (point, rectangle, etc...) to the very complex (splines, conics, etc...). The *Profile* toolbar contains many sub-toolbars. Most of these sub-toolbars contain different options for creating the same geometry. For example, you can create a simple line, a line defined by two tangent points, or a line that is perpendicular to a surface. Reading from left to right, the *Profile* toolbar contain the following commands.

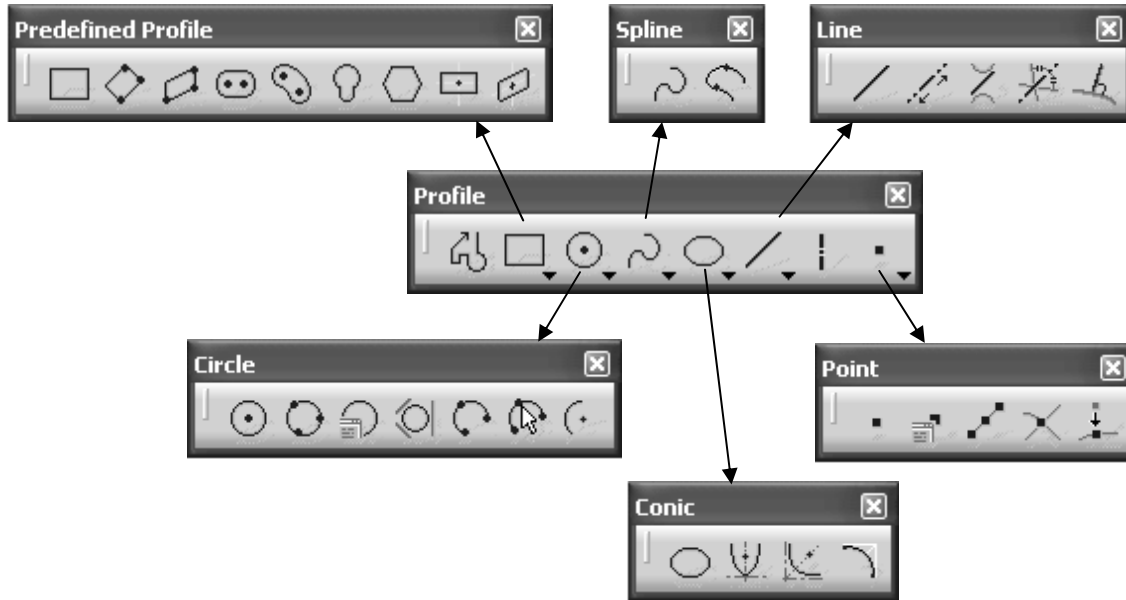

## Profile toolbar

- Profile: This command allows you to create a continuous set of lines and arcs connected together.
- Rectangle / Predefined Profile toolbar: The default top command is *rectangle*. Stacked underneath are several different commands used to create predefined geometries.
- Circle / Circle toolbar: The default top command is *circle*. Stacked underneath are several different options for creating circles and arcs.
- Spline / Spline toolbar: The default top command is *spline* which is a curved line created by connecting a series of points.
- Ellipse / Conic toolbar: The default top command is *ellipse*. Stacked underneath are commands to create different conic shapes such as a hyperbola.
- Line / Line toolbar: The default top command is *line*. Stacked underneath are several different options for creating lines.
- Axis: An axis is used in conjunction with commands like mirror and shaft (revolve). It defines symmetry. It is a construction element so it does not become a physical part of your feature.

- Point / Point toolbar: The default top command is *point*. Stacked underneath are several different options for creating points.

### Predefined Profile toolbar

Predefined profiles are frequently used geometries. CATIA makes these profiles available for easy creation which speeds up drawing time. Reading from left to right, the *Predefined Profile* toolbar contains the following commands.

- Rectangle: The *rectangle* is defined by two corner points. The sides of the rectangle are always horizontal and vertical.
- Oriented Rectangle: The *oriented rectangle* is defined by three corner points. This allows you to create a rectangle whose sides are at an angle to the horizontal.
- Parallelogram: The *parallelogram* is defined by three corner points.
- Elongated Hole: The elongated hole or slot is defined by two points and a radius.
- Cylindrical Elongated Hole: The *cylindrical elongated hole* is defined by a cylindrical radius, two point and a hole radius.
- Keyhole Profile: The *keyhole profile* is defined by two center points and two radii.
- Hexagon: The *hexagon* is defined by a center point and the radius of an inscribed circle.
- Centered Rectangle: The *centered rectangle* is defined by a center point and a corner point.
- Centered Parallelogram: The *centered parallelogram* is defined by a center point (defined by two intersecting lines) and a corner point.



### Circle toolbar

The *Circle* toolbar contains several different ways of creating circles and arcs. Reading from left to right, the *Circle* toolbar contains the following commands.

- Circle: A *circle* is defined by a center point and a radius.
- Three Point Circle: The *three point circle* command allows you to create a circle using three circumferential points.
- Circle Using Coordinates: The *circle using coordinates* command allows you to create a circle by entering the coordinates for the center point and radius in a *Circle Definition* window.
- Tri-Tangent Circle: The *tri-tangent circle* command allows you to create a circle whose circumference is tangent to three chosen lines.



- Three Point Arc: The *three point arc* command allows you to create an arc defined by three circumferential points.
- Three Point Arc Starting With Limits: The *three point arc starting with limits* allows you to create an arc using a start, end, and midpoint.
- Arc: The *arc* command allows you to create an arc defined by a center point, and a circumferential start and end point.

### Spline toolbar

Reading from left to right, the *Spline* toolbar contains the following commands.

- Spline: A spline is a curved profile defined by three or more points. The tangency and curvature radius at each point may be specified.
- Connect: The connect command connects two points or profiles with a spline.



### Conic toolbar

Reading from left to right, the *Conic* toolbar contains the following commands.

- Ellipse: The ellipse is defined by center point and a major and minor axis points.
- Parabola by Focus: The parabola is defined by a focus, apex and a start and end point.
- Hyperbola by Focus: The hyperbola is defined by a focus, center point, apex and a start and end point.
- Conic: There are several different methods that can be used to create conic curves. These methods give you a lot of flexibility when creating above three types of curves.



### Line toolbar

The *Line* toolbar contains several different ways of creating lines. Reading from left to right, the *Line* toolbar contains the following commands.

- Line: A line is defined by two points.
- Infinite Line: Creates infinite lines that are horizontal, vertical or defined by two points.
- Bi-Tangent Line: Creates a line whose endpoints are tangent to two other elements.
- Bisecting Line: Creates an infinite line that bisects the angle created by two other lines.
- Line Normal to Curve: This command allows you to create a line that starts anywhere and ends normal or perpendicular to another element.



## Point toolbar

The *Point* toolbar contains several different ways of creating points. Reading from left to right, the *Point* toolbar contains the following commands.

- Point by Clicking: Creates a point by clicking the left mouse button.
- Point by using Coordinates: Creates a point at a specified coordinate point.
- Equidistant Points: Creates equidistant points along a predefined path curve.
- Intersection Point: Creates a point at the intersection of two different elements.
- Projection Point: Projects a point of one element onto another.



## Constraints toolbar

Constraints can either be dimensional or geometrical. Dimensional constraints are used to constrain the length of an element, the radius or diameter of an arc or circle, and the distance or angle between elements. Geometrical constraints are used to constrain the orientation of one element relative to another. For example, two elements may be constrained to be perpendicular to each other. Other common geometrical constraints include parallel, tangent, coincident, concentric, etc...

- Constraints Defined in Dialoged Box: Creates geometrical and dimensional constraints between two elements.
- Constraint: Creates dimensional constraints.
- Auto Constraint: Automatically creates dimensional constraints.
- Animate Constraint: Animates a dimensional constraint between to limits.

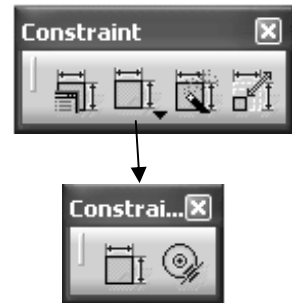

## Selecting icons

When an icon is selected, it turns orange indicating that it is active. If the icon is activated with a single mouse click, the icon will turn back to blue (deactivated) when the operation is complete. If the icon is activated with a double mouse click, it will remain active until another command is chosen or if the Esc key is hit twice.

## Part Modeled

The part modeled in this tutorial is shown on the right. This part will be created using simple profiles, circles, arcs, lines, and hexagons. The geometries are constrained to conform to certain dimensional (lengths) and geometrical constraints (tangent, perpendicular, etc...).

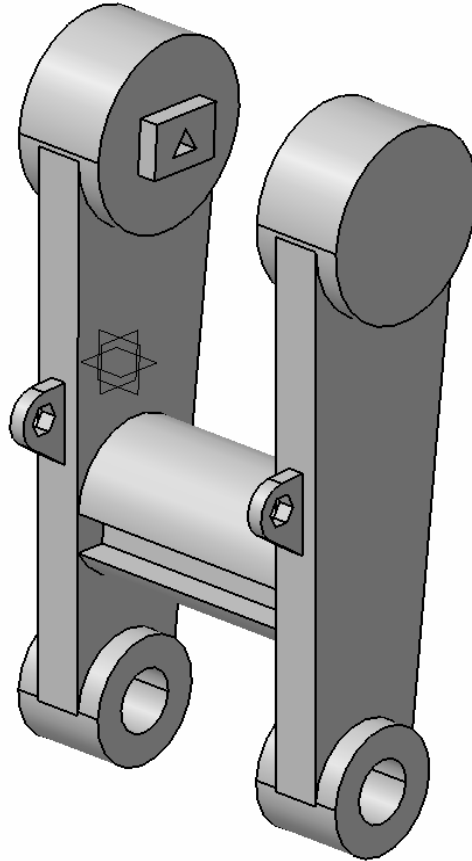

### Section 1: Creating circles.

(Hint: If you get confused about how to apply the different commands that are used in this tutorial, read the prompt line for additional help.)

- 1) Launch **CATIA V5** and enter the **Part Design** workbench.
- 2) Enter the **Sketcher**  on the **zx plane**.
- 3) Set your grid spacing to be **100 mm** with **10** graduations, activate the *Snap to point*, and activate the *geometrical* and *dimensional* constraints. (**Tools – Options...**)

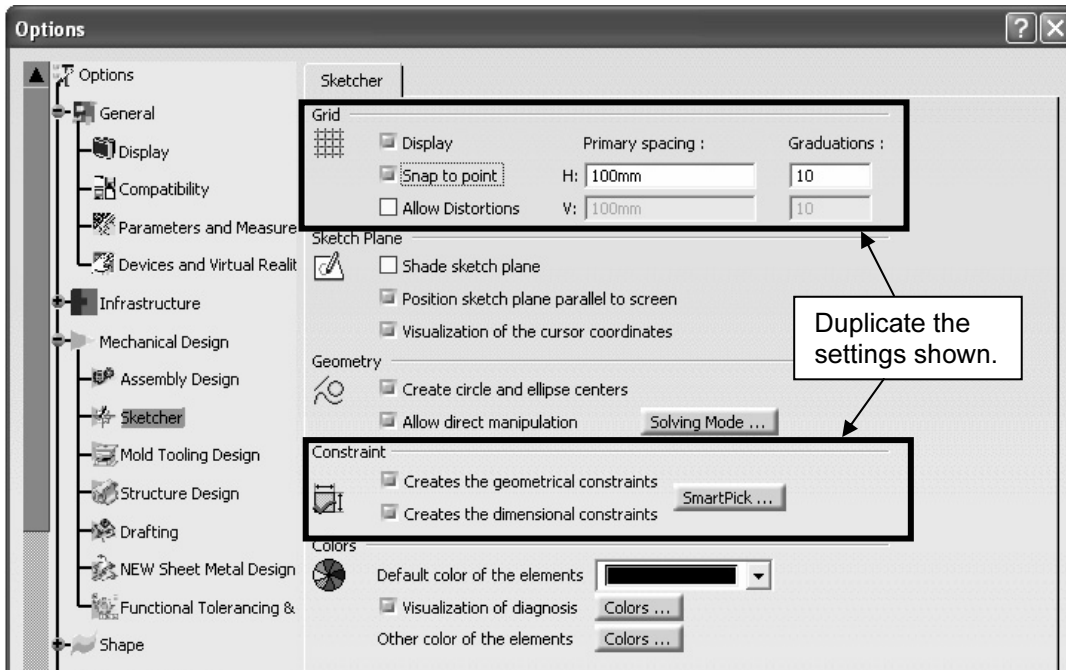

4) Double click on the **Circle**  icon and draw the circles shown.

5) **Exit** the Sketcher



and **Pad**



the sketch to **12 mm** on each side (**Mirrored extent**). Notice that the inner circle at the bottom becomes a hole.

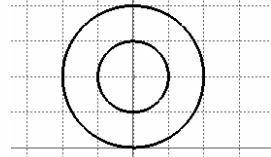
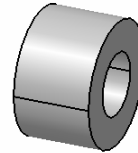
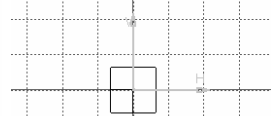
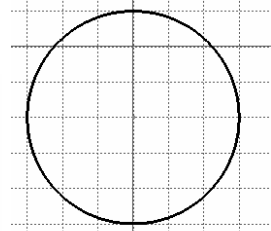
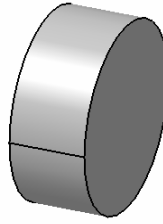
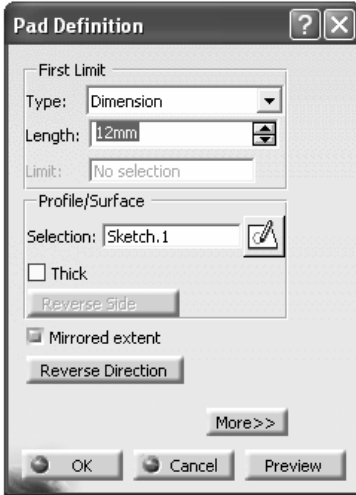

## **Section 2: Creating dimensional constraints.**

1) Expand your specification tree to the sketch level.

2) Edit Sketch.1. To edit a sketch you can double click on the sketch name in the specification tree, or you can *right click* on the name select **Sketch.1 - Edit**. CATIA automatically takes you into the sketcher on the plane used to create Sketch.1.

3) Double click on the **Constraints**  icon.

4) Select the border of the upper circle, pull the dimension out and click your left mouse button to place the dimension. Repeat for the two bottom circles.

5) Select the center point of the upper circle, then the center point of the lower circles, pull the dimension out and click.

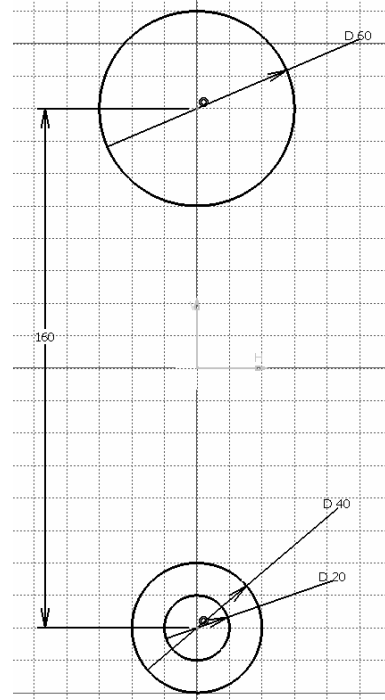

- 6) Double click on the **D20** dimension. In the Constraint Definition window, change the diameter from 20 to **16 mm**.





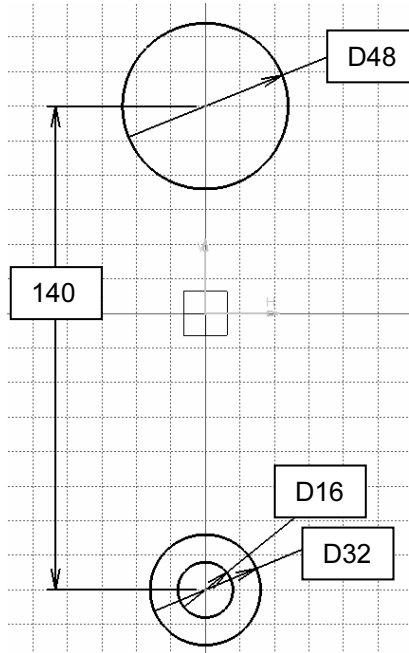

- 7) In a similar fashion, change the other dimensions as shown in the figure.



- 8) **Exit** the Sketcher  and deselect all. Notice that the part automatically updates to the new sketch dimensions.





**Section 3: Creating lines.**

- 1) Enter the **Sketcher**  on the **zx plane**.
- 2) Deactivate the **Snap to Point**  icon.
- 3) Project the two outer circles of the part onto the sketch plane. Double click on the **Project 3D Elements**  icon. This icon is located in the lower half of the right side toolbar area. Select the outer edges of the two cylinders.

- 4) Double click on the **Bi-Tangent Line**  icon. Select the points, in order, as indicated on the figure.

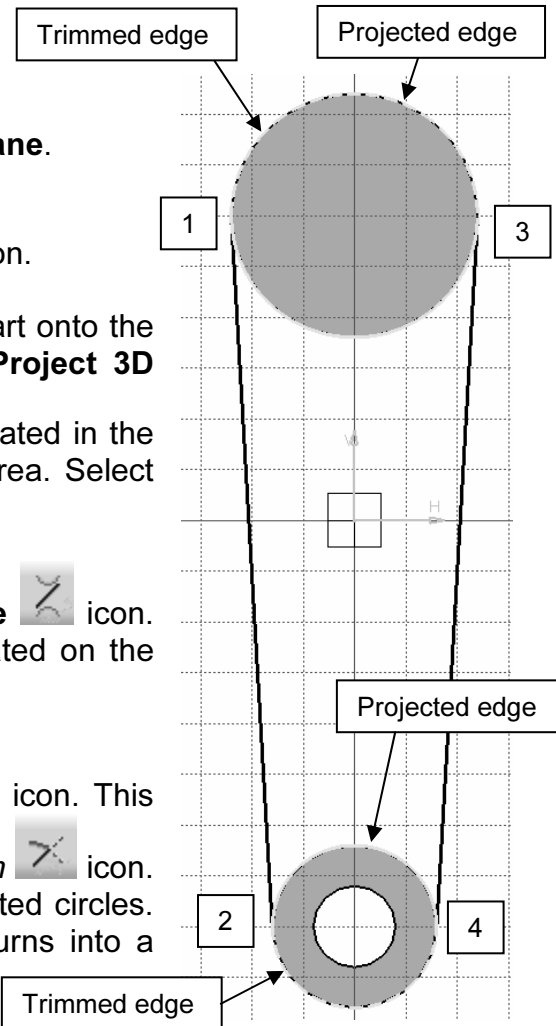
- 5) Double click on the **Quick trim**  icon. This icon is usually stacked under the **Trim**  icon. Select the outer portion of the projected circles. Notice that the trimmed projection turns into a construction element (dashed).





6) **Exit** the Sketcher  and **Pad**  the sketch to **6 mm** on each side (**Mirrored extent**).

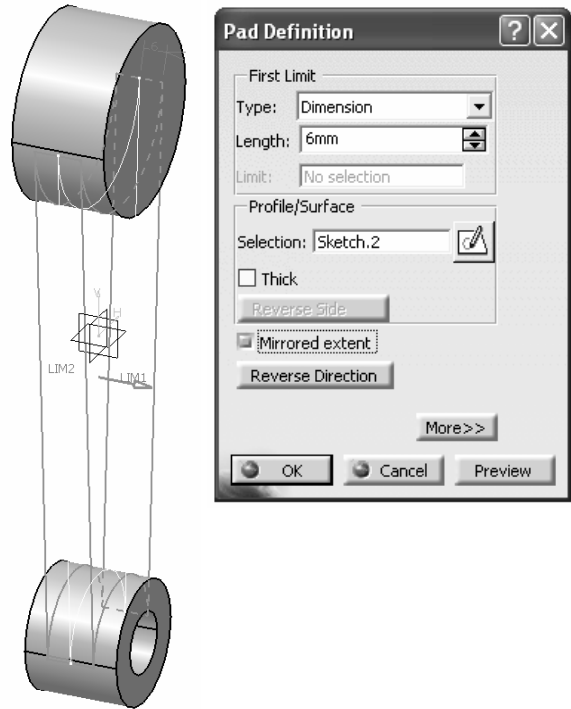

7) Enter the **Sketcher**  on the **zx plane**.

8) Activate the **Construction/Standard Element**  icon (it should be orange).

9) Select the **Project 3D Elements**  icon and then project the left line of the part as shown in the figure.



10) Activate your **Snap to Point**  icon.

11) Draw a line that starts at point 1 (see fig.) and ends normal/perpendicular to projected line using the **Line Normal to Curve**  icon. This icon is usually stacked under the **Line**  icon.

12) Deactivate your **Snap to Point**  icon.

13) Draw a **Line**  from point 1 to point 2.

14) Draw a line that bisects the previous 2 lines using the **Bisecting Line**  icon.

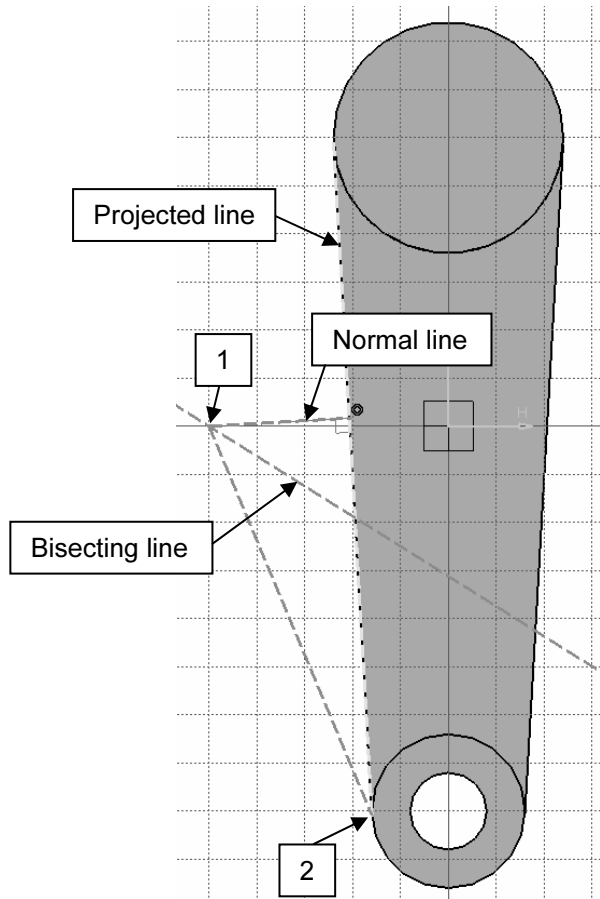

15) Deactivate the **Construction/Standard Element**  icon (it should be blue).

16) Draw a circle that is tangent to the projected line, normal line and bisecting line using the **Tri-Tangent Circle**  icon.

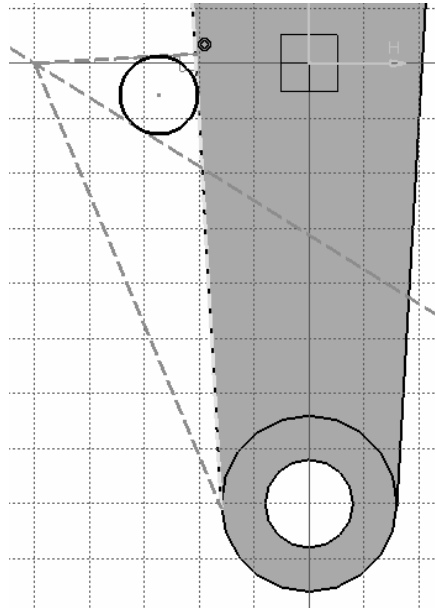

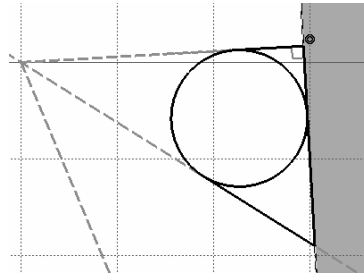

17) Using **Profile** , draw the three additional lines shown in the figure.

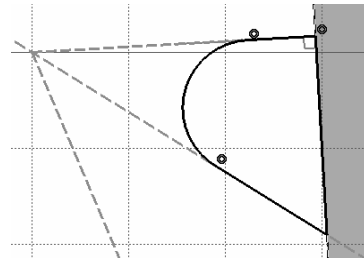

18) Use the Quick Trim command to trim off the inside portion of the circle as shown. You will have to apply the quick trim operation twice.



19) Draw a **Hexagon**  that has the same center as the circle/arc and is the approximate size shown in the figure. The *Hexagon* icon is usually stacked under the *Rectangle*  icon.

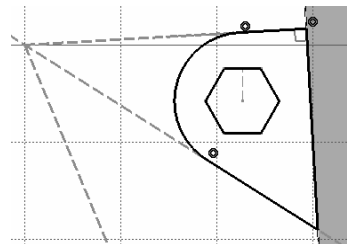

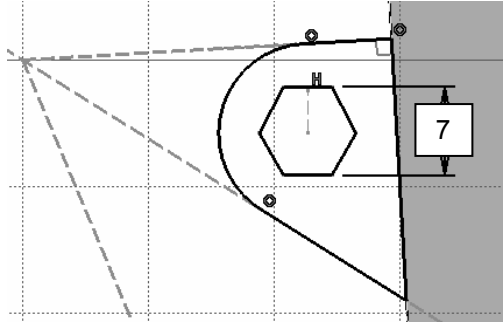

20) Right click on the top line of the hexagon. Select **Line.11 object - Horizontal** (note that the number following Line may be different). Notice a horizontal constraint is applied. This is indicated by the H symbol.





21) Deselect all.

22) Apply a dimensional **Constraint**  to the distance between the flats of the hexagon as shown. Double click on the dimension and change its value to **7 mm**.

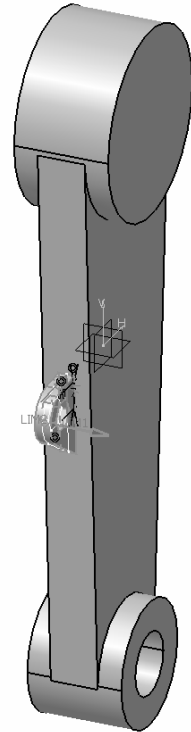
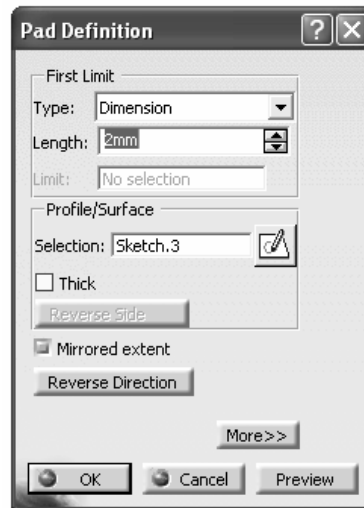
23) **Exit** the Sketcher  and **Pad**  the sketch to a length of **2 mm** on each side (**Mirrored extent**).



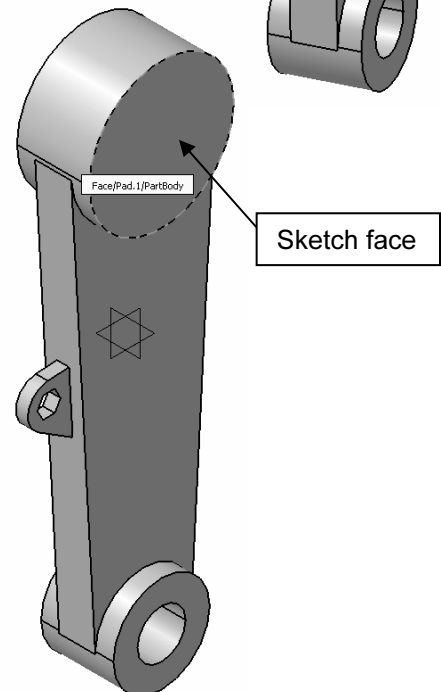

**Section 4: Creating geometrical constraints.**

- 1) Enter the **Sketcher**  on the flat face of the large cylinder.
- 2) Deactivate the **Geometrical Constraint**  icon (it should be blue).

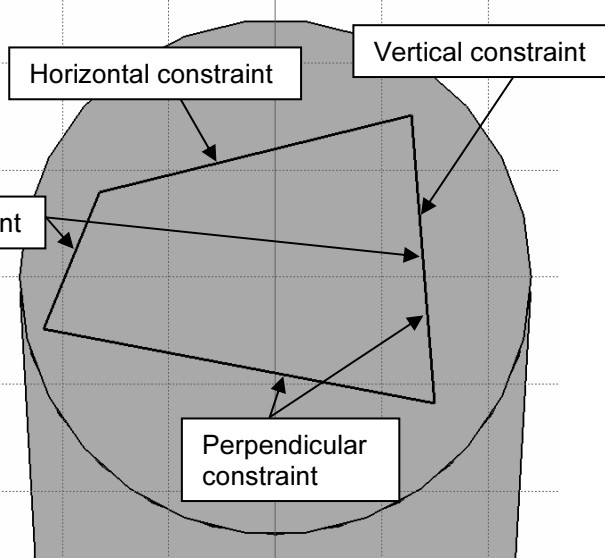

- 3) On the face of the large cylinder, draw the **Profile**  shown. No geometrical constraints should be indicated.



- 4) Reactivate the **Geometrical Constraints**  icon (it should be orange).

- 5) Apply a vertical constraint to the right line of the profile by right clicking on it and selecting **Line.? object – Vertical**.

- 6) Apply a horizontal constraint to the top line using a similar procedure.

- 7) Apply a perpendicular constraint between the right and bottom line of the profile. Hold the CTRL key down and select the left and bottom lines. Select the **Constraints Defined in Dialog Box**  icon. In the *Constraint Definition* window, check the box next to **Perpendicular** and then select **OK**.

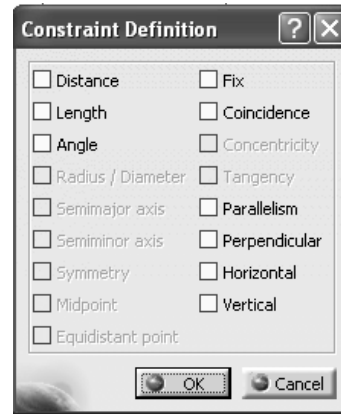

- 8) Apply a parallel constraint between the left and right lines of the profile in a similar way.

- 9) Apply **Constraints**  to the rectangle and change their values to the values shown in the figure.

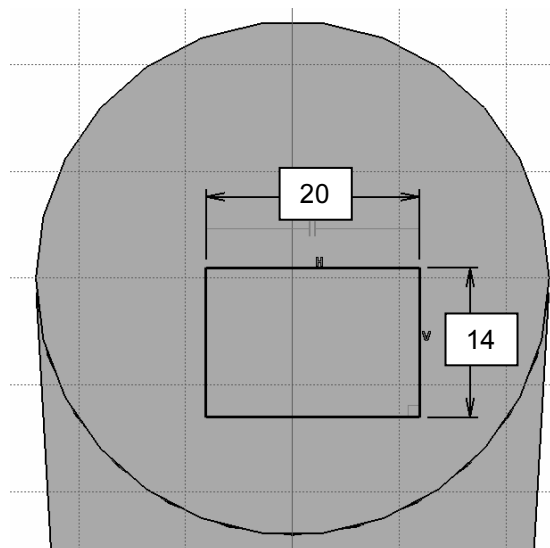

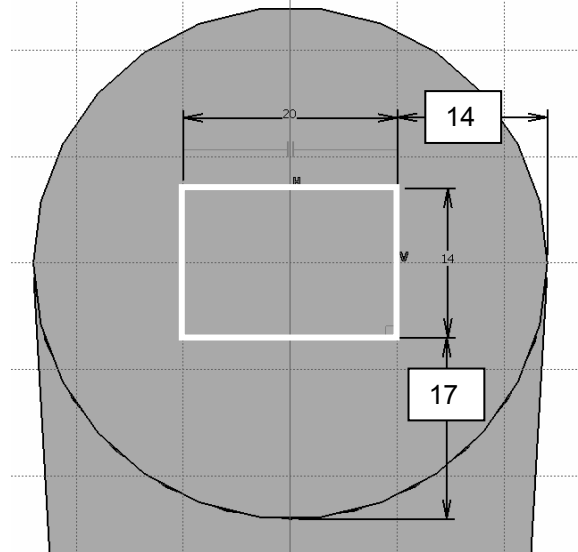

10) Apply the additional dimensional constraints shown in order to position the rectangle. Select the

**Constraints**  icon, then the circumference of the circle and then the appropriate side of the rectangle. Notice that once all the constraints are applied, the rectangle turns green indicating that it is fully constrained.



11) Draw the triangle shown using the

**Profile**  command. When drawing the triangle make sure that the top point is aligned with the origin (  ) and the bottom line is horizontal (H).

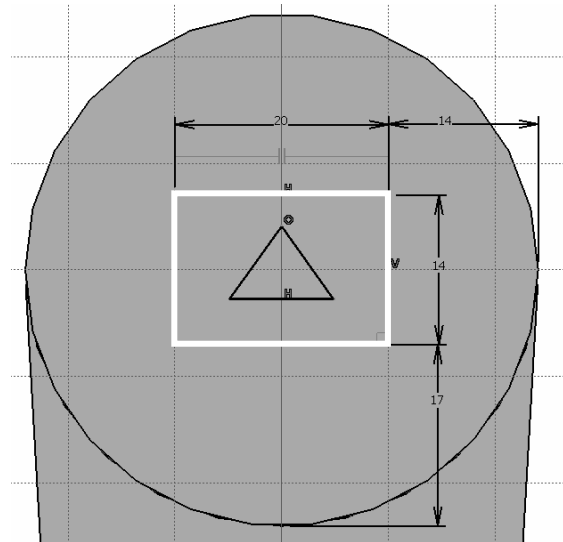

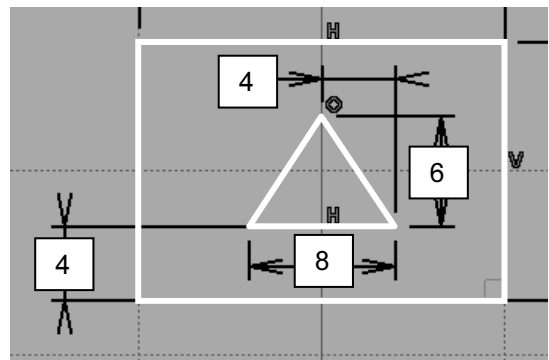

12) Constrain the vertical height of the triangle to be **6 mm**. Select the

**Constraints**  icon, select the one of the angled lines of the triangle, right click and select **Vertical Measure Direction**.



13) **Constrain**  the rest of the triangle as shown.

14) Exit the Sketcher  and Pad  the sketch to a length of **5 mm**.

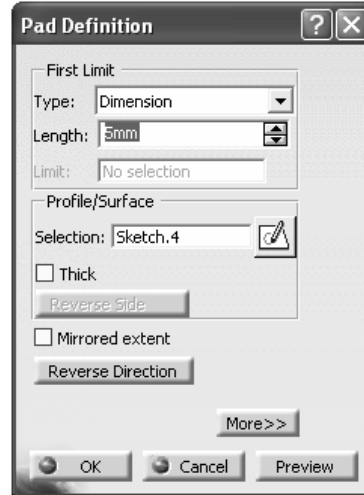
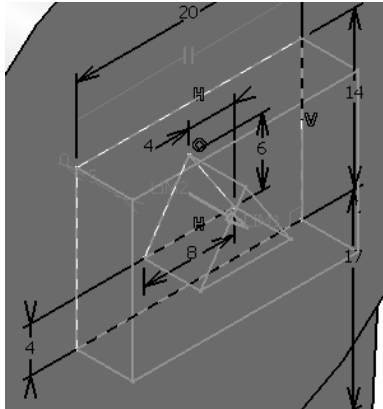

**Section 5: Creating arcs.**

1) Enter the **Sketcher**  on the front face of the middle section.

2) Activate the **Construction/Standard Element**  icon.

3) Select the **Project 3D Elements**  icon and then project the front face of the middle section.

4) Deactivate the **Construction/Standard Element**  icon.

5) Activate your **Snap to Point**  icon.

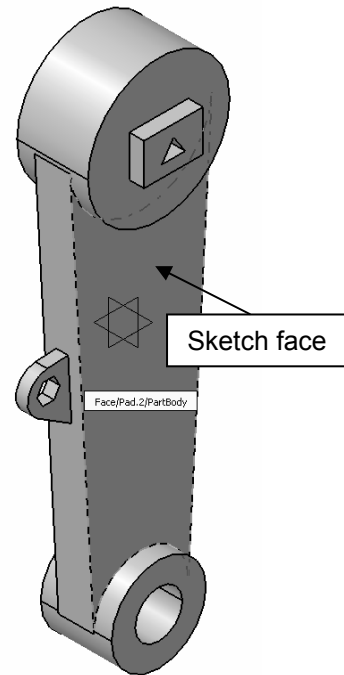
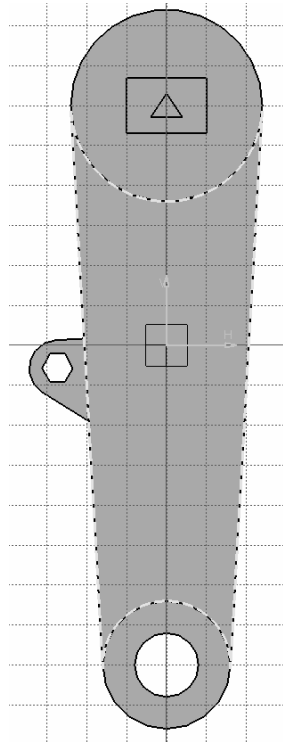

6) Draw the profile shown. Use the **Three Point Arc**

command to create the bottom arc, the **Arc** command to create the top arc. The *Arc* icons are stacked under the *Circle* icon. For assistance in creating the arcs, read the prompt line at the bottom of the graphics screen. Use the **Profile**

command to create the connecting lines.

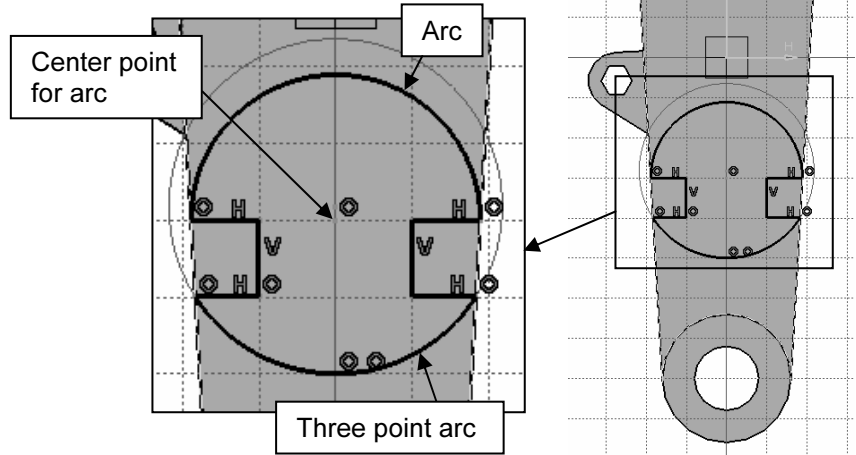

7) **Exit** the Sketcher and **Pad** the sketch to a length of **30 mm**.

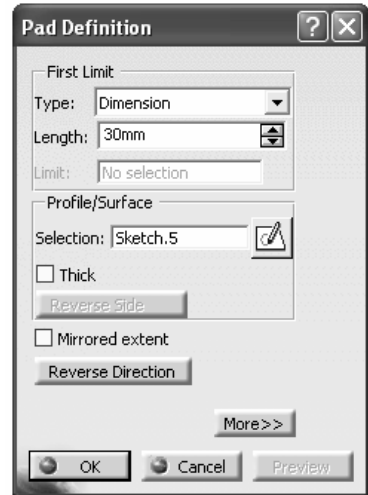
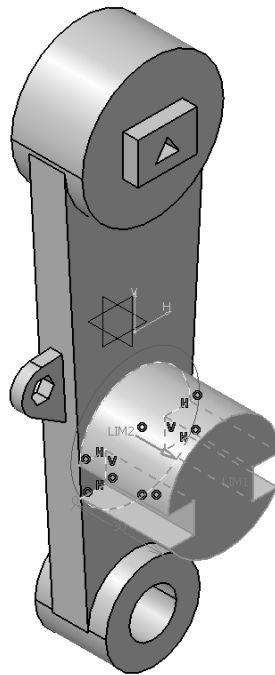

8) Deselect all.

9) Mirror the entire solid. Select the **Mirror**  icon. In the Mirror Definition window fill in the following fields; Mirroring element: Select the face indicated in the figure, Object to mirror: Current Solid.

