

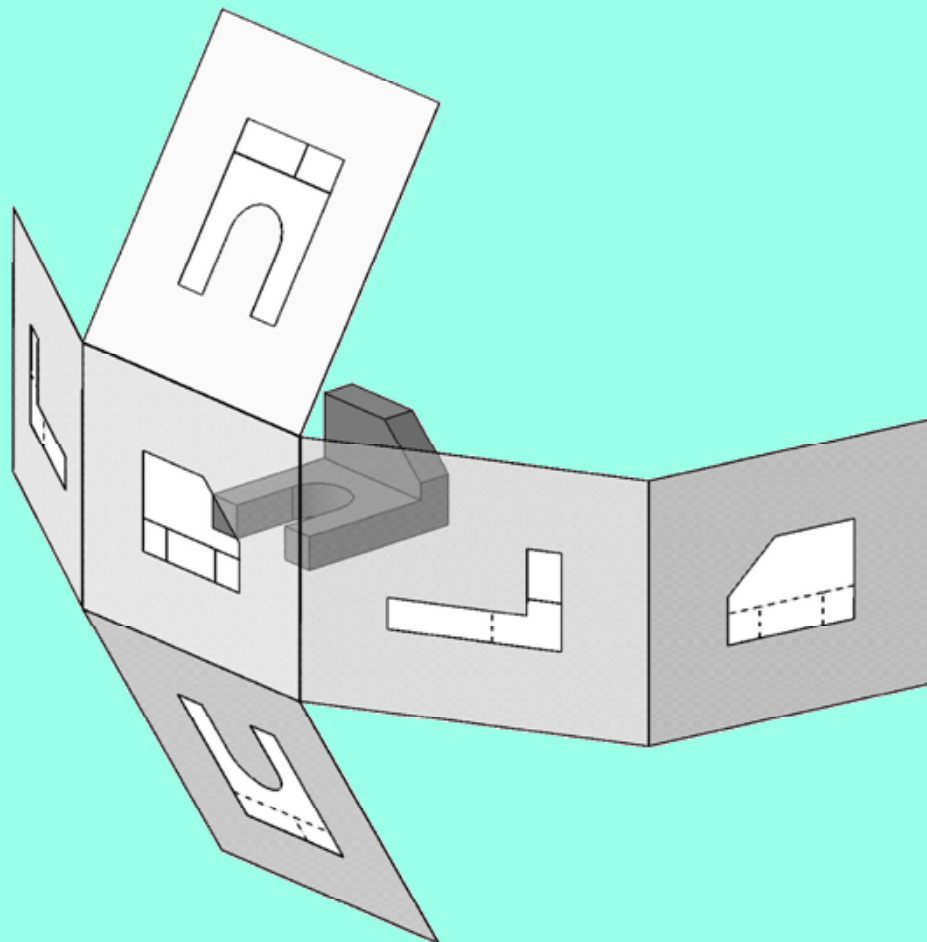

# ENGINEERING GRAPHICS ESSENTIALS

with AutoCAD® 2007 Instruction



Kirstie Plantenberg  
University of Detroit Mercy



**SDC**

PUBLICATIONS

Schroff Development Corporation

---

[www.schroff.com](http://www.schroff.com)  
[www.schroff-europe.com](http://www.schroff-europe.com)

# ORTHOGRAPHIC PROJECTION

*In Chapter 2 you will learn the importance of engineering graphics and how to create an orthographic projection. An orthographic projection describes the shape of an object. It is a two dimensional representation of a three dimensional object. Different line types are used to indicate visible, hidden and symmetry lines. By the end of this chapter, you will be able to create a technically correct orthographic projection using proper projection techniques.*

---

## **2.1) INTRODUCTION TO ENGINEERING GRAPHICS**

*What is Engineering Graphics?* Engineering graphics is a set of rules and guidelines that help you create an engineering drawing. *What is an Engineering Drawing?* An engineering drawing is a drawing or a set of drawings that communicates an idea, design, schematic, or model. Engineering drawings come in many forms. Each engineering field has its own type of engineering drawings. For example, electrical engineers draw circuit schematics and circuit board layouts. Civil engineers draw plans for bridges and road layouts. Mechanical engineers draw parts and assemblies that need to be manufactured. This book focuses on the latter. This is not to say that only students in a mechanical engineering curriculum will benefit from learning engineering graphics. It benefits everyone from the weekend carpenter who wants to draw plans for his/her new bookshelf to the electrical engineer who wants to analyze electrical component cooling using a CAE program. Engineering graphics teaches you how to visualize and see all sides of an object in your mind. Being able to visualize in your mind will help you in several aspects of critical thinking.

## **2.2) ORTHOGRAPHIC PROJECTION INTRODUCTION**

***An orthographic projection enables us to represent a 3-D object in 2-D*** (see Figure 2-1). An orthographic projection is a system of drawings that represent different sides of an object. These drawings are formed by projecting the edges of the object perpendicular to the desired planes of projection. Orthographic projections allow us to represent the shape of an object using 2 or more views. These views together with dimensions and notes are sufficient to manufacture the part.

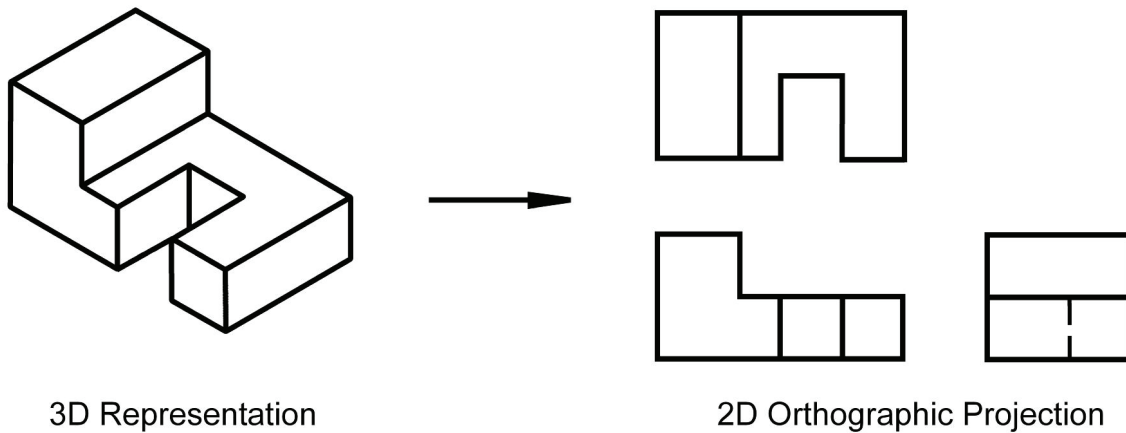

Figure 2-1: Orthographic projection.

---

### 2.2.1) The Six Principle Views

The 6 principle views of an orthographic projection are shown in Figure 2-2. Each principle view is created by looking at the object in the directions indicated in Figure 2-2 and drawing what is seen as well as what is hidden from view.

---

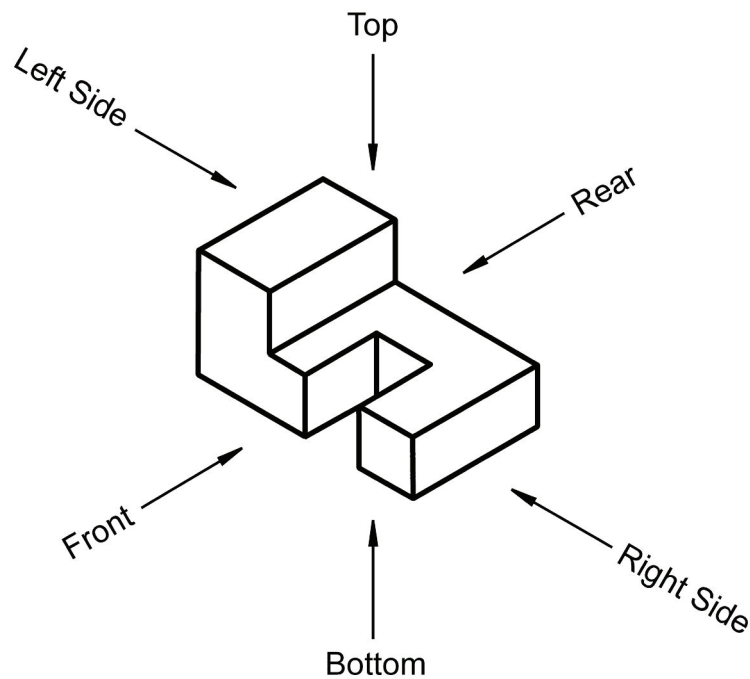

Figure 2-2: The six principle views.

---

### 2.3) THE GLASS BOX METHOD

To obtain an orthographic projection, an object is placed in an imaginary glass box as shown in Figure 2-3. The sides of the glass box represent the six principle planes. Images of the object are projected onto the sides of the box to create the six principle views. The box is then unfolded to lie flat, showing all views in a 2-D plane. Figure 2-4 shows the glass box being unfolded to create the orthographic projection of the object.

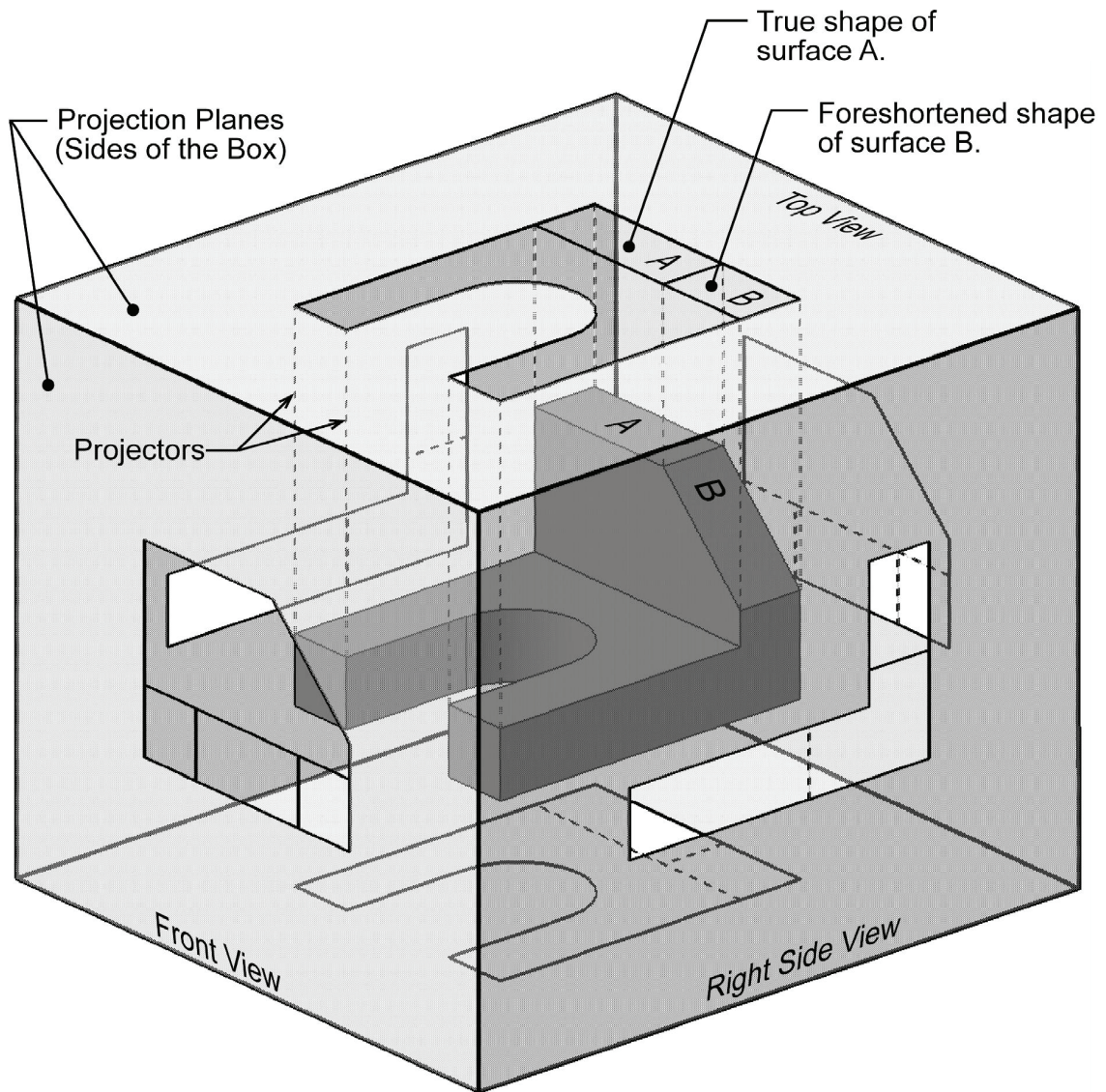

Figure 2-3: Object in a glass box.



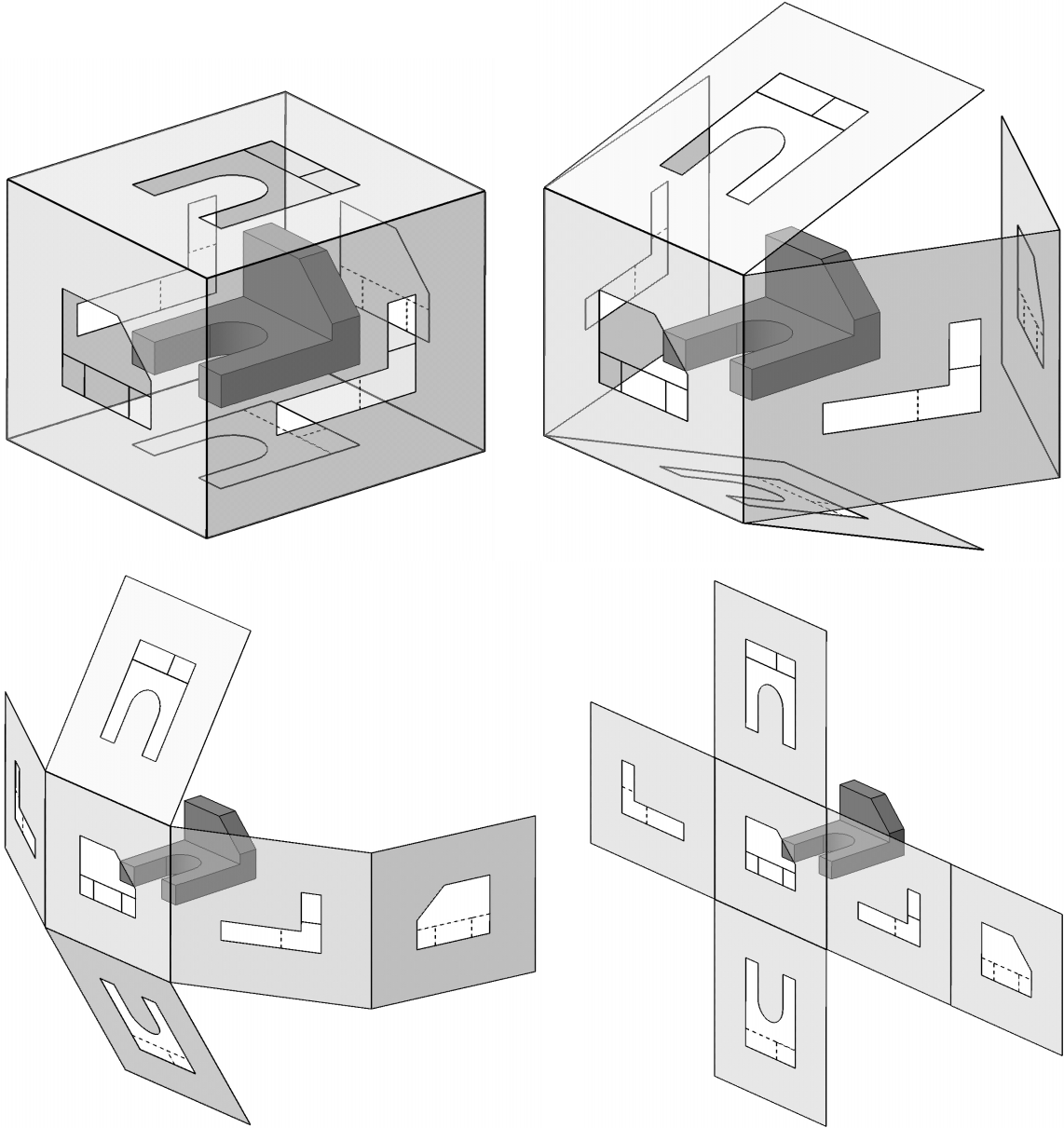
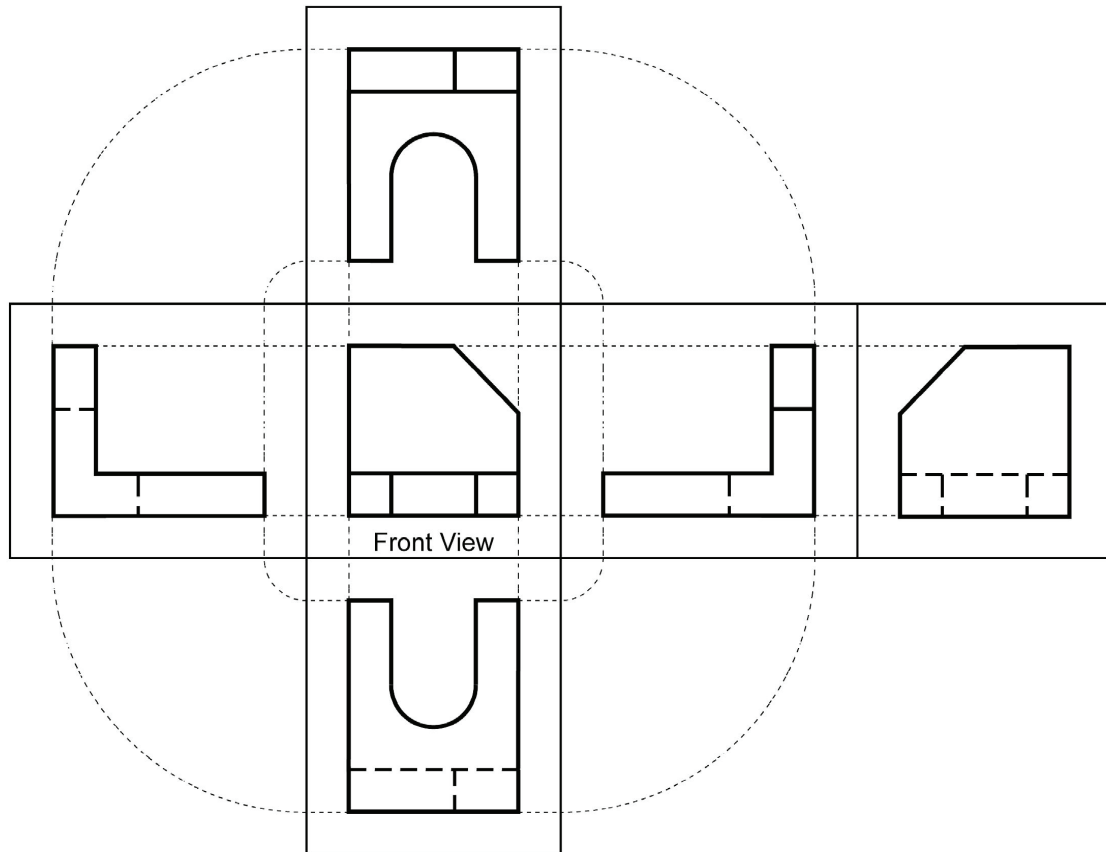

Figure 2-4: Glass box being unfolded.

### Instructor Led Exercise 2-1: Principle views

Label the five remaining principle views with the appropriate view name.



What are the differences between the *Right Side* and *Left Side* views?

What are the differences between the *Top* and *Bottom*, and *Front* and *Rear* views?

Which view(s) have the least number of hidden or dashed lines?

## 2.4) THE STANDARD VIEWS

When constructing an orthographic projection, we need to include enough views to completely describe the true shape of the part. The more complex a part, the more views are needed to describe it completely. Most objects require three views to completely describe them. **The standard views used in an orthographic projection are the *front, top, and right side views*.** The other views (bottom, rear, left side) are omitted since they usually do not add any new information. It is not always necessary to use the three standard views. Some objects can be completely described in one or two views. For example, a sphere only requires one view, and a block only requires two views.

### 2.4.1) The Front View

**The *front view* shows the most features or characteristics of the object.** It usually contains the least number of hidden lines. The exception to this rule is when the object has a predefined or generally accepted front view. All other views are based on the orientation chosen for the front view. The top, front, and bottom views are all aligned vertically and share the same width dimension. The left side, front, right side, and rear views are all aligned horizontally and share the same height dimension (see the figure shown in Exercise 2-1).

## 2.5) LINE TYPES USED IN AN ORTHOGRAPHIC PROJECTION

***Line type and line weight provide valuable information to the print reader.*** For example, the type and weight of a line can answer the following questions: Is the feature visible or hidden from view? Is the line part of the object or part of a dimension? Is the line indicating symmetry? There are four commonly used line types: continuous, hidden, center and phantom. The standard recommends using, no less than, two line widths. Important lines should be twice as thick and as the less important thin lines. Common thicknesses are 0.6 mm for important lines and 0.3 mm for the less important lines. However, to further distinguish line importance, it is recommended to use four different thicknesses or weights: thin, medium, thick, and very thick. The actual line thickness should be chosen such that there is a visible difference between the line weights; however, they should not be too thick or thin making it difficult to read the print. The thickness of the lines should be adjusted according to the size and complexity of the part. The following is a list of common line types and widths used in an orthographic projection.

1. Visible lines: Visible lines represent visible edges and boundaries. The line type is **continuous** and the line weight is **thick** (0.5 - 0.6 mm).
2. Hidden lines: Hidden lines represent edges and boundaries that cannot be seen. The line type is **dashed** and the line weight is **medium thick** (0.35 - 0.45 mm).

3. Center lines: Center lines represent axes of symmetry and are important for interpreting cylindrical shapes. Crossed center lines should be drawn at the centers of circles. They are also used to indicate circle of centers and paths of motion. The line type is **long dash – short dash** and the line weight is **thin** (0.3 mm).
4. Phantom lines: Phantom lines are used to indicate imaginary features. For example, they are used to indicate the alternate positions of moving parts, and adjacent positions of related parts. The line type is **long dash – short dash – short dash** and the line weight is usually **thin** (0.3 mm).
5. Dimension and Extension lines: Dimension and extension lines are used to show the size of an object. In general, a dimension line is placed between two extension lines and is terminated by arrowheads, which indicates the direction and extent of the dimension. The line type is **continuous** and the line weight is **thin** (0.3 mm).
6. Cutting plane lines: Cutting plane lines are used to show where an imaginary cut has been made through the object in order to view interior features. The line type is **phantom** and the line weight is **very thick** (0.6 to 0.8 mm). Arrows are placed at both ends of the cutting plane line to indicate the direction of sight.
7. Section lines: Section lines are used to show areas that have been cut by the cutting plane. Section lines are grouped in parallel line patterns and usually drawn at a 45° angle. The line type is usually **continuous** and the line weight is **thin** (0.3 mm).
8. Break lines: Break lines are used to show imaginary breaks in objects. A break line is usually made up of a series of connecting arcs. The line type is **continuous** and the line weight is usually **thick** (0.5 – 0.6 mm).

**Instructor Led Exercise 2-2: Line types**

Using the line type definitions given on the previous page, draw each line type listed.

- Visible Line
- Hidden Line
- Center Line
- Phantom Line
- Dimension and Extension Lines
- Cutting Plane Line
- Section Lines
- Break Line



**Instructor Led Exercise 2-3: Line use in an orthographic projection**

Fill the following dotted orthographic projection with the appropriate line types.

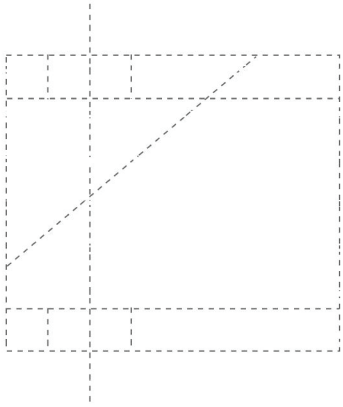
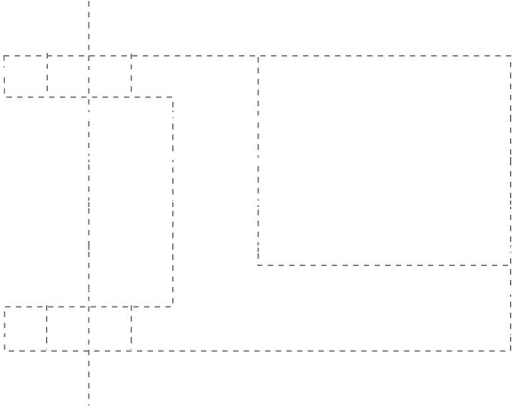
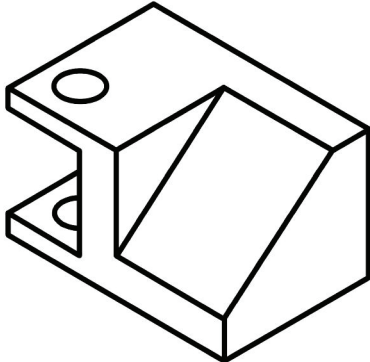
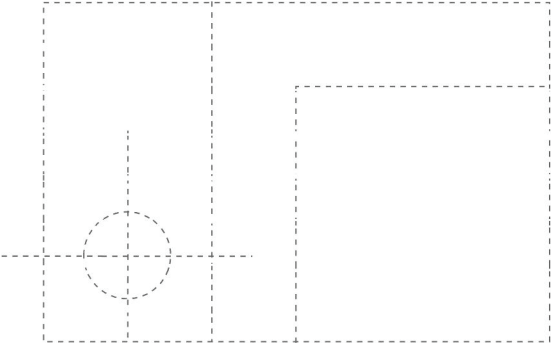

## 2.6) RULES FOR LINE CREATION AND USE

The rules and guide lines for line creation should be followed in order to create lines that are effective in communicating the drawing information. However, due to computer automation, some of the rules may be hard to follow.

### 2.6.1) Hidden Lines

Hidden lines represent edges and boundaries that cannot be seen.

Rule 1. The length of the hidden line dashes may vary slightly as the size of the drawing changes. For example, a very small part may require smaller dashes in order for the hidden line to be recognized.

Rule 2. Hidden lines should always begin and end with a dash, except when the hidden line begins or ends at a parallel visible or hidden line (see Figure 2-5).

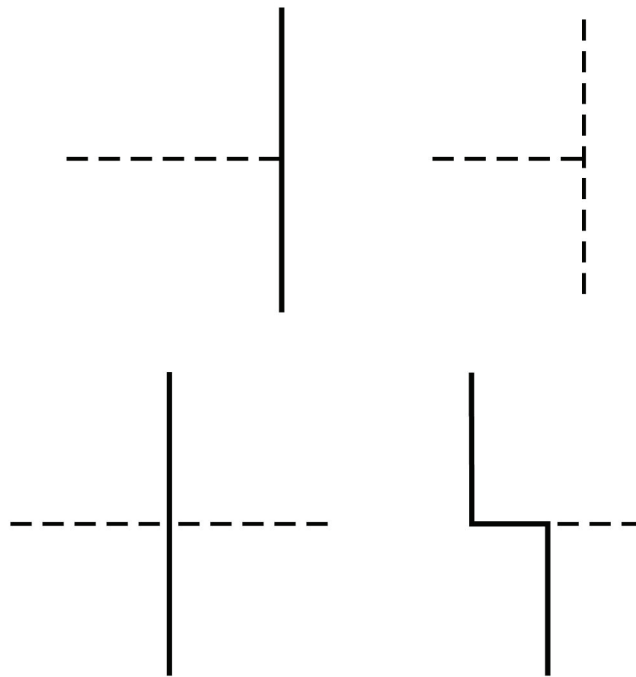

---

Figure 2-5: Drawing hidden lines.

---

---

Rule 3. Dashes should join at corners (see Figure 2-6).

---

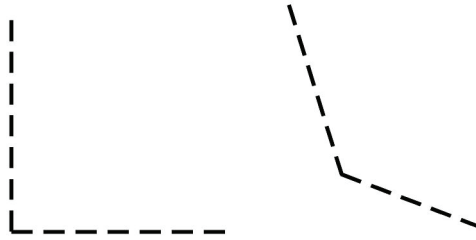

---

Figure 2-6: Hidden lines at corner.

---

### 2.6.2) Center Lines

Center lines represent axes of symmetry and are important for interpreting cylindrical shapes. They are also used to indicate circle of centers, as shown in Figure 2-7, and paths of motion.

---

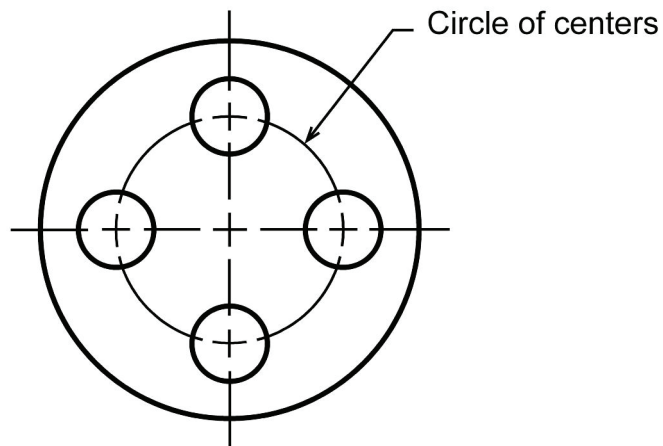

---

Figure 2-7: Circle of centers.

---

Rule 1. Center lines should start and end with long dashes (see Figure 2-8).

Rule 2. Center lines should intersect by crossing either the long dashes or the short dashes (see Figure 2-8).

---

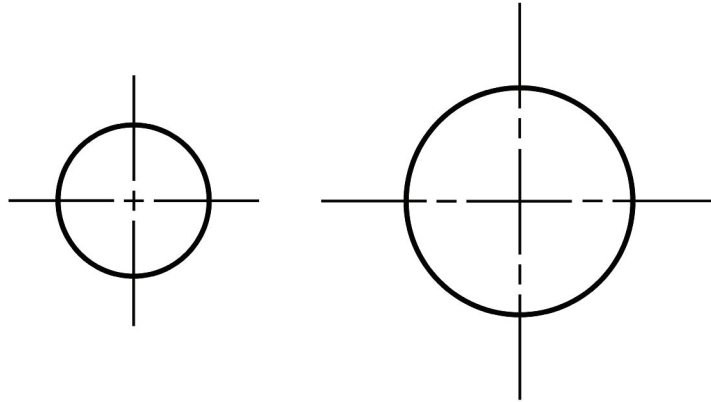

---

Figure 2-8: Crossing center lines.

---

Rule 3. Center lines should extend a short distance beyond the object or feature. They should not terminate at other lines of the drawing (see Figure 2-9).

---

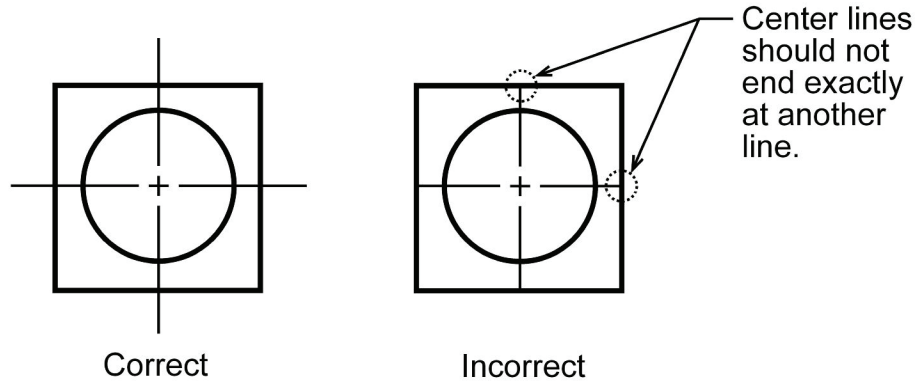

---

Figure 2-9: Terminating center lines.

---

Rule 4. Center lines may be connected within a single view to show that two or more features lie in the same plane as shown in Figure 2-10. However, they should not extend through the space between views.

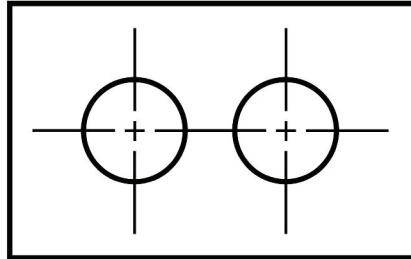

Figure 2-10: Connecting center lines.

### 2.6.3) Phantom Lines

Phantom lines should start and end with a long dash. Phantom lines are used to indicate alternate positions of moving parts. They may also be used to indicate adjacent positions of related parts and repeated detail. They are also used to show fillets and rounds in the view that does not show the radius. In this case, the phantom lines are used to show a change in surface direction. Examples of phantom line use are shown in Figures 2-11 and 2-12.

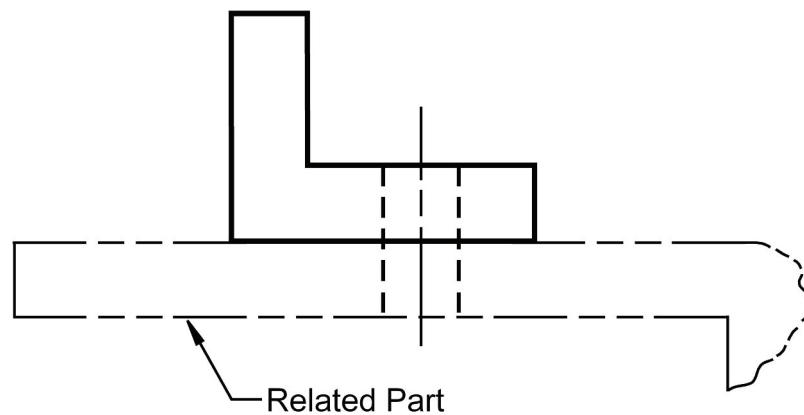

Figure 2-11: Related part.





---

Figure 2-12: Repeated detail.

---

#### 2.6.4) Break Lines

Break lines are used to show imaginary breaks in an object. For example, when drawing a long rod, it may be broken and drawn at a shorter length as shown in Figure 2-13.

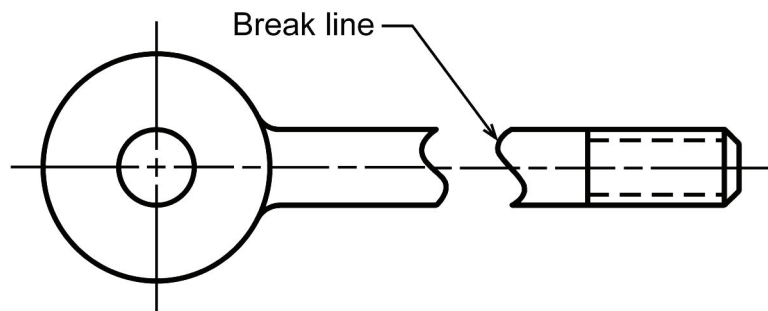

---

Figure 2-13: Using break lines.

---

There are two types of break lines. A break line may be a series of connecting arcs, as shown in Figure 2-13, or a straight line with a jog in the middle as shown in Figure 2-14. If the distance to traverse is short the series of connecting arcs is used. This series of arcs is the same width as the visible lines on the drawing. If the distance is long the thin straight line with a jog is used.

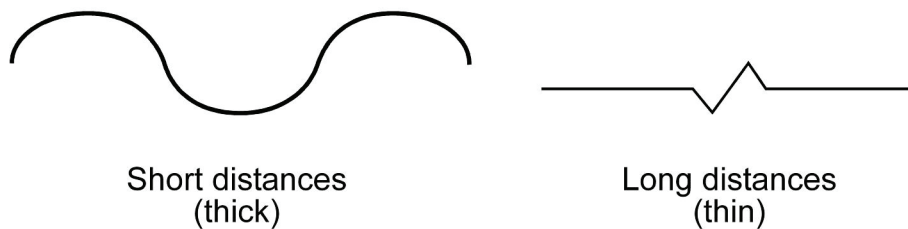

---

Figure 2-14: Types of break lines.

---

### 2.6.5) Line Type Precedence

Some lines are considered more important than other lines. **If two lines occur in the same place, the line that is considered to be the least important is omitted.** Lines in order of precedence/importance are as follows:

1. Cutting plane line
2. Visible line
3. Hidden line
4. Center line

### 2.7) CREATING AN ORTHOGRAPHIC PROJECTION

The steps presented in this section are meant to help you create a technically correct orthographic projection using the 3<sup>rd</sup> angle projection standard. To understand and visually see how views are created using the 3<sup>rd</sup> angle projection standard, put your right hand on a table palm up. You are looking at the front view of your hand. Now rotate your hand so that your thumb points up and your little finger is touching the table. This is the right side view of your hand. Put your hand back in the front view position. Now rotate your hand so that your finger tips are pointing up and your wrist is touching the table. This is the top view of your hand.

The following steps will take you through the creation of an orthographic projection. Once you become experienced and proficient at creating orthographic projections, you will develop short cuts and may not need to follow the steps exactly as written. These steps are visually illustrated in Figure 2-15.

1. **Choose a front view.** This is the view that shows the most about the object.
2. **Decide how many views are needed** to completely describe the object. If you are unable to determine which views will be needed, draw the standard views (front, top and right side).
3. **Draw the visible features of the front view.**
4. **Draw projectors off of the front view** horizontally and vertically in order to create the boundaries for the top and right side views.
5. **Draw the top view.** Use the vertical projectors to fill in the visible and hidden features.
6. **Project from the top view back to the front view.** Use the vertical projectors to fill in any missing visible or hidden features in the front view.
7. **Draw a 45° projector** off of the upper right corner of the box that encloses the front view.
8. **From the top view, draw projectors over to the 45° line and down** in order to create the boundaries of the right side view.
9. **Draw the right side view.**
10. **Project back to the top and front view** from the right side view as needed.
11. **Draw center lines where necessary.**

Following the aforementioned steps will insure that the orthographic projection is done correctly. That is, it will insure that:

- ✓ The front and top views are vertically aligned.
- ✓ The front and right side views are horizontally aligned.
- ✓ Every point or feature in one view is aligned on a projector in any adjacent view (front and top, or front and right side).
- ✓ The distance between any two points of the same feature in the related views (top and right side) are equal.

Figure 2-15 identifies the *adjacent* and *related* views. Adjacent views are two adjoining views aligned by projectors. Related views are views that are adjacent to the same view.

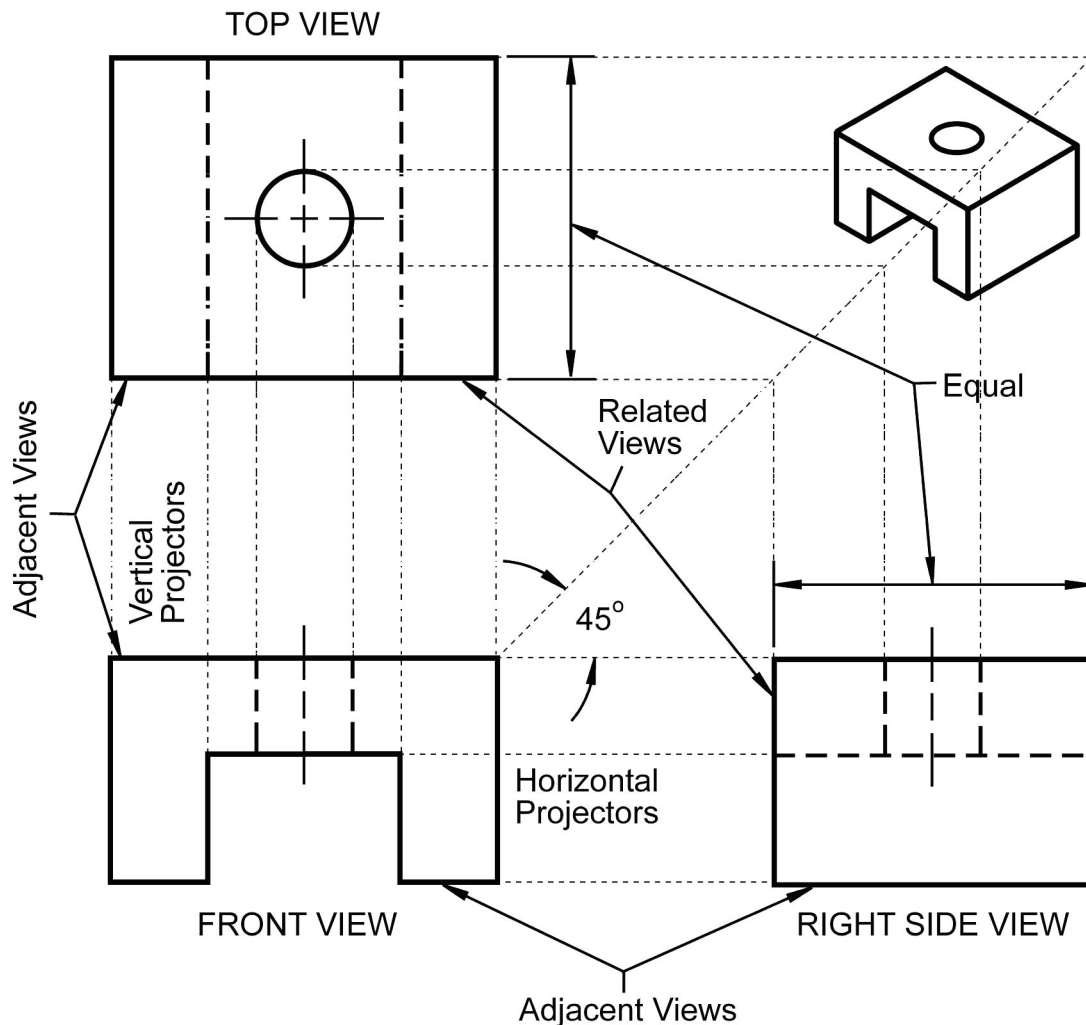

Figure 2-15: Creating an orthographic projection

### 2.7.1) Projection Symbol

In the United States, we use 3<sup>rd</sup> angle projection to create an orthographic projection. This is the method of creating orthographic projections that is described in this chapter. In some parts of Europe and elsewhere 1<sup>st</sup> angle projection is used. To inform the print reader what projection method was used, the projection symbol should be placed in the bottom right hand corner of the drawing. If the drawing uses metric units, the text “SI” is placed in front of the projection symbol. The projection symbols are shown in Figure 2-16. Figure 2-17 shows the projection symbol’s proportions.

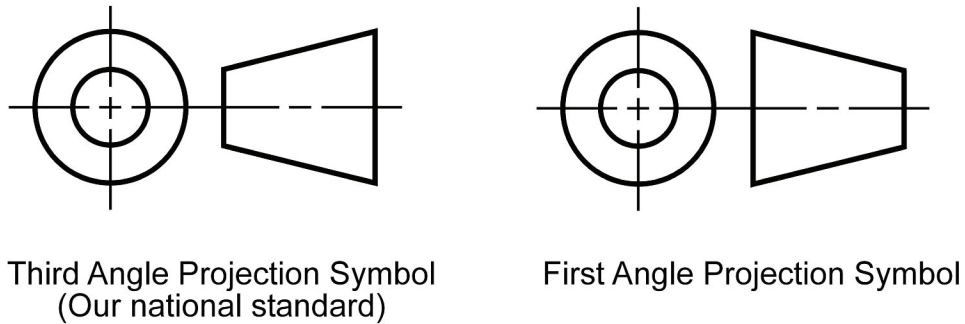

Figure 2-16: First and third angle projection symbols.

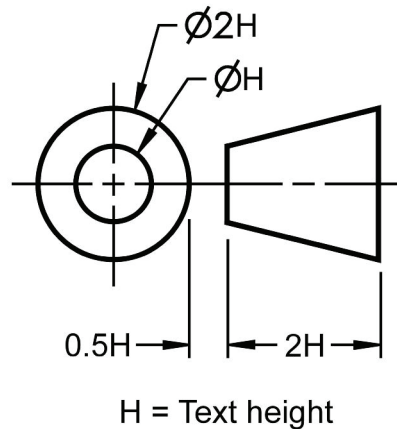

Figure 2-17: Projection symbol proportions.

NOTES:



**In Class Student Exercise 2-4: Missing lines 1**

Name: \_\_\_\_\_ Date: \_\_\_\_\_

Fill in the missing lines in the front, right side, and top views. **Hint:** The front view has one missing visible line. The right side view has one missing visible line and two missing hidden lines. The top view has five missing visible lines and two missing hidden lines.

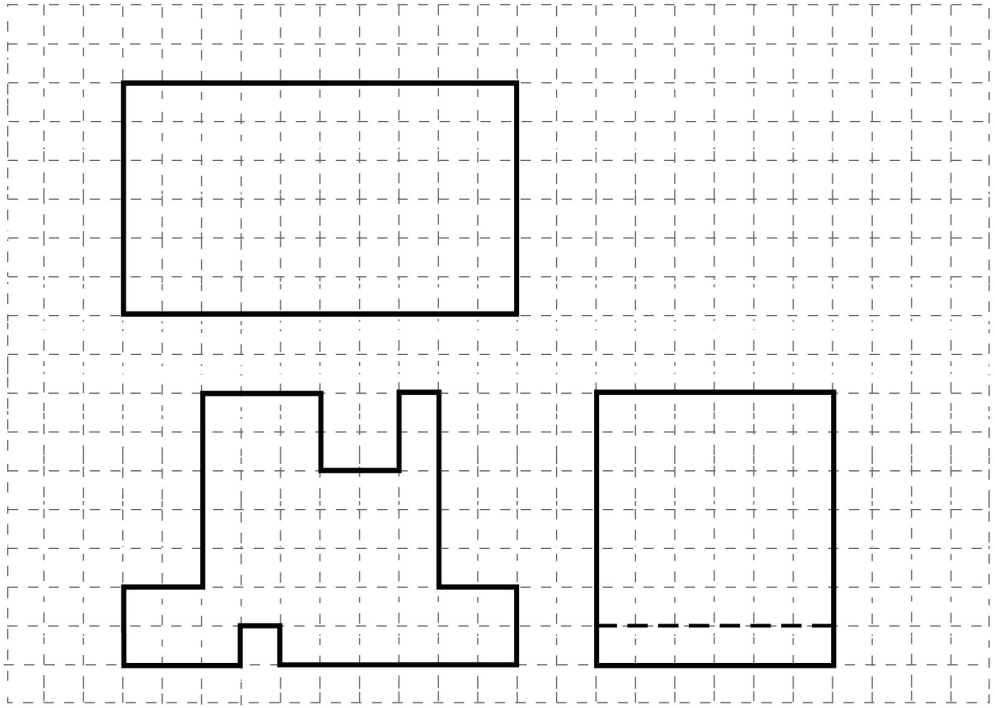
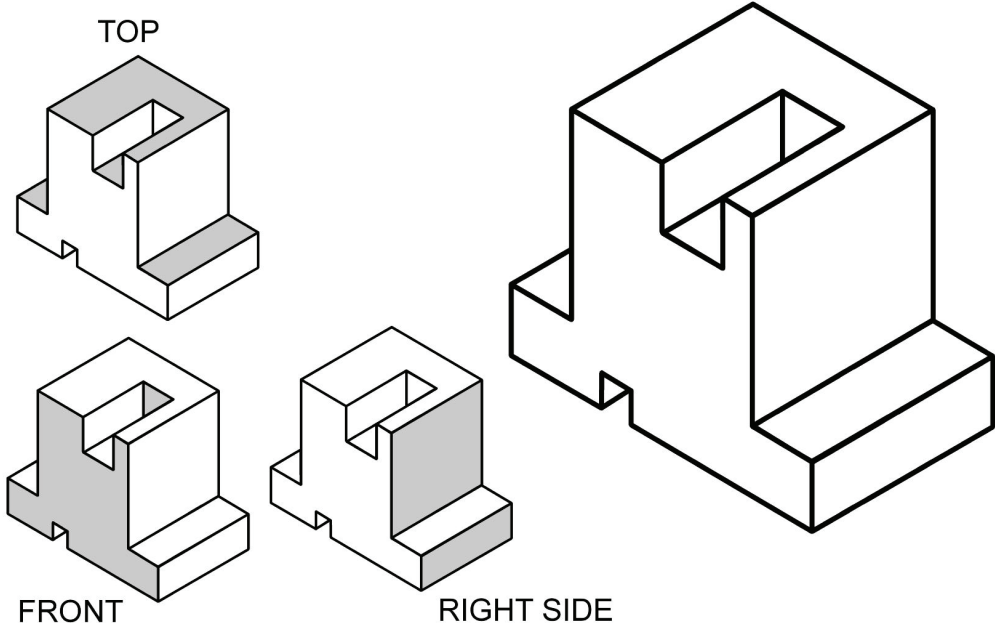

NOTES:

**In Class Student Exercise 2-5: Missing lines 2**

Name: \_\_\_\_\_ Date: \_\_\_\_\_

Fill in the missing lines in the top, front, and right side views. **Hint:** The top view has one missing visible line. The front view has four missing visible lines and four missing center lines. The right side view has two missing hidden lines and one missing center line.

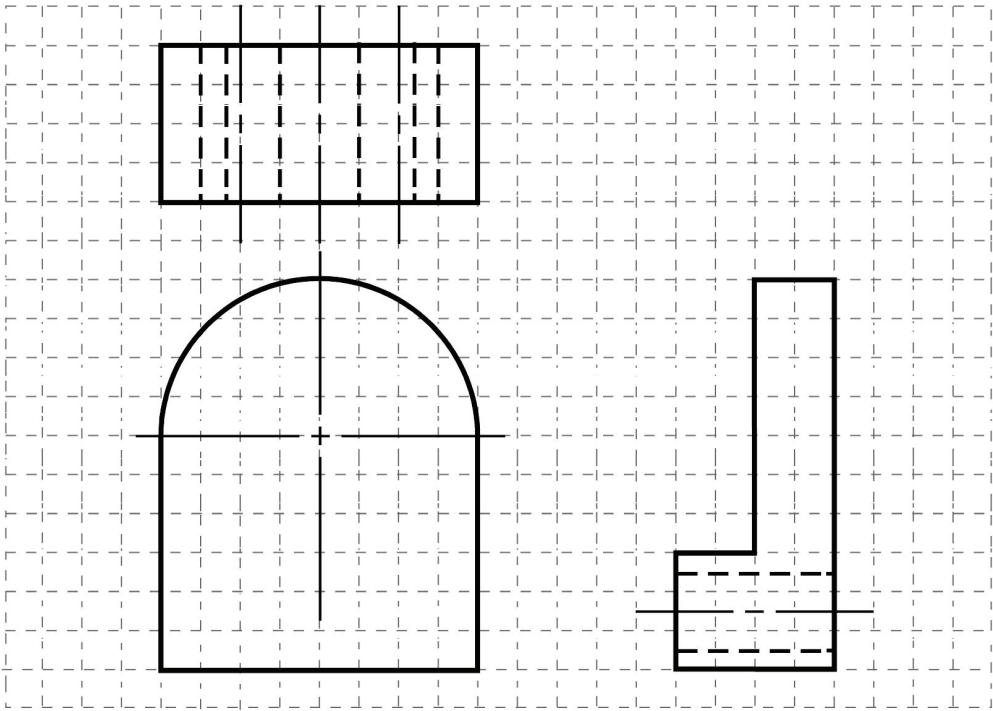
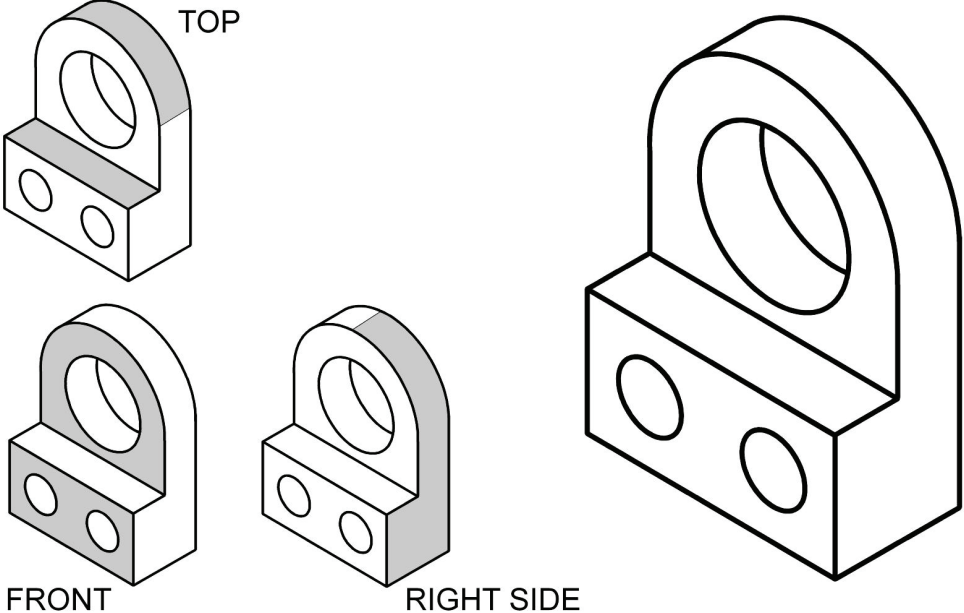

NOTES:

**In Class Student Exercise 2-6: Drawing a orthographic projection 1**

Name: \_\_\_\_\_ Date: \_\_\_\_\_

Shade in the surfaces that will appear in the front, top, and right side views. Estimating the distances, draw the front, top, and right side views. Identify the surfaces with the appropriate letter in the orthographic projection.

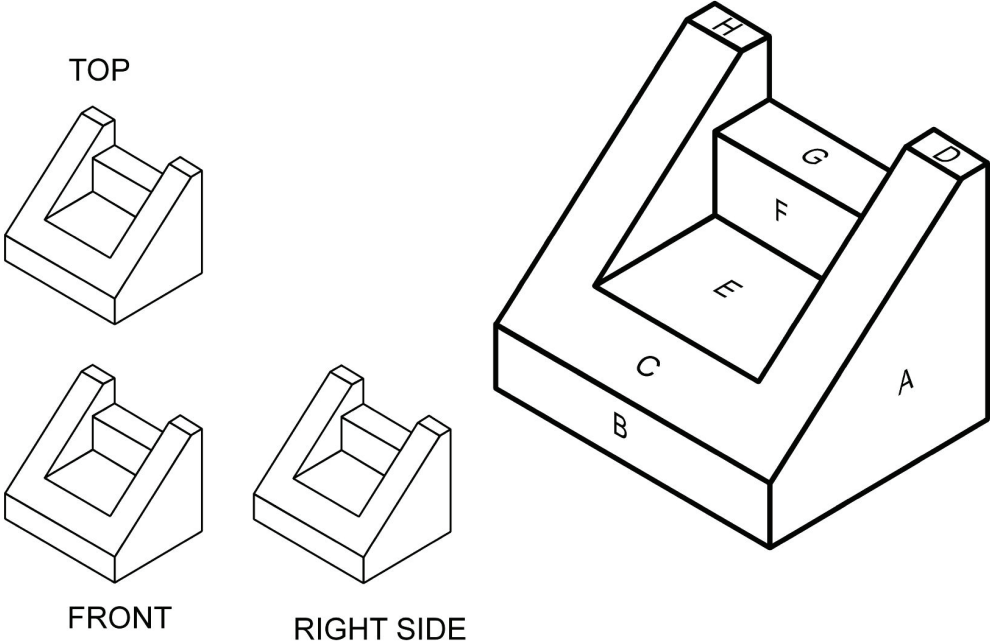

TOP

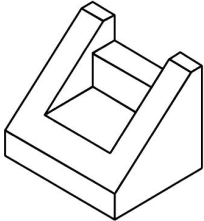
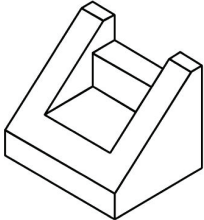

FRONT

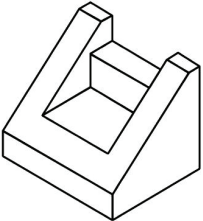

RIGHT SIDE

A large grid of dashed lines for drawing the orthographic projections.



NOTES:

**In Class Student Exercise 2-7: Drawing orthographic projection 2**

Name: \_\_\_\_\_ Date: \_\_\_\_\_

Identify the best choice for the front view. Estimating the distances, draw the front, top, and right side views.

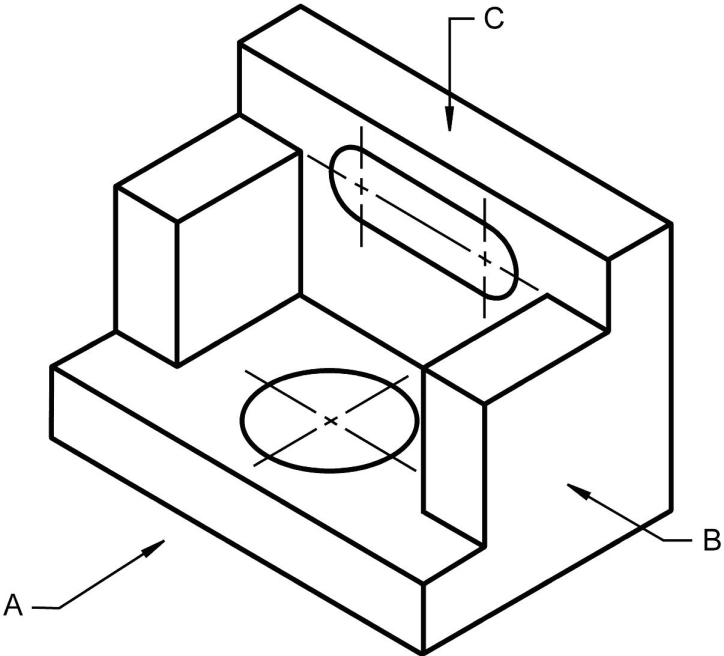

A large grid of dashed lines for drawing the orthographic projections.

**2.8) AUXILIARY VIEWS**

Auxiliary views are used to show the true shape of features that are not parallel to any of the principle planes of projection. Auxiliary views are aligned with the angled features from which they are projected. Partial auxiliary views are often used to shown only a particular feature that is not described by true projection in the principle views. Figure 2-18 shows the use of auxiliary views.

---

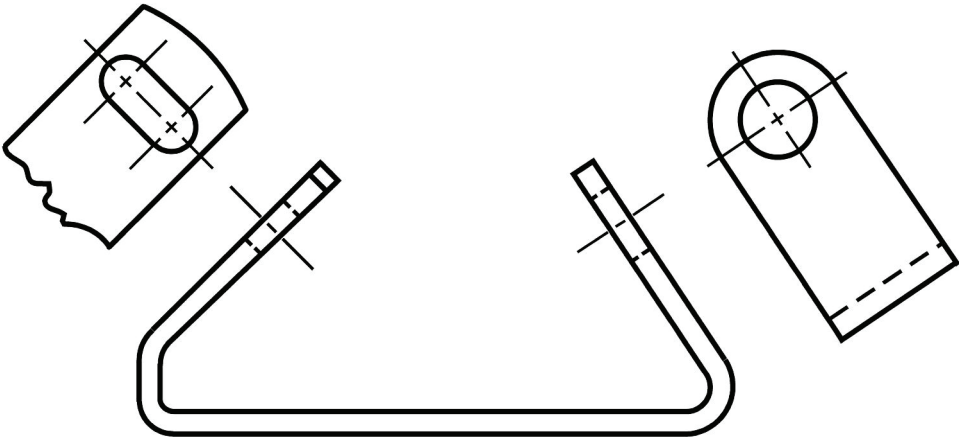

---

Figure 2-18: Auxiliary views.

---

**In Class Student Exercise 2-8: Auxiliary view**

Name: \_\_\_\_\_ Date: \_\_\_\_\_

Draw the auxiliary view for this object.

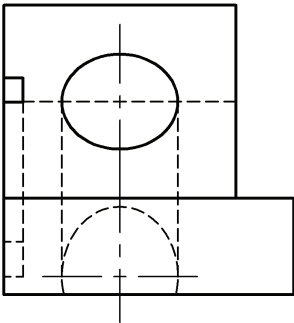
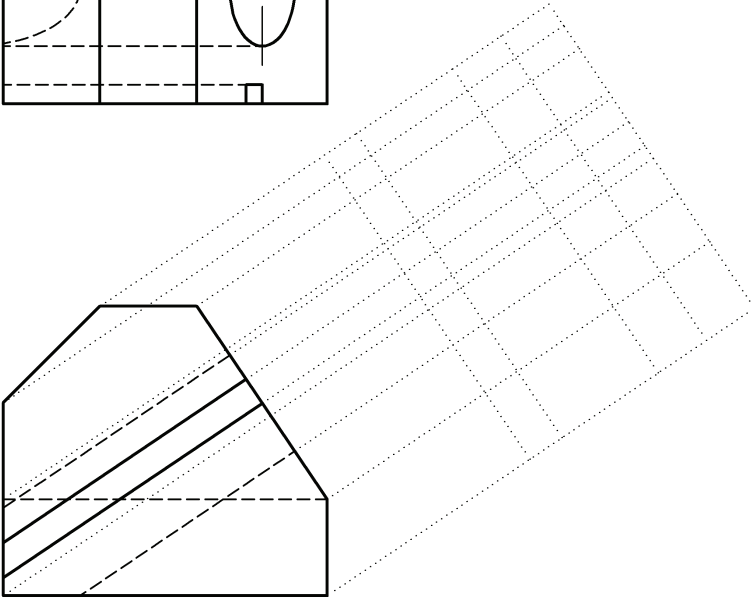
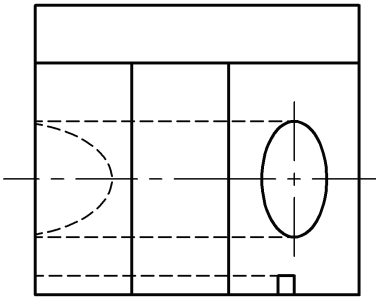
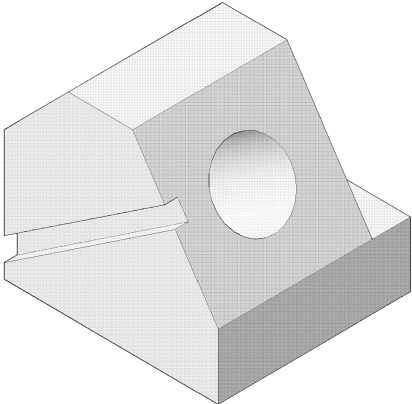

NOTES:

**ORTHOGRAPHIC PROJECTION REVIEW QUESTIONS**

Name: \_\_\_\_\_ Date: \_\_\_\_\_

Answer the following questions.

**Q2-1)** Is an orthographic projection a 2-D or 3-D representation of an object?

**Q2-2)** Center lines should end at the boundary of an object. (True, False)

**Q2-3)** List two situations where a phantom line would be used?

**Q2-4)** What is the thickest line type on a non-sectioned orthographic projection?

**Q2-5)** What are the standard views used in an orthographic projection?

**Q2-6)** Are the top and front views aligned vertically or horizontally?

**Q2-7)** Are the front and right side views aligned vertically or horizontally?

**Q2-8)** Are projection or construction lines usually shown on a drawing?

**Q2-9)** Which view generally contains the least number of hidden lines?

**Q2-10)** Why do we use different line types and line weights?

**Q2-11)** What line type is used to indicate symmetry?

**Q2-12)** Rank the following line types in order of precedence, 1 being the most important.

- a. Center line
- b. Visible
- c. Hidden

**Q2-13)** The United States uses (1<sup>st</sup> , 3<sup>rd</sup> ) angle projection.

**Q2-14)** In what situation would an auxiliary view be used?

**Q2-15)** In what situation would a detail view be used?

**ORTHOGRAPHIC PROJECTION PROBLEMS**

Name: \_\_\_\_\_ Date: \_\_\_\_\_

**P2-1)** 3-D pictorials of two objects are shown with labeled surfaces. Identify those surfaces on the corresponding 2-D orthographic projections. Dashed circles and leaders point to hidden surfaces and edges.

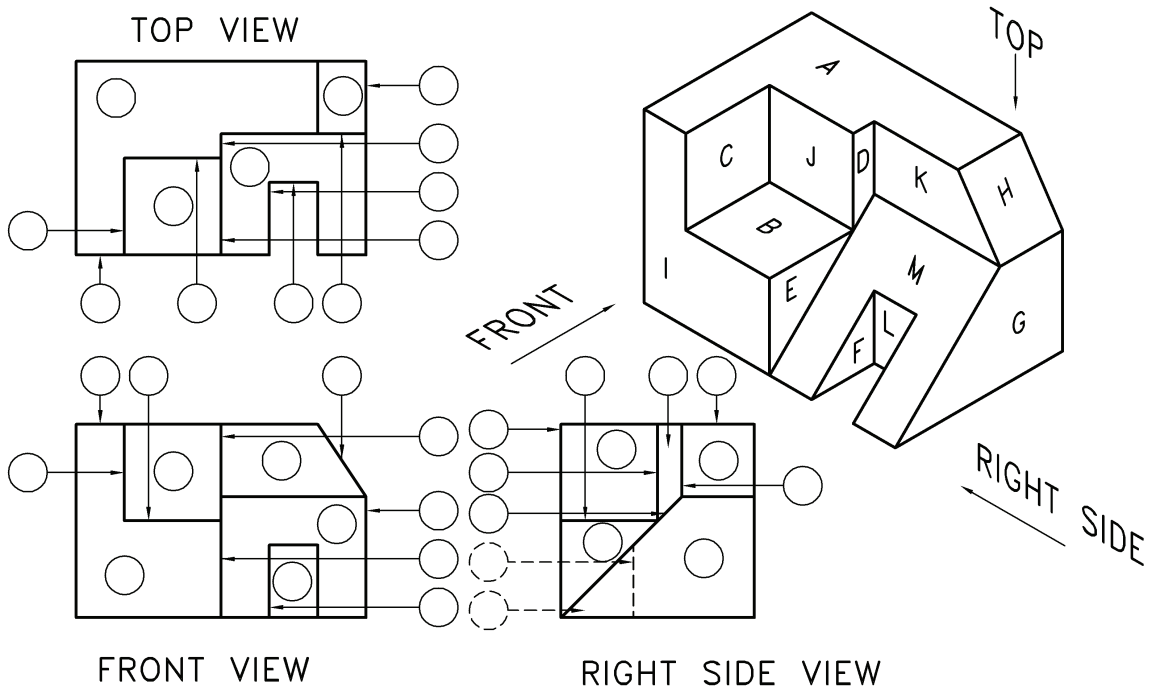
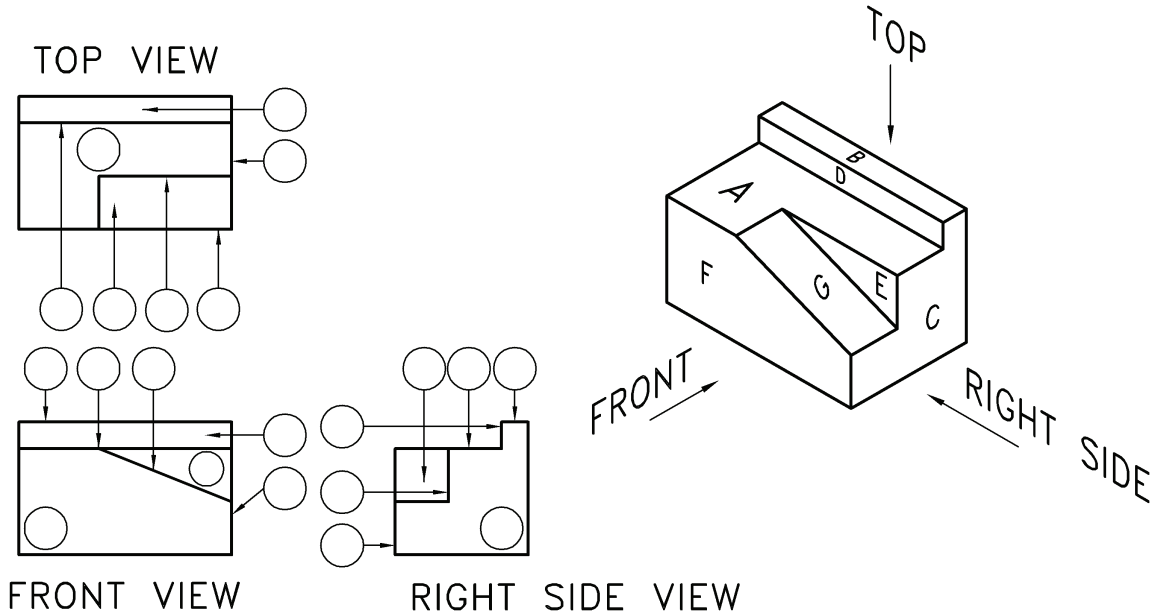



NOTES:

Name: \_\_\_\_\_ Date: \_\_\_\_\_

**P2-2)** Sketch the front, top and right side views of the following object. Use the grid provided.

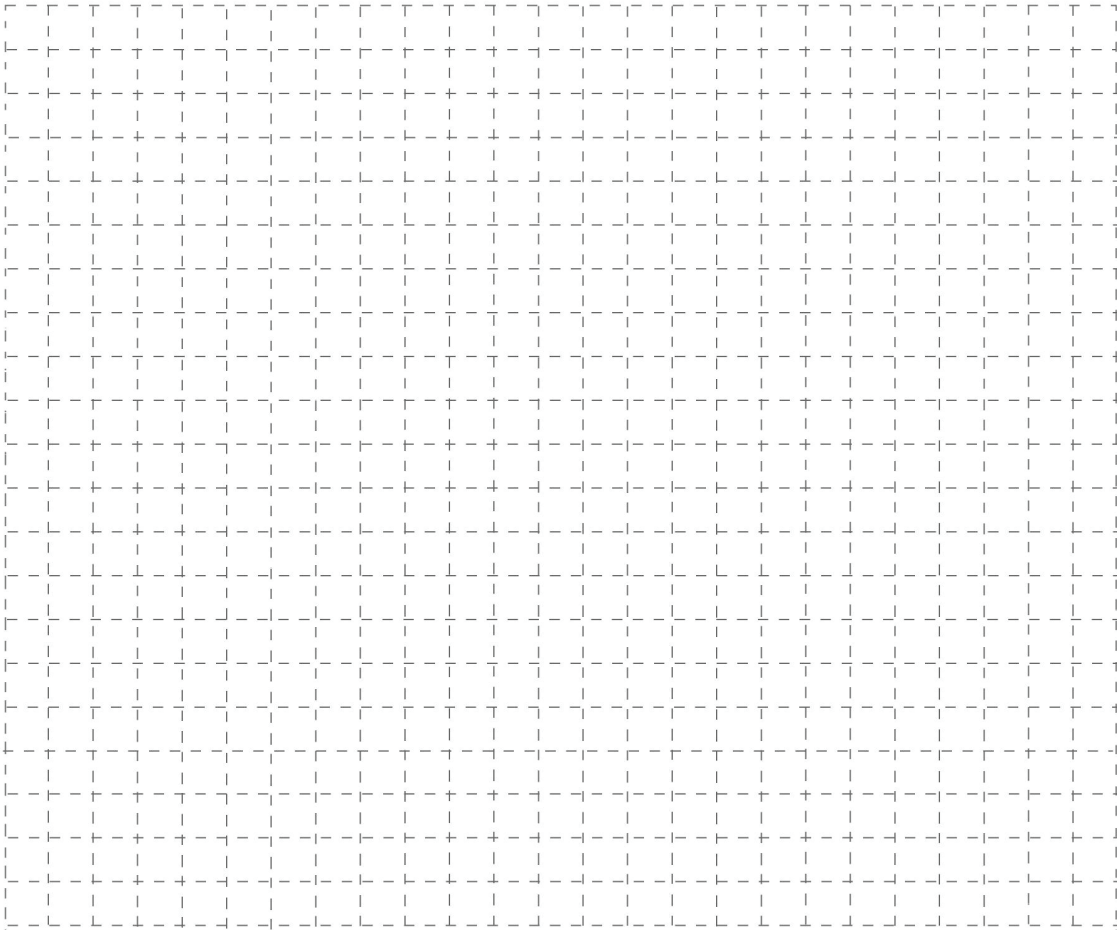
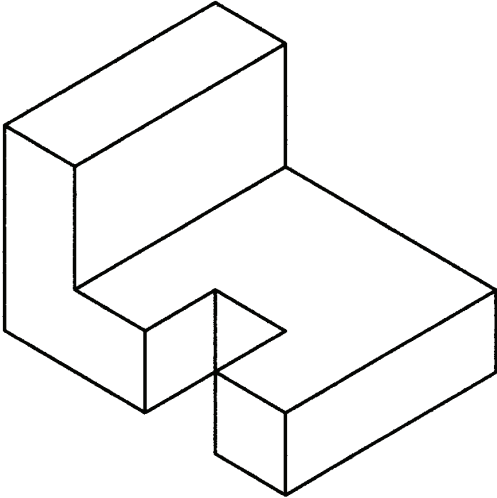

NOTES:

Name: \_\_\_\_\_ Date: \_\_\_\_\_

**P2-3)** Sketch the front, top and right side views of the following object. Use the grid provided.

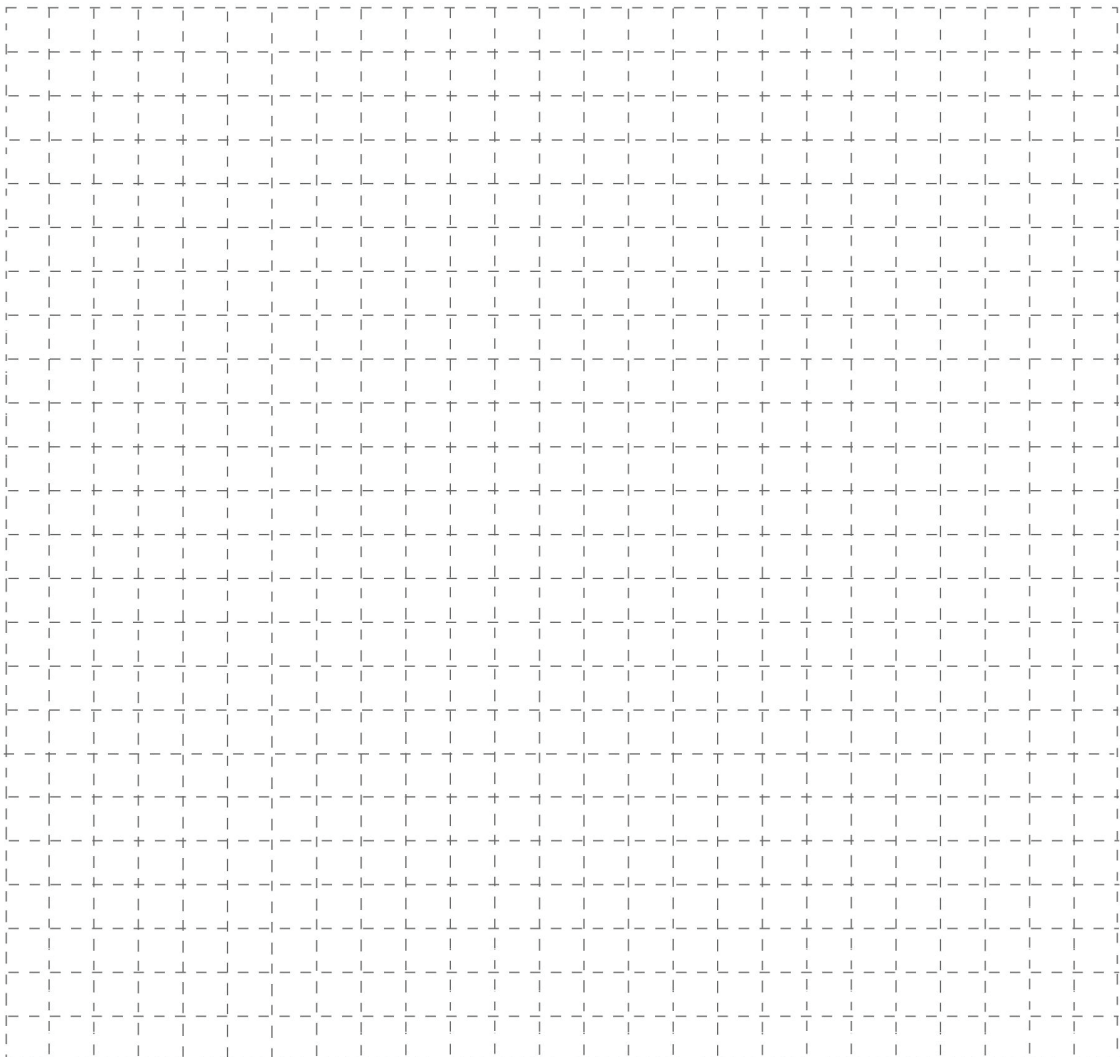
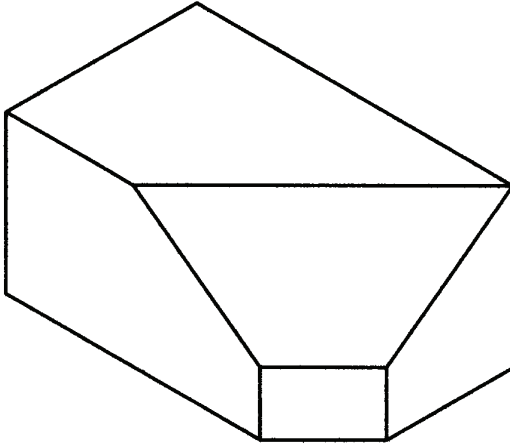

NOTES:

Name: \_\_\_\_\_ Date: \_\_\_\_\_

**P2-4)** Sketch the front, top and right side views of the following object. Use the grid provided.

