

ENGINEERING & COMPUTER GRAPHICS WORKBOOK

Using SolidWorks 2010

Ronald E. Barr
Thomas J. Krueger
Theodore A. Aanstoos
Davor Juricic

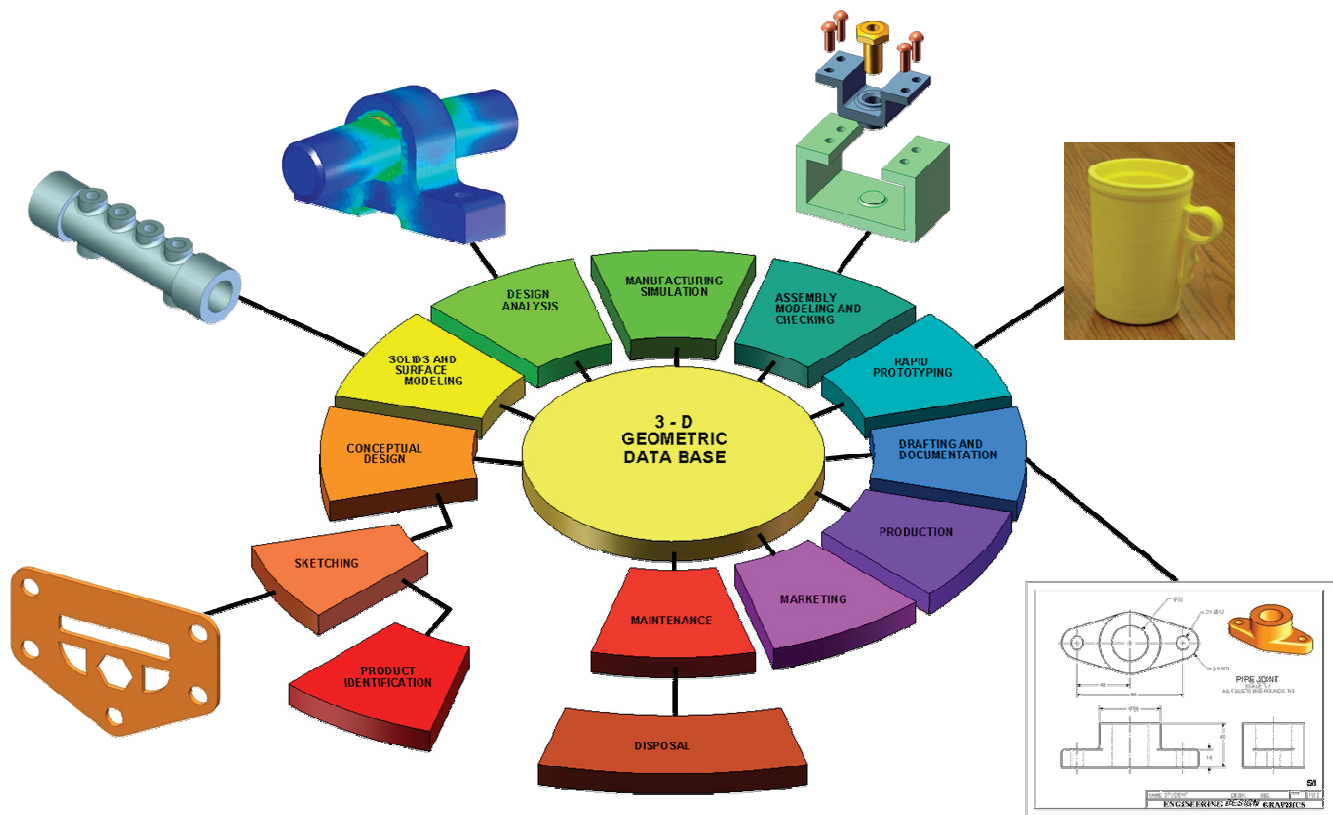

SDC
PUBLICATIONS

www.SDCpublications.com

Schroff Development Corporation

Computer Graphics Lab 1: 2-D Computer Sketching I

INTRODUCTION TO SOLIDWORKS

SolidWorks© is a parametric solid modeling package that is used to build solid computer models. The designer starts with a 2-D sketch that at first is loosely defined. Dimensions and other constraints are applied to the 2-D sketch to fully define its geometry. The sketch is turned into a 3-D solid model using an extrusion or revolution. If the base part is not correct, the designer can simply change the dimensions of the original sketch or definition of the base feature, and then re-build the part with a click of the mouse. Once the base part is defined, new sketches can be defined on planes around the base part, and they can then be extruded to form bosses and cuts on the part. Also, special design features can be easily added to the part, such as fillets, chamfers, and counter bores. This is called feature-based modeling and it is the latest approach to 3-D computer modeling. In this first computer graphics lab, you will concentrate on 2-D computer sketching methods, and will extrude or revolve simple parts. Four different, short exercises are provided.

SOLIDWORKS TOOLBARS SETUP

Your instructor will show you how to launch SolidWorks on your computer. When you first launch SolidWorks the screen will appear as shown in **Figure 1-1**. Your first task is to set up your SolidWorks screen layout to have a common appearance that will be referenced throughout this workbook. To accomplish this, follow these instructions. Go to the **View** pull-down menu on the top of screen, select **Toolbars** and activate the following toolbars:

Dimensions/Relations, Features, Sketch, Standard, Standard Views, and View, as shown in **Figure 1-2**. This will arrange the common toolbars around your screen for easy access during your exercises. Note that, until you activate a part, these toolbars are all faint in appearance, meaning you cannot access them. As you get familiar with the screen and the commands, you may choose to turn off some of these toolbars or turn others on.

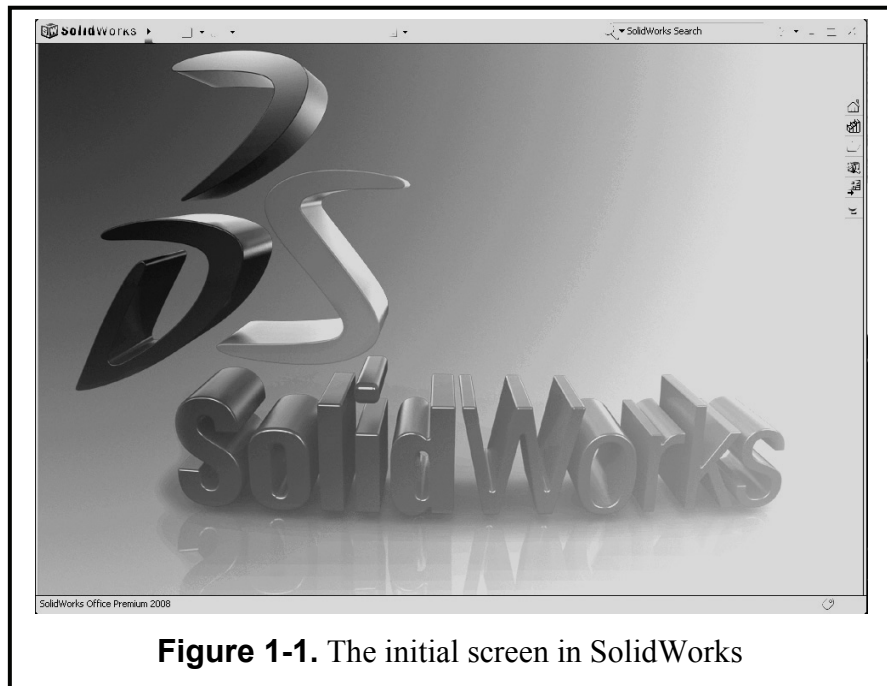

Figure 1-1. The initial screen in SolidWorks



Figure 1-2. Setting the Proper Screen Toolbars during Setup.

STARTING A NEW PART

To start your session with SolidWorks, you need to pull down the **File** main menu and click on the **New** command. This will invoke an on-screen menu, as shown in **Figure 1-3**. You have three options: Part, Assembly, and Drawing. To start a new model, click **Part** and then **OK**. Once you have clicked the OK button, the screen changes into the SolidWorks computer working space with all the previously checked toolbars ready to be used. Your first step is to study this initial screen layout as depicted in **Figure 1-4**. Some of the toolbars may appear at other positions on the screen.

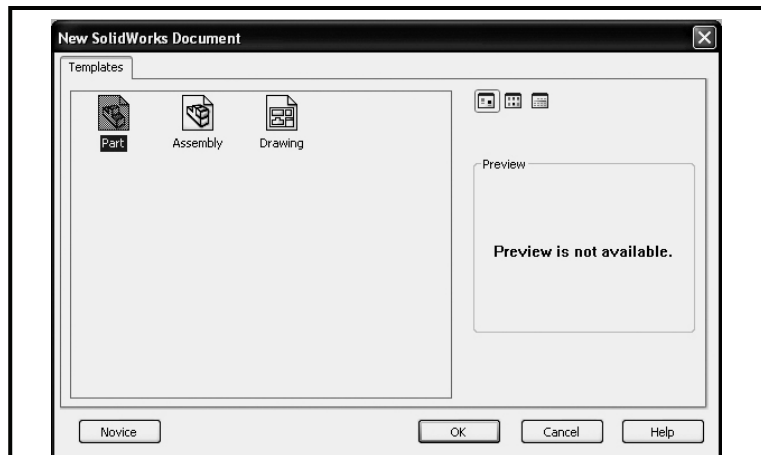

Figure 1-3. Starting a New Part in SolidWorks.

THE SOLIDWORKS SCREEN LAYOUT

The SolidWorks screen layout when you start a part uses the top, left, and right side of the screen to arrange various menus and toolbars. The center of the screen is the computer sketching area for your design work. Study **Figure 1-4** to become familiar with this standard screen layout. Each of these menus and toolbars will be described in the subsequent paragraphs.

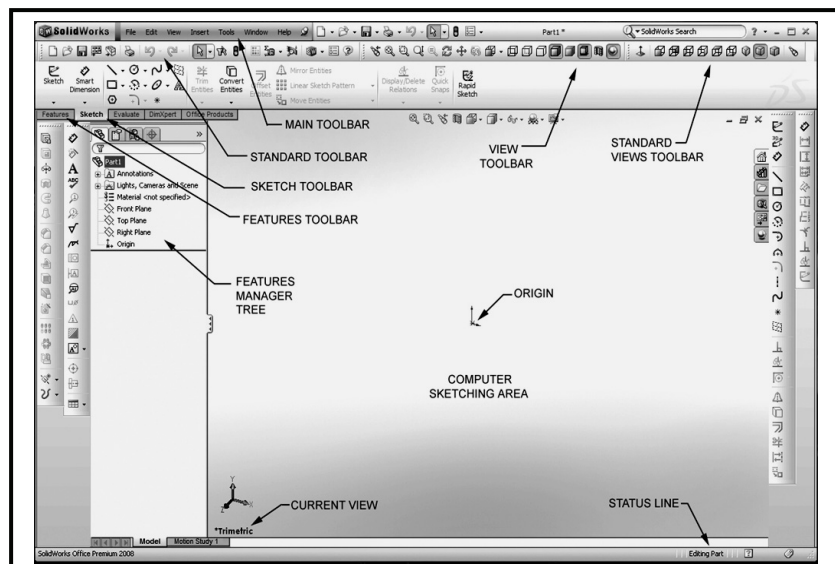

Figure 1-4. The SolidWorks Screen Layout with Major Menus and Toolbars Identified.

MAIN MENU

File is where you can create New files and Open, Save, Print Preview, and Print existing files. You also can set up your Page on this menu.

Edit is where you can Undo the last command, and Cut, Copy, and Paste Entities. It also has the Rebuild command that you may find convenient when you make changes to your model.

View is where you Redraw and set Display parameters. You can set the View Orientation, and select View commands like Zoom, Rotate, and Pan.

Insert is where the major feature creation commands are located. Here you can create the Base part, Cut the part, and invoke many of the parametric features.

Tools has an assortment of helpful commands. It has Sketching Tools, Dimensioning Tools, and Relations Tools. It also has analysis tools like Mass Properties.

Window is where you can set some window properties like vertical and horizontal tiling.

Help is where you can access on screen listings of the command functions and other information that will help you navigate and learn SolidWorks.

FEATURE MANAGER TREE

SolidWorks has a special “Feature Manager Tree” capability that keeps track of the solid modeling process. It relates each feature with the appropriate sketch in a tree diagram and allows you to edit your feature later if needed. The “Feature Manager” will appear after you have begun a new part or have opened an existing solid model. It is located in the upper left part of the screen. **Figure 1-5** shows an example of the Feature Manager.

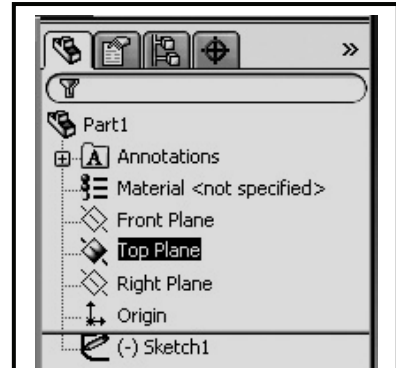

Figure 1-5. Feature Manager Tree.

THE REBUILD BUTTON

The “Rebuild Button” is located on the Standard Toolbar and looks like a red/green traffic light, as shown in **Figure 1-6**. When you press it with the mouse button, it will rebuild your model and update any changes that have been made.

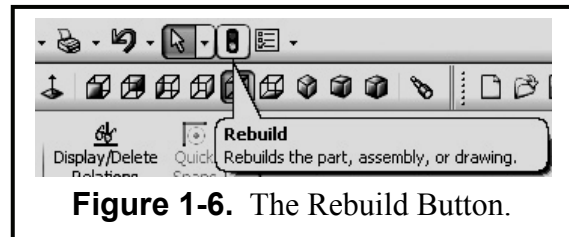

Figure 1-6. The Rebuild Button.

TOOLBARS

Toolbars are clickable icons along the top and side of the screen that permit quick and easy access to some of the more common commands used in SolidWorks. You can see the toolbars, grouped by function, in the general screen layout of **Figure 1-4** on page 1-2.

View and **Standard View Toolbars** are shown in **Figure 1-7**. The View Toolbar contains buttons for several Zoom commands, the Rotate View command, and the Pan (Move) View command. It also has icons to represent your model as a wireframe, with light gray hidden lines, with hidden lines removed, as a shaded image, and as a shaded image with a shadow. The Standard View Toolbar allows you to select Front, Back, Left, Right, Top, Bottom, Isometric, and Normal Views.

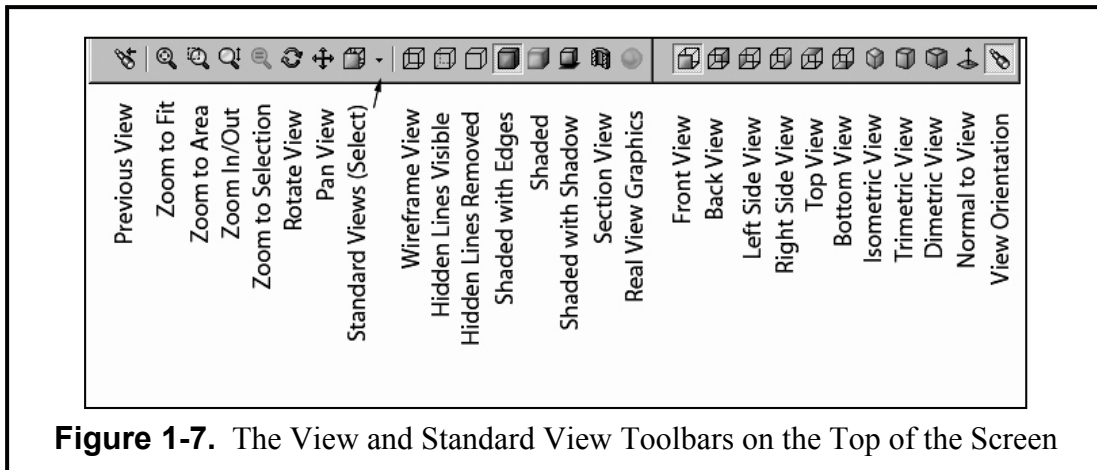

Figure 1-7. The View and Standard View Toolbars on the Top of the Screen

Sketch Toolbar is shown in **Figure 1-8**. It can be divided into sketch entities, relations, and dimension tools. To start, you click on the **Sketch** icon. As you establish 2-D sketch entities, you can use **Dimension** and **Add Relation** buttons to fix the geometric parameters of your design. To aid you in your sketching, numerous 2-D entity icons are available, such as **Line**, **Arc**, **Circle**, and **Rectangle**. To edit your sketch, several common commands like **Trim**, **Mirror**, **Fillet**, and **Offset** are available.

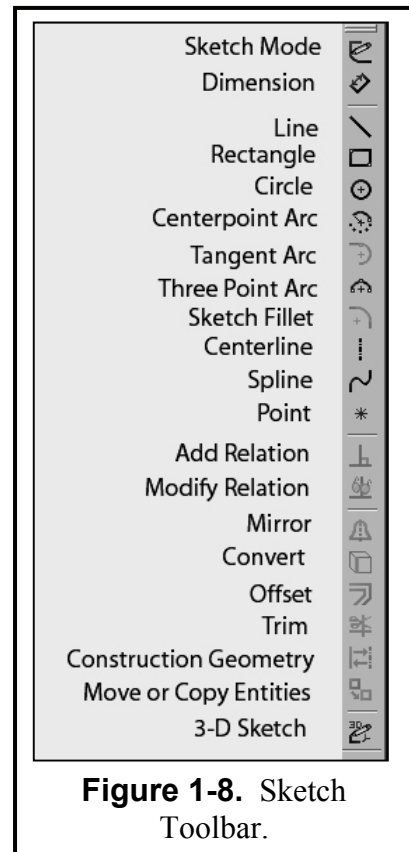

Figure 1-8. Sketch Toolbar.

SKETCHING PLANES

Before you start a 2-D sketch with SolidWorks, you must define (highlight) a sketch plane. The three default orthogonal sketch planes are the three standard orthographic view planes: **Front**, **Top**, and **Right**, as shown in **Figure 1-9**. Later, you can also pick any plane or flat surface on a base part that has been created. The surface does not necessarily have to be parallel to one of these three principal planes.

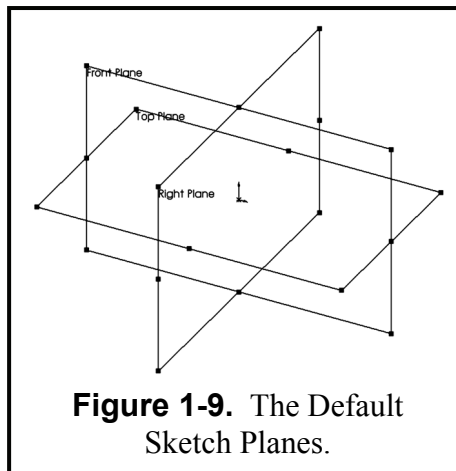

Figure 1-9. The Default Sketch Planes.

LINE COLORS

SolidWorks has several ways to feedback information to the user. One of these ways is to use different line colors. When sketching 2-D profiles, the following color codes prevail.

Green lines mean that the entities are **Selected**.

Blue lines mean that the dimensions of the geometry are **Under Defined**.

Black lines mean that the dimensions of the geometry are **Fully Defined**.

Yellow lines mean that the dimensions of the geometry are **Over Defined** (undesirable).

Gray lines mean that these entities are not in the active sketch.

STANDARD TEMPLATES

Before you start any exercises in SolidWorks, it is a good idea to establish some standard drawing templates and title blocks to reflect the two styles of engineering measurements. One set will be for the American National Standards Institute (ANSI) for Inches and the other for Metric.

To start, go to **File**, select **New**, then **Part** and **OK** this selection. Go to the **Tools** pull-down menu. Select **Options**. Under the **Document Properties** tab, make sure that the **Dimensioning Standard** is set for **ANSI** (see **Figure 1-10**). Next select **Units** in the left hand column of the menu. In the window that appears, activate **IPS (Inch, Pound, Second)**. You should also increase the Decimal Places to four (**4**) as indicated in **Figure 1-11**. Close the “Document Properties” menu with the **OK** button. Now go to **File** and select **Save As**. First select the **FOLDER** you wish to save this template in, then title your part as **ANSI-INCHES**, select **Save as Type** and select **Part Templates (*.prtdot)**. Then save it in your folder. Repeat the above process, only this time, the **Units** you select will be **MMGS (Millimeter, Gram, Second)**. Two decimals should be sufficient for metric measurements. Save this template also in your **FOLDER**, but change your title to **ANSI-METRIC** and select the **Save as Type** and select **Part Templates (*.prtdot)**.

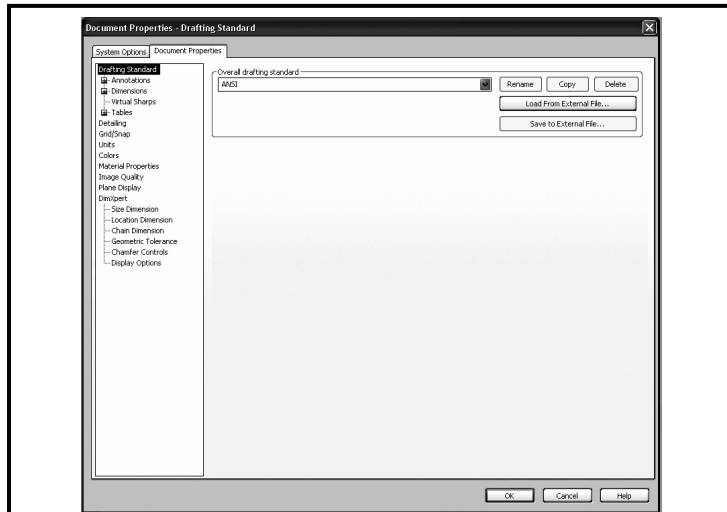

Figure 1-10. Document Properties Menu.

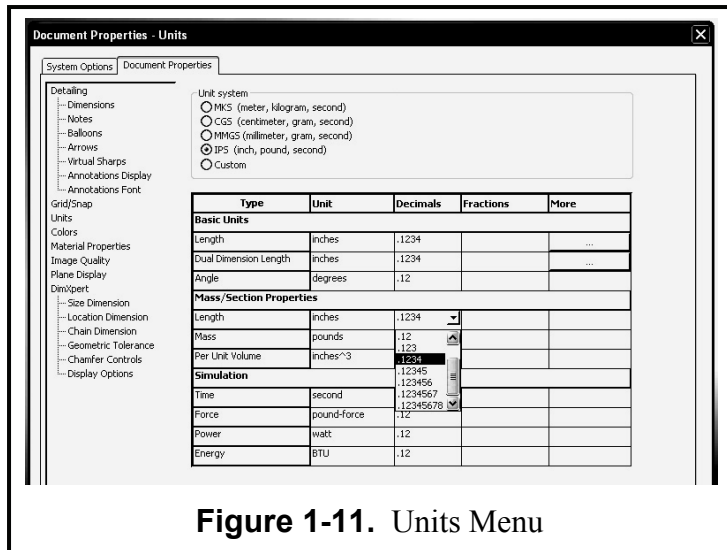

Figure 1-11. Units Menu

STANDARD TITLE BLOCK DRAWING SHEETS

The next process is to set up a Title Block to reflect the two measurement styles. You may have to draw a title block (see **Figure 1-12**) if one has not been provided. An example of a title block, with suggested dimensions and style, is available in **Appendix A**. If a Title Block has been provided, go to **File** and **Open** that drawing file. Go to the **Tools** pull-down menu and select **Options**. Under the **Document Properties** tab make sure that the **Dimensioning Standard** is set for **ANSI**. Next select **Units** in the left hand column. In the window that appears, activate **IPS (Inch, Pound, Second)**. Three **(3)** decimal places will be all you should use here unless you are doing very high tolerance drawings.

Go to **Insert – Annotations – Note** to add your personal information, such as NAME, DESK NUMBER, and SECTION NUMBER. In the **Feature Manager Tree**, right click on **Sheet 1** and select **Edit Sheet**. Now that this is done, go to **File** and **Save As**. First select the FOLDER you wish to save this template in, then title your part as **TITLEBLOCK-INCHES** and select the **Save as Type** and select **Drawing Template (*.drwdot)**.

Repeat the above process, only this time, the **Units** you select will be **MMGS (Millimeter, Gram, Second)**. Two **(2)** decimals should be sufficient for metric measurements. Add your personal information such as NAME, DESK NUMBER, and SECTION NUMBER. In the **Feature Manager Tree**, right click on **Sheet 1** and select **Edit Sheet**. Save this template in the same way, but change your title to **TITLEBLOCK-METRIC** and select the **Save as Type** and select **Drawing Template (*.drwdot)**.

INSERTING A PART (RENDERED PICTORIAL) ONTO A TITLE BLOCK SHEET

For each of the assignments you will be asked to submit a printed copy of the part that you built in SolidWorks. The following will be the procedure to accomplish this requirement.

- A. Build the solid model according to instructions and save that part in your folder with the file extension of **.sldprt**.
- B. Open the appropriate Title Block drawing sheet (see **Figure 1-12** for example). The Title Block drawing sheet that you open should have the same units as the solid part (metric or inches).
- C. Pull down **Windows** and then select **Tile Vertically**. This allows you to see all the windows that you have open at the same time.
- D. Select the Part Name in the **Feature Manager Tree** and while holding down the left mouse button, drag it onto the Title Block drawing sheet. At this time you have several options available to choose from. For most of your labs you will be choosing a pictorial view or current view. In unit nine and ten you will be choosing the three views layout of the object that you insert onto the Title Block. If you do not see the three views, right click on **Sheet 1** in the **Feature Manager Tree** and select **Edit Sheet**.

- E. Pick the window around the pictorial view. You get a menu window that lets you adjust the scale of the image to better fill the sheet.
- F. In the drawing area of the Title Block Sheet **Insert** the title of the object. Provide the exercise number in the upper right hand box of the Title Block. Your Title should be placed in an open area of the Title Block and a larger font size, i.e. **0.18** or **0.20**. Your name, desk, Sec and exercise number should be font size **0.125** or **12pt**.

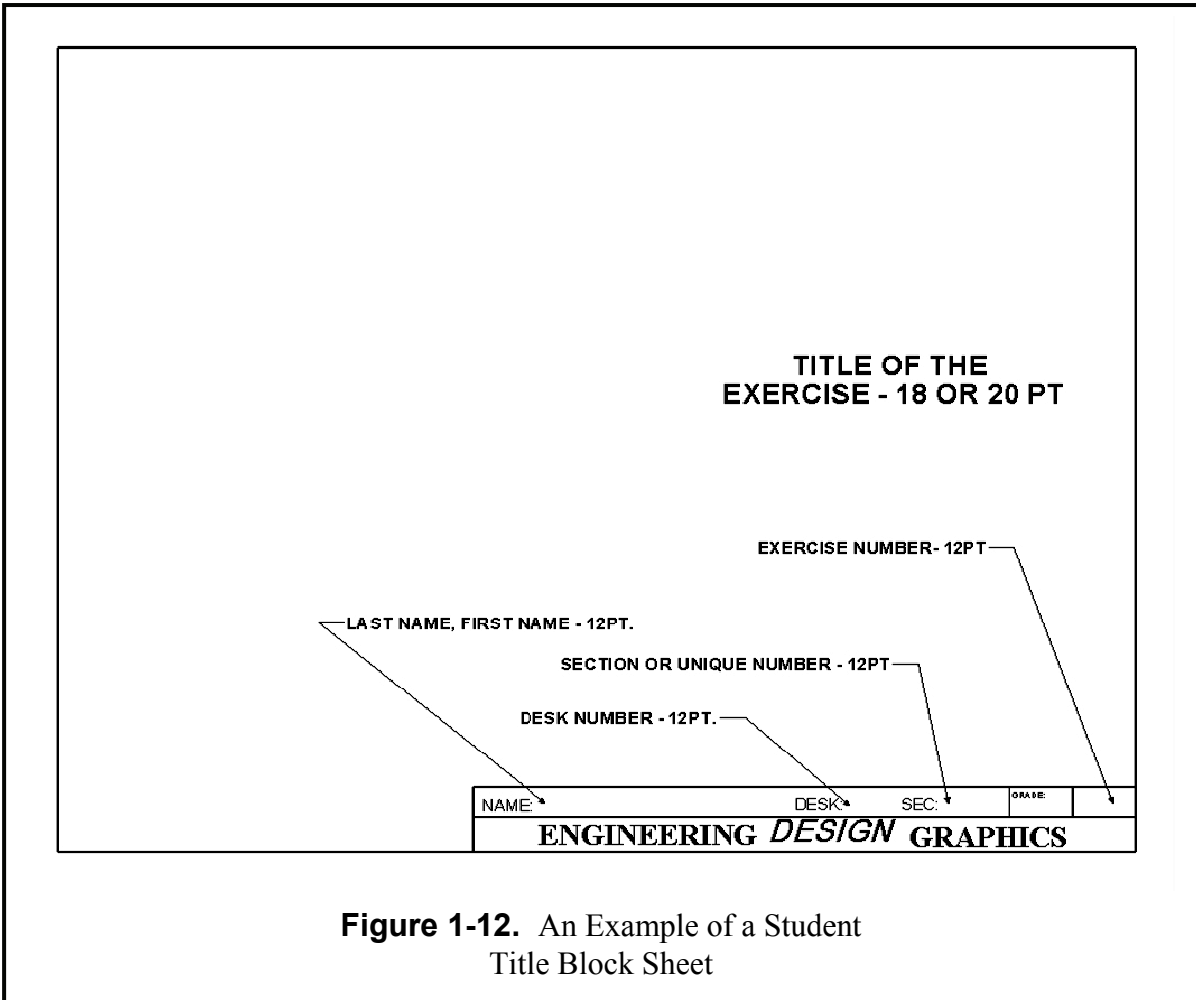

Figure 1-12. An Example of a Student Title Block Sheet

Exercise 1.1: METAL GASKET

In this first exercise, you will build a metal gasket part. This part is primarily a 2-D object with a thin depth that will be extruded. The gasket features can be drawn with many of the 2-D sketching entities and editing features using the sketch toolbars. Go to your folder and **Open** the file **ANSI-INCHES.prtdot**. In order to avoid corrupting the **ANSI-INCHES.prtdot** template go to **File – Save as:** under **File Name**, type **METAL GASKET**, and under **Save as type**, Select **.sldprt** and select **SAVE**.

First set up the sketching grid and units. Pull down the **Tools** menu and select **Options**. Under the **Document Properties** tab, click the **Grid/Snap** tab and set the “Major grid spacing” to **0.25** and “Minor lines per major” to **1**. Also click on (✓) all the “Grid” boxes and set “Snap points per minor” to **1**, as shown in **Figure 1-13**. Click on the **Go To System Snaps** and make sure that the **Grid** and **Snap** only when grid is displayed boxes are checked. Also make sure the **Units** are in **Inches** to **2** decimal places. Then click **OK** to close the menu.

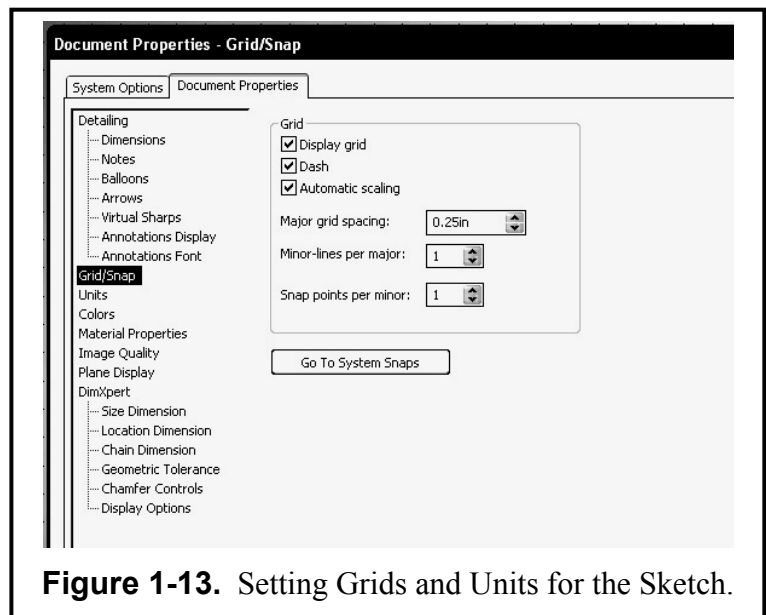

Figure 1-13. Setting Grids and Units for the Sketch.

You will design the gasket in the front view, so click on the **Front** plane in the Feature Manager tree. The front plane should highlight in green. Next click on the **Sketch** icon (drawing pencil) on the upper left side of the screen. The sketching grid will now appear on the screen with grids spaced every 0.25 inches. Also make sure you are viewing this from the **Front View** orientation (see **Figure 1-7**).

Now study the outline of the gasket shown in **Figure 1-14**. You will sketch this outline on the quarter-inch grids using the line tool. Click the **Line** icon on the sketch menu toolbar. Now draw five lines according to the specifications in **Figure 1-14** and detailed below. All **(X,Y)** coordinates are relative to the sketch “origin” seen in the middle of the screen.

The *top line* starts at **(-2.75, 1.25)** and ends at **(2.75, 1.25)**.

The *right side line* starts at **(2.75, 1.25)** and ends at **(2.75, -1.25)**.

The *bottom right diagonal line* starts at **(2.75, -1.25)** and ends at **(0.00, -2.75)**.

The *bottom left diagonal line* starts at **(0.00, -2.75)** and ends at **(-2.75, -1.25)**.

The *left side line* starts at **(-2.75, -1.25)** and ends at **(-2.75, 1.25)**.

The 2-D outline of the gasket should now be finished and completely enclosed.

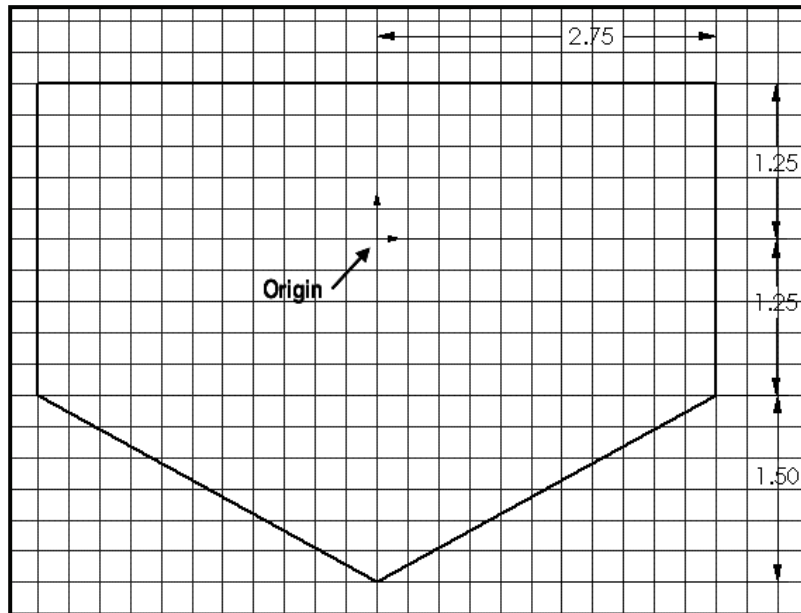

Figure 1-14. The Beginning Outline for the Metal Gasket.

Using the **Rectangle** sketching tool, draw a rectangular slot **3.00** inches wide by **0.50** inches high, and completely centered on the origin, as shown in **Figure 1-15**. Next select the **Circle** sketching tool, and create the five circles along the corners of the outline. All circles have the same diameter of **0.50** inches and are positioned as indicated in **Figure 1-15**. *Note:* While you are sketching the lines, rectangle, or circles, the end of the cursor pencil shows a small icon that indicates the current type of sketch entity that you are using. This is called a “smart cursor.”

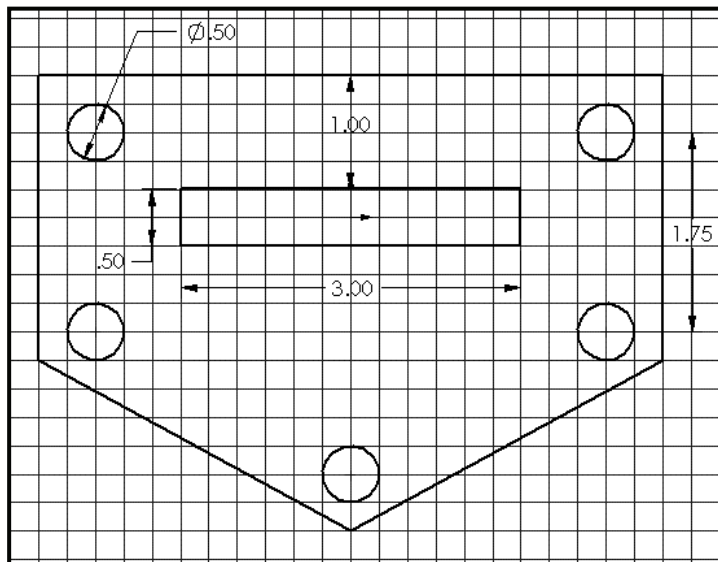

Figure 1-15. Adding the Five Circular Features and Rectangular Slot.

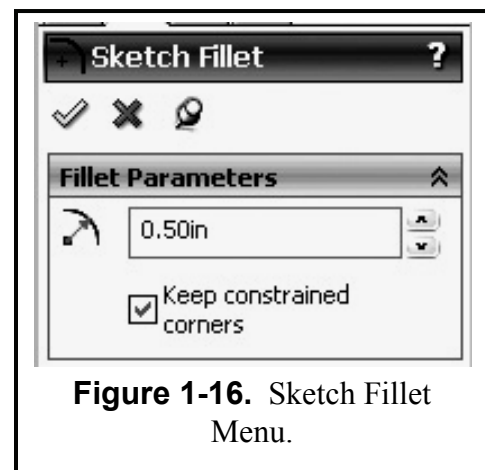

Figure 1-16. Sketch Fillet Menu.

The five corners of the gasket are sharp and need to be rounded. This can easily be accomplished using the fillet editing command. Click the **Fillet** icon (round corner symbol) on the sketching toolbar. Notice that a “Sketch Fillet” menu now appears where the Feature Manger tree usually is displayed (**Figure 1-16**). Key in a fillet radius of **0.50** inches. Now, one by one, click on the two edges of the corners (or merely click on the point of intersection) to create a fillet there. Once the five fillets are added, click on the green (✓) button on the “Sketch Fillet” menu. The five fillets are now completed as shown later in **Figure 1-18**. Now that you know how to add fillets, add four more **Fillet**s to the inner corners of the rectangular slot. Use a radius of **0.125**.

Now you will draw a polygon on the gasket. Pull down **Tools**, select **Sketch Entities**, and then select **Polygon**. The “Polygon” menu appears on the screen where the previous fillet menu appeared. **First draw the polygon on the gasket in its approximate position.** Now study the actual parameters needed for the polygon and then set them as shown in **Figure 1-17**.

- Number of sides = **6**
- Inscribed circle **dot**
- X-origin = **0.00**
- Y-origin = **-1.00**
- Inscribed circle diameter = **1.00**
- Rotation angle = **0°**

Once the parameters are set, click on the green (✓) button on the “Polygon” menu to close the menu and complete the polygon, as shown in **Figure 1-18**.

The next feature to sketch is a “fan” shaped quarter-circle. First, sketch a horizontal **Line** from **(1.50, -0.50)** to **(0.75, -0.50)**. Then draw a vertical **Line** from **(0.75, -0.50)** to **(0.75, -1.25)**. To add the quarter circle arc, select the **Centerpoint Arc** sketching icon. Click the center of the arc to be at the intersection of the two lines just drawn. Hold the left mouse button (**LMB**) down and drag the cursor down to the end of the vertical line. Click the **LMB** at that point to define one end of the arc. Then hold it down and drag it to the end of the horizontal line. Once again, click the **LMB** at that point to complete the arc. You should have a drawn arc feature as shown in **Figure 1-18**.

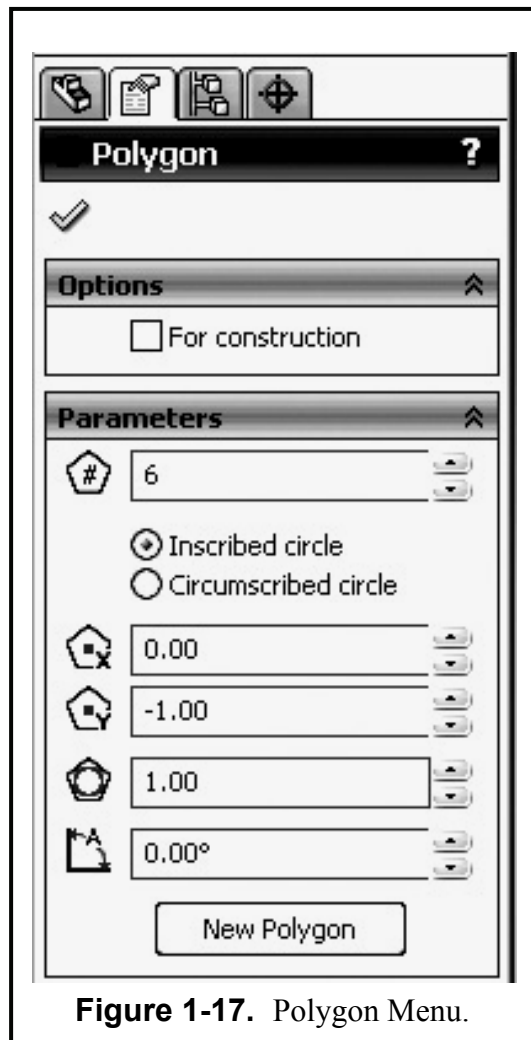

Figure 1-17. Polygon Menu.

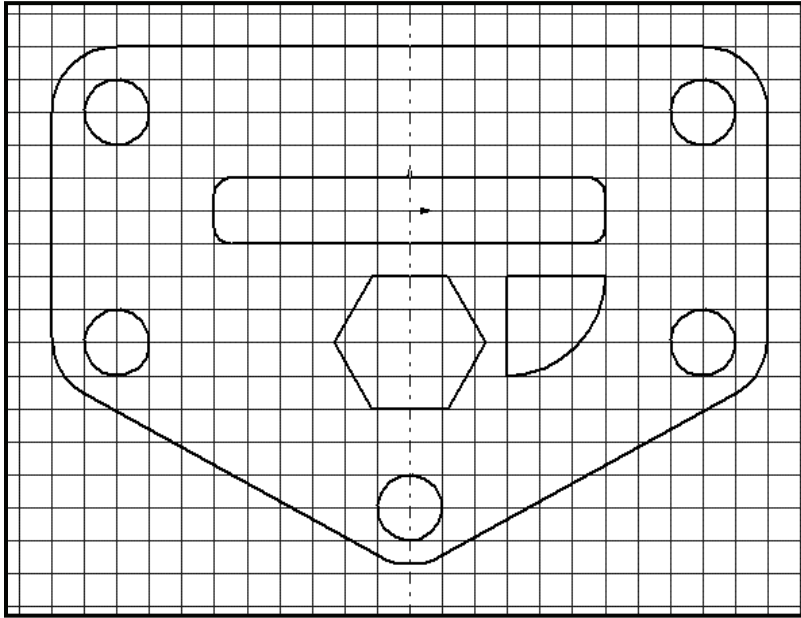

Figure 1-18. Sketching the Polygon and Right Side Fan-Shaped Arc.

You now need to finish the gasket by creating a symmetric arc feature on the left side of the polygon. SolidWorks offers many tools for sketching and editing. One of these tools is the “Mirror” sketch feature about a centerline. Select the **Centerline** sketch icon, which is in the pull down menu of the line command, and draw a centerline vertically from top to bottom, and through the origin, as shown in **Figure 1-18** above. Click the **Select (LMB)** button. Now hold down the Control (**Ctrl**) key and select the following: the centerline, horizontal line of the arc, vertical line of the arc, and the arc itself. Now click the **Mirror** (bell-shaped) icon. The fan-shaped arc feature will now mirror to the left side. The gasket outline is now complete as shown in **Figure 1-19**.

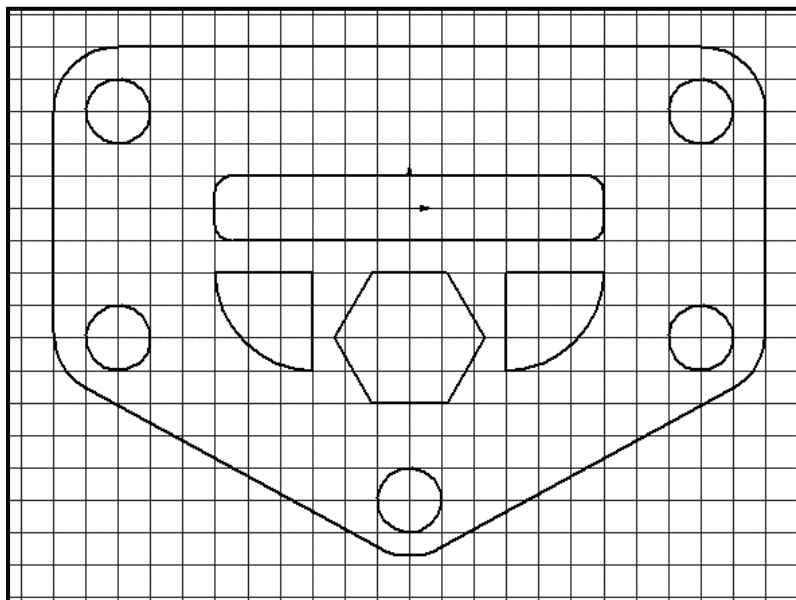

Figure 1-19. The Finished 2-D Sketch of the Gasket.

EXTRUDING THE GASKET THICKNESS

The gasket can now be extruded to its proper thickness. Select the **Features** icon and select **Extrude** or pull down the **Insert** main menu, select **Boss/Base**, and then **Extrude**, as shown in **Figure 1-20**. The “Extrude” menu then appears on the screen in the Feature Manager area (**Figure 1-21**). Set the parameters for the extrusion:

Direction One = **Blind**
Distance1 = **0.125** inches

Notice that the extrusion appears as a preview in the computer sketching area in an Isometric view. Click on (✓) the green button on the “Extrude” menu to finish.

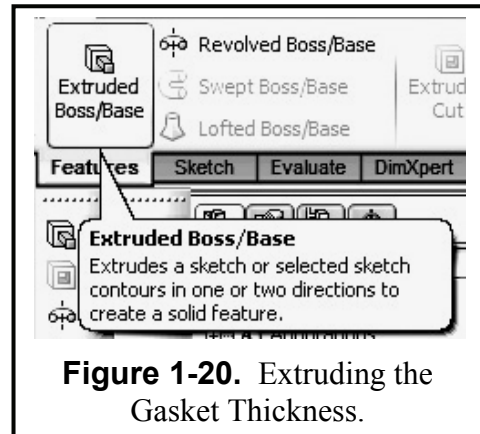

Figure 1-20. Extruding the Gasket Thickness.

Now you can view your model. On the “View Orientation” window (you should have it push-pinned onto the screen) click **Trimetric**. You should see the thin solid model appear as a trimetric view (see **Figure 1-22**). Also try **Isometric**, **Dimetric**, and **Front** view orientations. You can experiment with some of the viewing operations in SolidWorks. Click the **Rotate View** icon (it appears as circular arrows on the top toolbars). Now rotate your model into different configurations. Also try several **Zoom** commands and the **Pan** command.

If you would like to change the color of your model, click on the model name in the Feature manager tree and then select the colored ball in the menu bar. You can then assign any color you wish to the model.

You should save your model. Now save your model. Pull down the **File** menu and select **Save As**. On the “Save As” menu, select your appropriate file folder in your account, type in the part name **METAL GASKET**, and the file type as **sldprt**, then click **Save**.

Before you finish this exercise, you should print a hard copy for submission to your instructor. *Check with your instructor first for any special printing instructions.* You may need to use a special sheet like the Title Sheet shown in **Figure 1-12**. You can insert the rendered Metal Gasket image into your **Title Block** drawing sheet that was created in the introduction to this chapter, as shown in **Figure 1-22**. To put this object on a Title Sheet, follow the instructions on **Page 1-7**.

Conversely, you can place your name and class data on the printed drawing. Pull down the **Insert** menu, select **Annotations**, then **Note**. A note box appears at the end of the cursor and a “Note” menu appears in the Feature Manager area. Type in your name and class data in the note box.

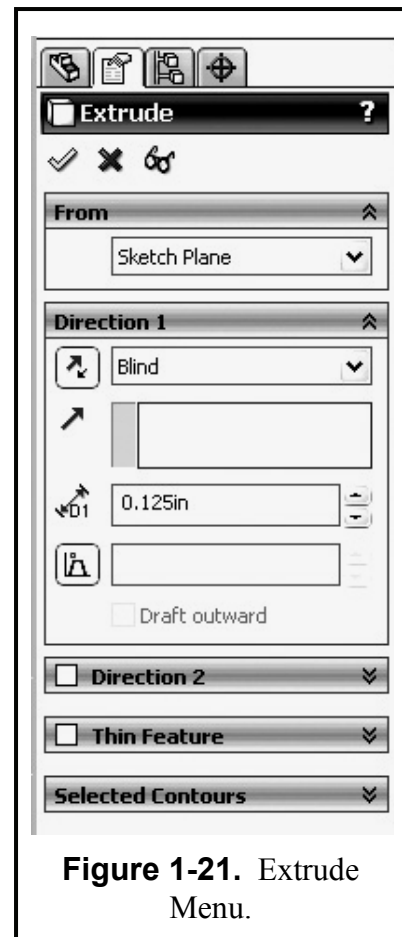

Figure 1-21. Extrude Menu.

If you check (√) **off** the “Use documents Font” in the menu, you can change the font, for example to:

Font = **Arial**
Font Style = **Regular**
Points = **12**

Now **SAVE** your drawing sheet to your directory as **METAL GASKET.slddrw**. Take note that the title of the part and the drawing are the same but the extension has changed. The solid model and the drawing are linked, meaning that any changes made to the solid model will automatically be updated on the drawing.

Before you print your copy, make sure you have set the **File, Page Setup** to **Landscape** mode. Now pull down the **File** and **Print Preview** commands from the top main menu, then the **Print** button to send it to the default printer.

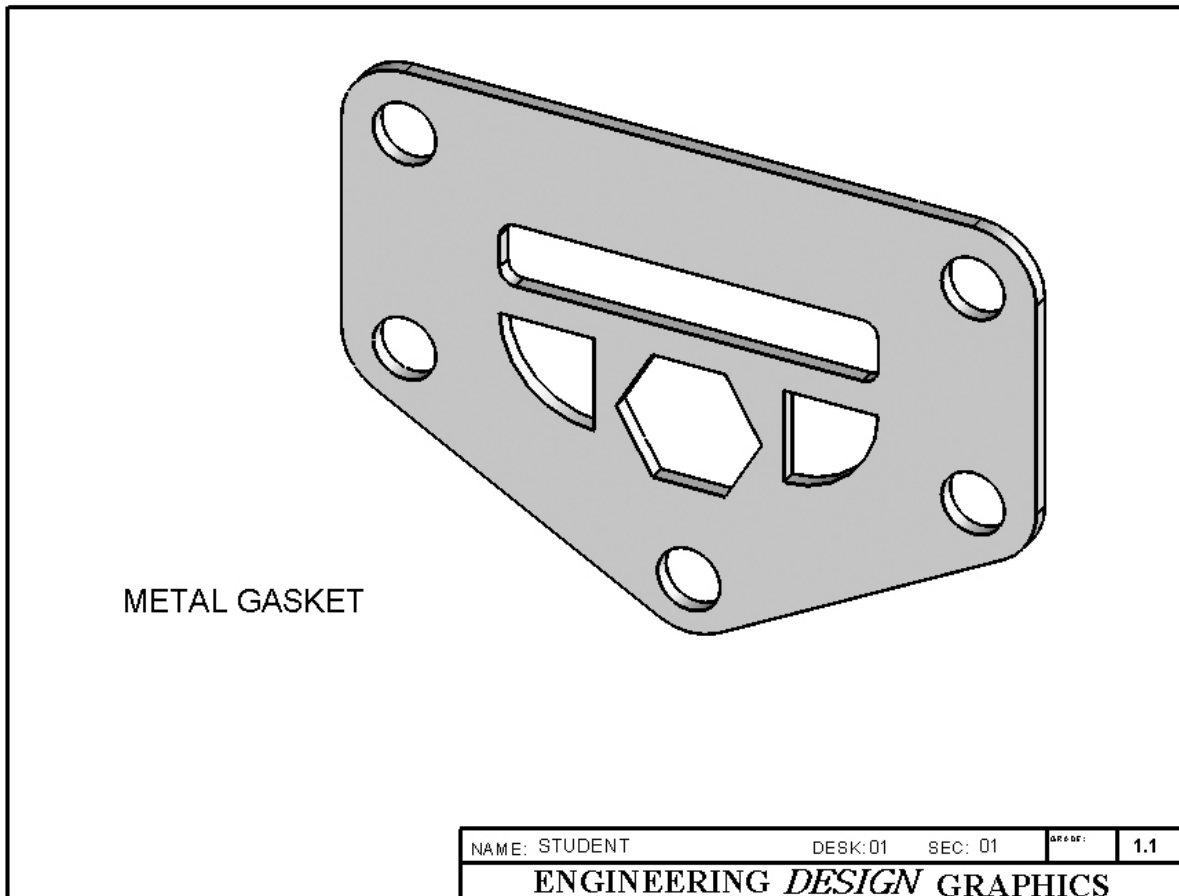

Figure 1-22. Metal Gasket Model Inserted into the Title Block Drawing Sheet.

Exercise 1.2: COVER PLATE

There are many different approaches to creating a 2-D computer sketch using SolidWorks. The approach will depend on the design intent and also on the designer's own preferences and choices. In the previous Exercise 1.1, geometry was constructed on a frontal plane using X-Y coordinate geometry and a grid system. In this Exercise 1.2, you will construct the 2-D geometry on a horizontal (top) plane since this is the normal orientation of the cover plate. Also, instead of using a grid coordinate system for laying out the design, you will use simple dimensions related to the geometry and to the computer space origin.

Go to your folder and **Open** the file **ANSI-INCHES.prt**. In order to avoid corrupting the **ANSI-INCHES.prt** template go to **File – Save as:** under **File Name**, type **COVER PLATE**, and under **Save as type**, Select **.sldprt** and select **SAVE**. Click the **Top** plane in the “Feature Manager.” Also click **Top** view in the Standard View toolbar to see the top plane in *green* on the screen. Now click the **Sketch** icon on the upper left toolbar, then click the **Circle** icon. Draw a large circle that is centered at the origin. For now, the diameter is unimportant because you will dimension it. Click the **Dimension** icon (slanted dimension line) on the right toolbar. Pick a point on the circumference of the circle and drag the dimension out to the upper right side of the circle. The dimension is not likely to be correct, as soon as you place the dimension a small Modify box appears (see **Figure 1-23**). Key in **10.00** inches and click the green (✓) check box. The diameter of the circle changes to the new value. If the circle gets too big, use **Zoom** to see it better.

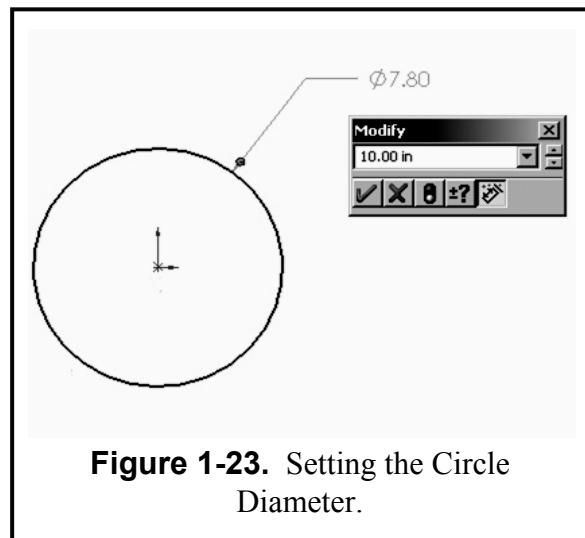

Figure 1-23. Setting the Circle Diameter.

Now you will extrude the circle into the solid base part of the cover plate. Select the **Features** icon and select **Extrude** or pull down **Insert**, select **Boss/Base**, and then **Extrude**. Set the parameters for the extrude to be:

Direction One = **Blind**
Distance1 = **0.50** inches

Click the green (✓) button on the “Extrude” menu to finish. View the cover plate as an **Isometric** (**Figure 1-24**).

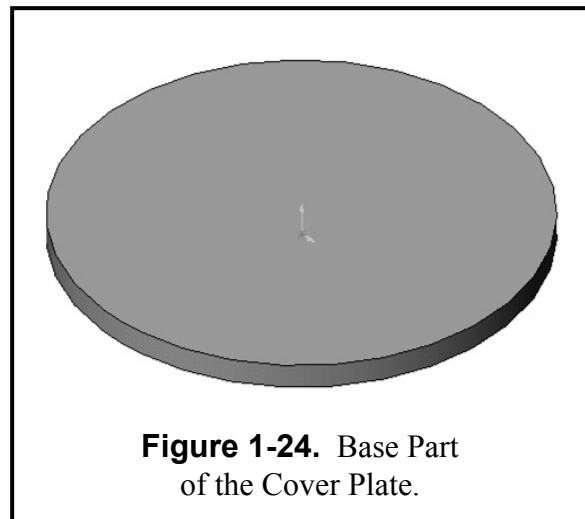

Figure 1-24. Base Part of the Cover Plate.

You will now draw the geometry for the indentation part of the cover plate. **Click on the top surface of the Cover Plate model** and it should turn *cyan*. This will be the next sketch surface. Also select **Top** on “View Orientation” for better viewing of the sketch plane. Click the **Sketch** icon to start the next sketch. Select **Circle** and draw a circle centered at the origin. Now draw a second bigger circle centered at the origin, but not as big as the 10.00 inch diameter of the base plate. Now, using the **Dimension** icon, set the diameter of the smaller new circle to **4.00** inches and the diameter of the bigger new circle to **8.00** inches.

Using the **Line** sketching tool, draw two parallel lines across the plate. One line should be slightly above the origin, and the other should be below. Both should span across the two circles as shown in **Figure 1-25**. Next **Dimension** them so that one line is **0.50** inches above the origin, and the other is **0.50** inches below the origin. This places the parallel lines 1.00 inch apart, as indicated in **Figure 1-25**.

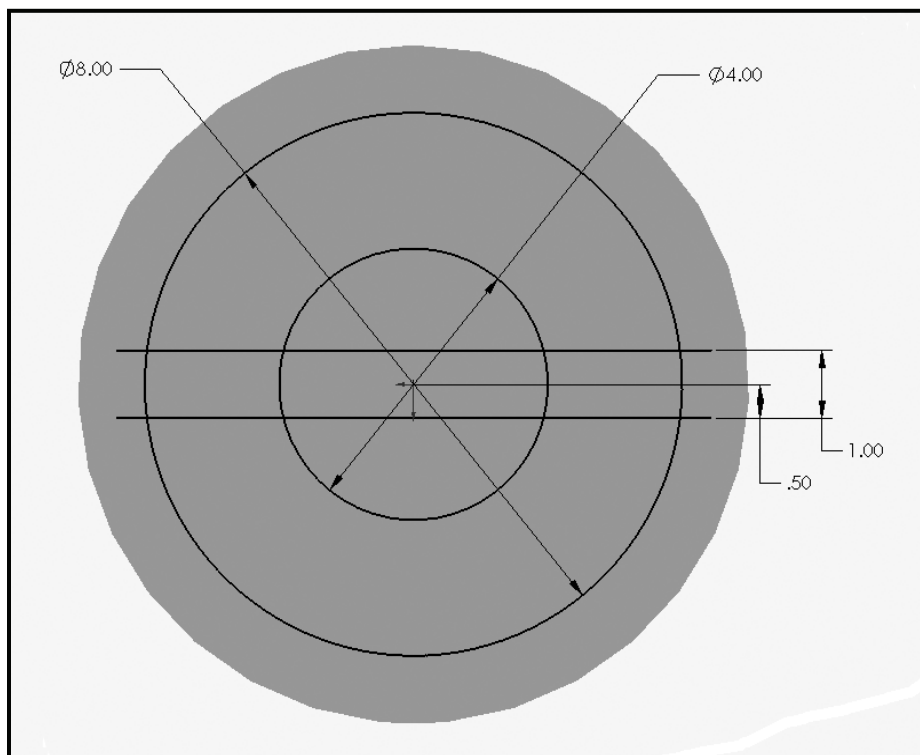

Figure 1-25. The Beginning Geometry for the Indentation.

Now you will trim these lines. Now select the **Trim** icon on the sketch editing toolbar. In the area where the Feature Manager tree is you will see a **Trim – Options** box. Select the last option (**Trim to Closest**). A scissors icon now appears on the end of the cursor indicating that you are in the trim mode. Trim the line portions (four places) that extend beyond the big circle by just clicking on them with the **LMB**. Next trim the two line pieces inside the small circle. Finally trim the portions of the circles that cross between the two parallel lines (four places). You should now have a pattern like in **Figure 1-26**. Now repeat the above process (**Line, Dimension, Trim**) to create identical patterns in the vertical direction. This final pattern for the indentation is shown in **Figure 1-27**.

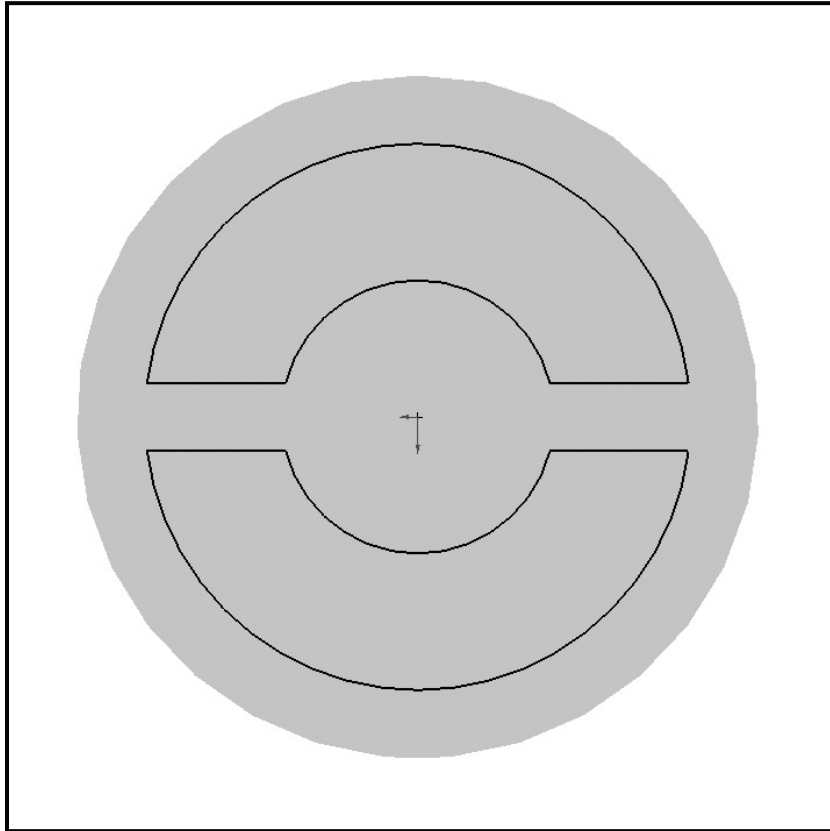

Figure 1-26. The Initial Pattern after Trimming the Lines and the Circles.

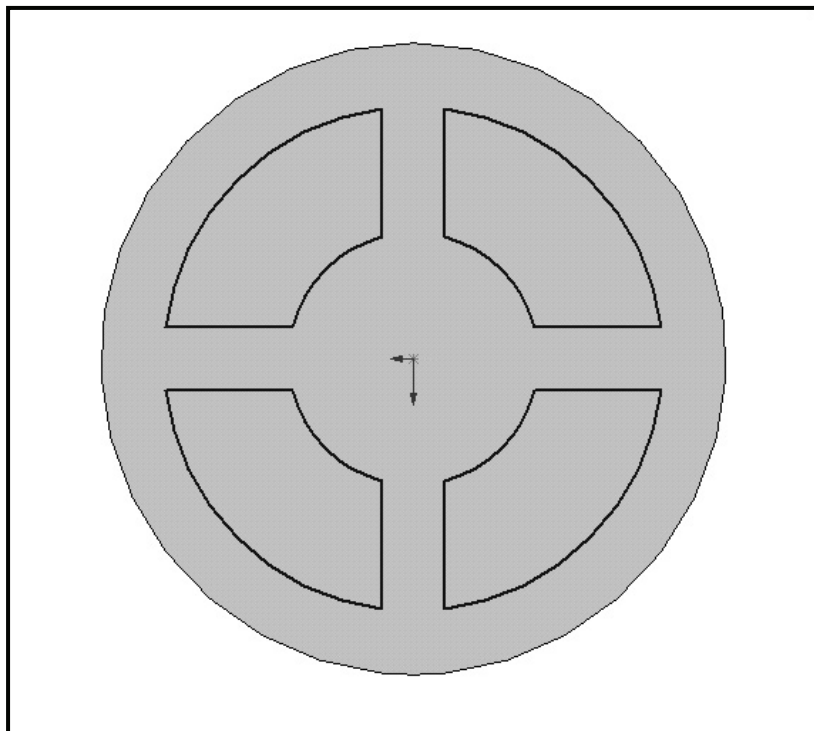

Figure 1-27. The Finished Pattern for the Indentation.

Now you will cut the indentation pattern into the cover plate. It is advisable to **go to an Isometric** view when executing an extrusion of any kind. Select the **Features** icon and select **Extruded Cut** or pull down **Insert**, select **Cut**, and then **Extrude**. The “Cut Extrude” menu appears in the Feature Manager area. Key in these parameters:

Direction One = **Blind**
 Distance1 = **0.25** inches

Click the green (✓) button to finish. View the cover plate as a rotated **Isometric** (Figure 1-28).

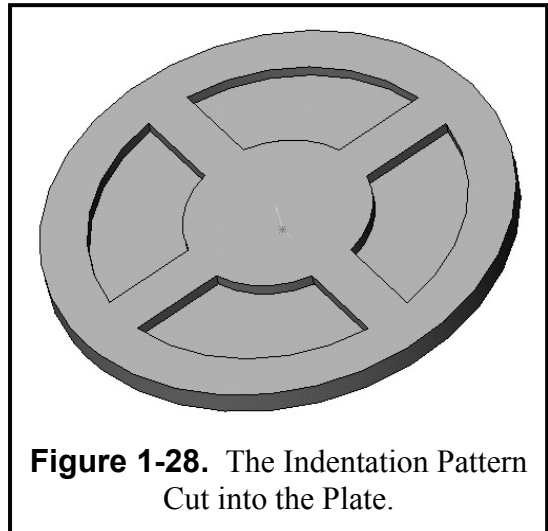

Figure 1-28. The Indentation Pattern Cut into the Plate.

Now create the lift hole in the middle of the plate. Click the cursor on the top center surface of the cover plate (it should turn *cyan*). Also, select a **Top** view orientation. You might also need to **Zoom** in to see the center portion better. Click the **Sketch** icon to get into the sketching mode. Since the lift hole is symmetric about the origin, you can use a mirror function. So start by drawing a vertical **Centerline** (CL) through the origin. Draw a small **Circle** to the right side of the centerline. Then draw two parallel **Lines** that start at the centerline and go through part of the circle, as indicated in **Figure 1-29**. Now apply the following inch **Dimensions** to the sketch geometry.

Circle Diameter = **0.75**
 Lateral Dist. from CL = **0.75**
 Line1 from origin = **0.20** (above)
 Line2 from origin = **0.20** (below)
 Circle center = **0.20** (above Line2)

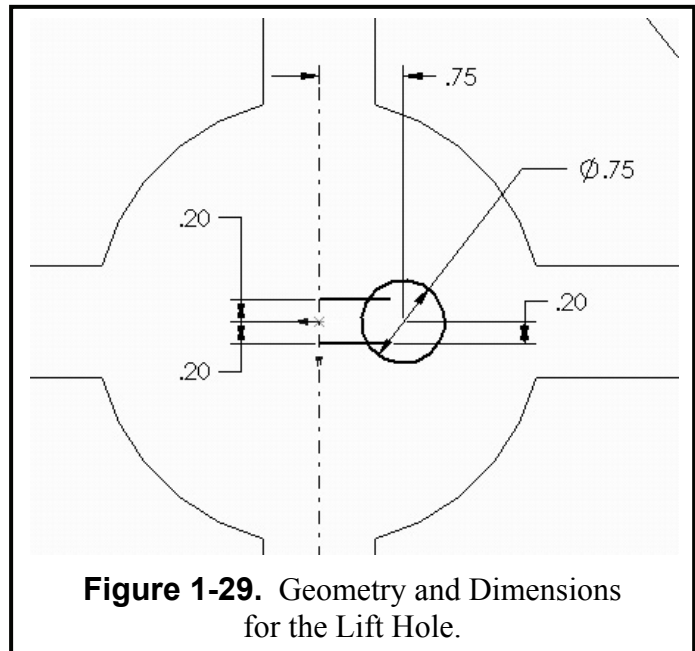

Figure 1-29. Geometry and Dimensions for the Lift Hole.

Now **Trim** the two line pieces that overhang the circle, and then trim the part of the circle between the two parallel lines. If you get a warning from SolidWorks about eliminating associated dimensions while you are trimming, just ignore it and answer **Yes** to proceed with the trim.

To mirror the feature to the left side of the centerline, hold down the Control (**Ctrl**) key and select the following: the centerline, the top line, the circle, and the bottom line. Then click the **Mirror** icon. The feature should mirror to the left and the lift hole sketch is complete. Cut the lift hole pattern through the cover plate. It is advisable to **go to an Isometric view** when executing an extrusion of any kind. Select the **Features** icon and select **Extruded Cut** or pull down **Insert**, select **Cut**, and then **Extrude**. The “Cut Extrude” menu appears in the Feature Manager area. For Direction1, just select **Through All**. Click the green (✓) button to finish this extrude-cut operation and view the lift hole in **Figure 1-30**.

To finish the cover plate, you need to add four circles around the perimeter to make the guide holes. Click the cursor on the top surface again and **Sketch** four **Circles** around the perimeter of the cover plate. The circles should be at 90 degrees to each other. The centers should be on the perimeter and aligned with the origin. The diameter of all four circles should be **0.75**, as shown in **Figure 1-30**.

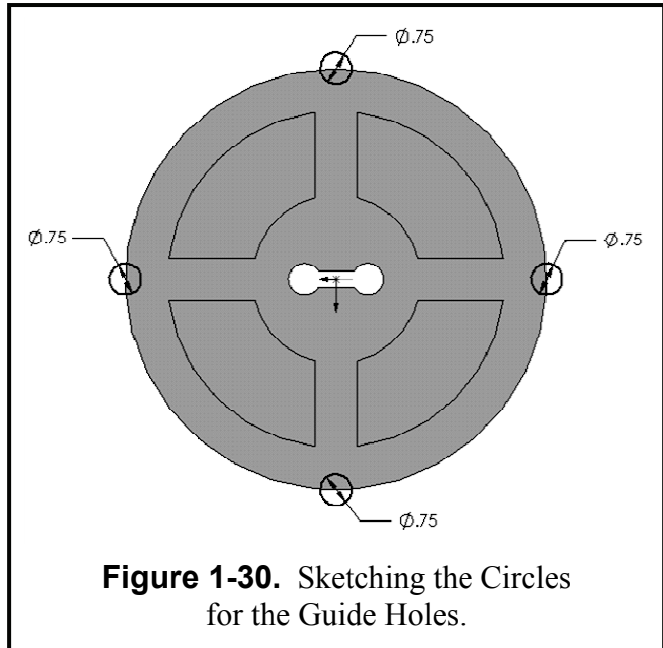

Figure 1-30. Sketching the Circles for the Guide Holes.

Now pull down **Insert**, select **Cut**, and then **Extrude**. The “Cut Extrude” menu appears in the Feature Manager area. For Direction1, just select **Through All**, and click the green (✓) button to finish the part. Now view your model in an **Isometric** view, as shown in **Figure 1-31**.

If you would like to change the color of your model, click on the model name in the Feature manager tree and then select the colored ball in the menu bar. You can then assign any color you wish to the model.

You should now save your model. Pull down **File**, select your file folder, select **Save As**, type in the part name **COVER PLATE.sldprt**, then click **Save**. Insert the rendered Cover Plate

image into your **Title Block** drawing sheet that was created in the introduction to Chapter 1 (See **Figure 1-31**. Follow the instruction given on **Page 1-7**. Now **SAVE** your drawing sheet to your directory as **COVER PLATE.slddrw**. Take note that the title of the part and the drawing are the same but the extension has changed. The solid model and the drawing are linked, meaning that any changes made to the solid model will automatically be updated on the drawing.

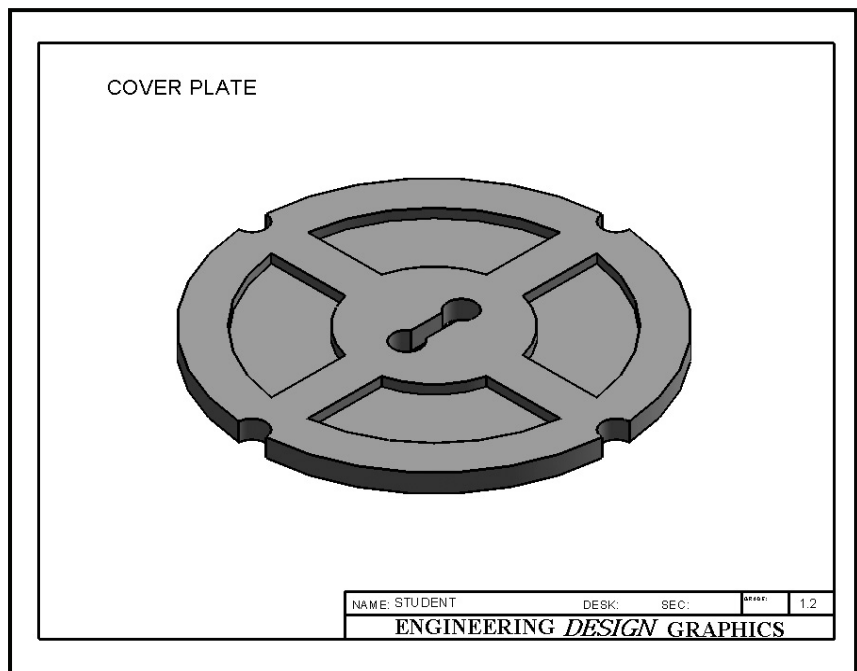
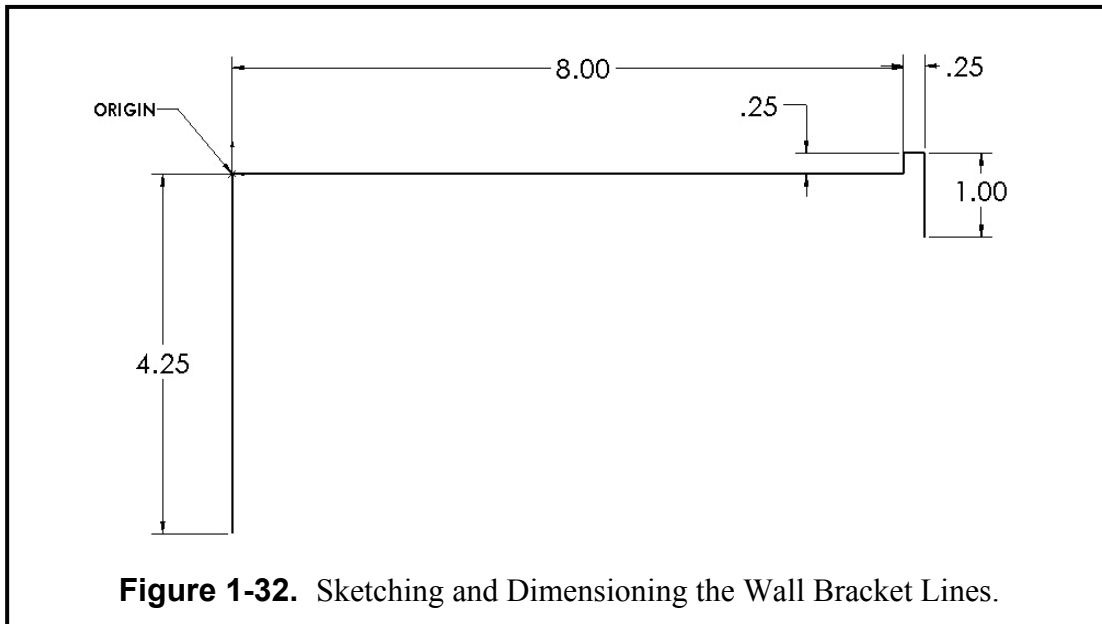

Figure 1-31. The Finished Cover Plate Part.

Exercise 1.3: WALL BRACKET

The sketch geometry used in Exercises 1.1 and 1.2, like line, circle, rectangle, and arc, are sufficient for designing many different kinds of parts. Sometimes more advanced 2-D geometry, like an irregular curve, may be needed to complete a design. In the case of the Wall Bracket for this Exercise 1.3, you will learn how to use a spline.

Go to your folder and **Open** the file **ANSI-INCHES.prtdot**. In order to avoid corrupting the **ANSI-INCHES.prtdot** template go to **File – Save as:** under **File Name**, type **WALL BRACKET**, and under **Save as type**, Select **.sldprt** and select **SAVE**. Click the **Front** plane in the “Feature Manager.” Also click **Front** view in the Standard View toolbar to see the front plane in *cyan* on the screen. Now click the **Sketch** icon on the right toolbar. First sketch the straight line segments of the Wall Bracket outline using the **Line** tool. Refer to **Figure 1-32** for the proper **Dimension** for each line segment. Units are in inches and the upper left corner is at the origin.



Now you will draw a spline from the bottom of the 4.25 inch line to the bottom of the 1.00 inch line. Click the **Spline** sketch icon (it looks like a sine wave). Click the **LMB** at the first bottom point. Then with the mouse pressed down, drag the spline over to the first intermediate point about one third of the way up and about one third of the way to the right. Release the **LMB** there, then press it down again and drag the spline to the second intermediate point about two thirds of the way up and over. Again release the **LMB** there, then press it down again and drag the spline to the final point, where you end the spline by double clicking the **LMB**. Refer to **Figure 1-33** for these four points' positions.

The two intermediate points are used to control the shape of the spline. With the **Select** cursor, pick the spline (it should highlight *cyan* with its four points identified). Now pick intermediate

point 1 and drag it out and down a little to create a slight bulge. Next pick intermediate point 2 and pull it up a little to create a slight inflection (see **Figure 1-34**). *Note:* There are no exact X-Y coordinates for you to drag these intermediate points to. Just try it a few times until you achieve a shape that pleases you (for example the shape in **Figure 1-34** is acceptable).

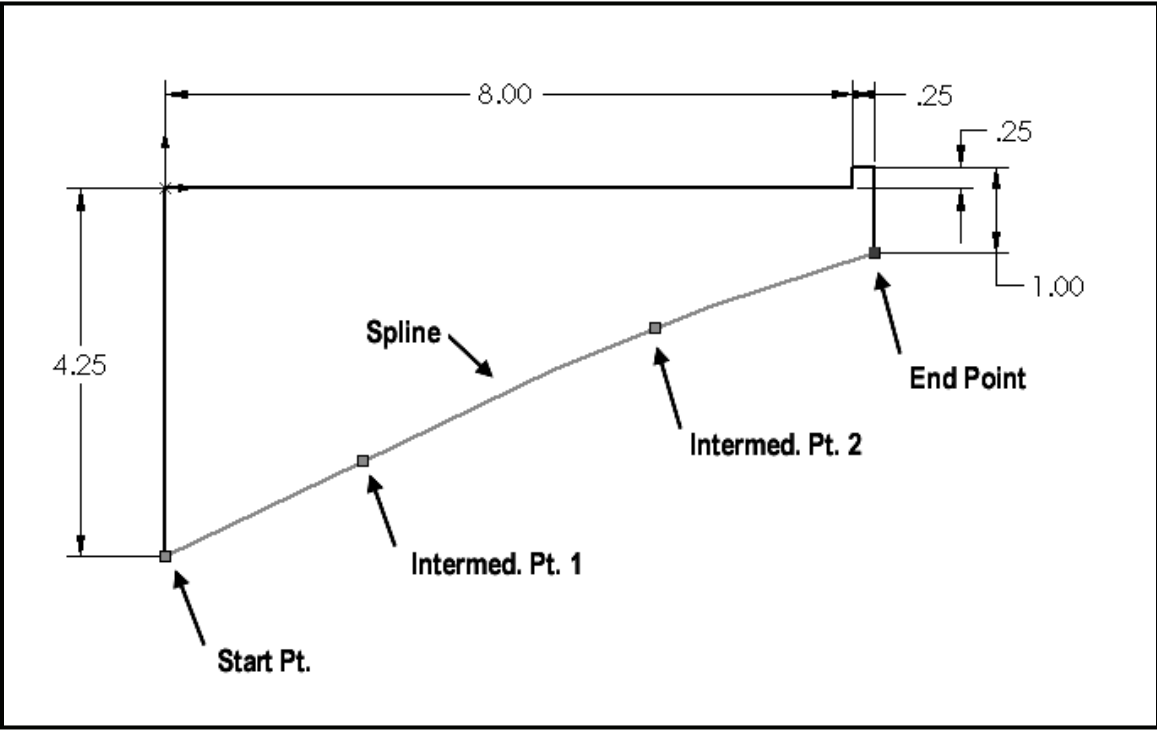

Figure 1-33. Sketching the Spline through its Four Points.

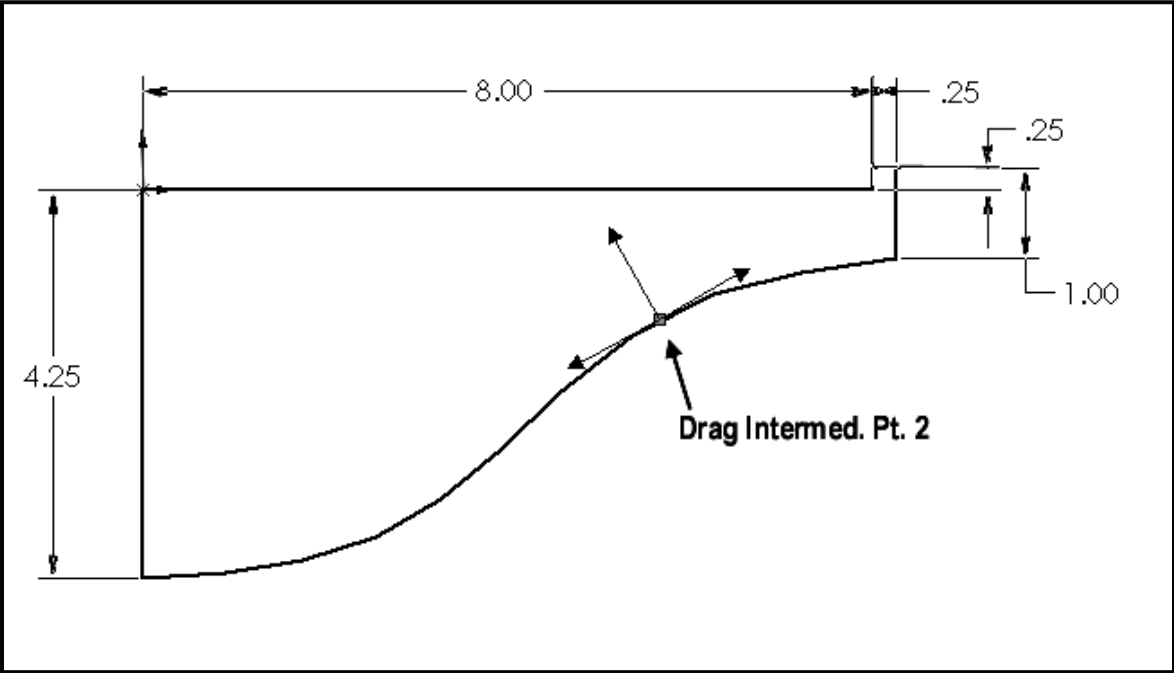

Figure 1-34. Dragging the Intermediate Points to Shape the Spline.

Now you will complete the left end of the Wall Bracket by adding the wall hooks. On the left edge, add the two wall hooks using the **Line** tool and the **Dimension** values given in **Figure 1-35**. You will have to **Trim** two places on the left edge to make the wall hooks contiguous with the rest of the profile. *Note:* The bottom wall hook has the same dimensions as the top one.

You will finish the Wall Bracket by adding a fillet to the sharp bottom corner on the right end. Since it was earlier associated with the *1.00 inch* dimension, SolidWorks will give you a warning if you try to fillet it. So it is best to just first **Delete** that dimension. Now click the **Fillet** sketch icon. Key in a radius of **0.25** inches (refer back to **Figure 1-16**). Next pick the vertical 1.00 inch right edge of the bracket and pick the spline close to its end point, and then click the green (✓) check to execute the fillet command. The 2-D profile is now complete and ready to be extruded. Pull down

Insert, Boss/Base, and Extrude. Key in a **Blind** distance of **0.125** and click the green (✓) check to complete the Wall Bracket, as shown in **Figure 1-36** in a **Trimetric** view.

If you would like to change the color of your model, click on the model name in the Feature manager tree and then select the colored ball in the menu bar. You can then assign any color you wish to the model.

Now **Save** the part as **WALL BRACKET.sldprt**. Insert the Wall Bracket onto a Title Block drawing sheet. Save as **WALL BRACKET.slddrw** and **Print** a hard copy for your instructor. See Page 1-7 for instructions.

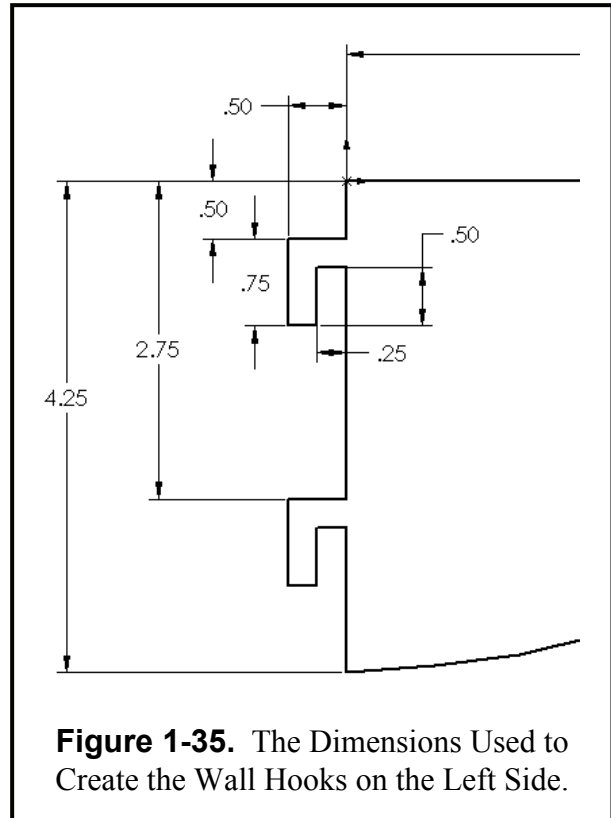

Figure 1-35. The Dimensions Used to Create the Wall Hooks on the Left Side.

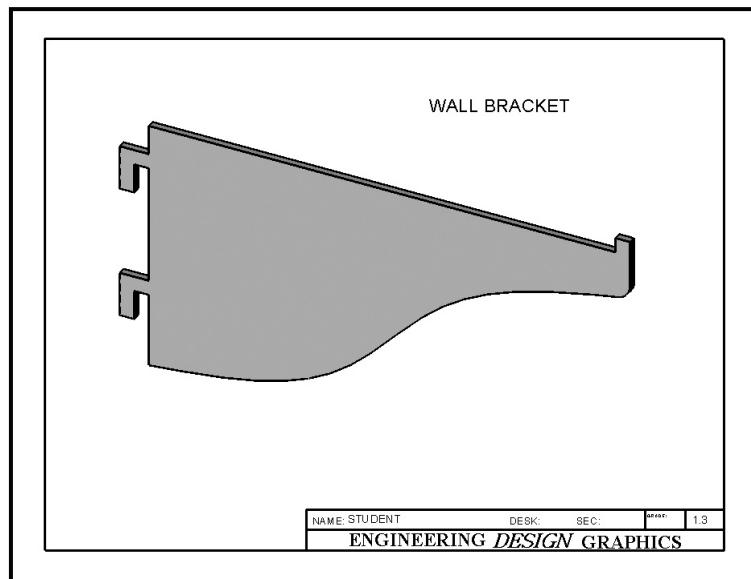

Figure 1-36. The Completed Wall Bracket in a Trimetric View.

Exercise 1.4: MACHINE HANDLE

In the previous exercises, the parts were designed using English units (inches). Metric, or System International (SI), units are also common in engineering practice. In this exercise 1.4, the Machine Handle will be designed using millimeters as the basic units (see **Figure 1-37**). In addition, because of the round symmetry of the machine handle, you will create a **Base Revolve** using the 2-D sketch rather than a base extrude.

Go to your folder and **Open** the file **ANSI-METRIC.prtdot**. In order to avoid corrupting the **ANSI-METRIC.prtdot** template go to **File – Save as:** under **File Name**, type **MACHINE HANDLE**, and under **Save as type**, Select **.sldprt** and select **SAVE**.

Next, Go to **TOOLS – OPTIONS – DOCUMENT PROPERTIES** and select “**Grid/Snap.**” Make the following settings on this menu:

“Major grid spacing” = **5 mm**

“Minor lines per major” = **0**

“Check the **Display Grid** box (√).

Also go to System Snaps and make sure “Grid” and the “Snap” functions are checked (√) on, then click the **OK** button.

Pick a **Front** plane and click the **Sketch** icon to start your sketch. The screen area should show a metric grid with spacing every 5 millimeters. You may need to **Zoom** in. Using the **Centerline**, **Line**, and **Centerpoint Arc** tools, sketch the enclosed 2-D profile shown in **Figure 1-37**.

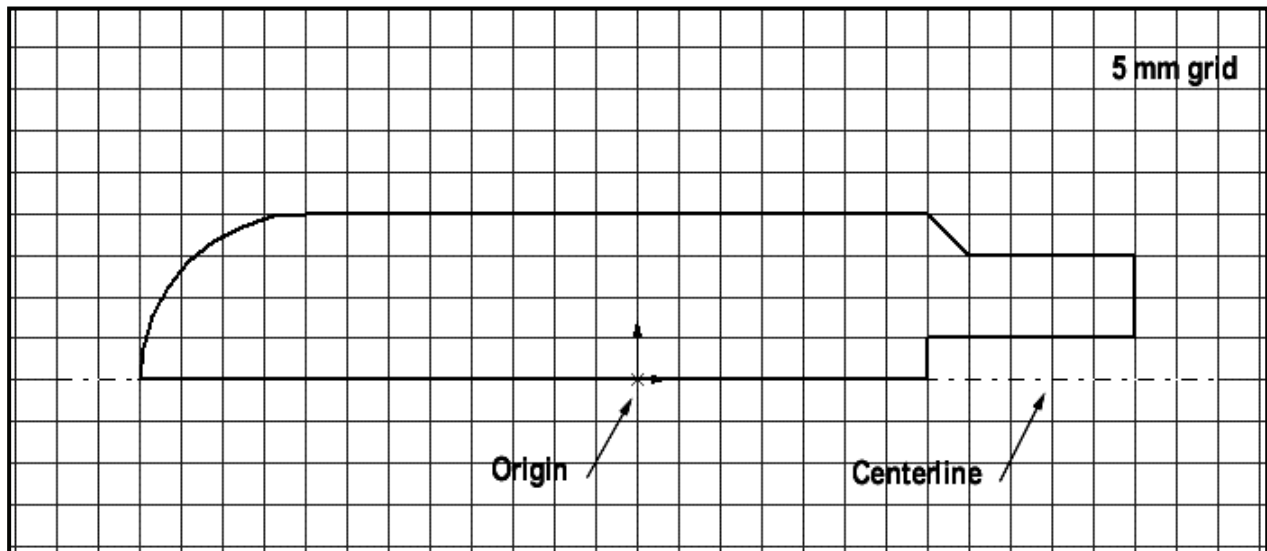

Figure 1-37. The 2-D Sketch for the Machine Handle.

Now you will revolve this simple sketch into a solid model. Go to the **Features** option and **Select** the **Revolve Base/Boss** icon. The “Base Revolve” menu appears in the Feature Manager area as shown in **Figure 1-38**. The main choice you have here is the degrees of revolution about the centerline. Set it to a full revolution of **360°** and then click the green (✓) check to close it. Your part should now appear as shown in **Figure 1-39** with an **Isometric** view.

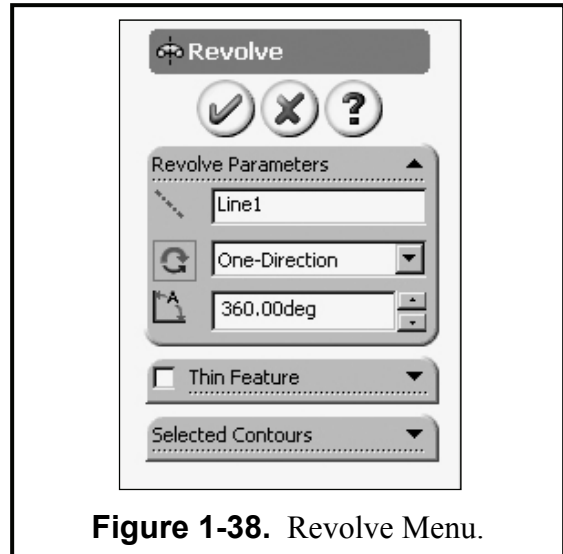

Figure 1-38. Revolve Menu.

There are many different designs for a Machine Handle, and the one here is quite typical. After studying it, however, you notice that the sharp outer edge on the right side poses a concern. SolidWorks allows you to easily fix these design changes after the solid model has been built. One way is to simply go back and edit the original sketch.

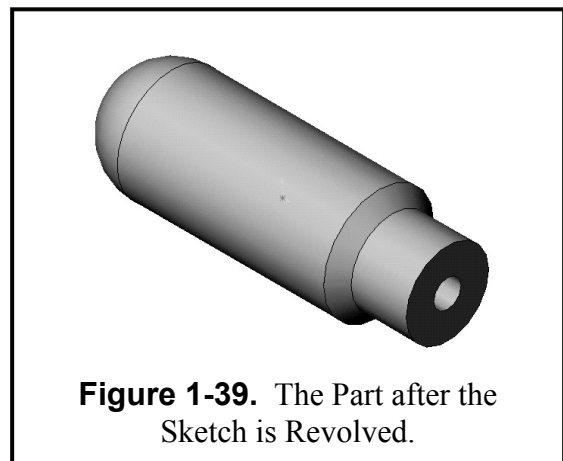

Figure 1-39. The Part after the Sketch is Revolved.

Notice in the Feature Manager that SolidWorks keeps a running tabulation of the features you used to build the part. One of them should read “Base Revolve,” which is the operation you just completed. Left of this “Base Revolve” is a plus (+) sign. Click on this (+) sign and down comes the name of “Sketch1.” Right mouse click on this Sketch1 label and a short pull-down menu appears as shown in **Figure 1-40**. Left mouse click on the **Edit Sketch** option and the sketch appears again, with grids, on the screen. Select the **Front** view orientation to better see the sketch.

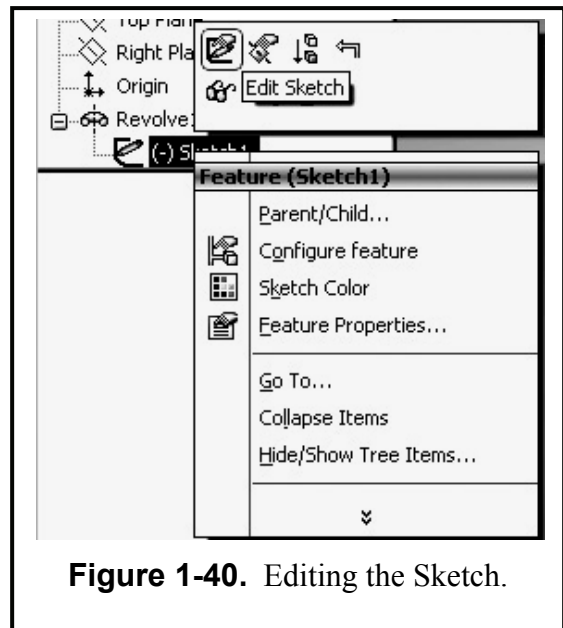

Figure 1-40. Editing the Sketch.

There are different ways to eliminate the sharp edge. One way is to use a chamfer; however you probably cannot find a chamfer icon on the sketch editing toolbars. The chamfer icon is nested with the fillet icon. An down arrow next to the fillet icon is another pull down menu and under that menu is the Chamfer icon. The “Sketch Chamfer” menu now appears. Set the “Chamfer parameters” as shown in **Figure 1-41**, including the chamfer distance of **3 mm**. Now click on the two lines that form the sharp edge corner, and then click the green (✓) check to complete this chamfer operation.

The new feature is created, but the new model is not displayed yet. You need to rebuild the model first. Pull down **Edit**, and select the **Rebuild** option (it may be in the *customize menu* section of the pull-down menu). *Note:* There is also a small icon for the rebuild command. It appears on the top toolbar and looks like a green and red traffic light. The model is rebuilt now with a chamfer, as shown in the final picture (**Figure 1-42**) in an **Isometric** view with the **Shadows in Shaded** icon clicked **on**. Now you see how easy it is to make design changes to a solid model that is already built. You just simply edit the sketch that created the model in the first place.

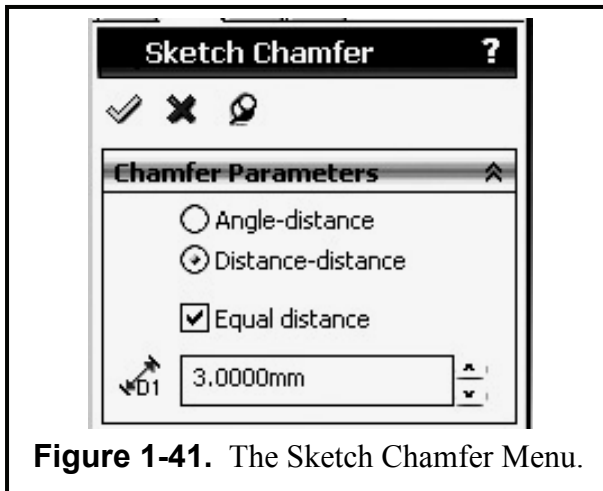

Figure 1-41. The Sketch Chamfer Menu.

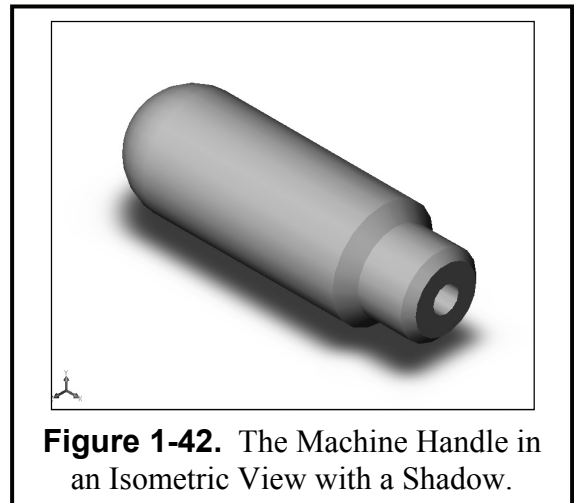

Figure 1-42. The Machine Handle in an Isometric View with a Shadow.

If you would like to change the color of your model, click on the model name in the Feature manager tree and then select the colored ball in the menu bar. You can then assign any color you wish to the model.

You should now save your model. Pull down **File**, select **Save As**, type in the part name **MACHINE HANDLE.sldprt**, and then click **Save**. Insert the rendered Machine Handle image into your **Title Block** drawing sheet, as shown in **Figure 1-43**. Add the title of the part in the open area of the drawing with a 20pt or 6mm letter height. Also add the Exercise number (**4.1**) in the upper right hand box of the Title Sheet. Now **SAVE** your drawing sheet to your directory as **MACHINE HANDLE.slddrw**.

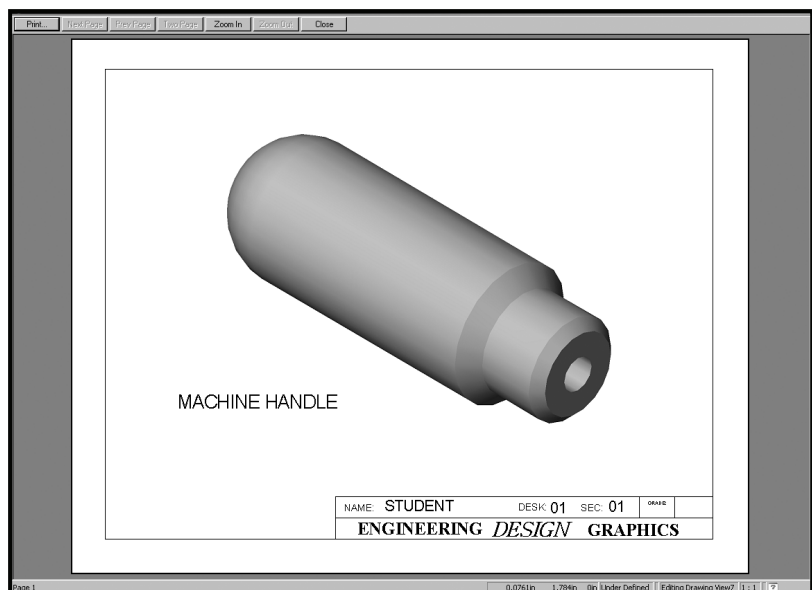
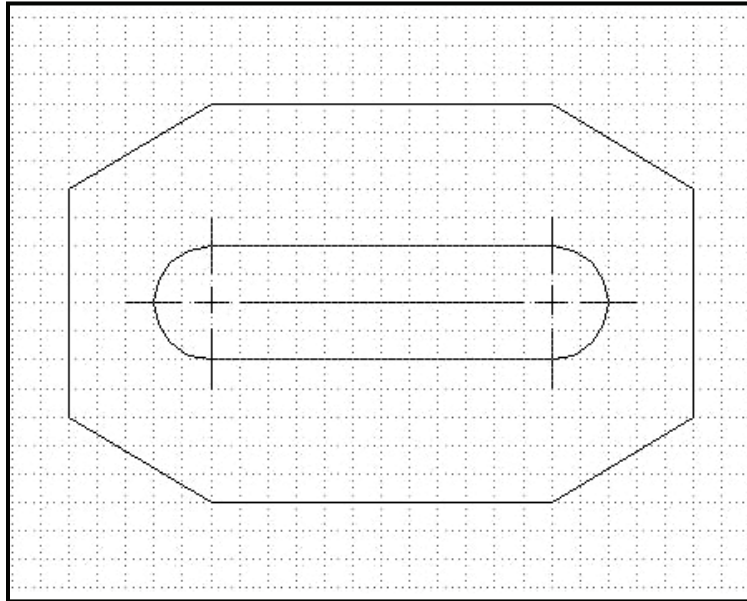

Figure 1-43. A Print Preview of the Machine Handle on the Title Block Drawing Sheet.

Supplementary Exercise 1-5: SLOTTED BASE

Make a full size sketch of the figure below in the **Top Plane** and extrude it for **0.50** inches. Insert it on a Title Block and title it “**SLOTTED BASE.**”



ASSUME THE GRID DIVISIONS TO BE 0.25 INCHES

Supplementary Exercise 1-6: TRANSITION LINK

Make a full size sketch of the figure below in the **Front Plane**. Extrude it **0.375**". Insert it onto a Title Block and title it **TRANSITION LINK.**

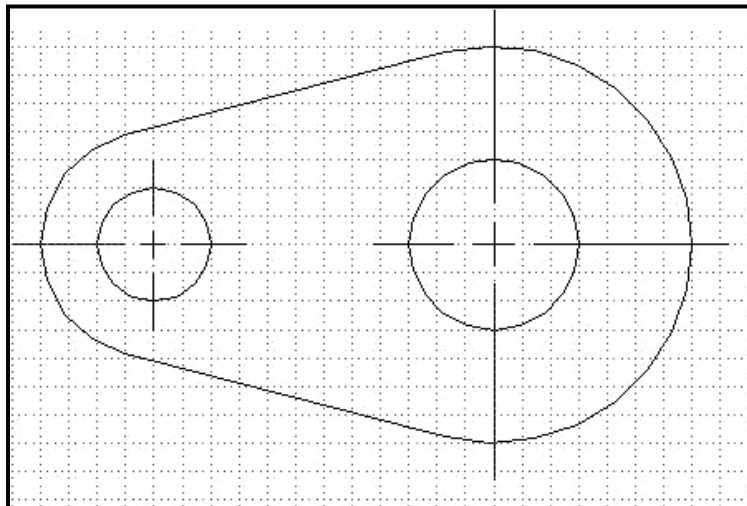

ASSUME THE GRID DIVISIONS TO BE 0.25 INCHES

Supplementary Exercise 1-7: TEE BRACKET

Make a full size sketch of the figure below in the **Top Plane** and extrude it to the height indicated. Insert it on a Title Block and title it “**TEE BRACKET.**”

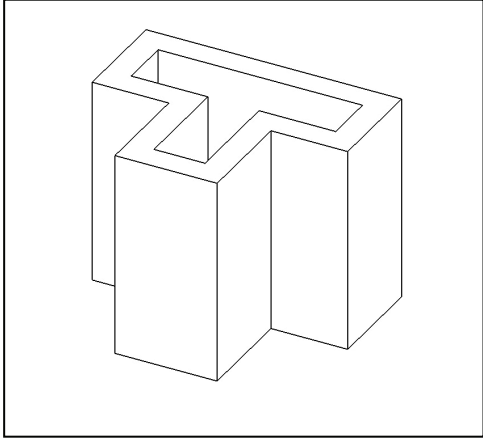
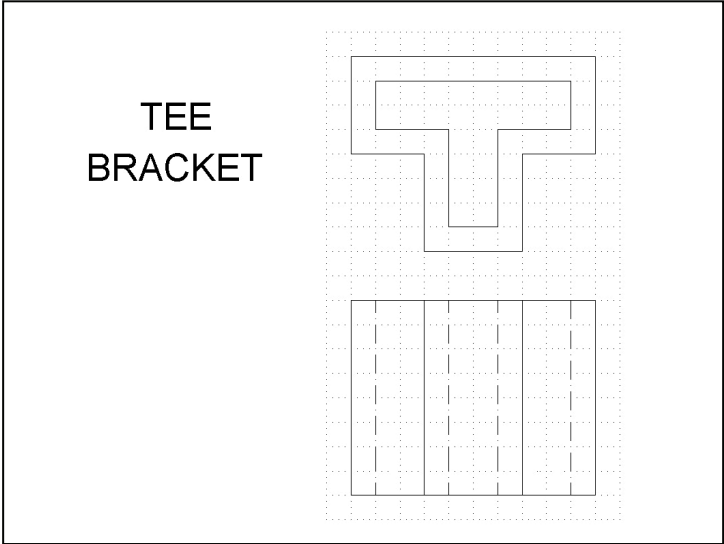

PICTORIAL OF THE TEE BRACKET

ASSUME THE GRID DIVISIONS TO BE 5 MM

Supplementary Exercise 1-8: CABLE SPOOL

Make a full size sketch of the **PROFILE** below in the **Front Plane** and do an **INSERT – BASE – REVOLVE**. Insert it on a Title Block and title it “**CABLE SPOOL.**”

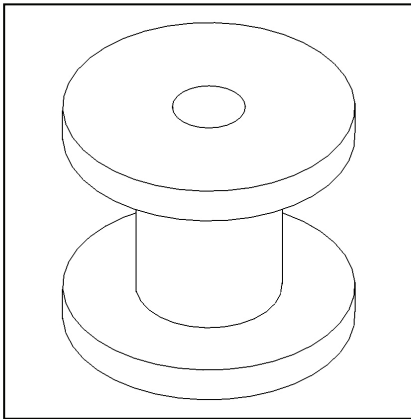
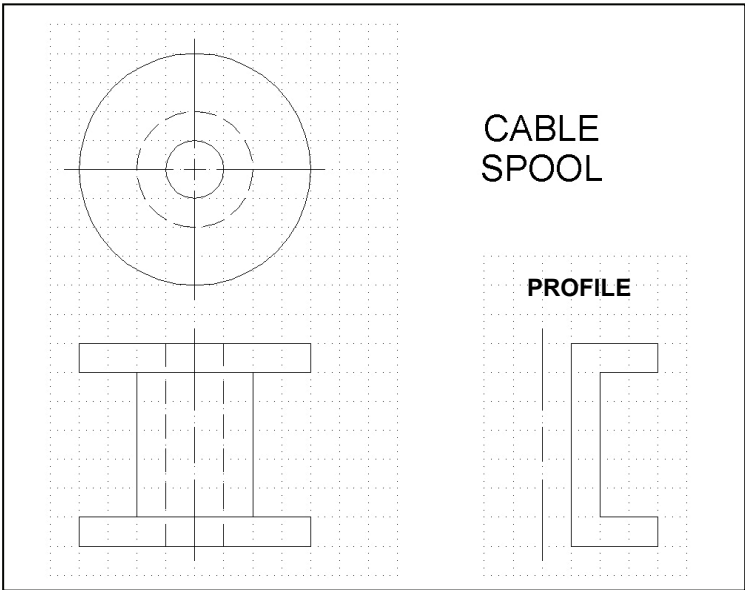

PICTORIAL OF THE CABLE SPOOL

ASSUME THE GRID DIVISIONS TO BE 1.00 INCH