

CATIA V5

FEA Tutorials

Release 19

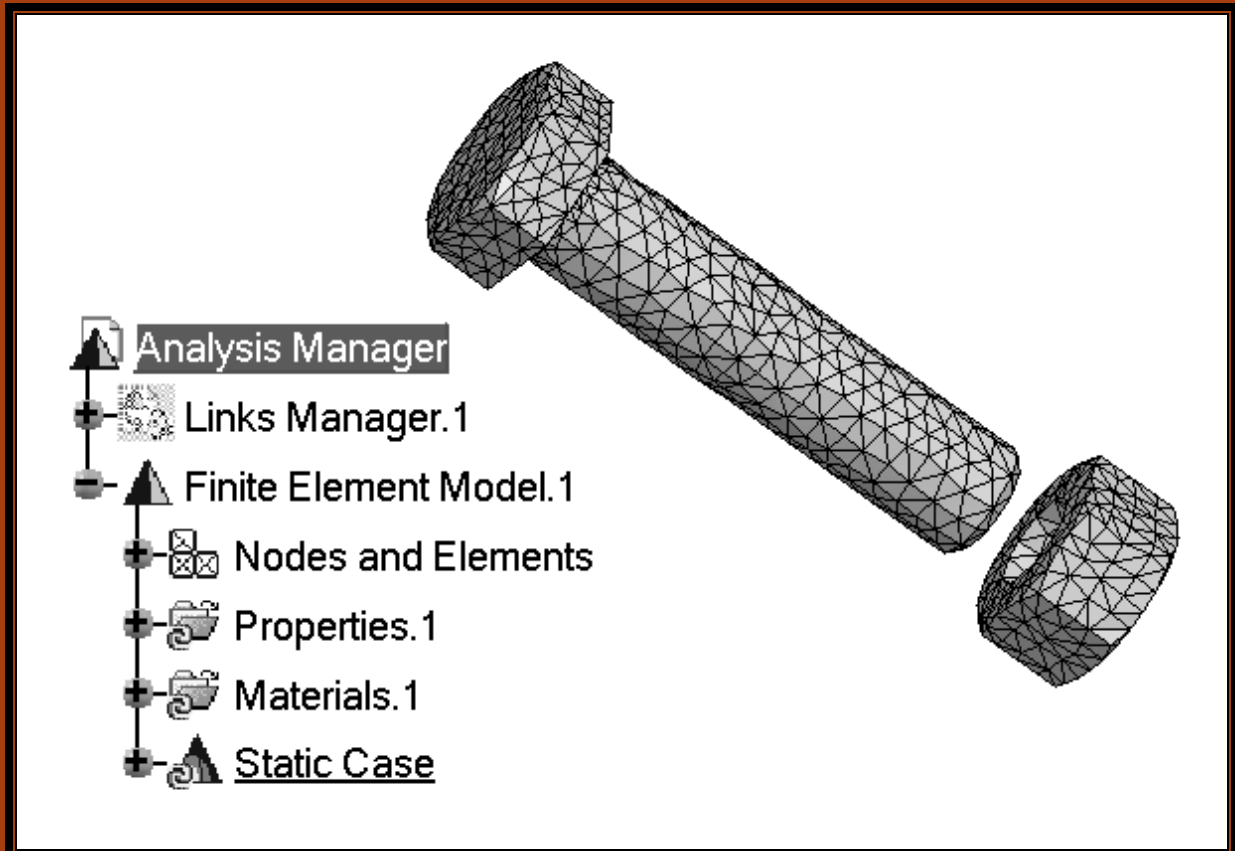

Nader G. Zamani

University of Windsor

SDC
PUBLICATIONS

Schroff Development Corporation
www.schroff.com

Better Textbooks. Lower Prices.

Chapter 2

Analysis of a Bent Rod with Solid Elements

Introduction

In this tutorial, a solid FEA model of a bent rod experiencing a combined load is created. No planes of symmetry exist and therefore model simplifications cannot be made. Finally, the significance of the von Mises stress in design equation is discussed.

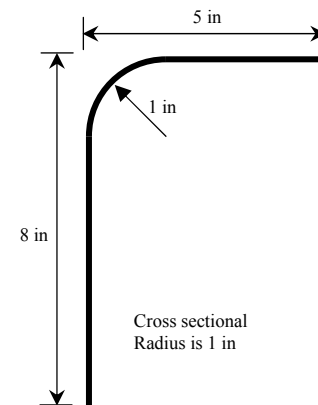
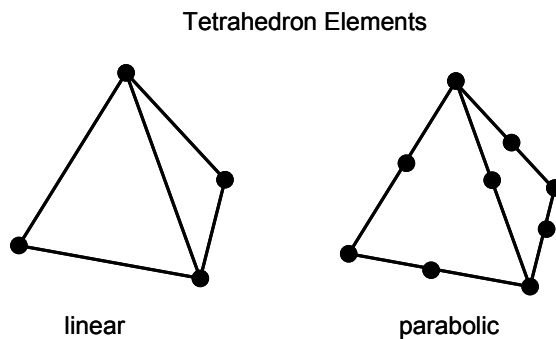
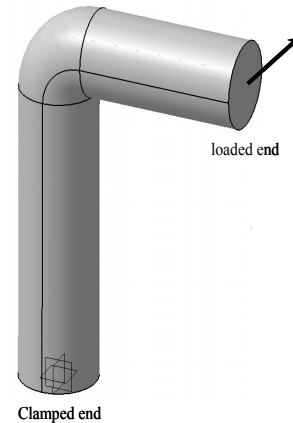

1 Problem Statement

The bent rod, shown to the right, is clamped at one end and subjected to a load of 2000 lb as displayed. The steel rod has a Young's modulus of $30E+6$ psi and Poisson ratio 0.3. The nominal dimensions of the rod are also displayed below. Although this problem is more efficiently handled with beam elements, we propose to use solid elements. There are two main types of solid elements available in CATIA V5, linear and parabolic. Both are referred to as tetrahedron elements and shown below.



The linear tetrahedron elements are faster computationally but less accurate. On the other hand, the parabolic elements require more computational resources but lead to more accurate results. Another important feature of parabolic elements is that they can fit curved surfaces better. In general, the analysis of bulky objects requires the use of solid elements. Hexahedral elements are also available on a limited basis in recent releases of CATIA. These elements will be discussed in a later chapter.

2 Creation of the Part in Mechanical Design Solutions

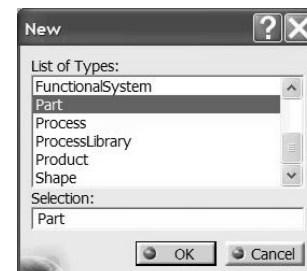

Enter the **Part Design** workbench  which can be achieved by different means depending on your CATIA customization. For example, from the standard Windows toolbar, select **File > New** . From the box shown on the right, select **Part**. This moves you to the **Part Design** workbench and creates a part with the default name **Part.1**. See Note#1 in Appendix I.



In order to change the default name, move the cursor to **Part.1** in the tree, right-click and select **Properties** from the menu list.

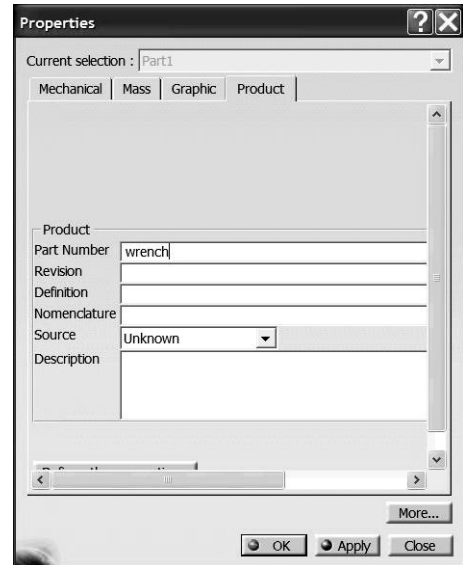
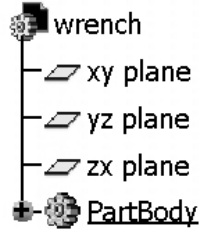

From the **Properties** box, select the **Product** tab and in **Part Number** type **wrench**. This will be the new part name throughout the chapter. The tree on the top left corner of the screen should look as displayed below.



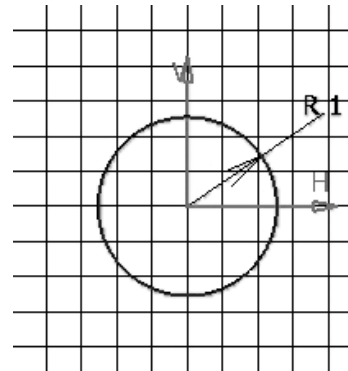
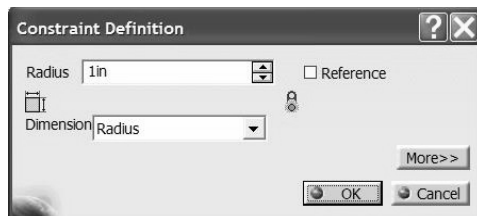

From the tree, select the **xy** plane and enter the **Sketcher** . In the **Sketcher**, draw a circle , and dimension it . In order to change the dimension, double-click on the dimension on the screen and in the resulting box enter radius 1. Your simple sketch and the **Constraint Definition** box used to enter the correct radius are shown below.

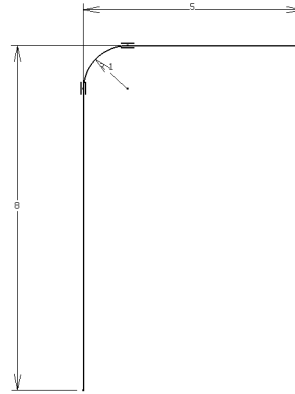
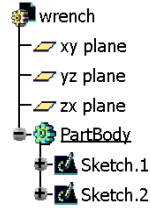
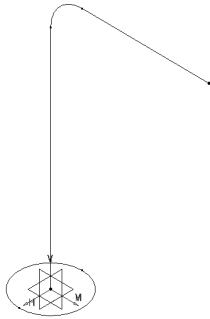

Leave the **Sketcher** .

From the tree, select the **yz** plane and enter the **Sketcher** . Draw the spine of the bent rod by using **Profile**  and dimension it to meet the geometric specs. In the **Sketcher**, the spine should match the figure shown next. Upon leaving the **Sketcher** , the screen and the tree should resemble the following figures.



You will now use the ribbing operation to extrude the circle along the spine (path). Upon selecting the rib icon , the **Rib Definition** box opens. For **Profile** select the circle (**Sketch.1**) and for the **Center Curve** select (**Sketch.2**) as indicated. The result is the final part shown below.

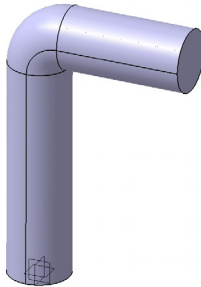

The next step is to apply material properties on the part created.

Use the **Apply Material** icon  from the bottom row of toolbars. The use of this icon opens the material database box shown next.

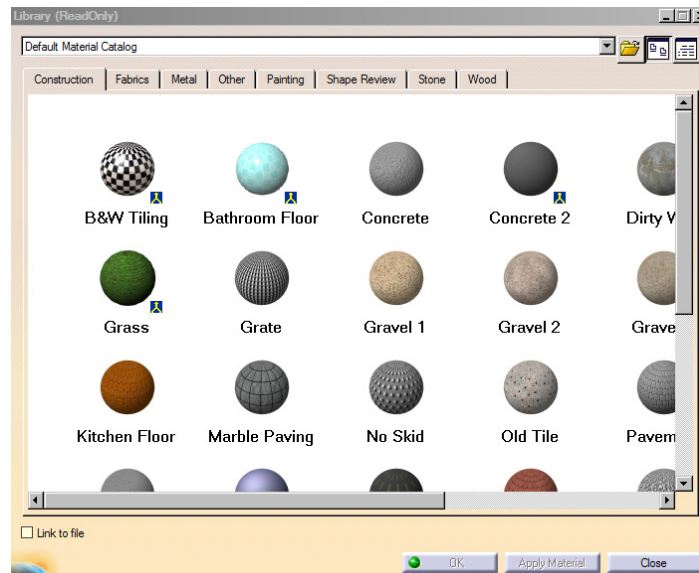

Choose the **Metal** tab on the top; select **Steel**. Use your cursor to pick the part on the screen at which time the **OK** and **Apply Material** buttons can be selected.
Close the box.

The material property is now reflected in the tree.

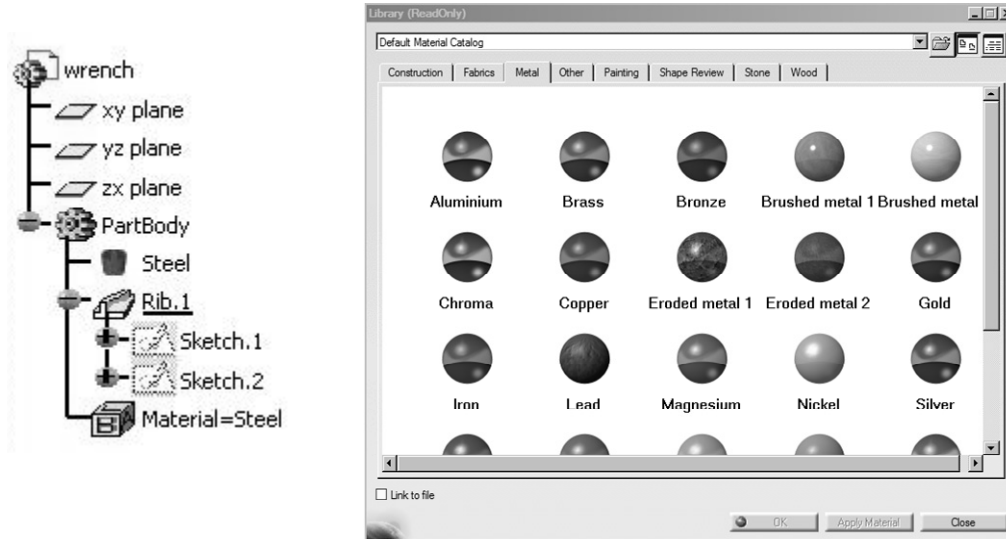

In order to inspect the values of the material properties assigned, double-click on **Steel** in the tree. It may take a minute before the database is searched. You will notice that the **Properties** box shown below opens. Choose the **Analysis** tab from this box, and the values will be displayed. Note that these values can be edited.

Since your Young's modulus and Poisson ratio are different from what is shown, in appropriate boxes, type Young's modulus = $3E+7$ and Poisson ratio = $.3$. Press **OK**.

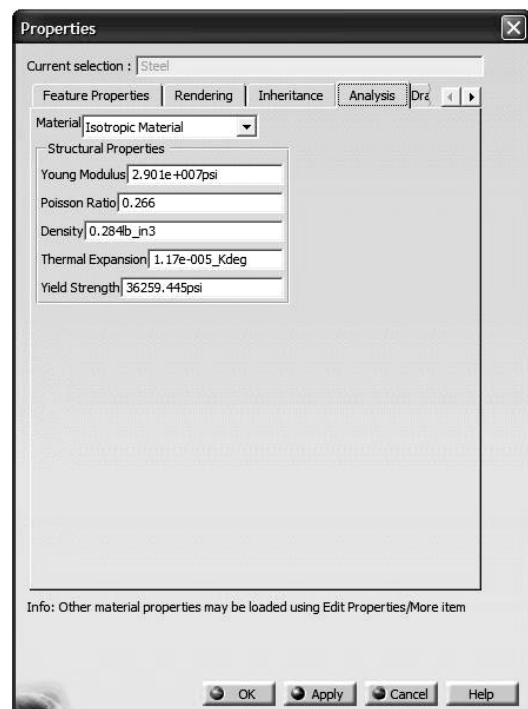
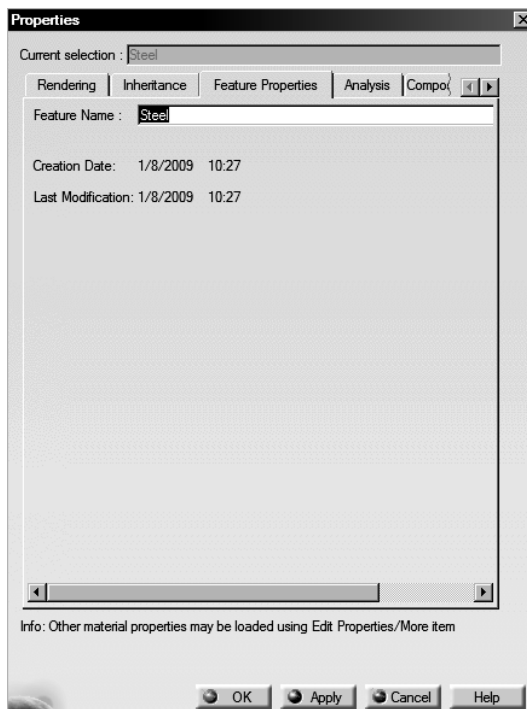

If the part is still “gray”, one can change the rendering style. From the **View** toolbar



, select the **View mode** toolbar



Next choose the **Shading with Material** 

The part now appears shaded as shown on the right.



3 Entering the Analysis Solutions

From the standard Windows toolbar, select

Start > Analysis & Simulation > Generative Structural Analysis 

There is a second workbench known as the **Advanced Meshing Tools** which will be discussed later.

The **New Analysis Case** box pops up. The default choice is **Static Analysis** which is precisely what we intend to use. Therefore, close the box by clicking on **OK**.

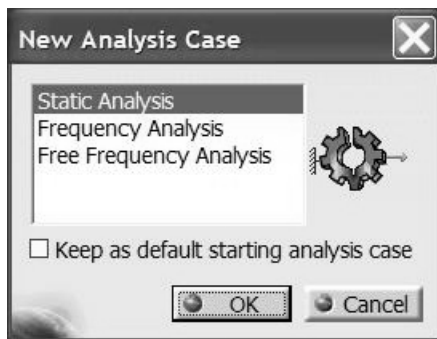

Note that the tree structure gets considerably longer. The bottom branches of the tree are presently “unfilled”, and as we proceed in this workbench, assign loads and restraints, the branches gradually get “filled”.

Another point that cannot be missed is the appearance of an icon close to the part that reflects a representative “size” and “sag”. This is displayed in the next figure.

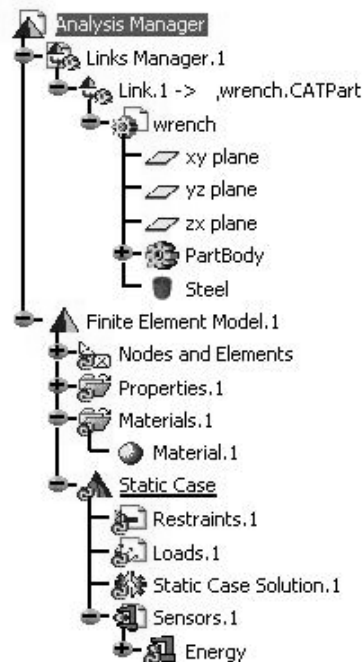

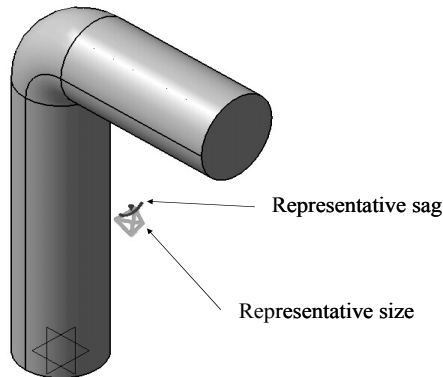

The concept of element size is self-explanatory. A smaller element size leads to more accurate results at the expense of a larger computation time. The “sag” terminology is unique to CATIA. In FEA, the geometry of a part is approximated with the elements. The surface of the part and the FEA approximation of a part do not coincide. The “sag” parameter controls the deviation between the two. Therefore, a smaller “sag” value could lead to better results. There is a relationship between these parameters that one does not have to be concerned with at this point.

The physical sizes of the representative “size” and “sag” on the screen, which also limit the coarseness of the mesh can be changed by the user. There are two ways to change these parameters:

The first method is to double-click on the representative icons on the screen which forces the **OCTREE Tetrahedron Mesh** box to open as shown to the right. Change the default values to match the numbers in the box.

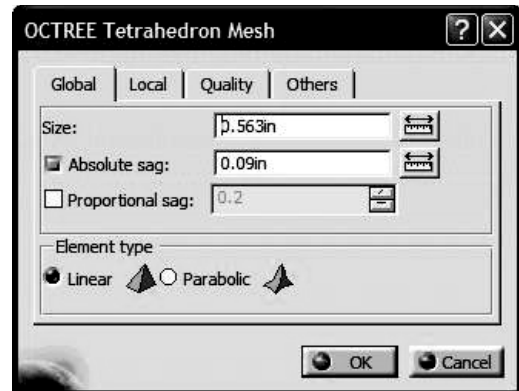

Notice that the type of the elements used (linear/parabolic) is also set in this box. Close the box by selecting **OK**.

The second method of reaching this box is through the tree.

By double-clicking on the branch labeled **OCTREE Tetrahedron Mesh** shown below, the same box opens allowing the user to modify the values.

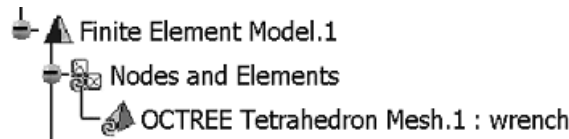

In order to view the generated mesh, you can point the cursor to the branch **Nodes and Elements**, right-click and select **Mesh Visualization**. This step may be slightly different in some UNIX machines. Upon performing this operation a **Warning** box appears which can be ignored by selecting **OK**. For the mesh parameters used, the following mesh is displayed on the screen. See Note #2 in Appendix I.

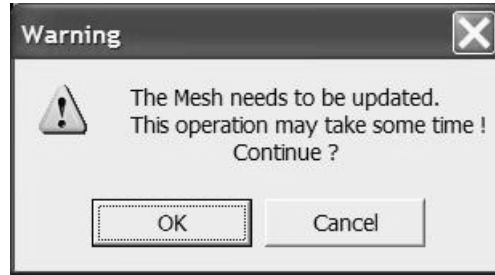
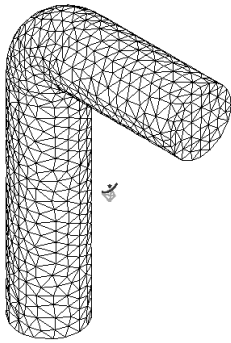

The representative “size” and “sag” icons can be removed from the display by simply pointing to them right-click and select **Hide**. This is the standard process for hiding any entity in CATIA V5.

Before proceeding with the rest of the model, a few more points regarding the mesh size are discussed. As indicated earlier, a smaller mesh could result in a more accurate solution; however, this cannot be done indiscriminately. The elements must be small in the regions of high stress gradient such as stress concentrations. These are areas where the geometry changes rapidly such as bends, fillets, and keyways. Uniformly reducing the element size for the whole part is a poor strategy.

CONGRATULATIONS! You now have a mesh with the correct material properties. Regularly save your work.

Applying Restraints:

CATIA’s FEA module is geometrically based. This means that the boundary conditions cannot be applied to nodes and elements. The boundary conditions can only be applied at the part level. As soon as you enter the **Generative Structural Analysis** workbench, the part is automatically hidden.

Therefore, before boundary conditions are applied, the part must be brought to the unhide mode. This can be carried out by pointing the cursor to the top of the tree, the **Links Manager.1** branch, right-click, select **Show**. At this point, the part and the mesh are superimposed as shown to the right and you have access to the part.

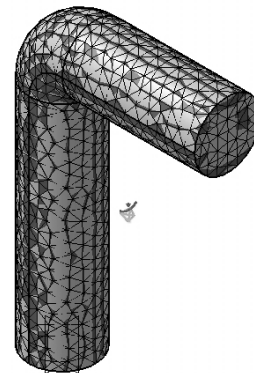

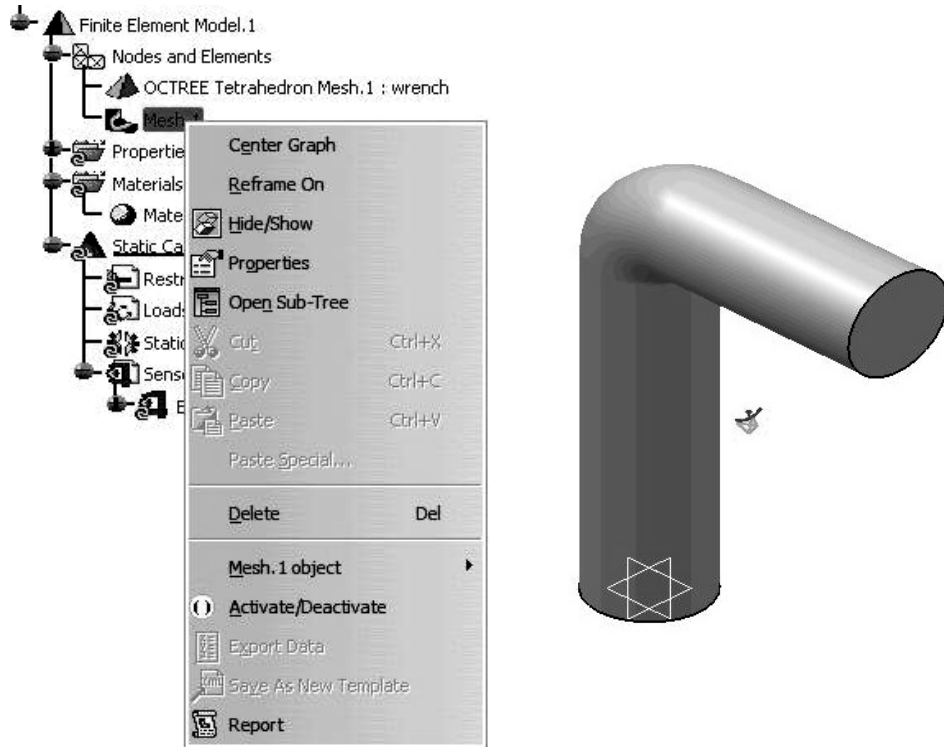

If, the presence of the mesh is annoying, you can always hide it. Point the cursor to **Nodes and Elements**, right-click, **Hide**.

Instead of hiding the mesh as indicated above, one can point the cursor to the **Mesh.1** item in the tree, right-click, and select **Activate/Deactivate**. The result is that the mesh is hidden and the part is displayed. The steps are graphically in the next figure.



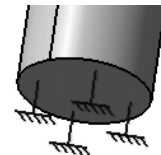

In FEA, restraints refer to applying displacement boundary conditions which is achieved

through the **Restraint** toolbar . In the present problem, you can assume that the base of the longer section is clamped. The **Clamp** condition means that the displacements in all three directions are zero. Select the **Clamp** icon  and pick the bottom face of the rod. Be careful not to pick the circumference (edge) of the circle instead of the face. In that case, only two restraint symbols will be shown attached to the circumference.



Applying Loads:

In FEA, loads refer to forces. The **Loads** toolbar  is used for this purpose. Select the **Distributed Force** icon , and with the cursor pick the other face of the rod which is loaded. The **Distributed Force** box shown below opens. A visual inspection of the global axis on your screen indicates that the force of magnitude 2000 lb should be applied in the negative x-direction.

Although in our problem the 2000 lb force is applied in the global direction x, it is possible to apply forces in the local direction specified by the user. Upon selection of the appropriate face, the force symbols will appear as shown below.

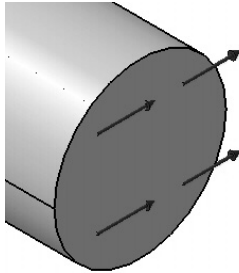

If the circumference of the circle is accidentally picked, only two arrows attached to the circle will appear. Although in our present problem there may be small differences in the results, one should apply the loads and restraints as intended.

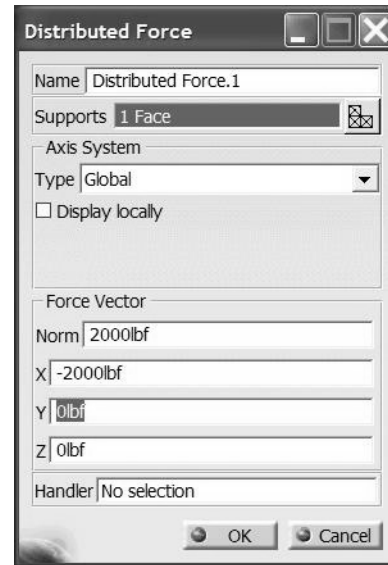

The portion of the tree which reports the restraints and loads is shown below.

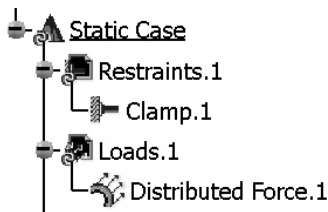

Launching the Solver:

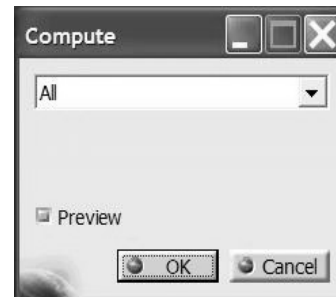

To run the analysis, you need to use the **Compute**



toolbar by selecting the **Compute** icon . This leads to the **Compute** box shown above. Leave the defaults as **All** which means everything is computed.

Upon closing this box, after a brief pause, the second box shown below appears. This box provides information on the resources needed to complete the analysis.

If the estimates are zero in the listing, then there is a problem in the previous step and should be looked into. If all the numbers are zero in the box, the program may run but would not produce any useful results.

The tree has been changed to reflect the location of the Results and Computations as shown below.

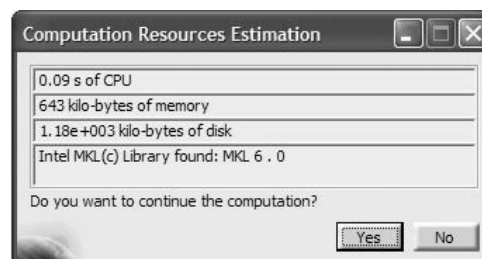

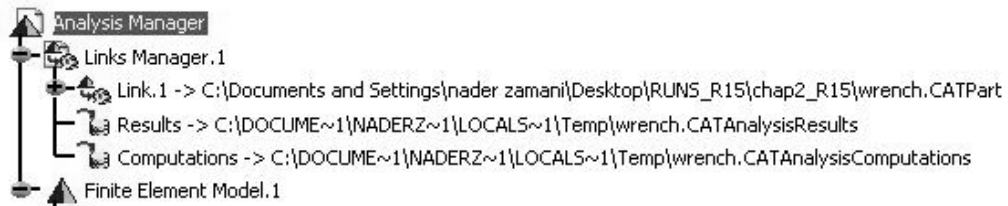

The user can change these locations by double-clicking on the branch. The box, shown on the right, will open and can be modified.

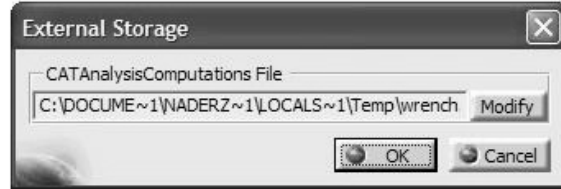

Postprocessing:

The main postprocessing toolbar is called **Image**. To view the deformed shape you have to use the **Deformation** icon. The resulting deformed shape is displayed below.

The deformation image can be very deceiving because one could have the impression that the wrench actually displaces to that extent. Keep in mind that the displacements are scaled considerably so that one can observe the deformed shape.

Although the scale factor is set automatically, one can change this value with the **Deformation Scale Factor** icon in the

Analysis Tools toolbar

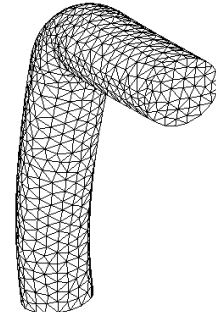

Clicking on the above icon leads to the box shown on the right where the desired scale factor can be typed. The deformed shape displayed corresponds to a scale factor of 46.017. The displayed value on the screen is 46.017 times the actual maximum displacement.



In order to see the displacement field, the

Displacement icon  in the **Image** toolbar should be used. The default display is in terms of displacement arrows as shown on the right. The color and the length of arrows represent the size of the displacement. The contour legend indicates a maximum displacement of .0353 in.

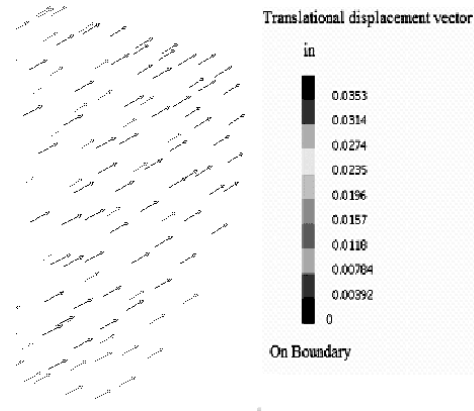

The arrow plot is not particularly useful. In order to view the contour plot of the displacement field, position the cursor on the arrow field and double-click. The **Image Edition** box shown below opens.

Note that the default is to draw the contour on the deformed shape. If this is not desired, uncheck the box **On deformed mesh**. Next, select **AVERAGE-ISO** and press **OK**. The contour of the displacement field as shown is plotted.

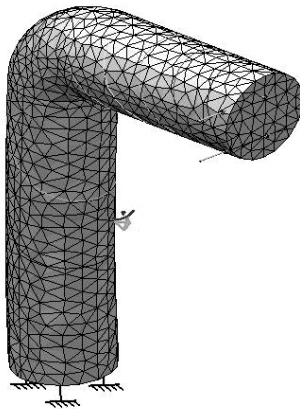

It is difficult to read the contour lines from the above figure. You can change the render style by using

Shading with Material  icon in the **View Mode** toolbar



Note that the elements are not showing in this plot. If you prefer that the elements are displayed at the same time, you need to go through the following step.

Select the **Custom View Mode** icon  from the above toolbar. In the resulting pop up box, make sure that **Edges and points** is checked.

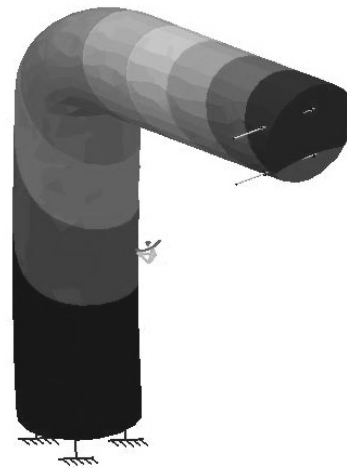

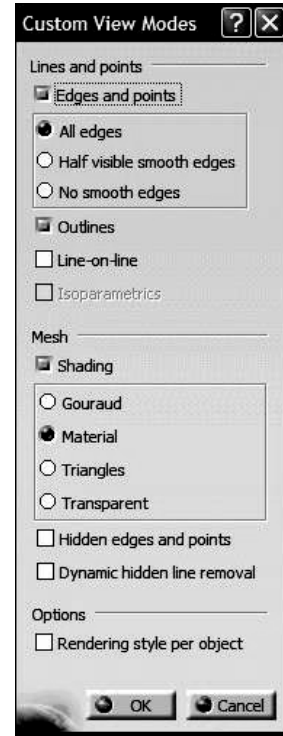
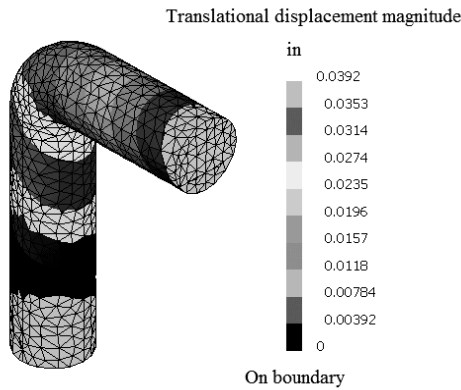

Ignoring the fillet radius of the bend, the beam bending solution of this problem can be obtained using Castigliano’s theorem. This approximate value is .044 in which is in the same ball park as the FEA solution of .0392 in. The discrepancy is primarily due to the large bend radius.

Clearly, the maximum displacement is at the point of the application of the load, in the negative x-direction. (Note: The color map has been changed; otherwise everything looks black in the figure.)

The next step in the postprocessing is to plot the contours of the von Mises stress using the **von Mises Stress** icon  in the **Image** toolbar. The von Mises stress is displayed to the right.

The maximum stress is at the support with a value of 2.06E+4 psi which is below the yield strength of most steels.

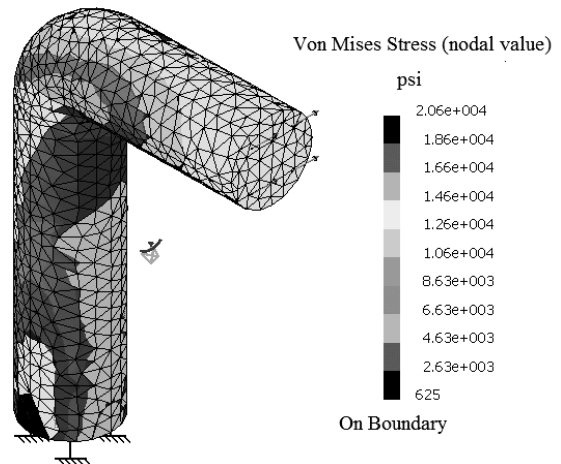

Double-clicking on the contour legend leads to the **Color Map** box displayed on the right.

The contour can be plotted as **Smooth** or **Stepped**. The number of color bands is also specified in this box. Finally, the user can describe the range of stresses to be plotted.

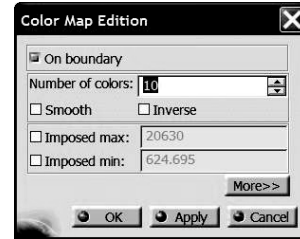

Occasionally, you may be interested in plotting the von Mises stress contour in either the load area or the support section. In order to achieve this, double-click on the contour levels on the screen to open the image edition box. Next use the **Selections** tab as shown below. Here, you have the choice of selecting different areas.

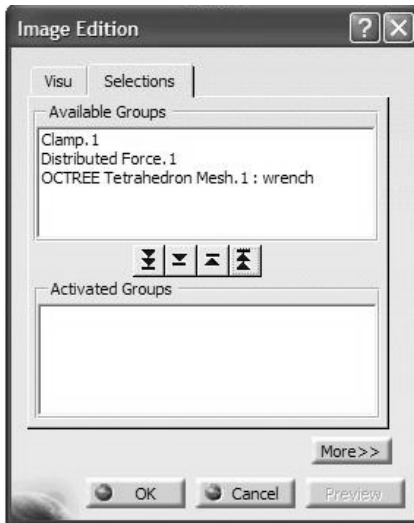

The contours on the right display the von Mises stress at **Distributed Force.1** and **Clamp.1** sections.

Unfortunately in the current release of CATIA this contour is rather useless. In a later chapter, you will be shown how to use the **Group** concept to generate a better contour plot as indicated below.

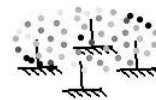
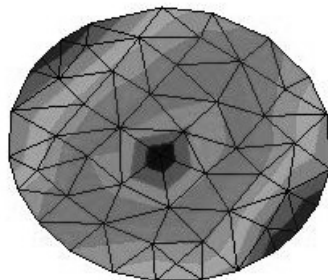
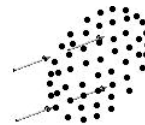

As the postprocessing proceeds and we generate different plots, they are recorded in the tree as shown. Each plot generated deactivates the previous one on the screen. By pointing to a desired plot in the tree and right-clicking, you can activate the plot. Clearly any plot can be deleted from the tree in the usual way (right-click, **Delete**).

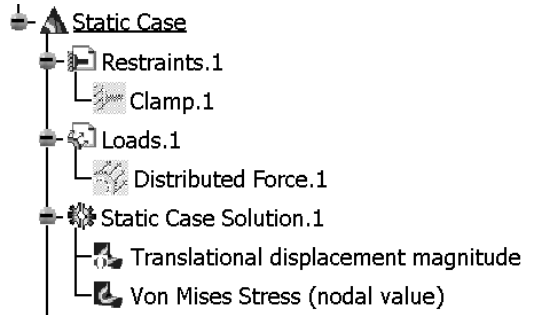

The location and magnitude of the extremum values of a contour (e.g. von Mises stress) can be identified in a plot. This is achieved by using the **Image Extrema** icon  in the



Image Analysis toolbar

Before the plot is generated, the **Extrema Creation** box pops up as shown to the right. If the default values are maintained, the global maximum and minimum are found and their location pin-pointed in a contour plot as displayed below.

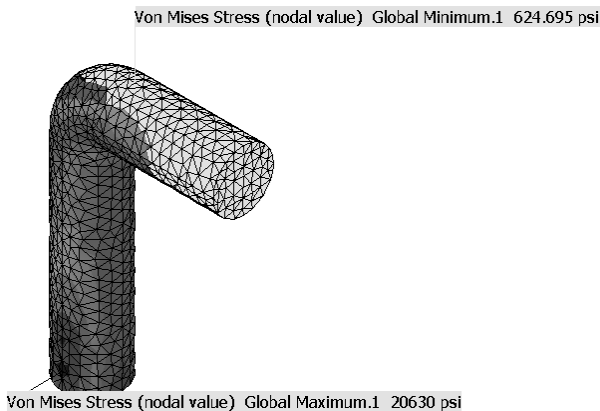
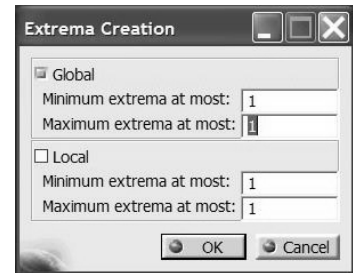

At this point we have generated two plots. The displacement and the von Mises stress contours which can be displayed individually. However, CATIA also allows you to show both plots side by side.

First make sure that both images to be plotted are active in the tree. If not, point to the graph in the tree, right-click, select **Active**.

Click the **Image Layout** icon  from the **Image Analysis** toolbar. The **Images** box, shown to the right, asks you to specify the direction along which the two plots are expected to be aligned.

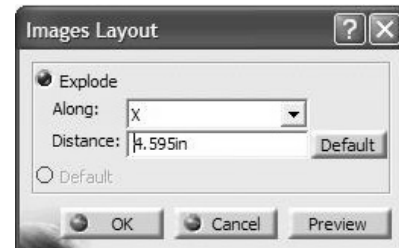

The outcome is side-by-side plots shown below. (Note: The color map has been changed otherwise everything looks black.)

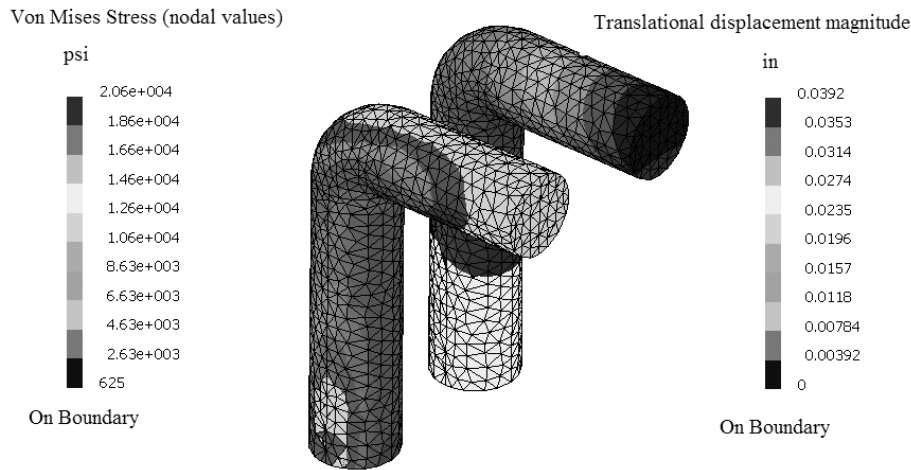

Before describing how the principal stresses are plotted, we like to elaborate on the significance of the von Mises stress plot.

The state of stress is described by the six Cauchy stresses $\{\sigma_x, \sigma_y, \sigma_z, \tau_{xy}, \tau_{xz}, \tau_{yz}\}$ which vary from point to point. The von Mises stress is a combination of these according to the following expression:

$$\sigma_{VM} = \sqrt{\frac{1}{2} [(\sigma_x - \sigma_y)^2 + (\sigma_x - \sigma_z)^2 + (\sigma_y - \sigma_z)^2 + 6(\tau_{xy}^2 + \tau_{xz}^2 + \tau_{yz}^2)]}$$

For an obvious reason, this is also known as the effective stress. Note that by definition, the von Mises is always a positive number. In terms of principal stresses, σ_{VM} can also be written as

$$\sigma_{VM} = \sqrt{\frac{1}{2} [(\sigma_1 - \sigma_2)^2 + (\sigma_1 - \sigma_3)^2 + (\sigma_2 - \sigma_3)^2]}$$

For many ductile materials, the onset of yielding (permanent plastic deformation) takes place when $\sigma_{VM} = \sigma_Y$ where σ_Y is the yield strength of the material. For design purposes, a factor of safety “N” is introduced leading to the condition $\sigma_{VM} = \frac{\sigma_Y}{N}$.

Therefore, a safe design is considered to be one where $\sigma_{VM} < \frac{\sigma_Y}{N}$. The von Mises stress contour plot allows you to check the above condition.

The **Cutting Plane** icon  from the **Analysis tools** toolbar



can be used to make a cut through the part at a desired location and inspect the stresses inside of the part. The **Cut Plane** box allows you to keep the plane or to remove it for display purposes. A typical cutting plane is shown below.

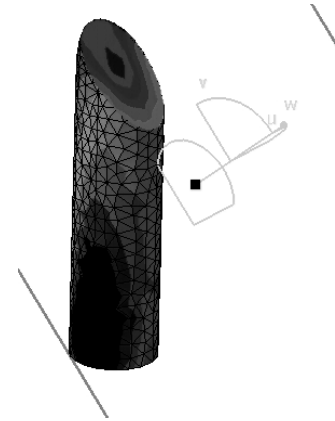

The principal stresses are postprocessed next. The principal directions are three mutually perpendicular directions along which only normal stresses act. These normal stresses are known as the principal stresses. The figure to the right displays the principal directions x_1 , x_2 , and x_3 , together with the principal directions σ_1 , σ_2 , and σ_3 . The standard convention in stress analysis is to label the stresses according to $\sigma_1 \geq \sigma_2 \geq \sigma_3$. The principal stresses are important for both theoretical reasons and practical ones. In experimental stress analysis, the positioning of strain gauges relies on the principal directions on the surface of a part.

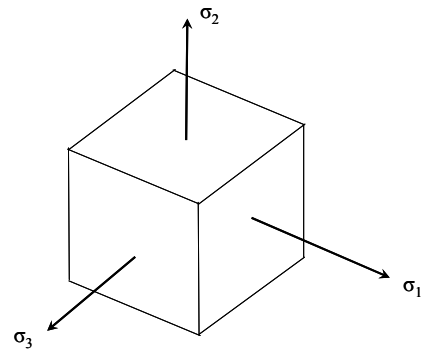

From the **Image** toolbar

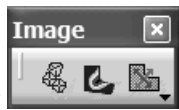

select the **Principal Stress** icon . The result is the principal stress directions in the vector form as displayed to the right. Due to the large number of arrows, the interpretation of this plot is difficult. A zoomed view of the tip is also shown below.

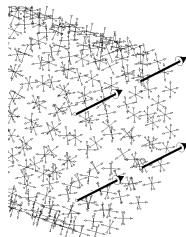
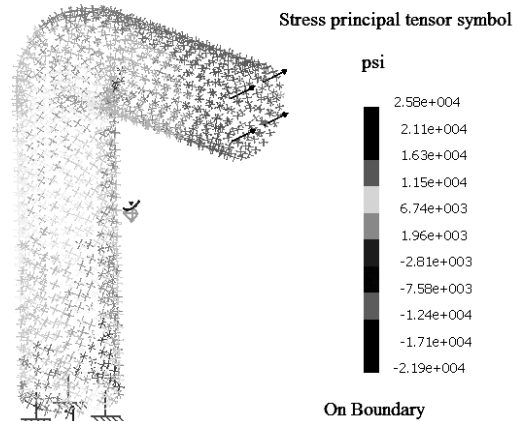

You can improve on the display of principal stresses by selecting a specific stress component to be plotted. To do so, double-click on the arrows on the screen which causes the **Image Edition**, shown to the right to open. Click on the **More** button to expand the window as shown below. Choose the **Component C11**. In CATIA, C11 represents σ_1 , the largest principal stress.

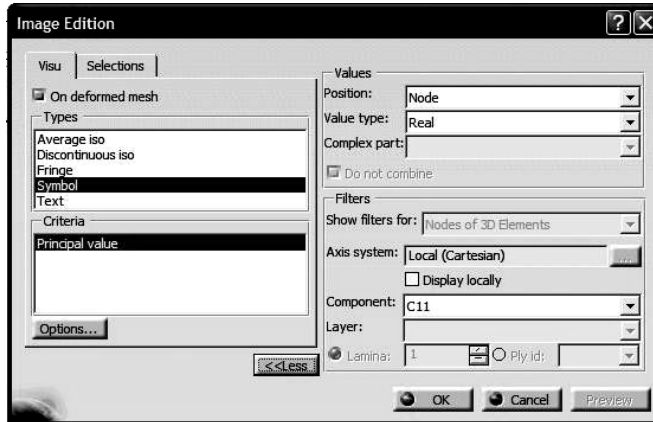
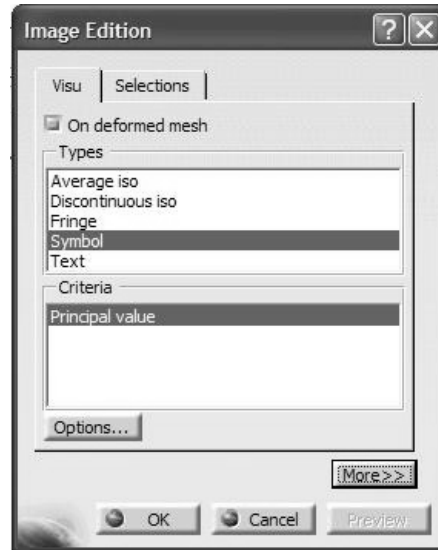

At this point the vector plot displays only the directions associated with σ_1 as shown in the plot below.

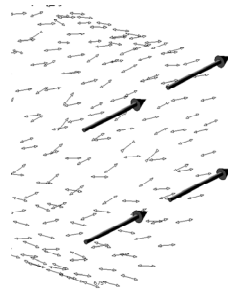

An alternative to the vector plot of the principal stress is the contour plot of σ_1 . This can be achieved through the **Image Edition** box, under the **Visu** tab. You should select **AVERAGE-ISO** instead of **Symbol**. The resulting contour plot is shown below.

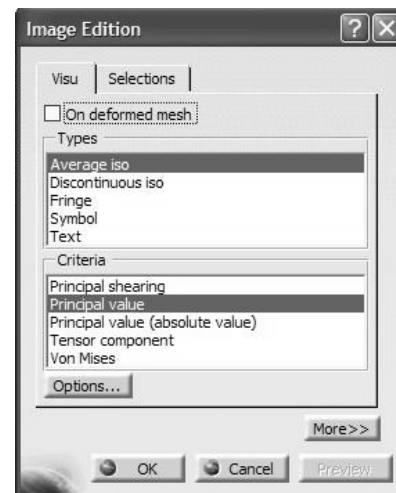
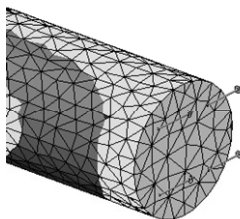

Using the icon **Generate Report**  in the **Analysis Results** toolbar



an HTML based report can be generated which summarizes the features and results of the FEA model. The first page of this report is displayed below.

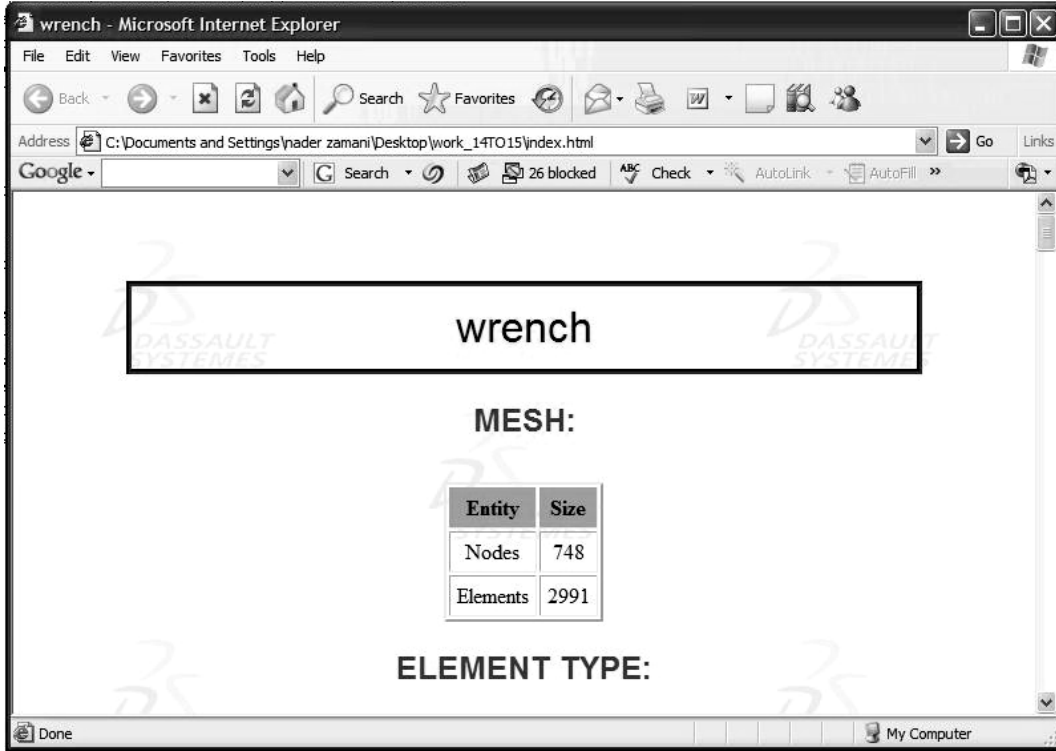

Finally, animation of the model can be achieved through the **Animate** icon  in the

Analysis Tools toolbar  and AVI files can easily be generated.

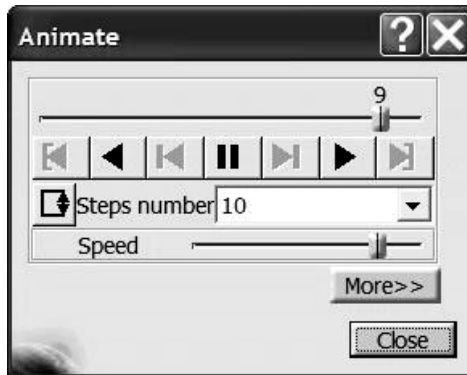

Exercises for Chapter 2

Problem 1: Analysis of a Foot Pedal

The foot pedal shown below is made of steel with Young's modulus $30E+6$ psi and Poisson ratio 0.3. The pedal is loaded with a normal force of 100 lb along the edge shown. The other end of the pedal is clamped. The geometrical dimensions are provided at the bottom of the page where all the dimensions are in inches.

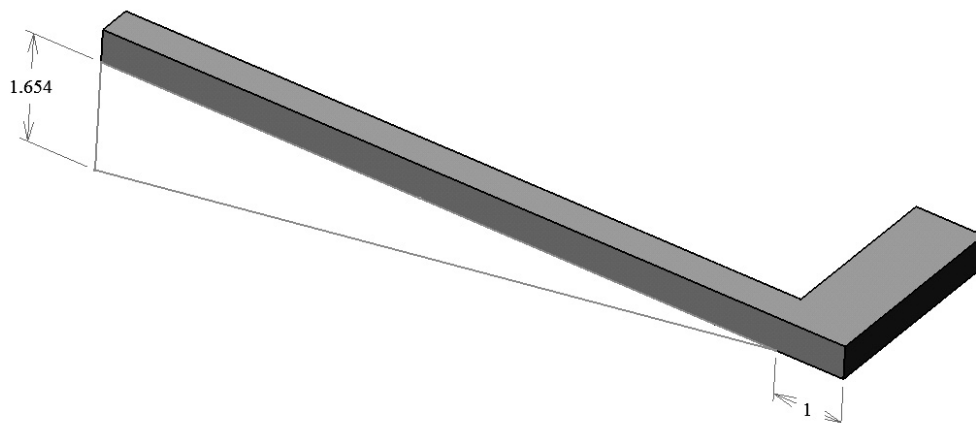
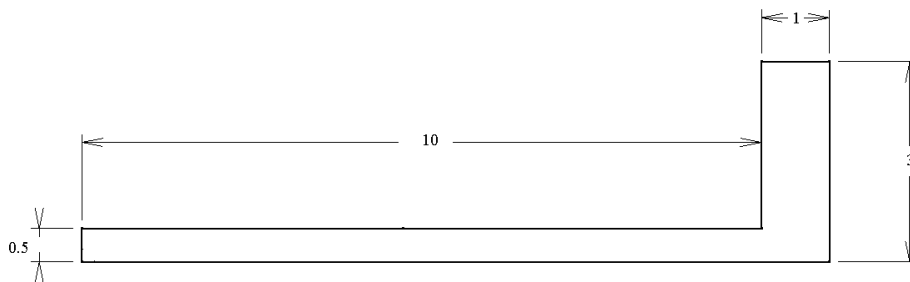
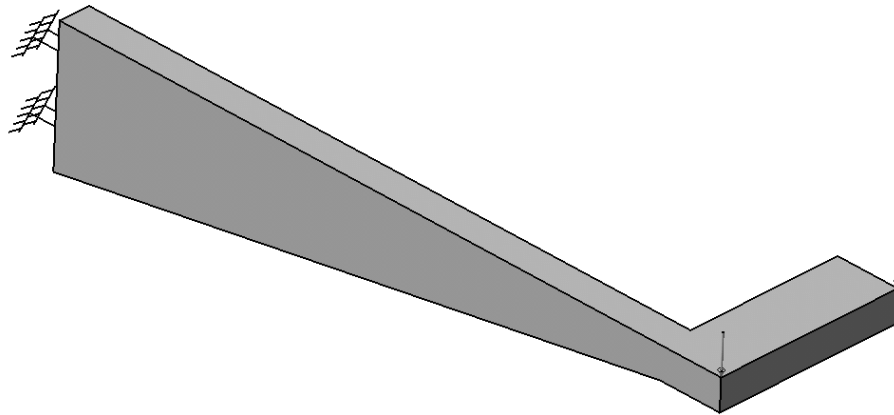

Try running the model with the two different element “size” and “sag” with both the linear and parabolic type of elements. Record the results in terms of the maximum displacement and the maximum von Mises stress in a table and comment on the results. The run time of the parabolic elements with element size of 0.1 could be substantial depending on the type of processor used.

Partial Answer:

Size = .3, sag = .05		
Element Type	Linear	Parabolic
Maximum Displacement	.0158 in.	.0227 in.
Maximum von Mises Stress	5.32E+3 psi	1.1E+4 psi

Size = .1, sag = .05		
Element Type	Linear	Parabolic
Maximum Displacement	.021 in.	.0229 in.
Maximum von Mises Stress	9.43E+4 psi	1.6E+4 psi

The above tables reveal an extremely important fact about finite element analysis. Making a single run and accepting the results at face value is a serious mistake. Note that for linear elements as the mesh is refined, there is a significant change in both displacement and von Mises stress. The user should not accept either value as being correct and must refine the mesh further. The refinement should reach a point at which the difference with the previous mesh is not deemed to be significant to user. This process is referred to as a mesh convergence study.

Keep in mind that the refinement need not be uniform throughout the part. One should perform the refinement in the critical areas only. It is clear that parabolic elements are superior in accuracy to linear element. Furthermore, note that although the displacement seems to have stabilized, the von Mises is still unreliable. It is well known that the displacements in FEA are more accurate than stresses. The reason is that the stresses are obtained by differentiating the displacement, a process which magnifies the error.

Problem 2: Analysis of a Cylindrical Bar under Torsion

The cylindrical bar shown below has a clamped end. The other end is subjected to a couple caused by opposite forces on magnitude 1000 lb separated by 1.5 in. This is equivalent to a torque of 1500 lb.in applied to the cylinder. The material is steel with Young's modulus $30E+6$ and Poisson ratio of 0.3.

The diameter of the cylinder is 1 in. and the dimensions of the loaded end are shown below. Although not showing, the length of the padded cylinder is 5 in. and the length of the padded rectangle is 0.5 in. All sharp corners at the loaded end have surface fillet of radius 0.1 in.

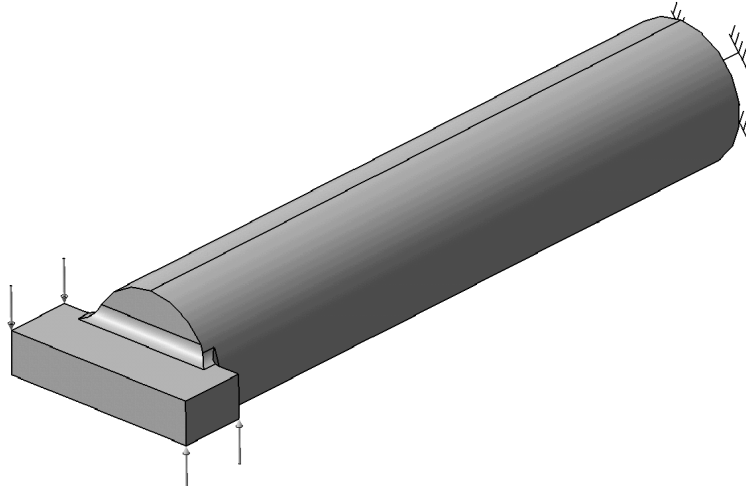

draw the rectangle on the circular face, then pad it away .5 in

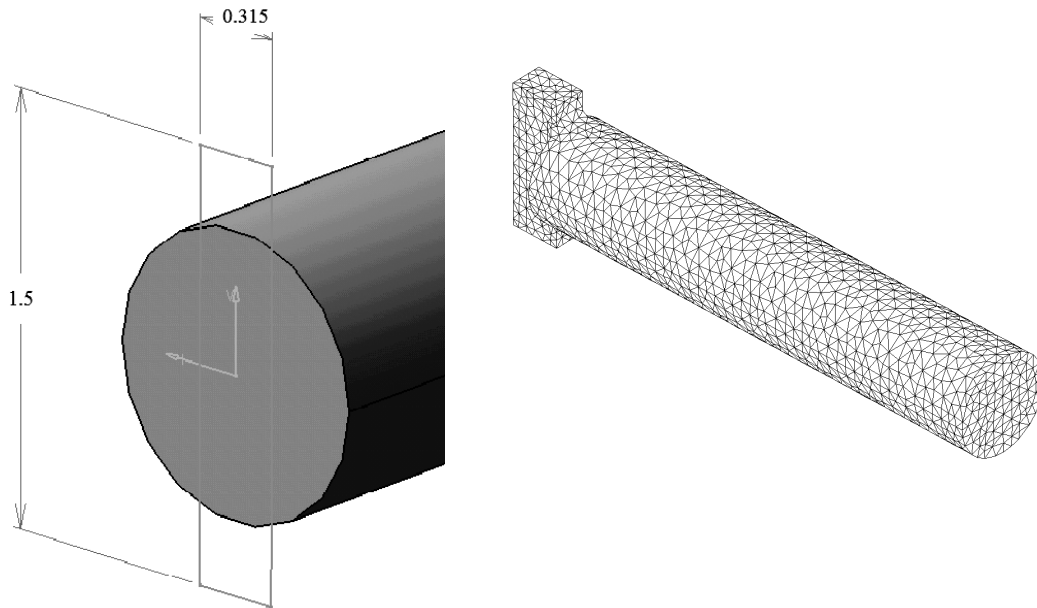

Model the part with linear solid elements with size = 0.1 and sag = 0.025 which results in the mesh shown in the previous page. Compare the hoop stress (The hoop stress is the largest principal stress “C11”) with the theoretical solution from strength of materials.

Partial Answer:

The strength of materials solution is based on $\tau = \frac{Tr}{J}$ where T is the applied torque, r is the radius of the cylinder and J is the polar moment of inertia. In terms of the diameter, $r = \frac{D}{2}$, and $J = \frac{\pi D^4}{32}$. The hoop stress “C11” which numerically equals τ is calculated from $\frac{16T}{\pi D^3}$. For the present problem, T = 1500 lb.in and D = 1 in. Based on these parameters, a value of 7643 psi for the hoop stress is predicted.

The FEA results can be assessed by plotting the contour of “C11” at the clamped section. The resulting plot shown below agrees quite well with 7643 psi obtained earlier. The circular fringe patterns are another qualitative check on the validity of the FEA results.

