

SolidWorks® 2013 and Engineering Graphics

An Integrated Approach

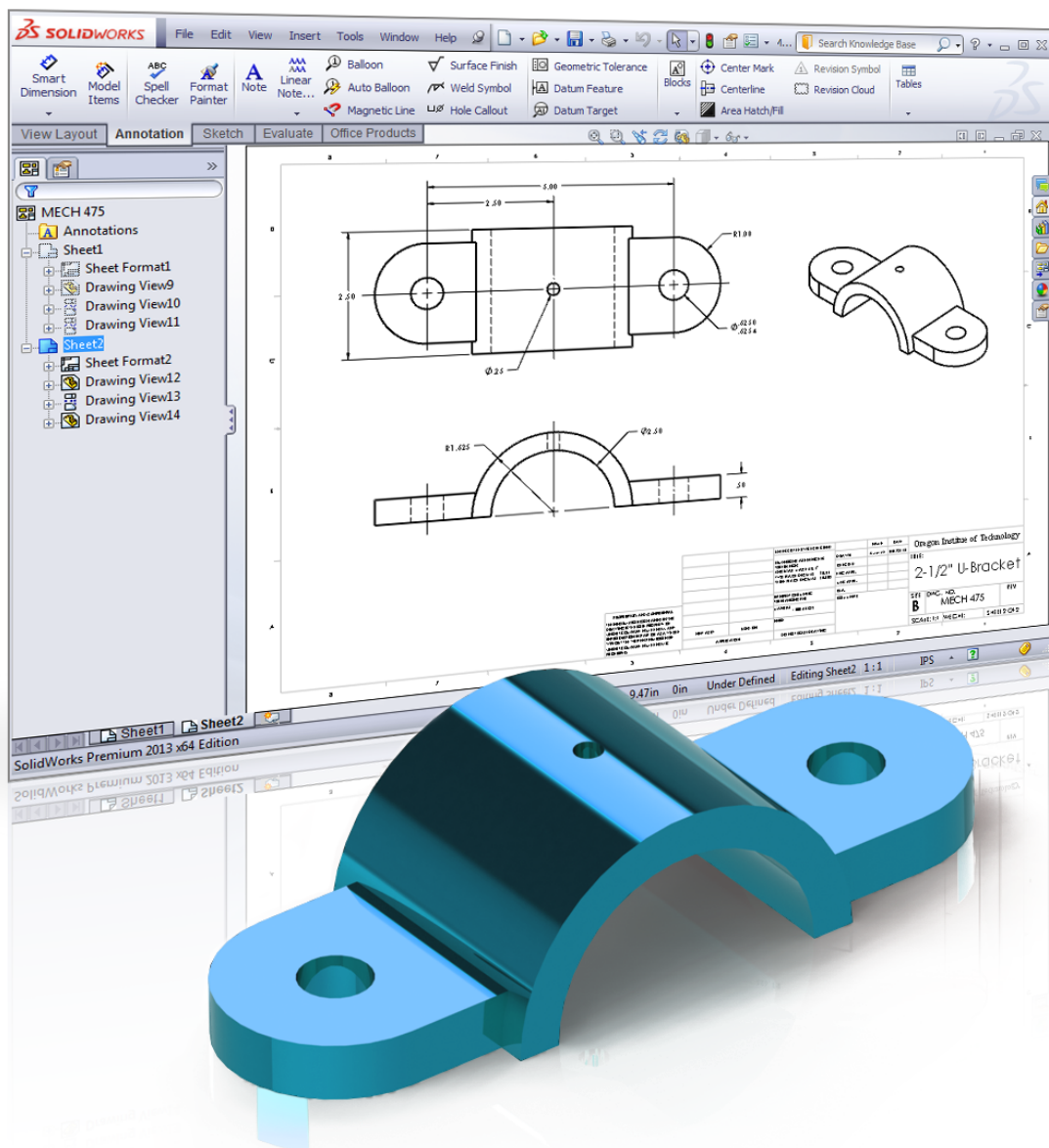

Randy H. Shih

Visit the following websites to learn more about this book:



[amazon.com](https://www.amazon.com)

[BARNES & NOBLE](https://www.barnesandnoble.com)

[Google books](https://books.google.com)

Chapter 3

Constructive Solid Geometry Concepts

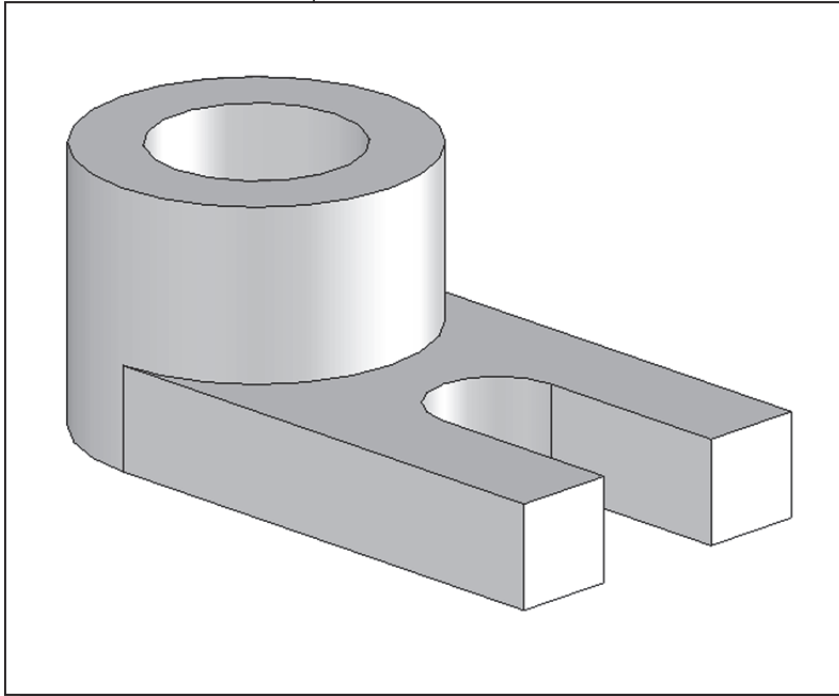

Learning Objectives

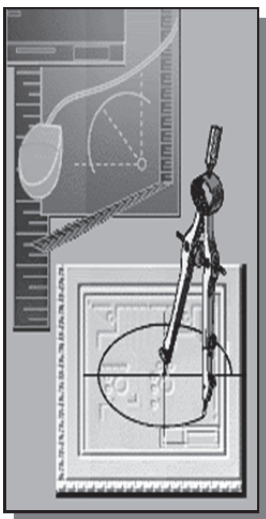

- ◆ **Understand Constructive Solid Geometry Concepts**
- ◆ **Create a Binary Tree**
- ◆ **Understand the Basic Boolean Operations**
- ◆ **Use the SolidWorks CommandManager User Interface**
- ◆ **Setup GRID and SNAP Intervals**
- ◆ **Understand the Importance of Order of Features**
- ◆ **Use the Different Extrusion Options**

Certified SolidWorks Associate Exam Objectives Coverage

Sketch Entities – Lines, Rectangles, Circles, Arcs, Ellipses, Centerlines

Objectives: Creating Sketch Entities.

Rectangle Command 3-11
Circle Command..... 3-14

Boss and Cut Features – Extrudes, Revolves, Sweeps, Lofts

Objectives: Creating Basic Swept Features.

Base Feature..... 3-10
Reverse Direction Option 3-16
Hole Wizard 3-20

Dimensions

Objectives: Applying and Editing Smart Dimensions.

Reposition Smart Dimension 3-12

Feature Conditions – Start and End

Objectives: Controlling Feature Start and End Conditions.

Extruded Cut, Up to Next..... 3-23

Introduction

In the 1980s, one of the main advancements in **solid modeling** was the development of the **Constructive Solid Geometry (CSG)** method. CSG describes the solid model as combinations of basic three-dimensional shapes (**primitive solids**). The basic primitive solid set typically includes: Rectangular-prism (Block), Cylinder, Cone, Sphere, and Torus (Tube). Two solid objects can be combined into one object in various ways using operations known as **Boolean operations**. There are three basic Boolean operations: **JOIN (Union)**, **CUT (Difference)**, and **INTERSECT**. The *JOIN* operation combines the two volumes included in the different solids into a single solid. The *CUT* operation subtracts the volume of one solid object from the other solid object. The *INTERSECT* operation keeps only the volume common to both solid objects. The CSG method is also known as the **Machinist's Approach**, as the method is parallel to machine shop practices.

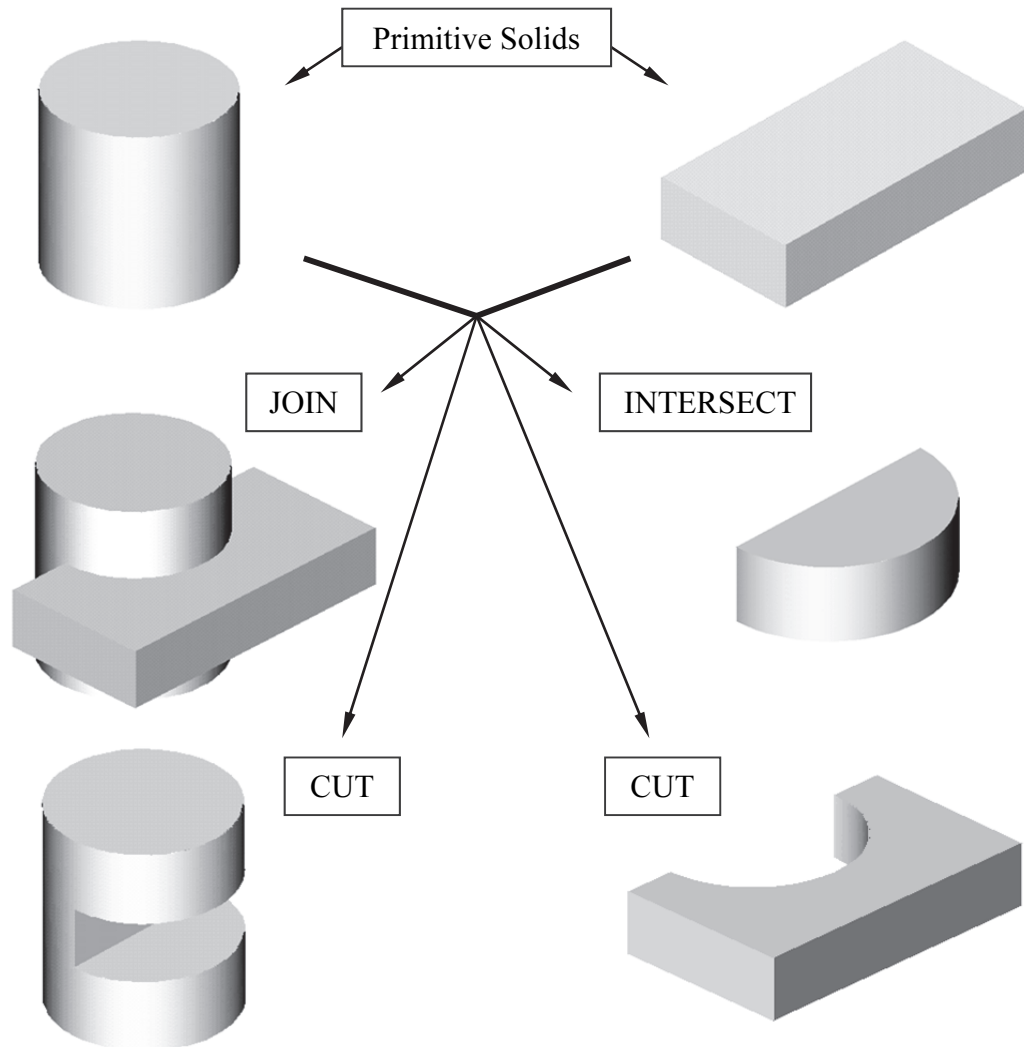

Binary Tree

The CSG is also referred to as the method used to store a solid model in the database. The resulting solid can be easily represented by what is called a **binary tree**. In a binary tree, the terminal branches (leaves) are the various primitives that are linked together to make the final solid object (the root). The binary tree is an effective way to keep track of the *history* of the resulting solid. By keeping track of the history, the solid model can be re-built by re-linking through the binary tree. This provides a convenient way to modify the model. We can make modifications at the appropriate links in the binary tree and re-link the rest of the history tree without building a new model.

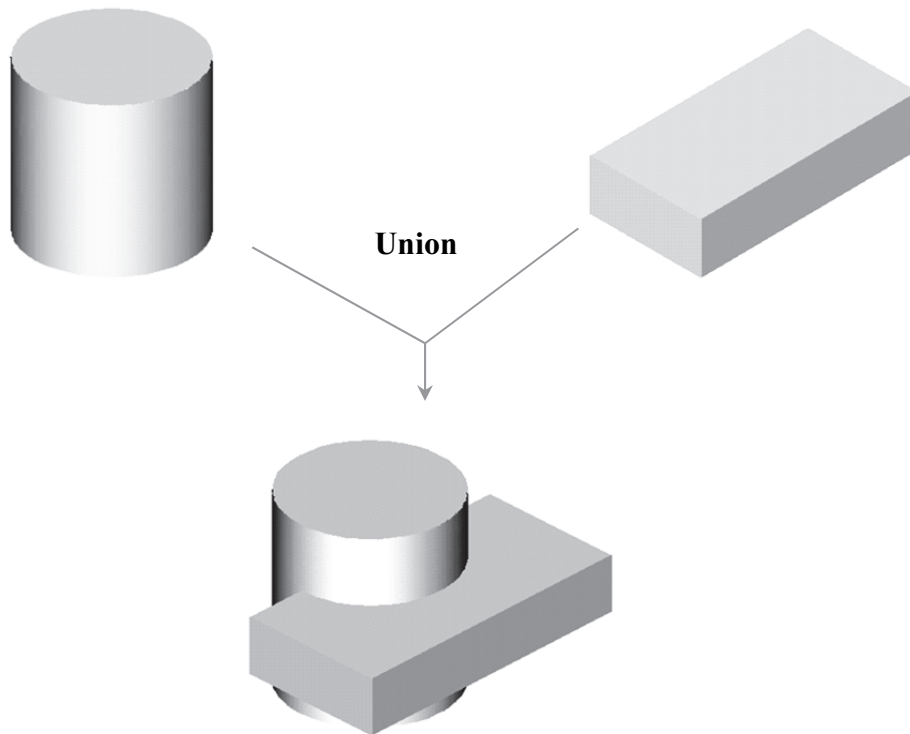
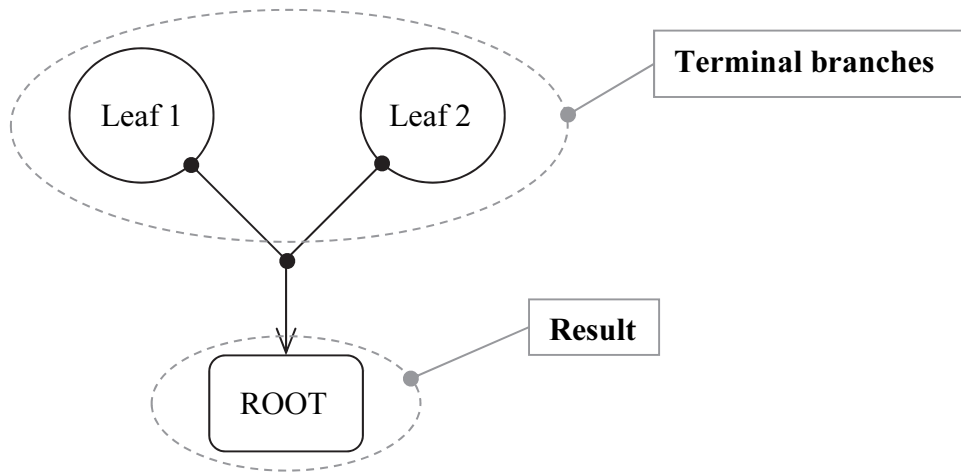

The *Locator* Design

The CSG concept is one of the important building blocks for feature-based modeling. In *SolidWorks*, the CSG concept can be used as a planning tool to determine the number of features that are needed to construct the model. It is also a good practice to create features that are parallel to the manufacturing process required for the design. With parametric modeling, we are no longer limited to using only the predefined basic solid shapes. In fact, any solid features we create in *SolidWorks* are used as primitive solids; parametric modeling allows us to maintain full control of the design variables that are used to describe the features. In this lesson, a more in-depth look at the parametric modeling procedure is presented. The equivalent CSG operation for each feature is also illustrated.

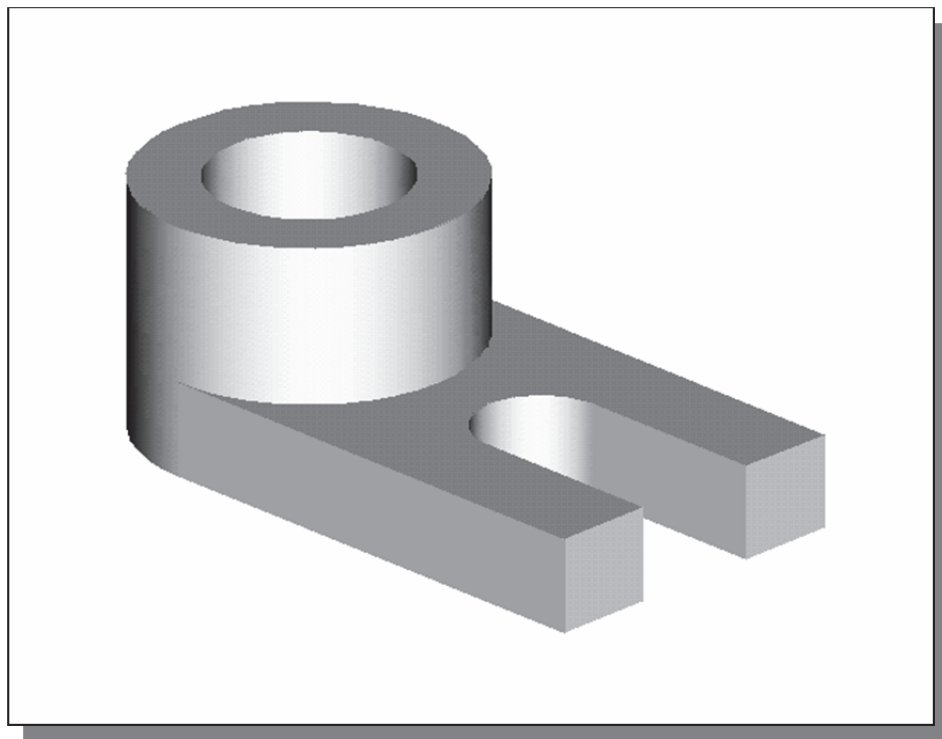

- Before going through the tutorial, on your own, make a sketch of a CSG binary tree of the **Locator** design using only two basic types of primitive solids: cylinder and rectangular prism. In your sketch, how many *Boolean operations* will be required to create the model? What is your choice of the first primitive solid to use, and why? Take a few minutes to consider these questions and do the preliminary planning by sketching on a piece of paper. Compare the sketch you make to the CSG binary tree steps shown on page 3-5. Note that there are many different possibilities in combining the basic primitive solids to form the solid model. Even for the simplest design, it is possible to take several different approaches to creating the same solid model.

Modeling Strategy – CSG Binary Tree

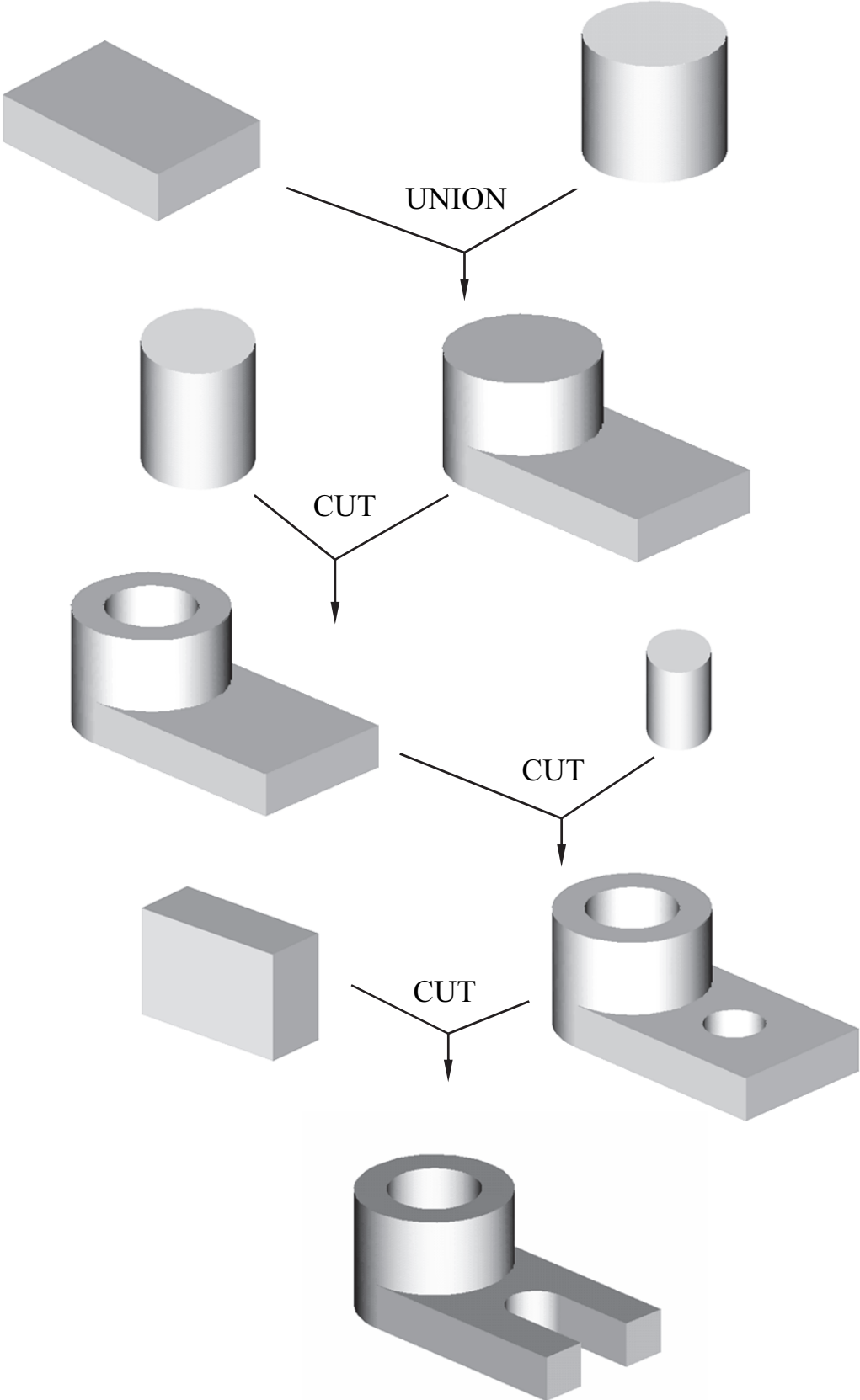

Starting SolidWorks and Activating the Command Manager

1. Select the **SolidWorks** option on the *Start* menu or select the **SolidWorks** icon on the desktop to start *SolidWorks*. The *SolidWorks* main window will appear.



2. Select the **New** icon with a single click of the left-mouse-button on the *Menu Bar* toolbar.

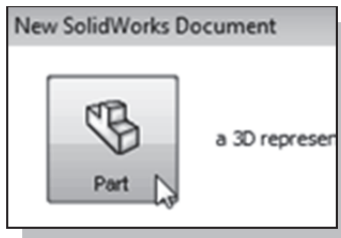

3. Select the **Part** icon with a single click of the left-mouse-button in the *New SolidWorks Document* dialog box.

4. Select **OK** in the *New SolidWorks Document* dialog box to open a new part document.

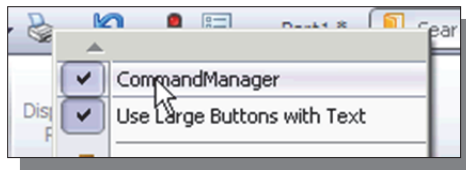

5. To turn **ON** the *Command Manager*, right click on any toolbar and toggle the *Command Manager ON* by selecting it at the top of the pop-up menu.

- ❖ Notice the *Features* and *Sketch* toolbars no longer appear at the edge of the window. These toolbars appear on the *Ribbon* display of the *Command Manager*.

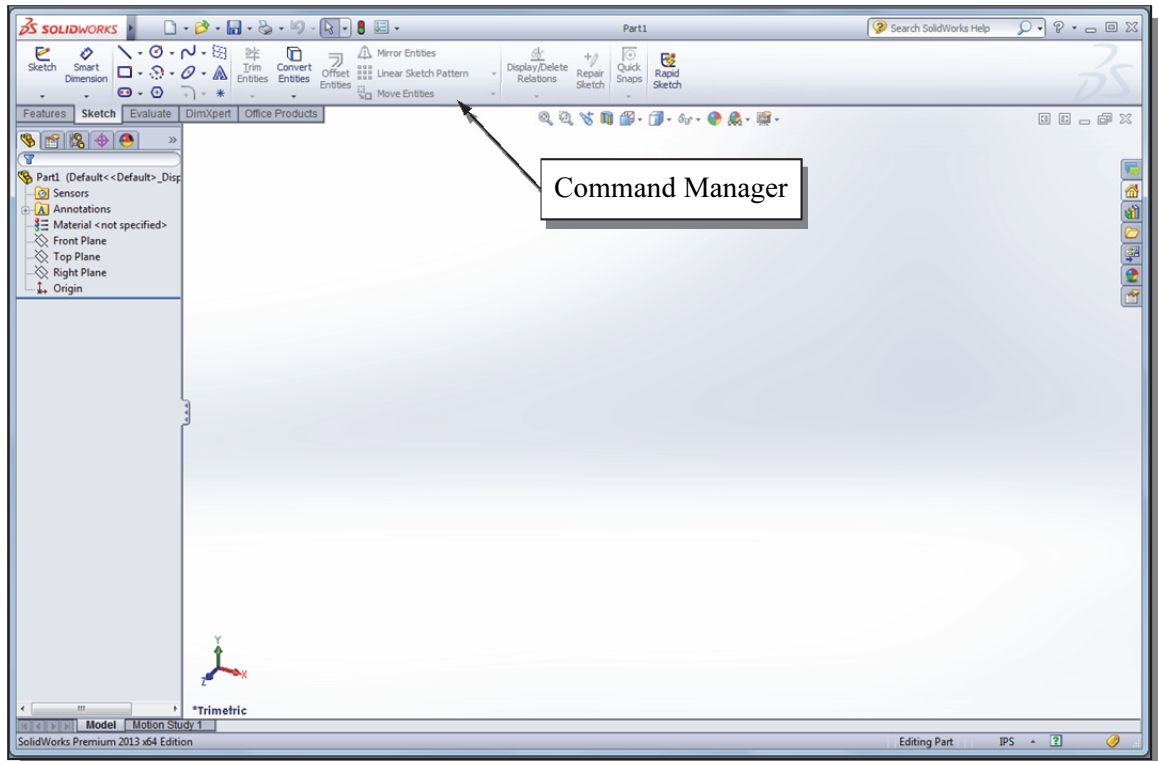

- Every object we construct in a CAD system is measured in units. We should determine the value of the units within the CAD system before creating the first geometric entities. For example, in one model, a unit might equal one millimeter of the real-world object; in another model, a unit might equal an inch. In most CAD systems, setting the model units does not always set units for dimensions. We generally set model units and dimension units to the same type and precision.
6. Select the **Options** icon from the *Menu Bar* toolbar to open the *Options* dialog box.

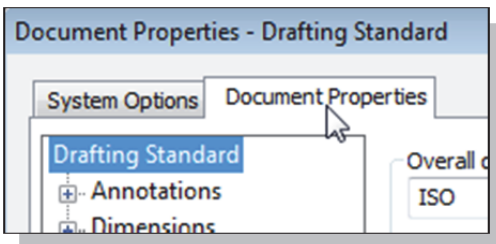
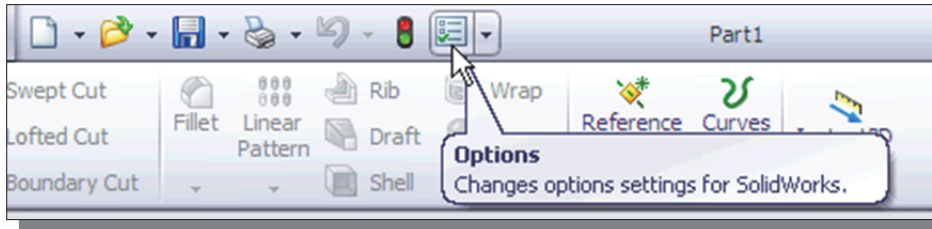

7. Select the **Document Properties** tab and the **Drafting Standard** option at the left of the *Document Properties* panel.

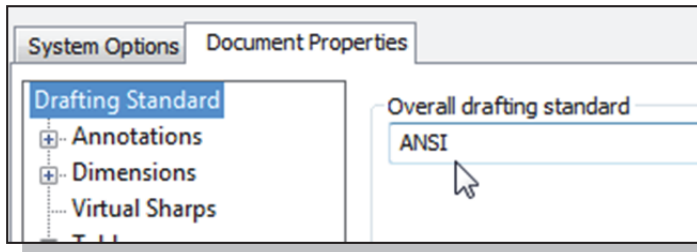

8. Select **ANSI** in the pull-down selection window under the *Overall drafting standard* panel as shown.

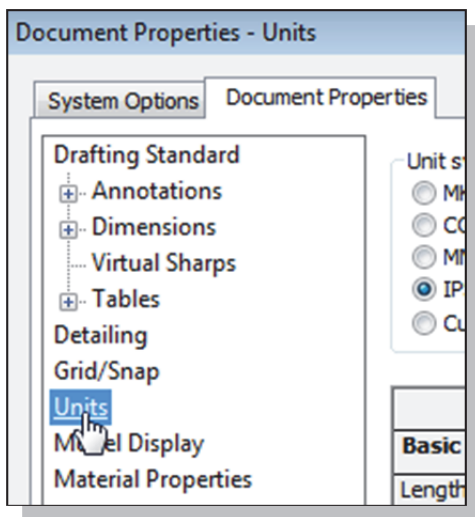

9. Click **Units** as shown in the figure.

10. Select **MMGS (millimeter, gram, second)** under the *Unit system* options.

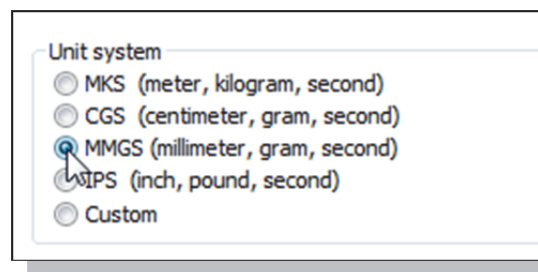

11. Select **None** in the *Decimals* spin box for the *Length units* as shown to set the display to no decimal places. (Note the *Overall Drafting Standard* is automatically adjusted with our setting as shown.)

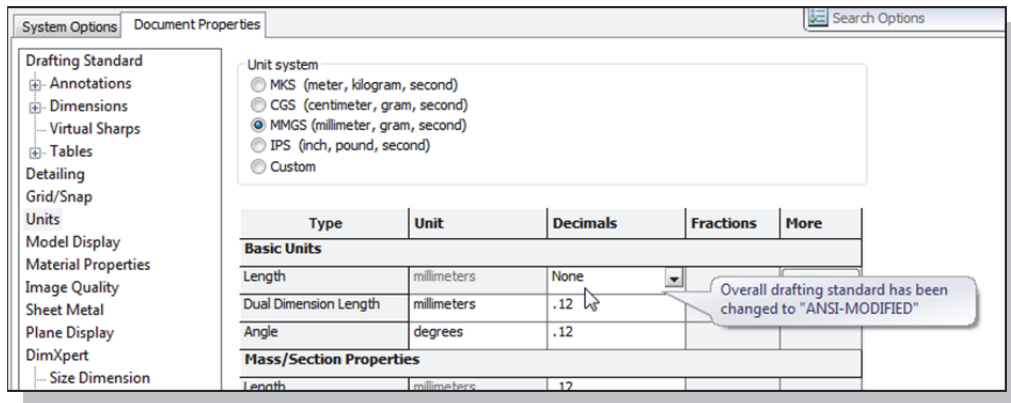

GRID and SNAP Intervals Setup

1. Click **Grid/Snap** as shown below.

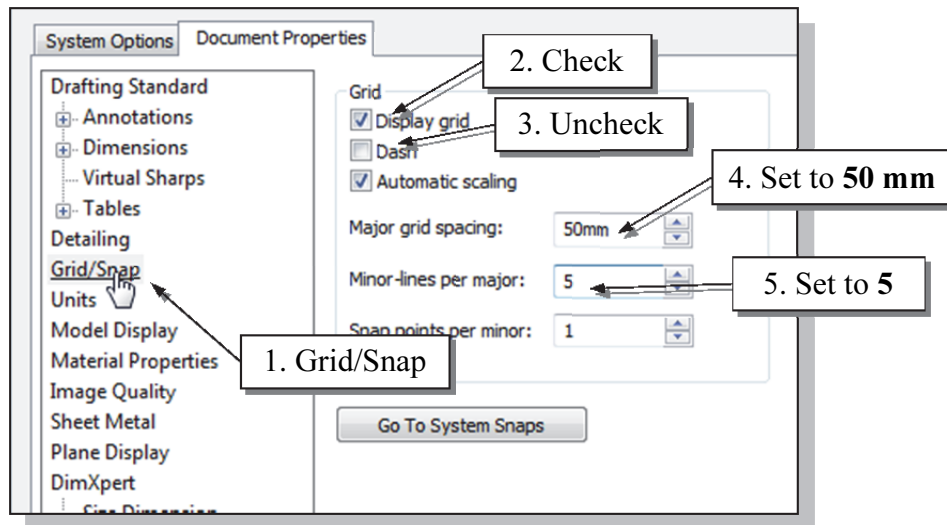

2. Check the **Display grid** checkbox under the *Grid* options.
3. Uncheck the **Dash** checkbox under the *Grid* options.
4. Set the **Major grid spacing** to **50 mm** under the *Grid* options.
5. Set the **Minor-lines per major** to **5** under the *Grid* options.

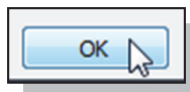

6. Click **OK** in the *Options* dialog box to accept the selected settings.

- Note that the above settings set the grid displaying in *SolidWorks*. Although the **Snap to grid** option is available in *SolidWorks*, its usage in parametric modeling is not recommended.

Base Feature

In *parametric modeling*, the first solid feature is called the **base feature**, which usually is the primary shape of the model. Depending upon the design intent, additional features are added to the base feature.

Some of the considerations involved in selecting the base feature are:

- **Design intent** – Determine the functionality of the design; identify the feature that is central to the design.
- **Order of features** – Choose the feature that is the logical base in terms of the order of features in the design.
- **Ease of making modifications** – Select a base feature that is more stable and is less likely to be changed.

➤ A rectangular block will be created first as the base feature of the **Locator** design.

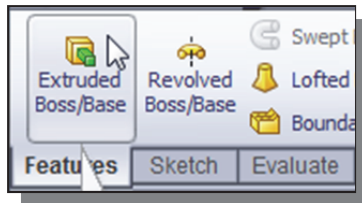

1. Select the **Extruded Boss/Base** button on the *Features* toolbar to create a new extruded feature.

2. Move the cursor over the edge of the **Top Plane** in the graphics area. When the **Top Plane** is highlighted, click once with the **left-mouse-button** to select the **Top Plane** (XZ Plane) as the sketch plane for the new sketch.

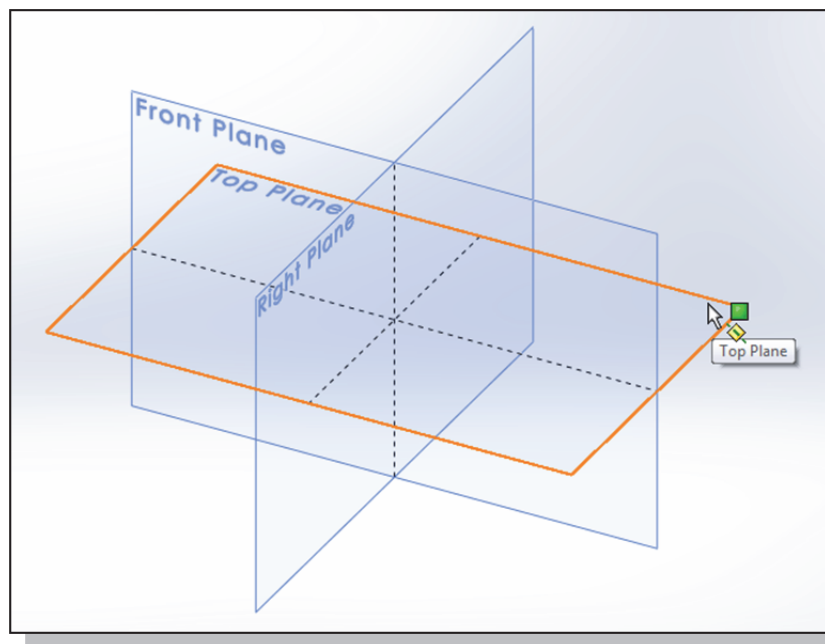

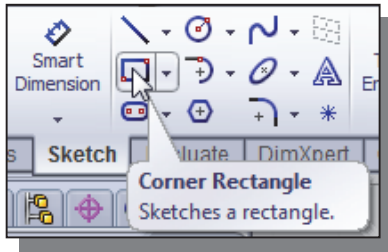

3. Select the **Corner Rectangle** command by clicking once with the **left-mouse-button** on the icon in the *Sketch* toolbar.

4. Create a rectangle of arbitrary size by selecting two locations on the screen as shown below.

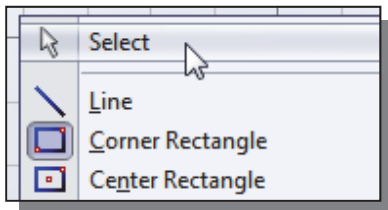
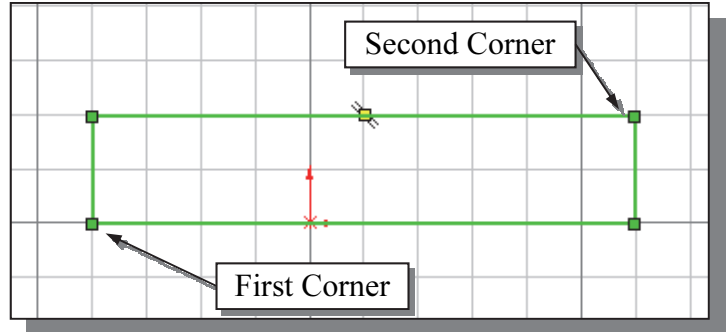

5. Inside the graphics window, click once with the right-mouse-button to bring up the option menu.
6. Choose **Select** to end the Rectangle command.

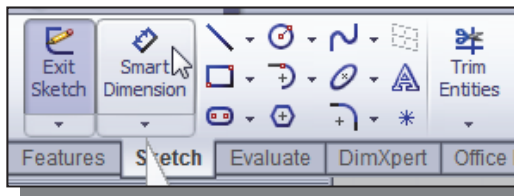

7. Select the **Smart Dimension** command by clicking once with the **left-mouse-button** on the icon in the *Sketch* toolbar.

8. The message “*Select one or two edges/vertices and then a text location*” is displayed in the *Status Bar* area at the bottom of the *SolidWorks* window. Select the bottom horizontal line by left-clicking once on the line.

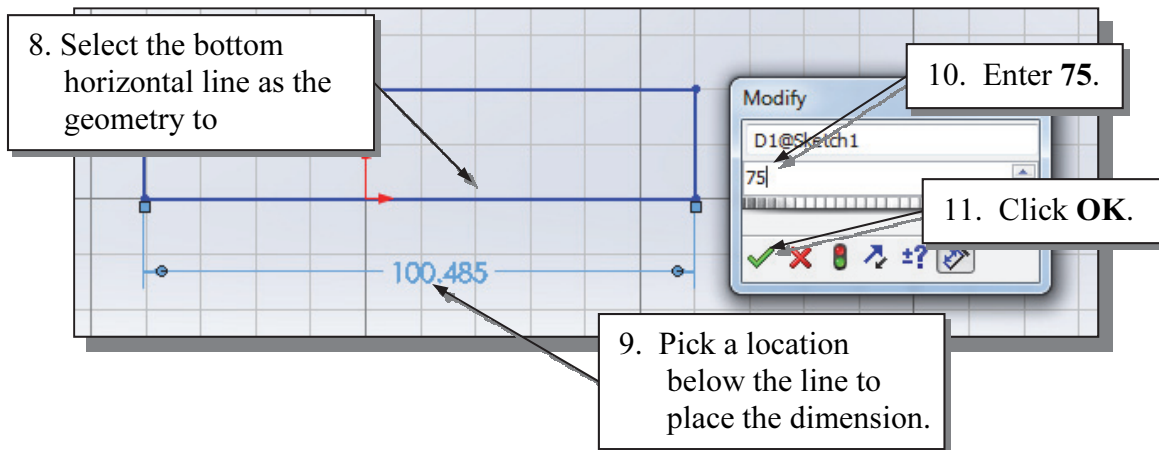

9. Move the graphics cursor below the selected line and left-click to place the dimension. (Note that the value displayed on your screen might be different than what is shown in the figure above.)
10. Enter **75** in the *Modify* dialog box.
11. Click **OK** in the *Modify* dialog box.

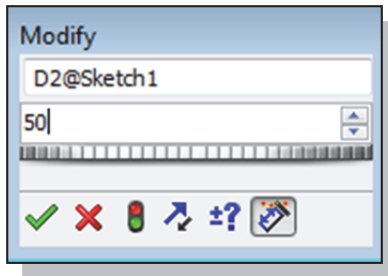

12. On your own, create the vertical size dimension of the sketched rectangle as shown. Enter **50** to set the length of the line.

13. Click on the **OK** icon to accept the entered value.

14. Hit the [**Esc**] key once to end the Dimension command

Repositioning Dimensions

1. Move the cursor near the vertical dimension; note that the dimension is highlighted. Move the cursor slowly until a small marker appears next to the cursor, as shown in the figure.
2. Drag with the left-mouse-button to reposition the selected dimension.
3. Repeat the above steps to reposition the horizontal dimension.

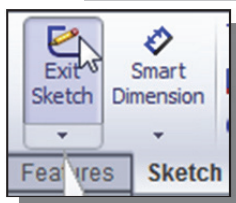
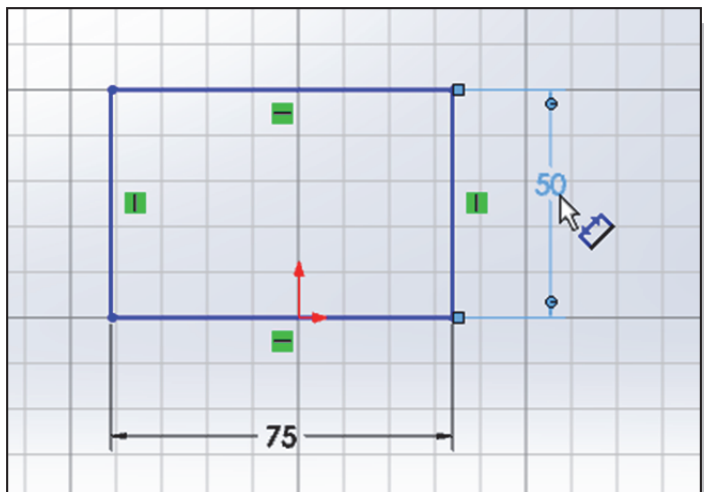

4. Click once with the **left-mouse-button** on the **Exit Sketch** icon on the *Sketch* toolbar to end the Sketch option.

Completing the Base Solid Feature

- In the *Extrude PropertyManager* panel, enter **15** as the extrusion distance. Notice that the sketch region is automatically selected as the extrusion profile.

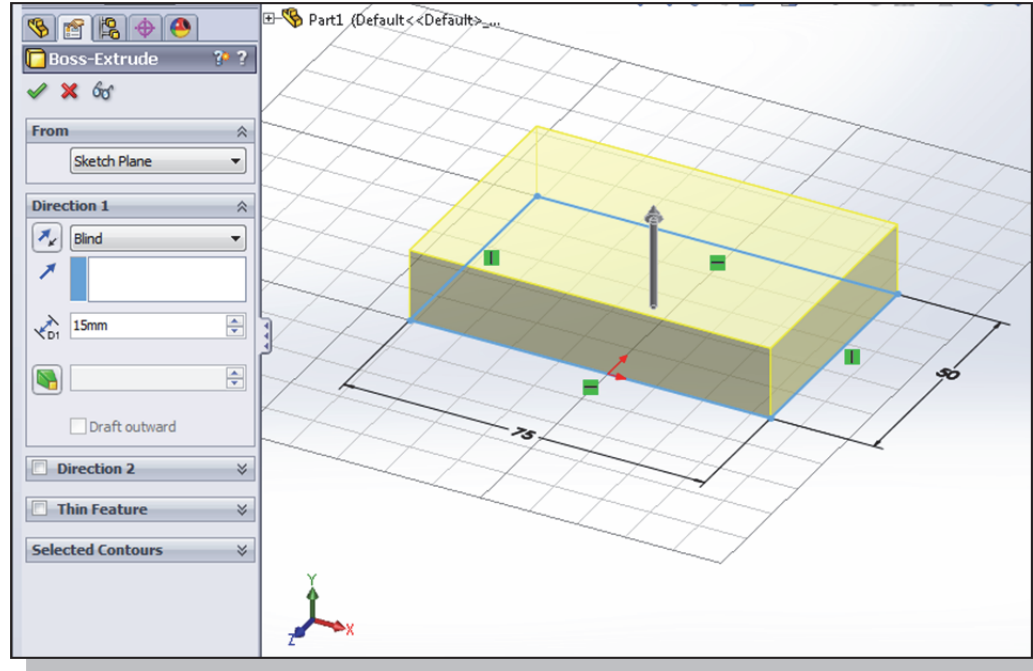

- Click on the **OK** button to proceed with creating the 3D part.
- Use the *Viewing* options to view the created part. On the *Heads-up View* toolbar, select **View Orientation** (to open the *View Orientation* pull-down menu) and select the **Isometric** icon to reset the display to the Isometric view before going to the next section.

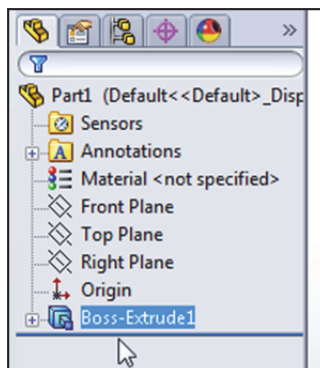
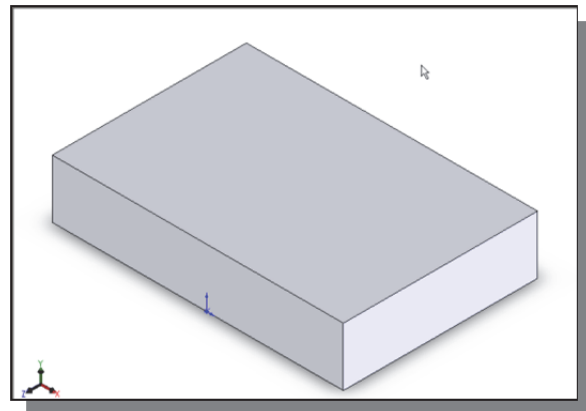

- Note the Extruded feature you created is listed in the *Feature Manager Design Tree* as shown. Note the Design Tree can be used to identify all features used to create the design.

Creating the Next Solid Feature

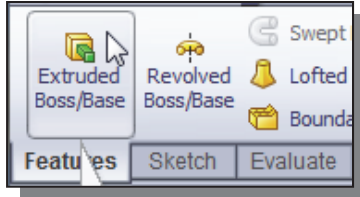

1. Select the **Extruded Boss/Base** button on the *Features* toolbar to create a new extruded feature.

2. Rotate the view by using the **up arrow** key to display the bottom face of the solid model as shown below.

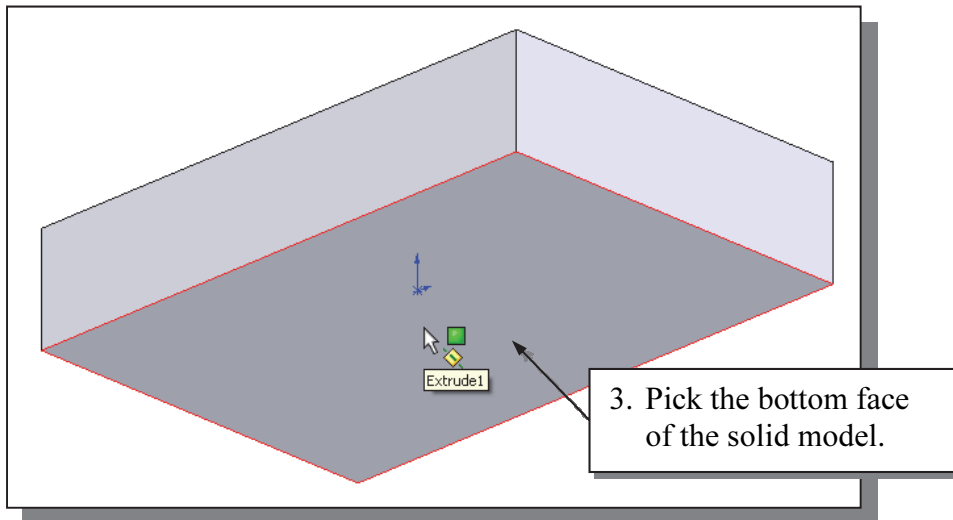

3. Pick the bottom face of the 3D model as the sketching plane.

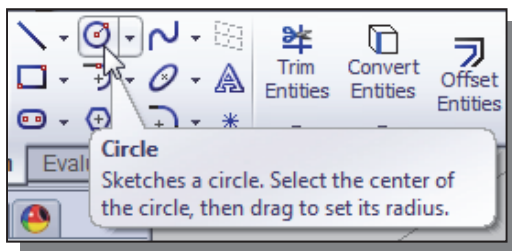

- Note that the sketching plane is aligned to the selected face.

4. Select the **Circle** command by clicking once with the left-mouse-button on the icon in the *Sketch* toolbar.

- We will align the center of the circle to the midpoint of the base feature.

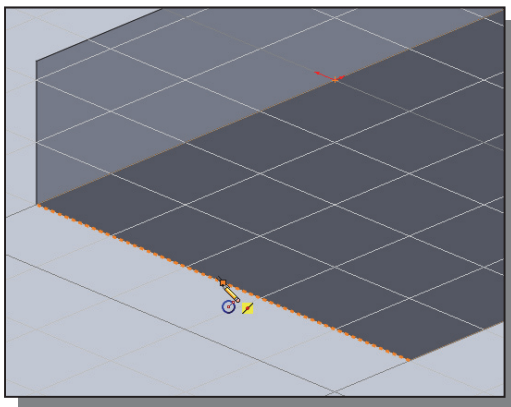

5. Move the cursor along the shorter edge of the base feature; when the **midpoint** is highlighted and the **Midpoint** sketch relation icon appears, click once with the left-mouse-button to select the midpoint.

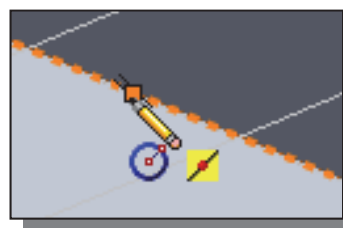

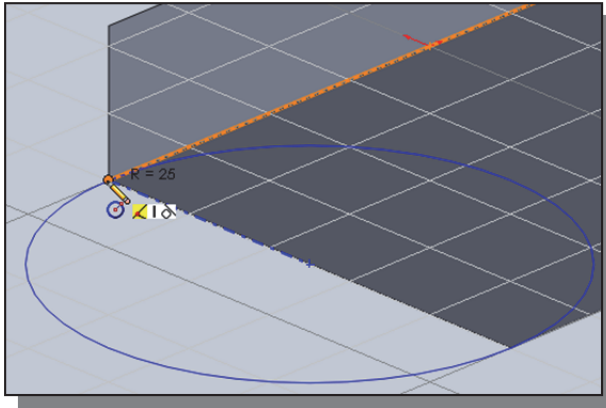

6. Move the cursor over the corner of the base feature; when the corner is highlighted, click once with the left-mouse-button to create a circle, as shown.
7. Press the **[Esc]** key once to end the Circle command.

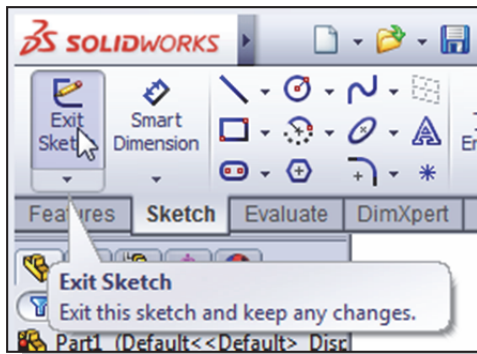

8. Click once with the **left-mouse-button** on the **Exit Sketch** icon on the *Sketch* toolbar to exit the Sketch option.

➤ Notice that the sketch region is automatically selected as the extrusion profile.

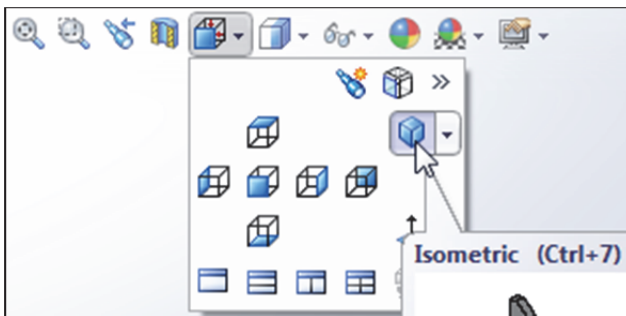

9. Select the **Isometric** icon in the *View Orientation* pull-down menu.

❖ Note that many other view-related commands are also available under the **View** pull-down menu.

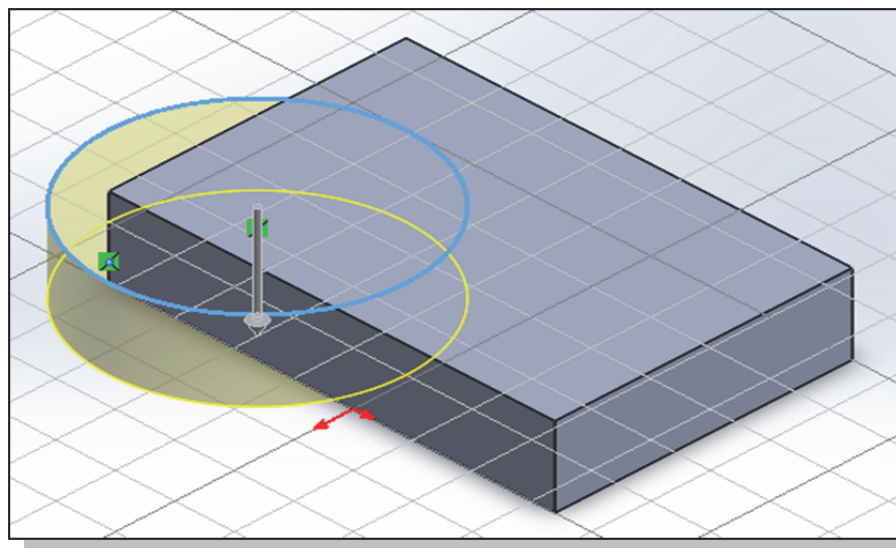

10. In the *Extrude Property Manager* panel, click the **Reverse Direction** icon to set the extrusion direction as shown below.

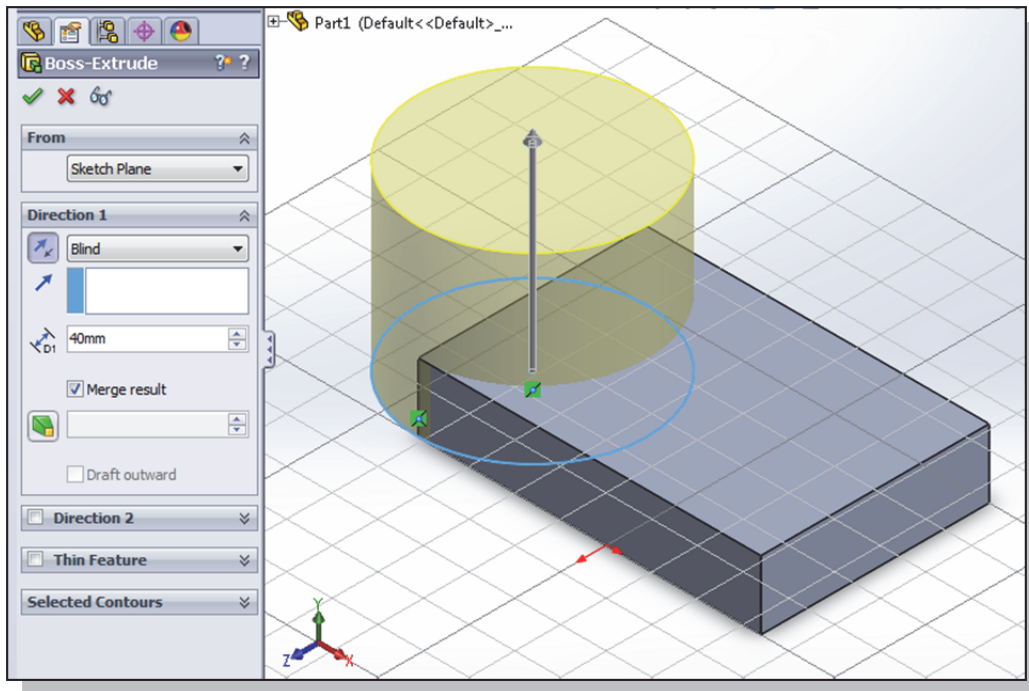

11. In the *Extrude Property Manager* panel, enter **40** as the extrusion distance.
12. Confirm the **Merge result** checkbox is checked as shown.
13. Click on the **OK** button to proceed with creating the extruded feature.

- The two features are joined together into one solid part; the *CSG-Union* operation was performed. This is the effect of the *Merge result* option.

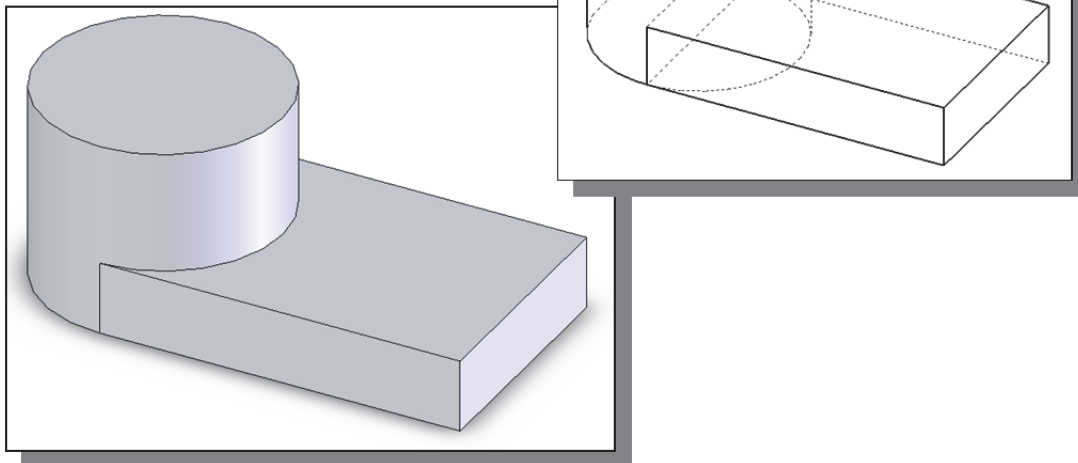

Creating an Extruded Cut Feature

- We will create a circular cut as the next solid feature of the design. We will align the sketch plane to the top of the last cylinder feature.

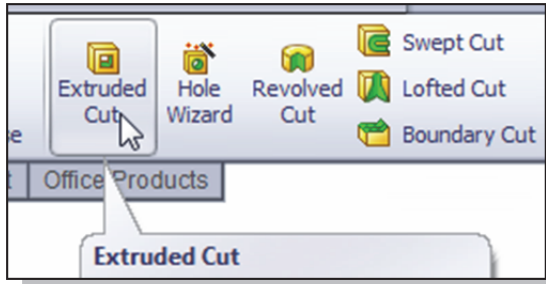

1. In the *Features* toolbar select the **Extruded Cut** command by clicking once with the left-mouse-button on the icon.

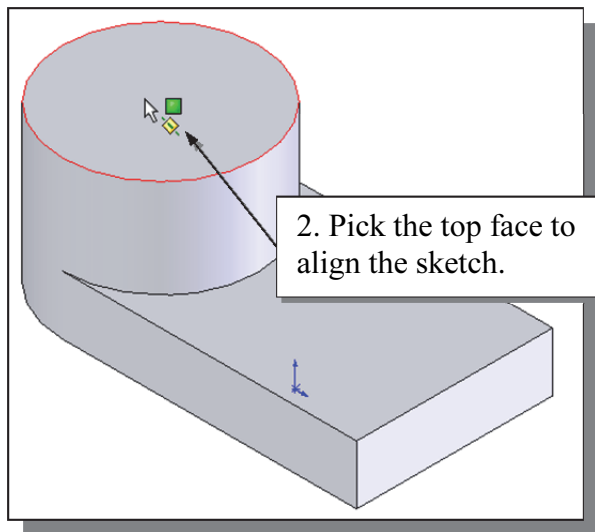

2. Pick the top face of the cylinder as shown.

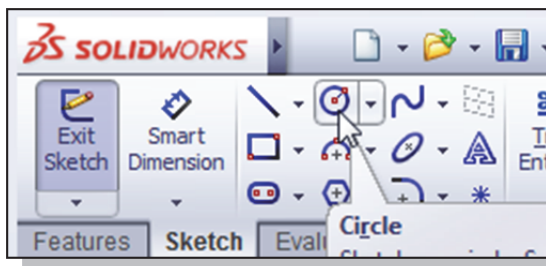

3. Select the **Circle** command by clicking once with the left-mouse-button on the icon in the *Sketch* toolbar.

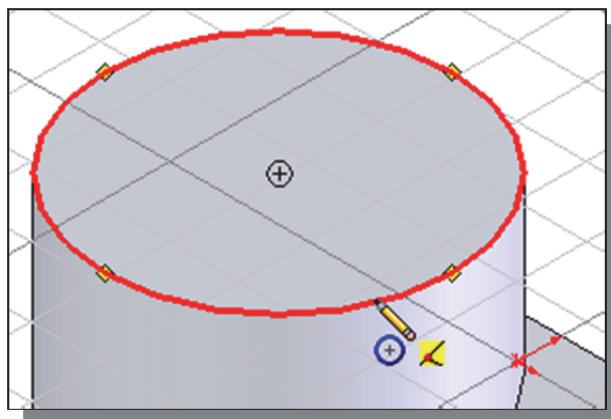

4. Move the cursor over the circular edge of the top face as shown. (Do not click.) Notice the center and quadrant marks appear on the circle.

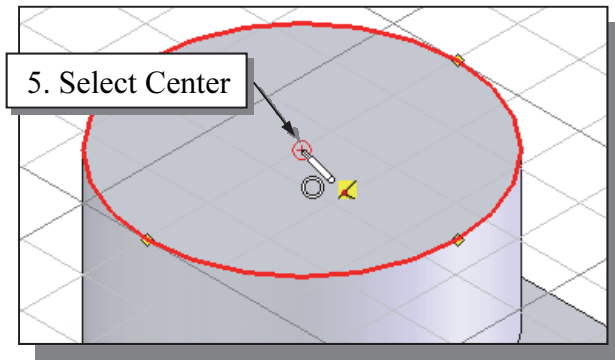

5. Select the **Center** point of the top face of the 3D model by left-clicking once on the icon as shown.

6. Sketch a circle of arbitrary size inside the top face of the cylinder by left-clicking as shown.

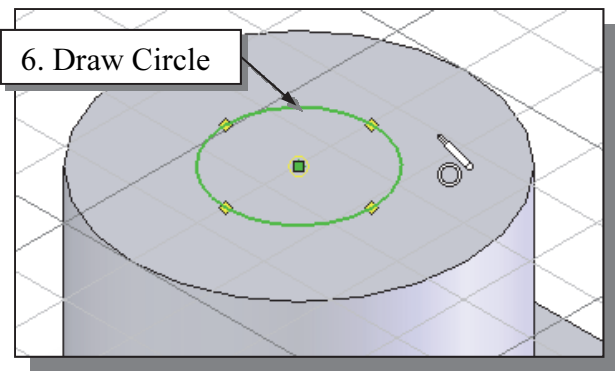

7. Use the right-mouse-button to display the option menu and choose **Select** in the popup menu to end the Circle command.

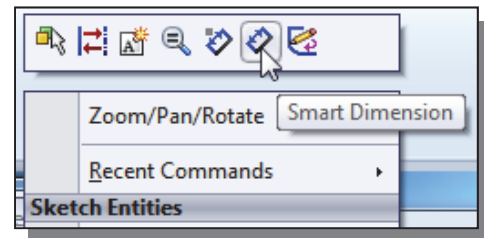
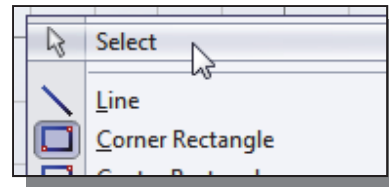

8. Inside the graphics window, click once with the right-mouse-button to display the option menu. Select the **Smart Dimension** option in the popup menu.

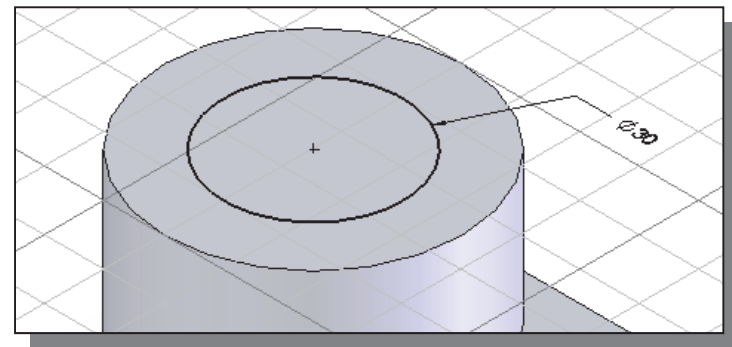

9. Create a dimension to describe the size of the circle and set it to **30mm**.



10. Inside the graphics window, click once with the right-mouse-button to display the option menu. Choose **Select** in the popup menu to end the Smart Dimension command.

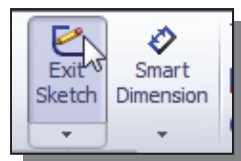

11. Click once with the **left-mouse-button** on the **Exit Sketch** icon on the *Sketch* toolbar to exit the Sketch option.

- The *Cut-Extrude PropertyManager* is displayed in the left panel. Notice that the sketch region (the circle) is automatically selected as the extrusion profile.
12. In the *Cut-Extrude PropertyManager* panel, click the arrow to reveal the pull-down options for the *End Condition* (the default end condition is 'Blind') and select **Through All** as shown.

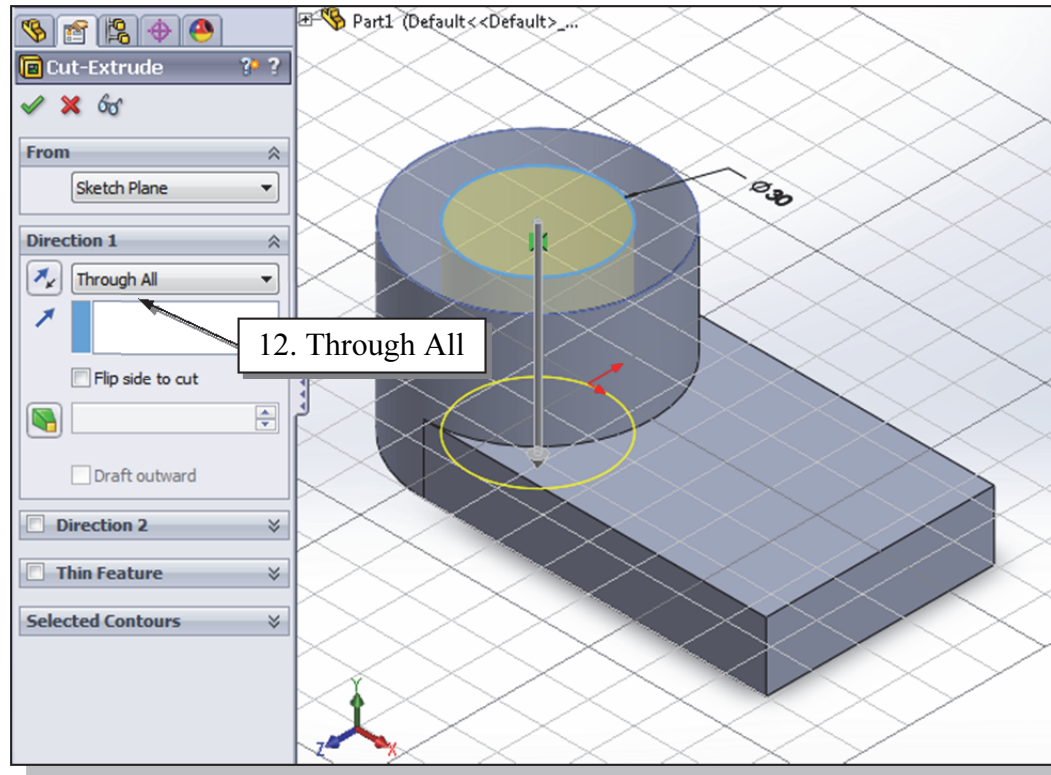

13. Click the **OK** button (green check mark) in the *Cut-Extrude PropertyManager* panel.

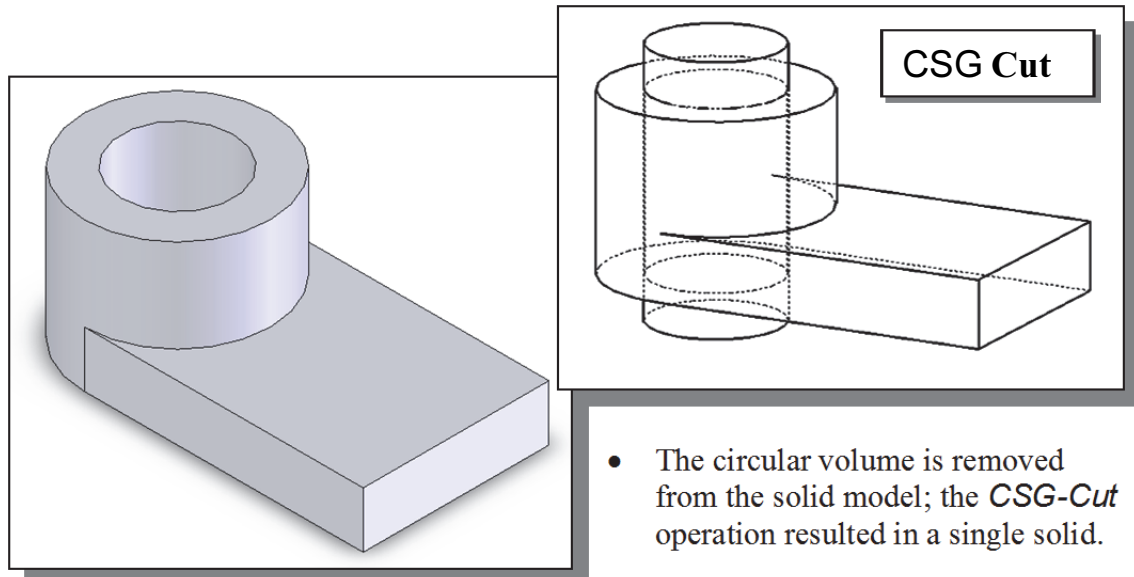

Creating a Hole with the *Hole Wizard*

- The last cut feature we created is a *sketched feature*, where we created a rough sketch and performed an extrusion operation. We can also create a hole using the *SolidWorks Hole Wizard*. With the *Hole Wizard*, the hole feature does not need a sketch and can be created automatically. Holes, fillets, chamfers, and shells are all examples of features that do not require a sketch.

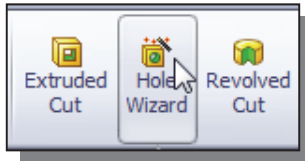

- In the *Features* toolbar, select the **Hole Wizard** command by clicking once with the left-mouse-button on the icon as shown.

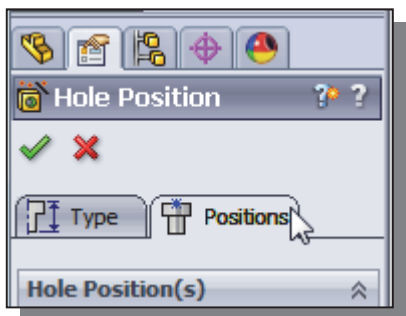

- In the *Hole Specification Property Manager*, select the **Positions** panel by clicking once with the left-mouse-button on the **Positions** tab as shown. The **Positions** tab allows you to locate the hole on a planar or non-planar face.

- Move the cursor over the horizontal surface of the base feature. Notice that the surface is highlighted. Click the **left mouse button** to select a location inside the horizontal surface as the position for the hole.

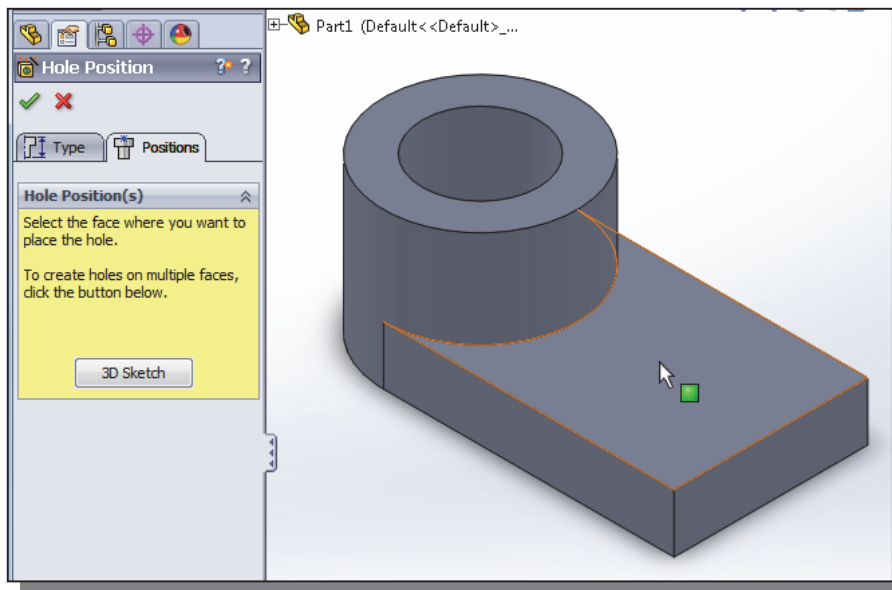

- Notice the *Sketch* toolbar is active and the **Point** button is now selected. The **Point** command has been automatically executed to allow the insert of a point to serve as the center for the hole. We will insert the point and use dimensions to locate it.

4. Move the cursor to a location on the horizontal surface of the base feature as shown and click the **left mouse button** to insert the point.

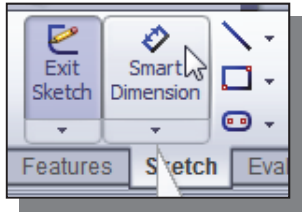
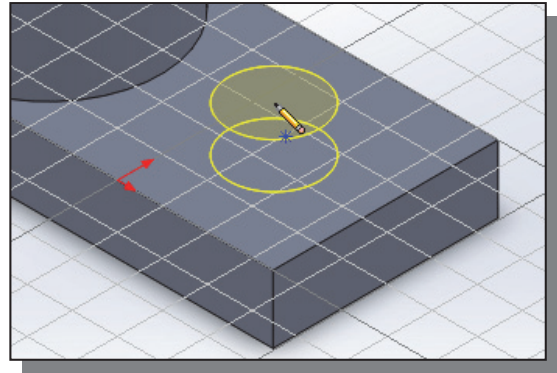

5. Select the **Smart Dimension** command by clicking once with the **left-mouse-button** on the icon in the *Sketch* toolbar.

6. Pick the center point by clicking once with the left-mouse-button as shown.
7. Pick the right-edge of the top face of the base feature by clicking once with the left-mouse-button as shown.
8. Select a location for the dimension by clicking once with the left-mouse-button as shown.

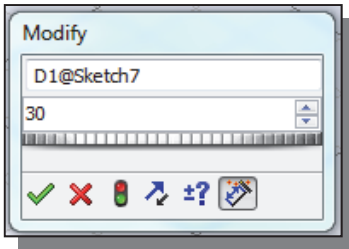
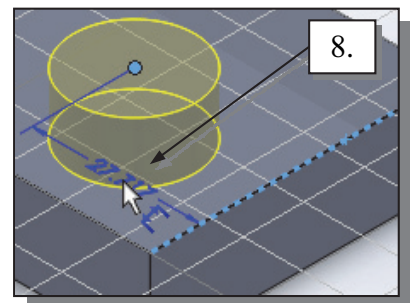
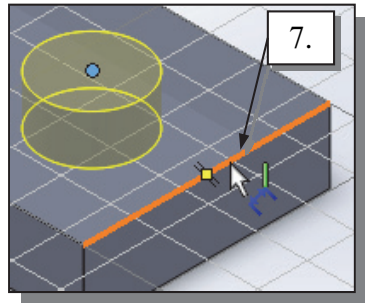
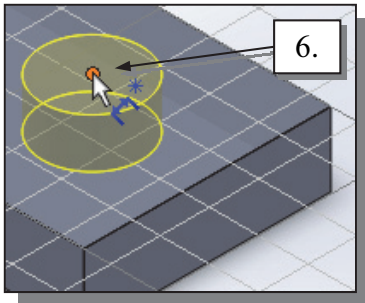

9. Enter **30** in the *Modify* dialog box, and select **OK**.

10. On your own, enter the additional dimension as shown (the dimension is **25 mm**).

11. Press the **[Esc]** key once to end the Smart Dimension command.

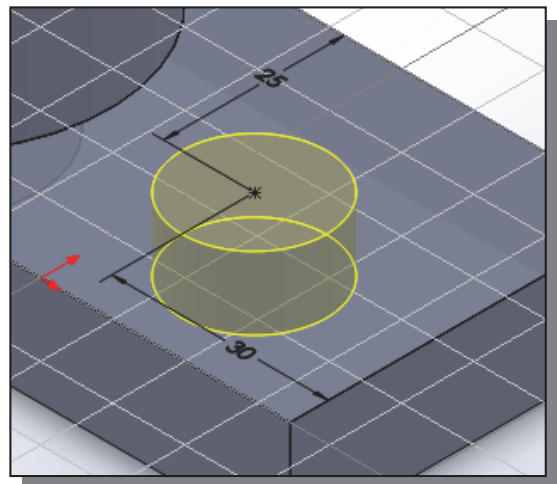

12. In *Hole Property Manager*, select the **Type** panel by clicking once with the left-mouse-button on the **Type** tab as shown.

12. Select the **Type** tab.

13. Select the **Hole** icon under the *Hole Specification* option. (This is the default setting and is probably already selected.)

13. Select **Hole** button.

14. Select **Ansi Metric** and **Drill Size** in the *Standard* option window.

14. Select **Ansi Metric** and **Drill Size**.

15. Set the *Size* option to a diameter of **20** mm.

15. Set to **20 mm**.

16. Set the *End Condition* option to **Through All**.

16. Select **Through All**.

17. Click the **OK** button (green check mark) in the *Hole Property Manager* to proceed with the *Hole* feature.

- The circular volume is removed from the solid model; the *CSG-Cut* operation resulted in a single solid.

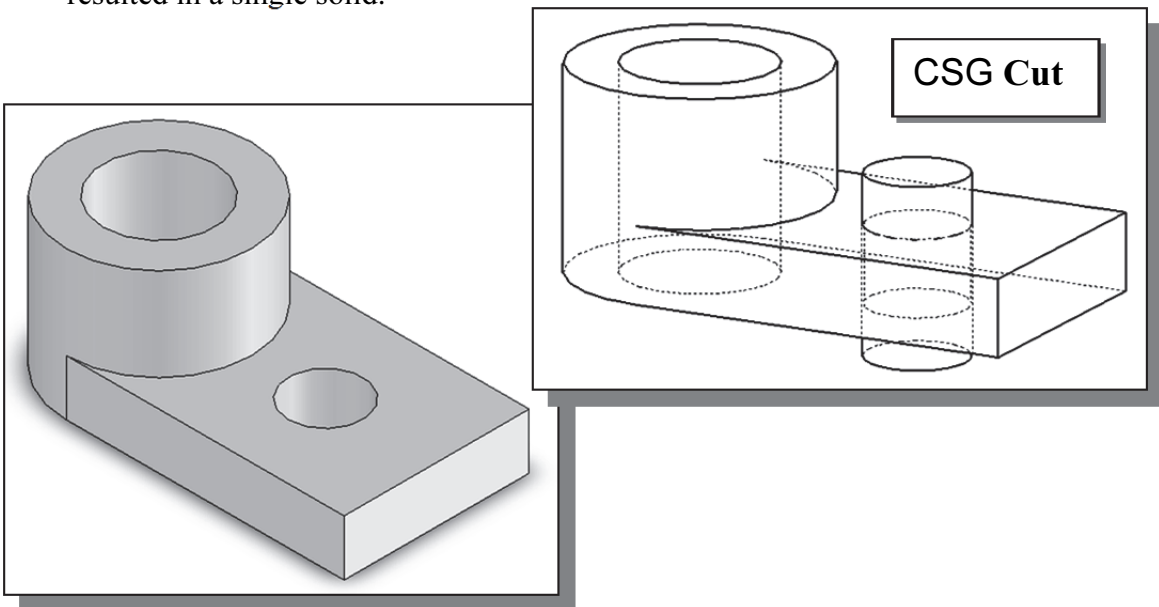

Creating a Rectangular Extruded Cut Feature

- Next create a rectangular cut as the last solid feature of the **Locator**.

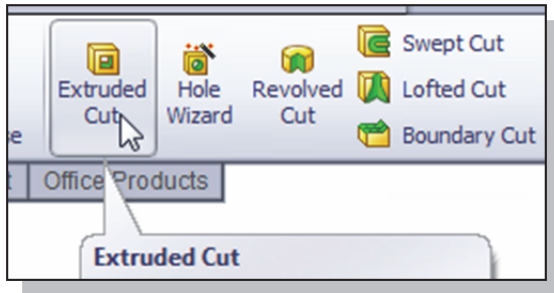

- In the *Features* toolbar select the **Extruded Cut** command by clicking once with the left-mouse-button on the icon.

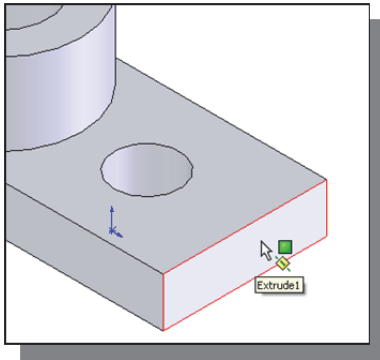

- Pick the right face of the base feature as shown.

- Select the **Corner Rectangle** command by clicking once with the left-mouse-button on the icon in the *Sketch* toolbar.

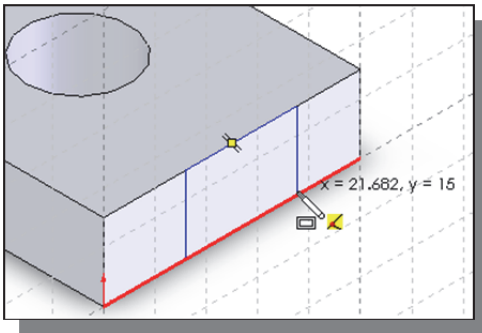
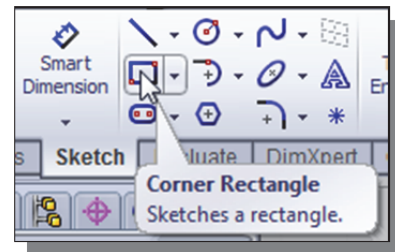

- Create a rectangle that is aligned to the top and bottom edges of the base feature as shown.

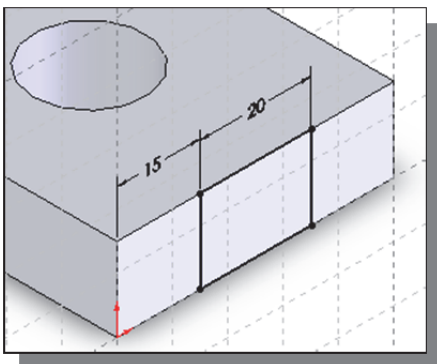

- On your own, create and modify the two dimensions as shown. The dimensions are **15** mm and **20** mm.

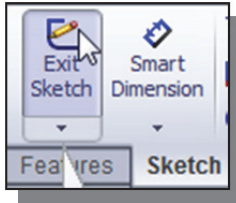

6. Click once with the **left-mouse-button** on the **Exit Sketch** icon on the *Sketch* toolbar to exit **Sketch** option.

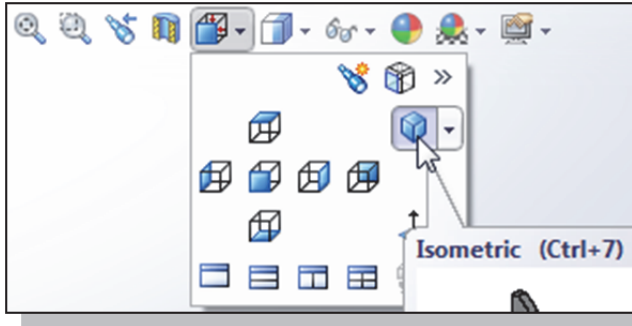

7. Select the **Isometric** icon in the *View Orientation* pull-down menu.

❖ Note that many other view-related commands are also available under the **View** *pull-down menu*.

8. In the *Extrude Property Manager* panel, click the arrow to reveal the pull-down options for the *End Condition* (the default end condition is **Blind**) and select **Up To Next** as shown.

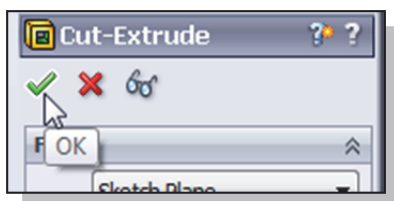
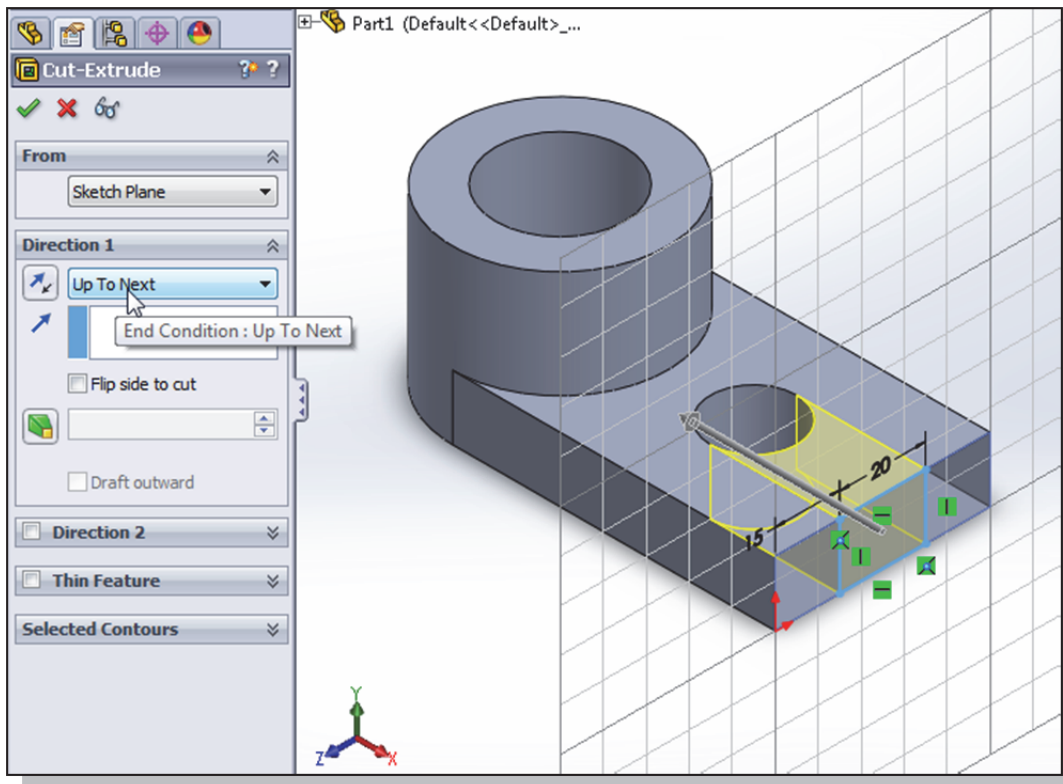

9. Click the **OK** button (green check mark) in the *Cut-Extrude Property Manager* panel.

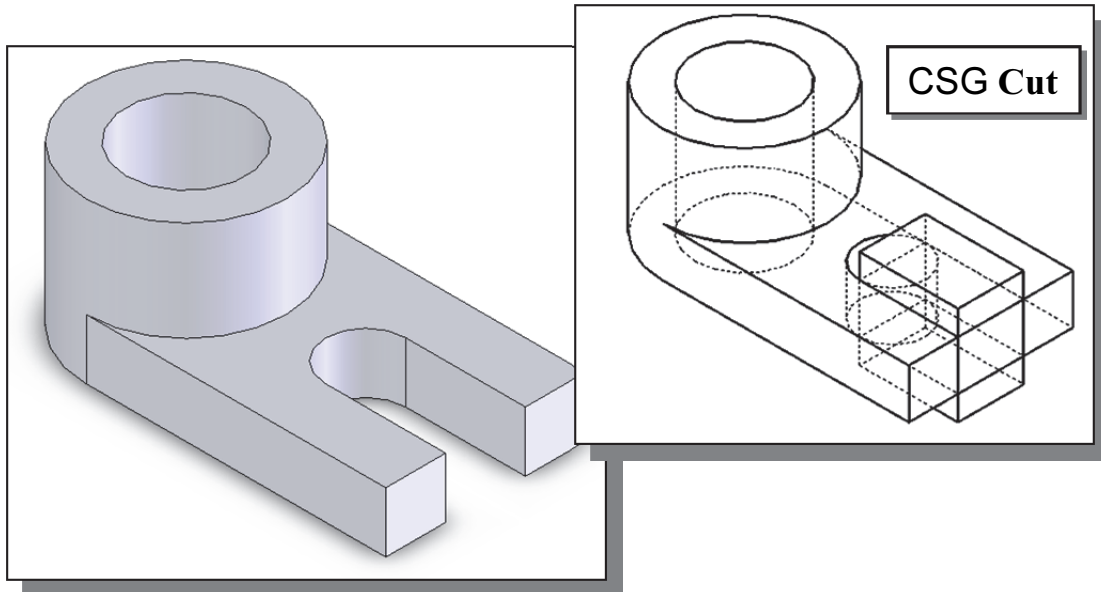

Using the View Selector

The **View Selector** provides an in-context method to select standard and non-standard views.

1. Click on the **View Orientation** icon on the *Heads-Up View Toolbar* to reveal the view orientation options.

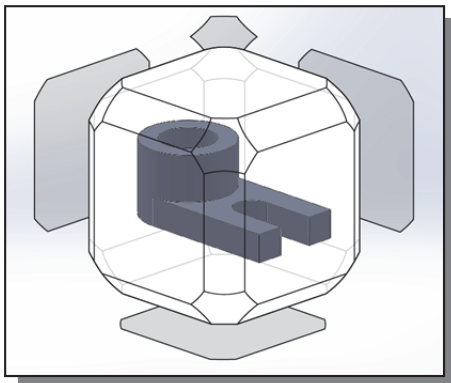
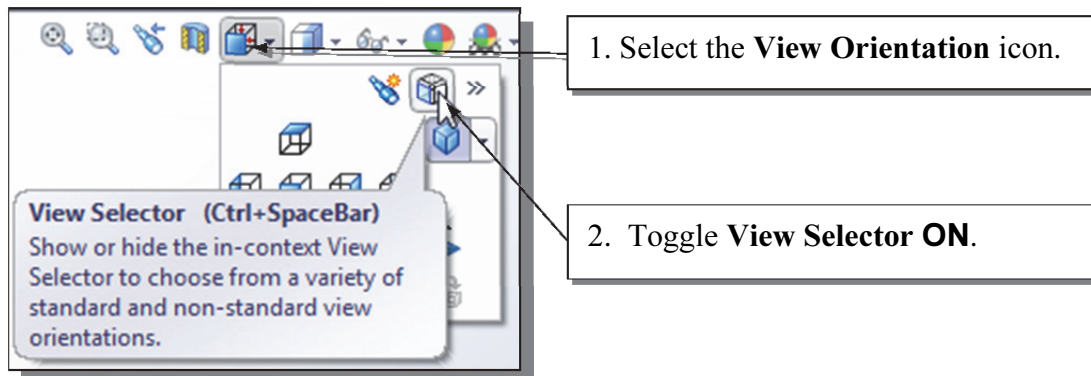

2. **Toggle** the View Selector **ON** by left-clicking on the **View Selector** icon in the *Orientation dialog box*.

➤ The View Selector appears in the graphics area. The View Selector provides an in-context method to select right, left, front, back, top, and isometric views of your model, as well as additional standard and isometric views.

3. Select the **bottom isometric view** on the *View Selector* as shown below. Note the corresponding view appears.

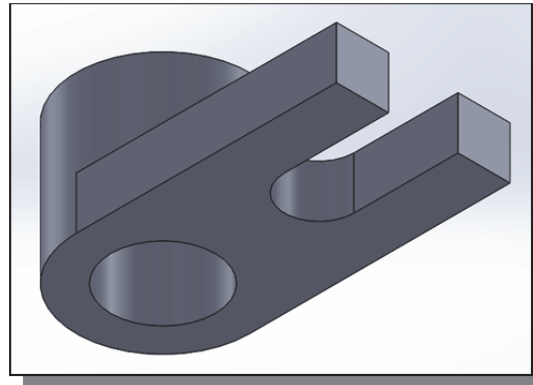
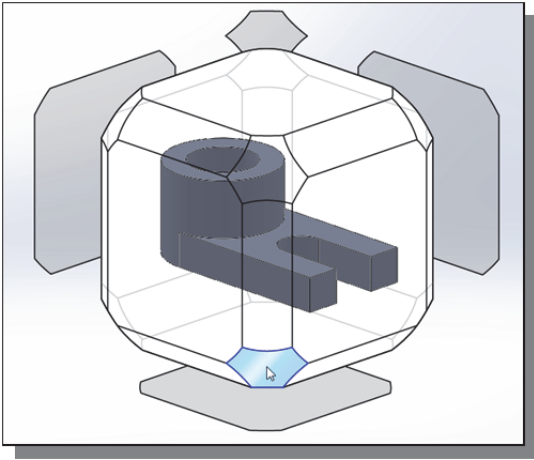

4. On your own, experiment with selecting other views using the *View Selector*. Notice that with the *View Selector* toggled **ON**, it automatically appears with the *View Orientation* option is selected on the *Heads-Up View* toolbar.

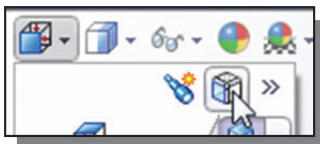

5. **Toggle** the View Selector **OFF** by left-clicking on the **View Selector** icon in the *Orientation dialog box*.

6. Hold down the **[Ctrl]** button and press the **[Spacebar]**. Notice the *View Selector* appears. This is an alternate method to activate the *View Selector*.

7. Select the isometric view as shown.

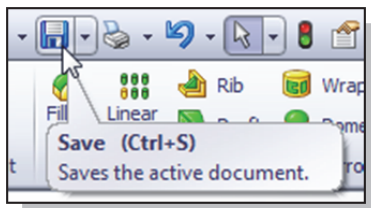
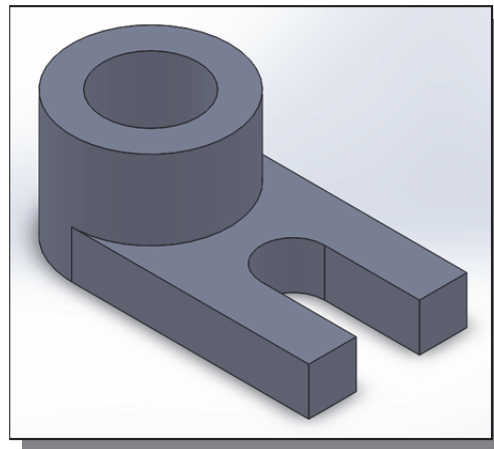
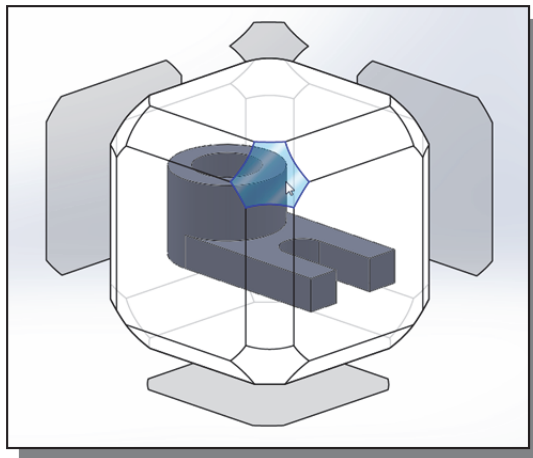

8. Save the model with the name *Locator*.

Questions:

1. List and describe three basic *Boolean operations* commonly used in computer geometric modeling software?
2. What is a *primitive solid*?
3. What does *CSG* stand for?
4. Which *Boolean operation* keeps only the volume common to the two solid objects?
5. What is the main difference between an *EXTRUDED CUT feature* and a *HOLE feature* in *SolidWorks*?
6. Using the CSG concepts, create *Binary Tree* sketches showing the steps you plan to use to create the two models shown on the next page:

Ex.1)

Ex.2)

Exercises: (All dimensions are in inches)

1.

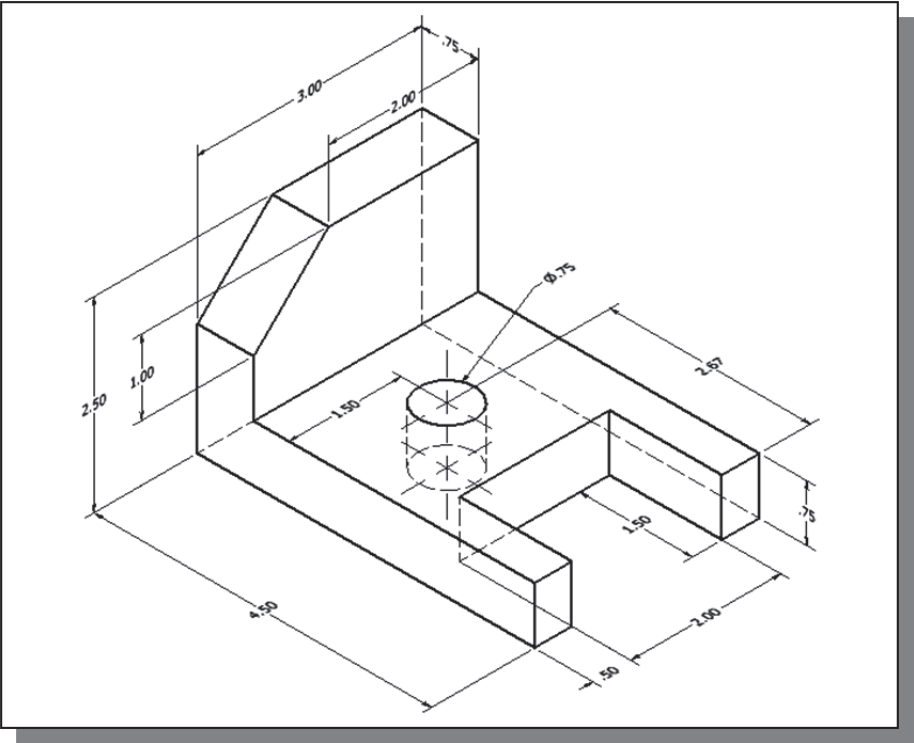

2.

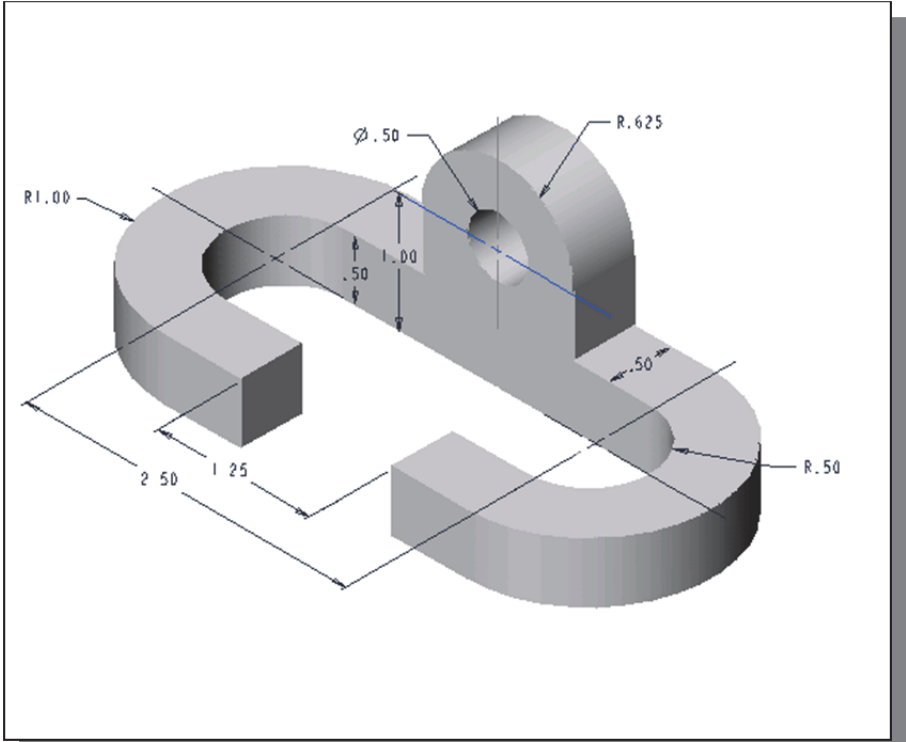

3.

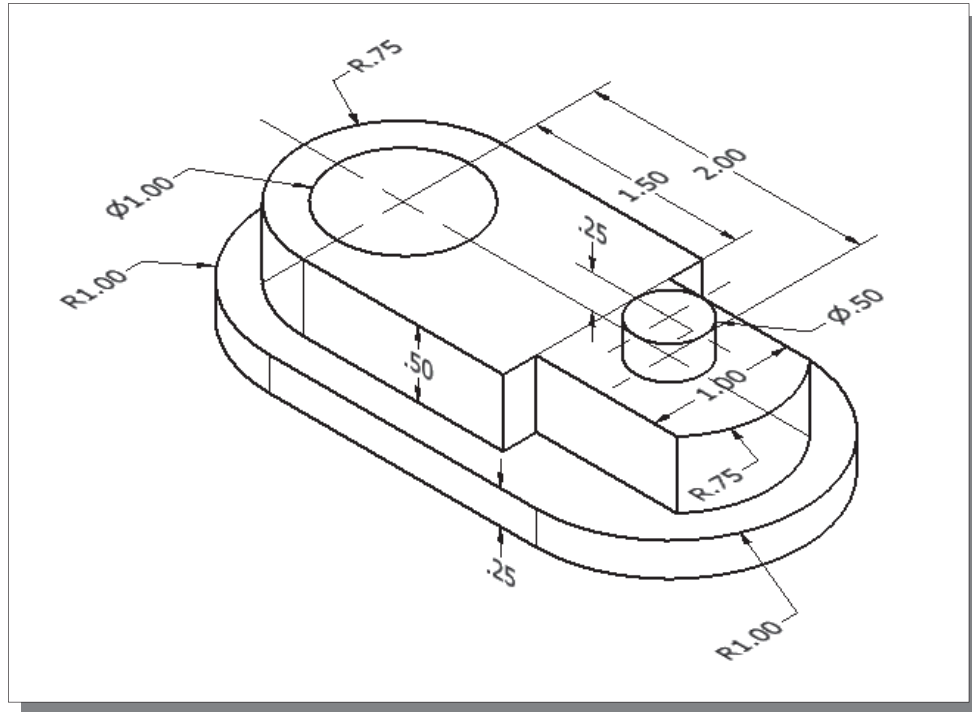

4.

