

Autodesk®

# AutoCAD® 2015 Fundamentals

Elise Moss



Visit the following websites to learn more about this book:



[amazon.com](https://www.amazon.com)

[Google books](https://books.google.com)

[BARNES & NOBLE](https://www.barnesandnoble.com)

## Lesson 3.0 – Drawing Lines

Estimated Class Time: **2 Hours**

---

### **Objectives**

This section introduces AutoCAD commands for creating a simple drawing. Starting with a New drawing, the user will learn to draw lines using different methods.

- **Start From Scratch**
  - Use the New command to begin a new drawing from “scratch”.
- **Line**
  - Draw line segments.
  - Using Direct Distance Method
  - Using Polar Tracking
  - Using Cartesian Coordinates
  - Absolute Coordinates
  - Relative Coordinates
  - Polar Coordinates
  - Drag Method
- **Coordinate Entry**
- **Erase**
  - Deleting AutoCAD entities
- **Constraints**
  - Managing Geometric Constraints

## Start from Scratch

### Command Locator

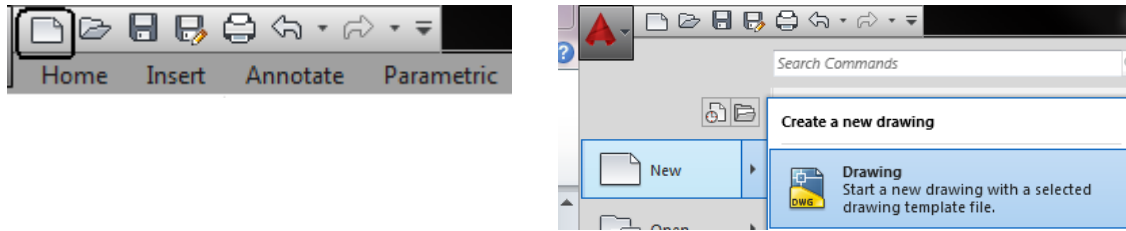

<i>Command</i>	<b>New</b>
<i>Alias</i>	<b>Ctrl+N</b>

For the exercises in this section, we will be using the *acad.dwt* template. This template setting was made when AutoCAD was installed. If you want to set a different default template to be used, go to the **Options** dialog and select the default template you wish to use.

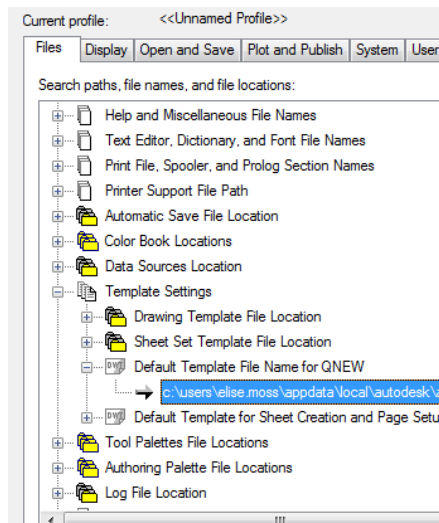

**The Options Dialog**

### Command Overview

To Create a New drawing, choose New. Every time the New drawing command is invoked, a new drawing is created with the title Drawing1, Drawing2, Drawing3, etc.

## General Procedures

1. Select the New button from the Standard Toolbar .



- Make it a habit to select the New file icon from the Quick Access Toolbar. This is a quicker way to access the command than from the Applications menu.
- Close drawings that are not being used.

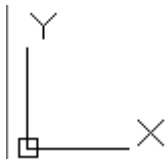

The graphics window uses a Cartesian coordinate system. The lower left corner of the screen shows a UCS (user coordinate system) icon. The icon shows x for horizontal and y for vertical. The z-axis is pointed toward the user. The UCS is located at the 0,0 or origin point.

1.6898, 14.1004, 0.0000 MODEL

In the middle of your screen, you will see some numbers. These numbers reflect the coordinate point (x, y) of your mouse. Move your mouse around and note how the coordinate values change.

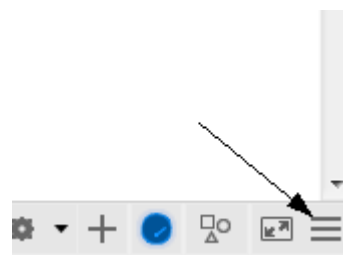
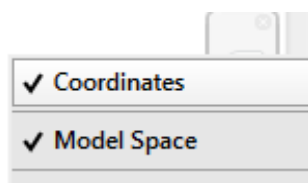

- To toggle the display of coordinates, left click on the Customize tool in the lower left of the screen and left click on Coordinates in the list.



Your graphics window in AutoCAD emulates a piece of paper. LIMITS controls the size of your piece of paper. When you start a new file, you can specify the size of paper you want to draw on using Wizards or Templates. AutoCAD really doesn't care where you draw in your graphics window. You can draw outside the limits with impunity.

AutoCAD allows you to draw geometry using four methods:

- Absolute Coordinates
- Relative Coordinates
- Polar Coordinates
- Direct Entry

Absolute Coordinates use absolute values relative to the origin.

Relative Coordinates use coordinates relative to the last point selected.

Polar Coordinates use a distance and angle relative to the last point selected.

Direct Entry allows the user to set ORTHO on (this is like using a ruler to draw a straight line), move the mouse in the desired direction, and then enter in the desired distance.

AutoCAD allows you to draw geometry using four methods:

- Absolute Coordinates
- Relative Coordinates
- Polar Coordinates
- Direct Entry

Absolute Coordinates use absolute values relative to the origin.

Relative Coordinates use coordinates relative to the last point selected.

Polar Coordinates use a distance and angle relative to the last point selected.

Direct Entry allows the user to set ORTHO on (this is like using a ruler to draw a straight line), move the mouse in the desired direction, and then enter in the desired distance.

There are two types of parametric constraints:

1. Geometric constraints control the shape of elements, such as lines and arcs, and their relationship to each other. For example, a horizontal constraint on a line ensures the line will be straight/orthogonal and parallel/coincident to the x-axis. A vertical constraint ensures a line will be straight/orthogonal and parallel/coincident to the y-axis. I tease my students that they should have paid better attention when they were studying geometry because all those geometric symbols - parallel, perpendicular, tangent - make an appearance and are used for geometric constraints.
2. Dimensional constraints control the distance, length, angle, and radius values of elements.

## Line

---

### Command Locator

---

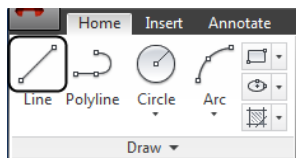

<i>Command</i>	<b>Line</b>
<i>Alias</i>	<b>L</b>

---

### Command Overview

.....

A line is defined by two endpoints. A line has 0 width and 0 thickness. When drawing a line, specify the first point, then specify the next point. Press the enter button on the mouse (with the cursor in the drawing window) to access the Line Shortcut menu. Type C to close two or more line segments. Use the LMB to pick the points.

.....

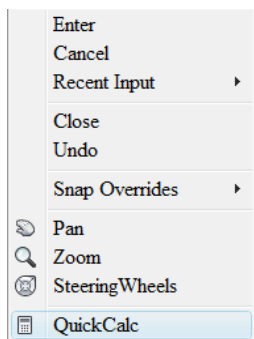

Line Shortcut Menu

Line Short-Cut Menu Option:	Overview
<b>Enter</b>	Select to exit the Line command.
<b>Cancel</b>	Cancels the command.
<b>Recent Input</b>	Lists the most recently entered point coordinates
<b>Close</b>	Closes the line to form a closed polygon.
<b>Undo</b>	Undoes the last segment of the line.
<b>Snap Overrides</b>	Allows the user to select a snap
<b>Pan</b>	Begins Real-Time Pan
<b>Zoom</b>	Begins Real-Time Zoom
<b>Steering Wheels</b>	Launches the Steering Wheel control
<b>QuickCalc</b>	Launches a calculator

## General Procedures

1. Begin the line command by selecting the line icon in the Draw panel on the ribbon or typing L at the blank command prompt.
2. Select the first point, select the next point, and continue selecting the endpoints of each successive line segment.
3. Press the <ENTER> button on the mouse (with the cursor in the drawing window), then select <ENTER> to end the Line command.
4. Press <ENTER> to Repeat the Line command.



- Move the mouse after selecting each endpoint of the line. This will make it easier to see the last line segment created.
- Double click on ORTHO in the Status Bar (or press F8) to alternate between drawing straight or angled line segments.
- Typing U for Undo in the middle of the line command will undo the last line segment. Typing U after completing line segments (at the blank command prompt) will Undo the entire line command.

## Command Exercise

### Exercise 3-1— Line using Direct Distance Method

Drawing Name: **Begin a new drawing**  
Estimated Time to Completion: 10 Minutes

#### Scope

Start a New drawing using the acad.dwt template. Enable DYN. With ORTHO on, draw the object below. Drag the line in the desired direction and type the distance. Do not add the dimensions.

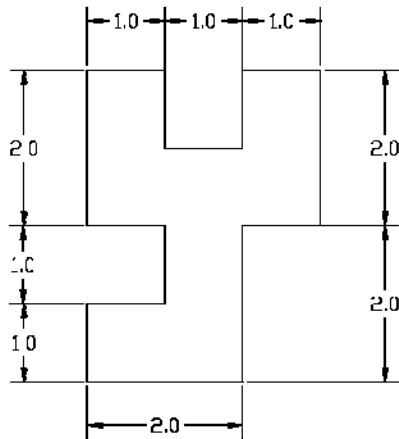

Line Exercise

#### Solution

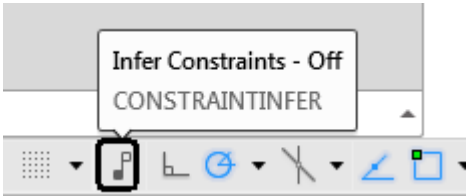
1. Turn **ORTHO** on by pressing <F8> until the command line says '<Ortho on>'.  

2. To see the geometric constraints as they are added, enable **Infer Constraints** or press **Ctrl+Shift+I**.

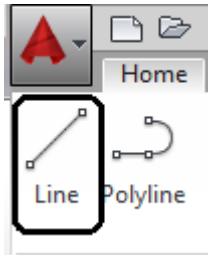
3. Invoke the **Line** command (l or line).  



- Specify next point or [Undo]:  
Type **2.5** for the X-coordinate.  
Use the **TAB** key to advance to the Y-coordinate square.  
Type **3.5** for the Y-coordinate. Press **<ENTER>**.

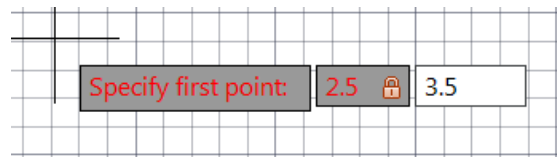

- Specify next point or [Undo]:  
Drag the cursor downward and type **2.00** and press **<ENTER>**.

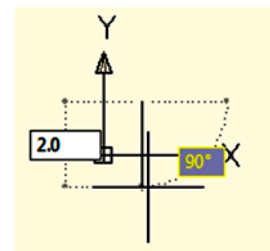

You will see a small icon next to the line. This is a geometric constraint.

A geometric constraint controls the geometry of an element. In this case, the symbol indicates that the line is vertical.



- Specify next point or [Undo]:  
Drag the cursor to the right and type **1.00** and press **<ENTER>**.

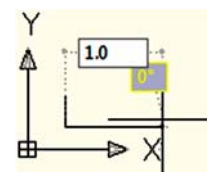

You should see another geometric constraint. This symbol indicates that the two lines are perpendicular to each other. Perpendicular means two lines form a 90° angle.



- Specify next point or [Close/Undo]:  
Drag the cursor downward and type **1.00** and press **<ENTER>**.

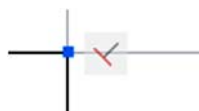
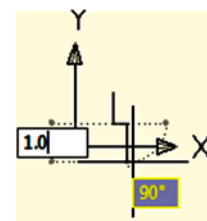

Another perpendicular symbol is added.

- Specify next point or [Close/Undo]:  
Drag the cursor to the left and type **1.00** and press **<ENTER>**.

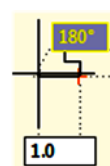

9. *Specify next point or [Close/Undo]:*  
Drag the cursor downward and type **1.00** and press <ENTER>.

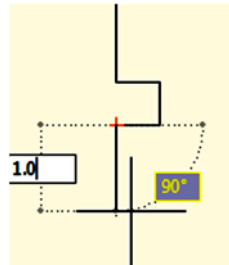

10. *Specify next point or [Close/Undo]:*  
Drag the cursor to the right and type **2.00** and press <ENTER>.

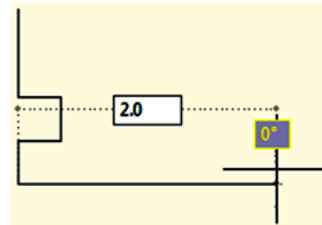

11. *Specify next point or [Close/Undo]:*  
Drag the cursor up and type **2.00** and press <ENTER>.

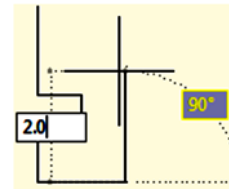

12. *Specify next point or [Close/Undo]:*  
Drag the cursor to the right and type **1.00** and press <ENTER>.

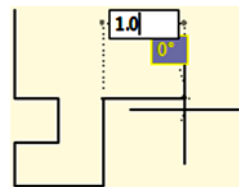

13. *Specify next point or [Close/Undo]:*  
Drag the cursor upward and type **2.00** and press <ENTER>.

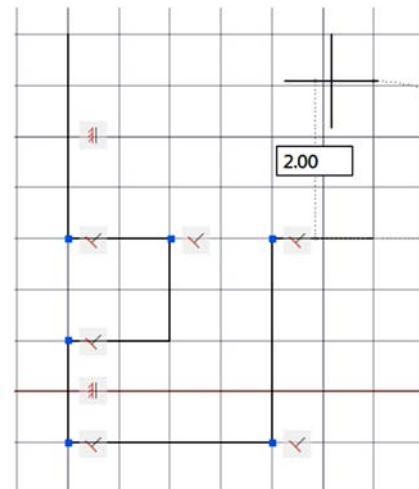

14. *Specify next point or [Close/Undo]:*  
Drag the cursor to the left and type **1.00** and press <ENTER>.

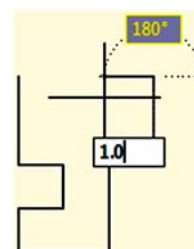

15. *Specify next point or [Close/Undo]:*

Drag the cursor downward and type **1.00** and press <ENTER>.

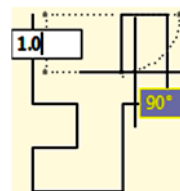

16. *Specify next point or [Close/Undo]:*

Drag the cursor to the left and type **1.00** and press <ENTER>.

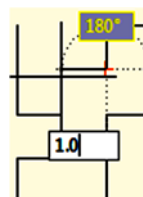

17. *Specify next point or [Close/Undo]:*

Drag the cursor upward and type **1.00** and press <ENTER>.

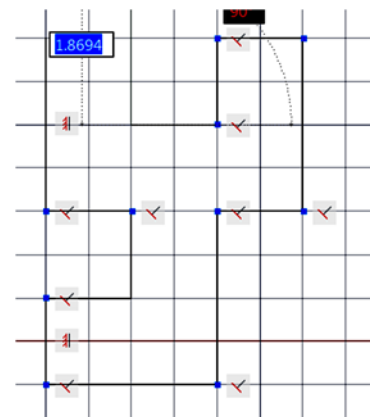
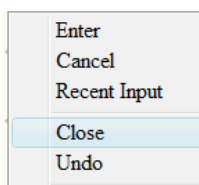

18. *Specify next point or [Close/Undo]:*

Right-click in the drawing area and select 'Close' or type 'C' and press <ENTER>.

*The Close command will only work if you created a continuous line. If you exited the line command and started again, then you have to manually close the figure.*

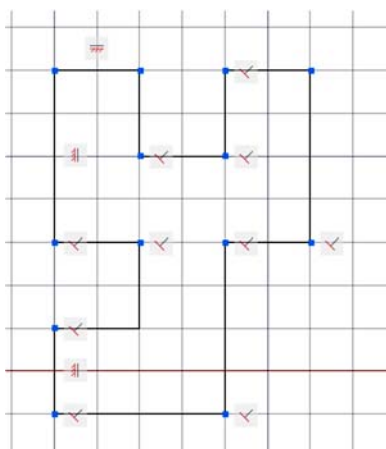

*Your completed figure should look like this.*

*See if you can identify the different geometric constraints. You should see constraint symbols for vertical, horizontal and perpendicular.*



*If the lines look crooked, then ORTHO is not on. You must begin again. Try to draw all of the line segments without starting and stopping the line command.*

*The Close option only works if you draw in one continuous line. Otherwise, you can simply draw a closing line from endpoint to endpoint.*

## Parametric Constraints

### Command Locator

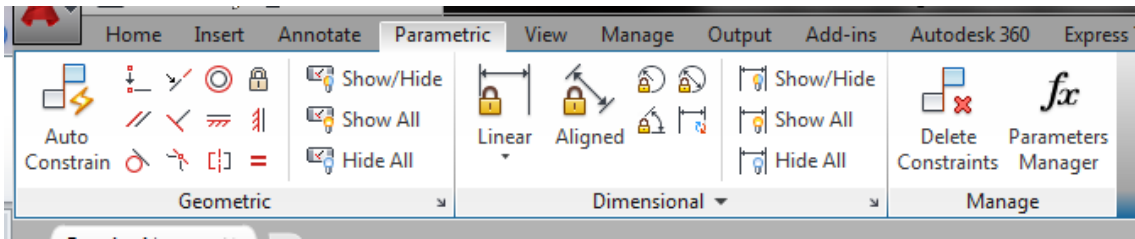

<i>Parametric Ribbon</i>	<b>Parametric</b>
<i>Command</i>	<b>Geomconstraint</b>

### Command Overview

To see the parametric constraints ribbon, you should have the Drafting & Annotation Workspace enabled.

### General Procedures

1. To apply a geometric constraint, select the type of geometric constraint desired, then select the element(s) to be constrained.



- Use inferred constraints - these are constraints which are automatically added as you draw.
- Hide geometric constraints when you are not actively constraining your sketch.
- Typing U for Undo in the middle of the line command will undo the last line segment. Typing U after completing line segments (at the blank command prompt) will Undo the entire line command.
- You can prevent constraints from automatically being applied by toggling OFF inferred constraints on the status bar or using the short-cut Ctl+Shift+I.

## Command Exercise

### Exercise 3-2 – Parametric Constraints

Drawing Name: **constraints1.dwg**

Estimated Time to Completion: 10 Minutes

#### Scope

Open 'constraints1.dwg.' Mouse over a constraint. Show all Constraints. Add a constraint. Delete a constraint. Hide all Constraints.

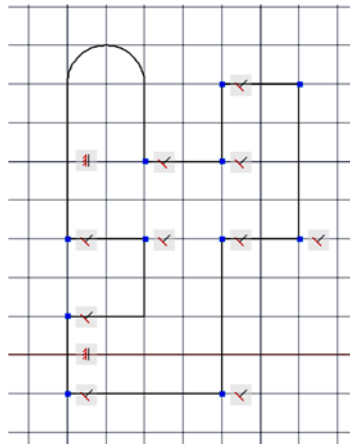

#### Solution

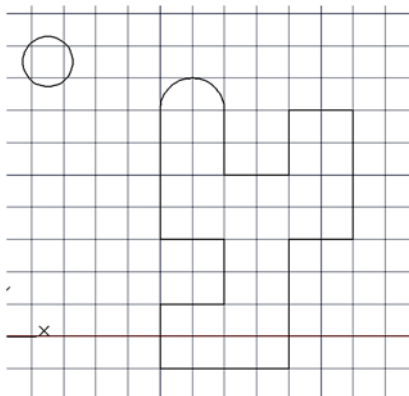

When the drawing is first opened, you should not see any geometric constraints.

The geometric constraints have been hidden. Their display has been turned OFF.

1. Mouse your cursor over the drawing WITHOUT selecting anything. Don't left click. As you mouse over the lines, you should see a small symbol. The symbol indicates that a geometric constraint exists for that line. If no geometric constraint exists, you will not see the symbol. Mouse over the small circle and notice that no symbol appears.

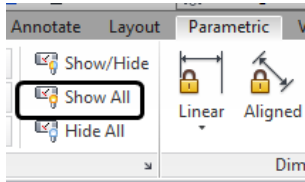

2. Activate the Parametric ribbon.
3. Select **Show All** to display all the geometric constraints currently applied.

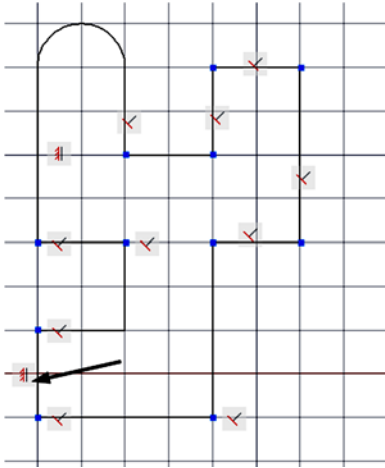

4. Use your left mouse button to re-arrange the geometric symbols.
5. Hold down the left mouse button and drag the symbol to a new position.

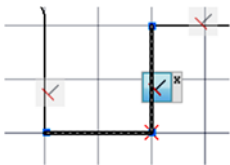

6. Press down with the left mouse button on one of the perpendicular symbols.

*Notice that it will display the two lines that are perpendicular.*

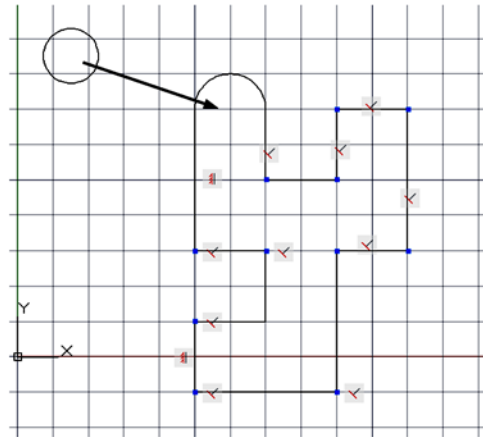

*Let's move the small circle so it is concentric to the arc using a geometric constraint.*

*A concentric constraint means that two or more arcs/circles share the same center point. The elements can have different radii.*

*When you apply a geometric constraint, the FIRST element remains fixed and the SECOND element moves to be constrained.*

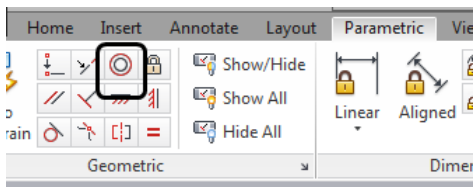

On the Parametric ribbon:

7. Select the **Concentric** constraint.

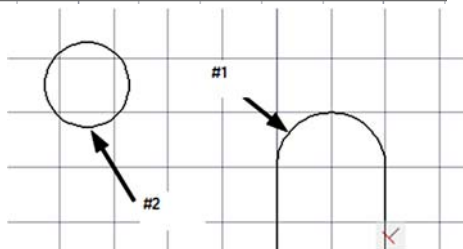

8. Select the arc first and then the circle.

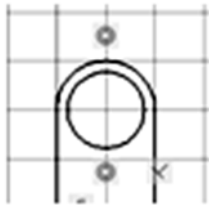

The circle popped into the correct position.

You also see the concentric symbol on the arc and the circle.

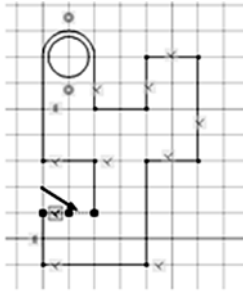

9. Select the line indicated.

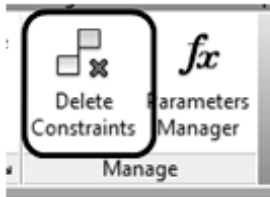

On the ribbon:

10. Select **Delete Constraints**.

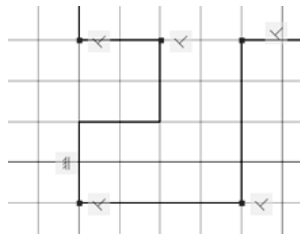

The perpendicular constraints on the selected line are deleted.

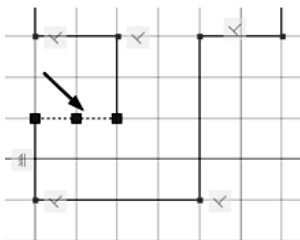

11. Select the same line.

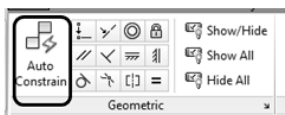

12. Select **Auto Constrain** from the ribbon.

This will add constraints to the selected line.

What constraints do you think will be added?

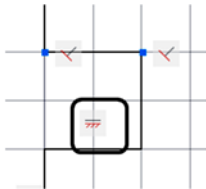

13. A horizontal constraint is added.

*In order to add a perpendicular constraint - you need to select TWO lines.*

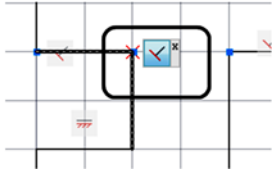

14. Select the perpendicular constraint.  
15. Select the small x in the symbol box.

*This hides the perpendicular constraint. It does not delete it.*

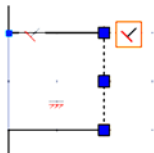

16. Select the vertical line.

*The perpendicular symbol will appear while the line is selected.*

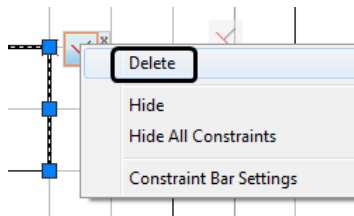

17. To delete the perpendicular constraint, select it, right click and select **Delete**.

18. *Press ESC to release the selection.*

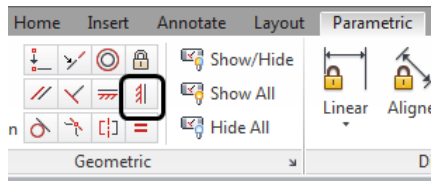

19. Select the vertical constraint.

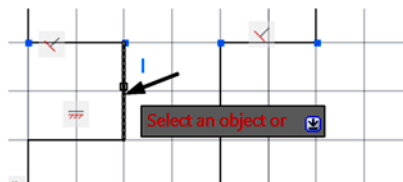

20. Select the vertical line.

*You see a vertical constraint has been applied.*

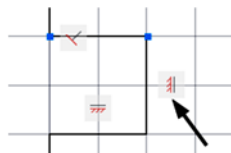

*You can only apply a vertical constraint if the perpendicular constraint has been removed. Too many geometric constraints on the same element is not allowed.*

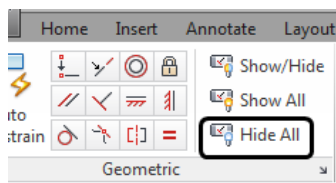

21. Select **Hide All**.

*This hides all the geometric constraints.*

22. Close without saving.



## Command Exercise

### Exercise 3-3 – Line Using Polar Tracking

Drawing Name: **Line2.dwg**

Estimated Time to Completion: 10 Minutes

#### Scope

Open 'line2.dwg' and draw the object shown in the example using the line command with POLAR enabled. Polar settings have already been made to create the necessary angles. When you have completed the third segment, type C to close the object. Press <ENTER> to repeat the line command, press <ENTER> again, and see that the line picks up from the last point selected.



#### Solution

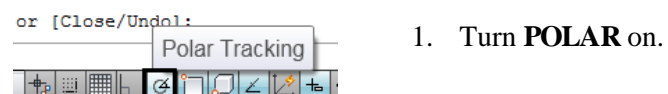

1. Turn **POLAR** on.

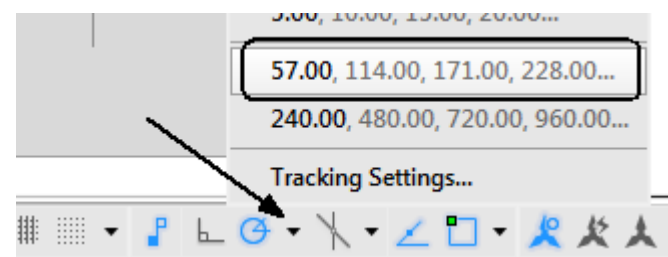

2. Left click on the down arrow next to the Polar Tracking icon.

3. Enable the 57.00 polar values.



4. Invoke the **Line** command (l or line).

5. *Specify first point:*

Pick a start point of the line with your left mouse button near the #1 on the drawing.

6. *Specify next point or [Undo]:*

Pick a second point near the #2 on the drawing.

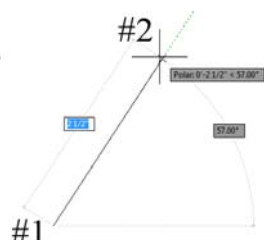

As you draw your line up to the #2, look for the Tooltip indicating the 57-degree angle.



7. *Specify next point or [Undo]:*  
Move your mouse near #3 and click to complete the second line segment.

As you draw your line up to the #3, look for the Tooltip indicating the 0-degree angle.

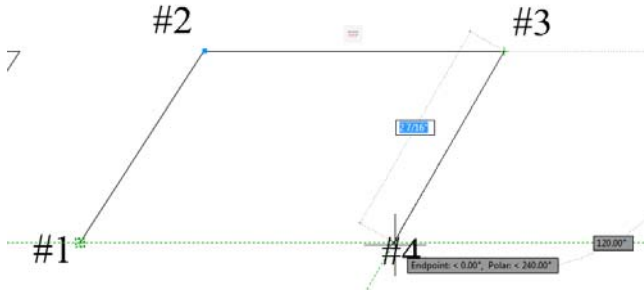

8. *Specify next point or [Close/Undo]:*  
Use Object Tracking to line up your end point and set the Polar Angle to 240-degrees.
9. *Specify next point or [Close/Undo]:*  
Right-click in the drawing area and select **Close** or type 'C' or 'CLOSE' and press <ENTER> at the command line to create the final line segment.



- 
- When you closed your object did it complete the parallelogram? If not, you may have stopped and restarted the line sequence, in which case the close option will refer to the new start point.
  - Move your mouse, as you work to see what line segments you have just completed.
  - Click on ORTHO in the Status bar, or press the <F8> function key; whichever is more convenient at the time; to create straight lines.
  - Make a habit of using the <ENTER> key to complete your AutoCAD commands, and to repeat the last command used. Alternately, you may click the right mouse button and select the Repeat option.
  - In order for Polar Tracking to click to specific angle values, you have to have them set. Use Settings in the Polar Tracking dialog to add angles you want to use in your drafting.
-

---

## Command Exercise

### *Exercise 3-4 – Line Using Cartesian Coordinates*

---

Drawing Name: **Begin a new drawing**

Estimated Time to Completion: 10 Minutes

#### Scope

*Start a New Drawing using the acad.dwt template and draw the object shown in the example using the line command with Cartesian Coordinates. When you have completed the third segment, type C to close the object. Press <ENTER> to repeat the line command, press <ENTER> again, and see that the line picks up from the last point selected. Turn DYN off and ORTHO on for this exercise.*

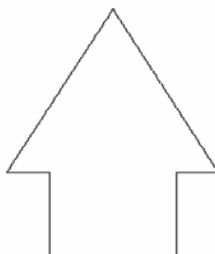

#### Solution

1. Invoke the **Line** command (l or line).



2. *Specify first point:* Type **0,0** at the command line.
3. *Specify next point or [Undo]:* Type **3,0**.
4. *Specify next point or [Undo]:* **3,2**
5. *Specify next point or [Close/Undo]:* **4,2**
6. *Specify next point or [Close/Undo]:* **1.5,6**
7. *Specify next point or [Close/Undo]:* **-1,2**
8. *Specify next point or [Close/Undo]:* **0,2**
9. *Specify next point or [Close/Undo]:*  
Right-click in the drawing area and select 'Close' or type 'C' or 'CLOSE' and press <ENTER> at the command line to create the final line segment.



- If your drawing did not turn out properly, make sure you had **DYN OFF**. To check your data entry, press **F2** and the text window will open and you can review your entries.

## Coordinate Entry

### Command Overview

Once the Units have been established, coordinates can be typed to specify points or distances. Always draw full scale. There are four ways to specify coordinates: absolute, relative, polar, and direct distance.

<i>Coordinate Entry Method</i>	<i>Overview</i>	<i>Examples</i>
<b>Absolute Coordinates</b>	The x and y coordinates are determined by an absolute Origin point of 0,0.	X,Y
<b>Relative Coordinates</b>	The x and y coordinates reference the last point selected in the drawing.	@x,y @3,5
<b>Polar Coordinates</b>	The distance and angle specified references the last point selected in the drawing	@distance<angle @5<45
<b>Direct Distance</b>	Select the first point, then drag the cursor in the desired direction and type the distance.	Type the distance 4

## General Procedures

### Using Absolute Coordinates:

1. When prompted to specify a point, type the Absolute coordinates for x and y (x,y)
  2. Type the Absolute Coordinate for each successive point (x,y).
- Typical Example: Inserting a Title Block or an Externally Referenced Drawing at a specific location.*

### Using Relative Coordinates:

1. When prompted to specify a point, select a point in the drawing.
  2. Type the Relative Coordinate for each successive point (@x,y).
- Typical Example: Drawing a Rectangle.*

### Using Polar Coordinates:

1. When prompted to specify a point, select a point in the drawing.
  2. Type the Polar Coordinate for each successive point (@distance < angle).
- Typical Example: Drawing lines or moving objects at a specified distance and angle other than orthogonal angles.*

### Using Direct Distance:

1. When prompted to specify a point, select a point in the drawing.
  2. Turn ORTHO on and drag the cursor in the desired direction.
  3. Type the distance and press <ENTER>.
- Typical Example: Drawing lines or using the Move, Copy or Stretch commands.*



- 
- Always use object snap for selecting specific points in the drawing.
  - Remember to separate the x and y coordinates by a comma. Example: 1,5 means the absolute coordinate where x=1 and y=5.
  - It is not necessary to type the z coordinate when z = 0.
  - Angles are typically measured counter-clockwise. Angle 0 is typically East.
  - Precede Relative and Polar coordinate information with an @ sign (over the number 2 on the keyboard).
  - ORTHO should be on when using the direct distance method.
  - When drawing lines, or moving objects at specific angles (other than with ORTHO on), type the polar coordinate (example: @10<45) or use Polar Tracking Settings.
  - Typing the minimum number of keystrokes is important for drawing efficiently. AutoCAD will fill in leading and trailing zeros and the appropriate Unit endings.
  - AutoCAD will convert decimal equivalents to feet and inches.
  - AutoCAD will assume inches, unless the foot mark ' is typed.
  - The Coordinates Display can be turned on or off from the Status Bar by double clicking on it (LMB). If in the middle of a Draw or Modify command, a third option will display the distance and <angle.
  - The DYN toggle can be used to display and enter coordinates
-

---

---

## Command Exercise

---

### ***Exercise 3-5 – Absolute Coordinates***

---

Drawing Name: **entry1.dwg**

Estimated Time to Completion: 5 Minutes

#### **Scope**

Start the line command. Draw the objects using the absolute coordinates in the order indicated. Connect the points using only the keyboard. Turn *DYN* off and *ORTHO* on.

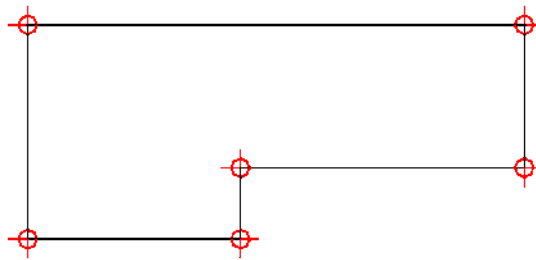

#### **Solution**



Line

1. Invoke the **Line** command (l or line).
2. *Specify first point:*  
Type **1,1** at the command line and press <ENTER>. Notice where the first point of the line is created.
3. *Specify next point or [Undo]:*  
Type **4,1** at the command line and press <ENTER>.
4. *Specify next point or [Undo]:*  
Type **4,2** at the command line and press <ENTER>.
5. *Specify next point or [Close/Undo]:*  
Type **8,2** and press <ENTER>.
6. *Specify next point or [Close/Undo]:*  
Type **8,4** and press <ENTER>.
7. *Specify next point or [Close/Undo]:*  
Type **1,4** and press <ENTER>.
8. *Specify next point or [Close/Undo]:*
9. Type **1,1** and press <ENTER>.
10. *Specify next point or [Close/Undo]:*  
Press the <ENTER> key to end the command.



- You can also use the close option to complete the exercise rather than typing in the final '1,1'.

## Command Exercise

### Exercise 3-6 – Relative Coordinates

Drawing Name: **entry2.dwg**

Estimated Time to Completion: 5 Minutes

#### Scope

Start the line command. Draw the objects using the relative coordinates in the order indicated. Connect the points using only the keyboard

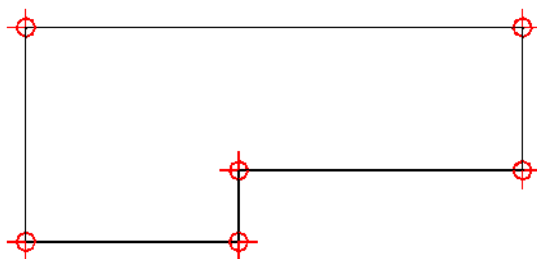

#### Solution

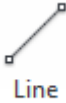
1.  Invoke the **Line** command (l or line).
2. *Specify first point:*  
Type **1,1** at the command line and press <ENTER>.
 

Notice where the first point of the line is created.
3. *Specify next point or [Undo]:*  
Type **@3,0** at the command line and press <ENTER>.
4. *Specify next point or [Undo]:*  
Type **@0,1** at the command line and press <ENTER>.
5. *Specify next point or [Close/Undo]:*  
Type **@4,0** and press <ENTER>.
6. *Specify next point or [Close/Undo]:*  
Type **@0,2** and press <ENTER>.
7. *Specify next point or [Close/Undo]:*  
Type **@-7,0** and press <ENTER>.
8. *Specify next point or [Close/Undo]:*  
Type **@0,-3** and press <ENTER>.
9. *Specify next point or [Close/Undo]:*  
Press the <ENTER> key to end the command.

**Extra:** What would you type in to create the shape in a clockwise fashion instead of counter clockwise direction? Try It.

## Command Exercise

### Exercise 3-7 – Polar Coordinates

---

Drawing Name: **entry3.dwg**

Estimated Time to Completion: 5 Minutes

#### Scope

Start the line command. Draw the objects using polar coordinates in the order indicated. Connect the points using only the keyboard

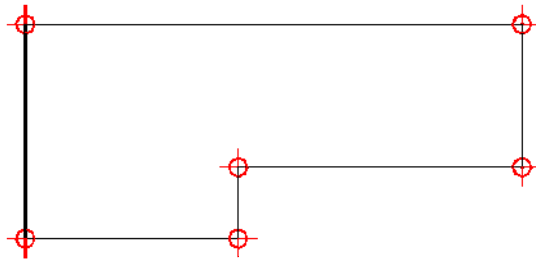

#### Solution

-  1. Invoke the **Line** command (l or line).  
Line
2. *Specify first point:*  
Type **1,1** at the command line and press <ENTER>.  
Notice where the first point of the line is created.
3. *Specify next point or [Undo]:*  
Type **@3<0** at the command line and press <ENTER>.
4. *Specify next point or [Undo]:*  
Type **@1<90** at the command line and press <ENTER>.
5. *Specify next point or [Close/Undo]:*  
Type **@4<0** and press <ENTER>.
6. *Specify next point or [Close/Undo]:*  
Type **@2<90** and press <ENTER>.
7. *Specify next point or [Close/Undo]:*  
Type **@7<180** and press <ENTER>.
8. *Specify next point or [Close/Undo]:*  
Type **@3<270** and press <ENTER>.
9. *Specify next point or [Close/Undo]:*  
Press the <ENTER> key to end the command.

---

**Extra:** What would happen if you typed @-3<180 in step 3 in the exercise? Try it.

---



## Command Exercise

### Exercise 3-8 – Drag Method

Drawing Name: **entry4.dwg**

Estimated Time to Completion: 5 Minutes

#### Scope

*Start the line command. Draw the objects using the direct distance method.*

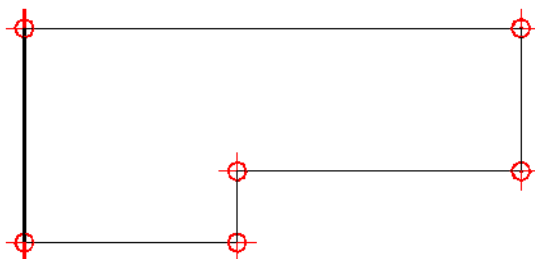

#### Solution

1.  Invoke the **Line** command (l or line).
2. *Specify first point:*  
Type **1,1** at the command line and press <ENTER>.
 

Notice where the first point of the line is created.
3. *Specify next point or [Undo]:*  
Toggle ORTHO ON at the Status bar.
4. *Specify next point or [Undo]:*  
Drag the mouse to the right, type **3** and press <ENTER>.
5. *Specify next point or [Close/Undo]:*  
Drag the mouse upward, type **1** and press <ENTER>.
6. *Specify next point or [Close/Undo]:*  
Drag the mouse to the right, type **4** and press <ENTER>.
7. *Specify next point or [Close/Undo]:*  
Drag the mouse upward, type **2** and press <ENTER>.
8. *Specify next point or [Close/Undo]:*  
Drag the mouse to the left, type **7** and press <ENTER>.
9. *Specify next point or [Close/Undo]:*  
Drag the mouse downward, type **3** and press <ENTER>.
10. *Specify next point or [Close/Undo]:*  
Press the <ENTER> key to end the command.

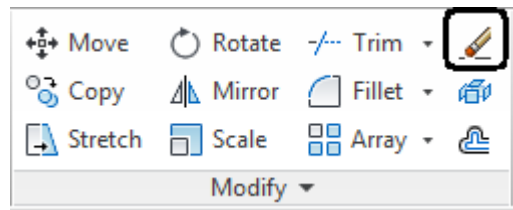
**Erase****Command Locator**

<i>Home/Modify Panel</i>	<b>Erase</b>
<i>Command</i>	<b>Erase</b>
<i>Alias</i>	<b>E</b>

**Command Overview**

Erase deletes selected objects. Press <ENTER> after selecting the objects to erase to execute the command. Type OOPS to bring back the last set of erased objects, even if other objects were drawn since the last erase.

General Procedures

1. Begin the erase command by selecting the Erase icon from the Modify Toolbar/Ribbon or typing E at the blank command prompt.
2. Place the cursor over the objects to erase and pick (LMB).



- If the cursor is not over an object, a selection window will appear. Make the other corner of the selection window.
- A Selection Window made from Left to Right will select only the objects completely in the window. *This is called a selection window.*
- A Selection Window made from Right to Left will select all objects the window crosses. *This is called a selection crossing.*
- Typing All (and pressing <ENTER>) will select all objects in the drawing to erase. Press <ENTER> to execute the command.

## Command Exercise

### Exercise 3-9 – Erase

Drawing Name: **erase1.dwg**

Estimated Time to Completion: 5 Minutes

#### Scope

*Erase the objects in the drawing. Draw some more lines. Type OOPS to bring back the last set of erased objects.*

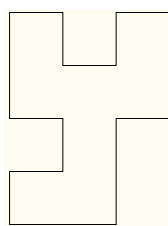

#### Solution

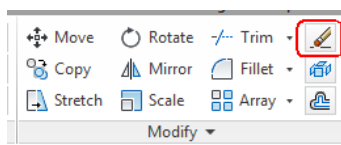

1. Invoke the **Erase** command (e or erase).

2. *Select objects:*

Select the objects by typing **ALL** and pressing <ENTER>, picking each line individually, or using the Window method. When all the objects are highlighted, press <ENTER> to execute the Erase command.

3. Invoke the **Line** command (l or line).



4. *Specify first point:*

Use your LMB to pick the start point of a line segment. Select any location on the drawing.

5. *Specify next point or [Undo]:*

Continue to use the LMB to create lines on the drawing.

6. *Specify next point or [Close/Undo]:*

Press the <ENTER> key to end the line command.

7. Type **OOPS** at the command line and press the <ENTER> key.



- *Select all the objects to erase, then press <ENTER> to execute the command. To remove an object from the selection set, hold down the shift key and select the object again. See that it is removed from the selection set. Then press <ENTER>.*

## **Review Questions**

1. How do you turn on the display of the coordinates in the status bar?
2. A user enters LINE 1,1 and then @0,2 ...what type of coordinates is she using?
3. To make sure you will always draw a straight line, what tray button should be enabled?
4. When using the POLAR method of coordinate entry, which tray button should be enabled?
5. When entering direct coordinates, which tray button should be disabled?
6. What is the difference between OOPS and UNDO?

## Review Answers

1. How do you turn on the display of the coordinates in the status bar?  
*Left click on the STATUS bar options icon and enable Coordinates*
2. A user enters LINE 1,1 and then @0,2 ....what type of coordinates is she using?  
*Relative*
3. To make sure you will always draw a straight line, what tray button should be enabled?  
*ORTHO*
4. When using the POLAR method of coordinate entry, which tray button should be enabled?  
*POLAR*
5. When entering direct coordinates, which tray button should be disabled?  
*DYN*
6. What is the difference between OOPS and UNDO?  
*UNDO reverses the last command entered. OOPS restores the last item(s) erased or deleted from the drawing.*