

Technical Drawing 101 with AutoCAD® 2015

A Multidisciplinary Curriculum for the First Semester



Douglas Smith
Antonio Ramirez
Jana Schmidt



Better Textbooks. Lower Prices.
www.SDCpublications.com

Visit the following websites to learn more about this book:



[amazon.com](https://www.amazon.com)

[Google books](https://books.google.com)

[BARNES & NOBLE](https://www.barnesandnoble.com)

TECHNICAL DRAWING

OBJECTIVES

After studying the material in this chapter, you should be able to:

1. Explain what technical drawings are.
2. Explain the terminology used to describe the process of creating technical drawings.
3. Explain how technical drawings are produced.
4. Explain the training needed to become an engineer, architect, designer, or drafter.
5. Describe the process of obtaining employment in the technical drawing field and the qualities that employers seek.
6. Describe what career prospects and opportunities, including salary ranges, are available in the field of technical drawing.

CHAPTER ONE

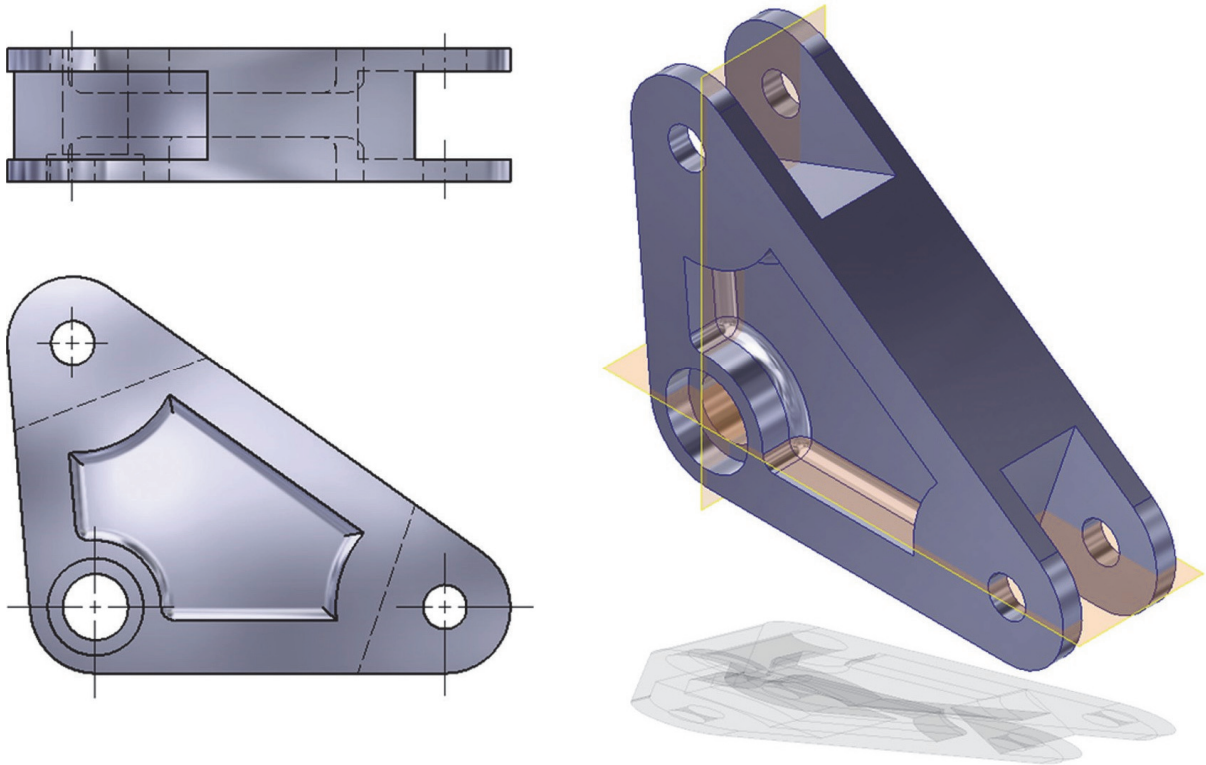

OVERVIEW

Technical drawings are the graphics and documentation (including notes and specifications) used by manufacturers to fabricate electronic and mechanical products and by construction professionals to produce houses, commercial buildings, roads, bridges, and water and wastewater systems. In fact, technical graphics are produced before almost all products are manufactured—from the electronic devices inside your cell phone to the handle of your toothbrush.

Refer to the following websites:

- American Design Drafting Association: www.adda.org
- American Institute of Architects: www.aia.org
- American Society for Engineering Education: www.asee.org
- National Society of Professional Engineers: www.nspe.org
- U.S. Department of Labor: www.bls.gov

1.1 THE ORIGINS OF TECHNICAL DRAWING

Technical drawing is not a new concept; archeological evidence suggests that humans first began creating crude technical drawings several thousand years ago. Through the ages, architects and designers, including Leonardo Da Vinci, created technical drawings. However, a French mathematician, Gaspard Monge, is considered by many to be the founder of modern technical drawing. Monge's thoughts on the subject, *Géométrie Descriptive* (Descriptive Geometry), published around 1799, became the basis for the first university courses. In 1821, the first English-language text on technical drawing *Treatise on Descriptive Geometry*, was published by Claudius Crozet, a professor at the U.S. Military Academy. Other terms often used to describe the creation of technical drawings are *drafting*, *engineering graphics*, *engineering drawings*, and *computer-aided design (CAD)*.

1.2 THE ROLE OF TECHNICAL DRAWING IN THE DESIGN PROCESS

To appreciate technical drawing's role in the design process, you must first understand some basics about design process itself. For most projects, the first phase of a design project is to define clearly the design criteria that the finished design must meet to be considered a success. Many designers refer to this phase in the design process as problem identification. For example, before designing a house, an architectural designer needs to know the size and style of home the client wants, the number of bedrooms and baths, and the approximate budget for the project. The designer also needs information about the site where the house will be built. Is it hilly or flat? Are there trees, and if so, where are they located? What is the orientation of the site relative to the rising and setting of the sun? These concerns represent just a few of many design parameters that the designer needs to define before beginning the design process.

Once the design problem is clearly defined, the designer begins preparing preliminary designs that can meet the parameters defined during the problem identification phase. During this step, multiple solutions to the design problem may be generated in the form of freehand sketches, formal CAD drawings, or even rendered three-dimensional (3D) models. Designers refer to this process of generating many possible solutions to the design problem as the ideation, or brainstorming, phase of the process.

The preliminary designs are shown to the client to determine whether the design is in line with the client's expectations. This step allows the designer to clarify the client's needs and expectations. It also is an opportunity for a designer to educate the client about other, possibly better, solutions to the design problem.

After the client decides on a preliminary design that meets the criteria established in the first problem identification phase, the designer begins preparing design inputs that more clearly define the details of the design project. Design inputs may include freehand sketches with dimensional information, detailed notes, or even CAD models. Figure 1.1 shows an example of an architectural designer's sketch of a foundation detail for a house.

When the design inputs are finished, they are given to the drafter(s) responsible for preparing the technical drawings for the project. *Drafters* are individuals who have received specialized training in the creation of technical drawings.

One of the most important skills that drafters must acquire during their training is the ability to interpret design inputs and transform them into technical drawings. Drafters usually work closely with other members of the design team, which may include designers, checkers, engineers, architects, and other drafters during the creation of technical drawings. CAD software can range in price from several hundred to thousands of dollars per station depending on the software. Figure 1.2 shows an AutoCAD drawing prepared from the designer's sketch shown in Figure 1.1.

Most drafters use CAD software to prepare the drawings. CAD allows drafters to produce drawings much more quickly than traditional drafting techniques. Popular CAD programs include AutoCAD®, Revit®, Autodesk® Inventor®, SolidWorks®, and Pro/ENGINEER®.

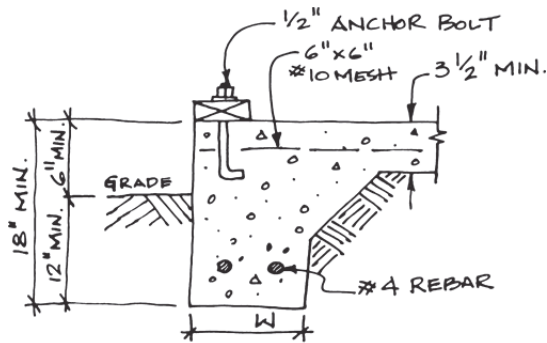

1.1 Architectural Designer's Sketch of a Foundation Detail

- MONOLITHIC SLAB DETAIL WITH INTEGRAL FOOTING
- 1.) TWO #4 REBAR @ 4" O.C.
 - 2.) 6" X 6" - #10 MESH IN FLOOR SLAB
 - 3.) 1/2" ANCHOR BOLTS @ 6'-0" O.C.
 - 4.) FOOTING WIDTH, W = 10" MIN.

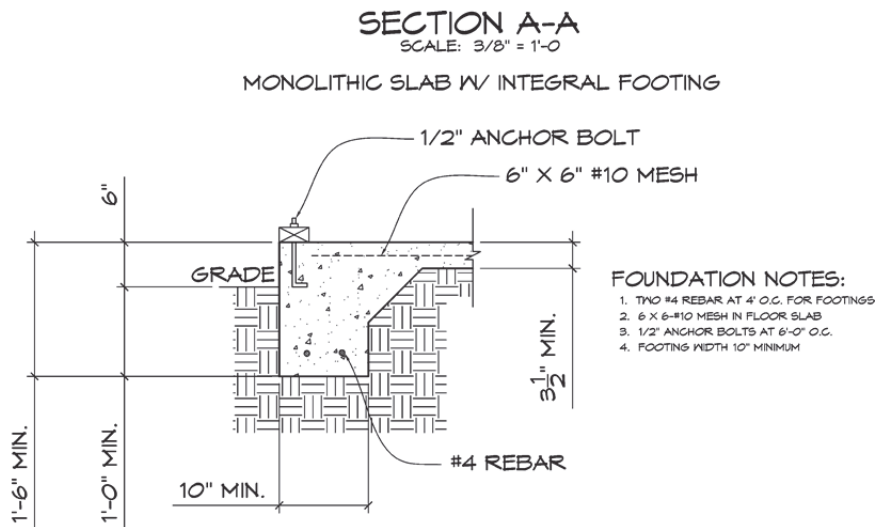

1.2 Detail Prepared from Architectural Designer's Sketch in Figure 1.1

JOB SKILLS

Although modern drafters use CAD tools to create drawings, traditional drafting skills such as sketching and blueprint reading are still very important for facilitating communication between drafters and designers.

When the drafter is finished preparing the technical drawings, the designer, or in some cases a checker, reviews the drawings carefully for mistakes. If mistakes are found, or if the design has been revised, the drafter will make the necessary corrections or revisions to the drawings. This process is repeated until the construction drawings are considered to be complete. When the entire set of construction drawings is finalized, the drafter and designer(s) put their initials in an area of the drawing called the title block.

The finished construction drawings represent the master plan for the project. Everything required to complete the project, from applying for a building permit to securing financing for the project, revolves around the construction drawings. Building contractors use the construction documents to prepare bids for the project, and the winning bidders will use them to construct the building.

Engineering designers follow a similar process when designing products. Most engineering projects begin with a definition of initial design criteria and progress through the phases of preliminary design, design refinement, preparation of technical drawings, manufacturing, and inspection.

The trend in modern design, whether architectural or engineering, is to use CAD tools to create a dynamic, often three-dimensional, database that can be shared by all members of the design team. Increasingly, others in the organization, such as those involved in marketing, finance, or service and repair, will access information from the CAD database to accomplish their jobs.

JOB SKILLS

Catching problems and mistakes during the design and drafting stages of the project can result in huge savings versus correcting mistakes on the job site or after the project has been built or manufactured. An example is the enormous cost incurred by an automobile manufacturer who has to recall thousands of cars to correct a design problem versus the cost of catching the problem on the technical drawing before the cars are manufactured.

1.3 TRAINING FOR CAREERS IN TECHNICAL DRAWING

Most drafters acquire their training by attending community college or technical school programs that lead to a certificate or associate's degree in drafting and design or CAD. These programs usually take from one to two years to complete and focus on the skills necessary to work as a drafter in industry, such as drafting techniques, knowledge of drafting standards, and the use of CAD programs to create drawings. Although most employers do not require that drafters be certified, the American Design Drafting Association (ADDA) has established a certification program for drafters. Individuals seeking certification must pass a test, which is administered periodically at ADDA-authorized sites. Some publishers of CAD software also offer certification on their products through authorized training sites.

Most drafters are full-time employees of architectural and engineering firms. Usually, drafters qualify for overtime pay when they work in excess of 40 hours per week. However, some drafters prefer to work as nonemployee contractors. Contractors are usually very experienced drafters who often earn higher salaries than direct employees but have less job stability. Some organizations allow drafters to telecommute and transfer drawing files to the office via the Internet. *Designers* are often former drafters who have proven their ability to take on more responsibility and decision-making duties. Designers usually earn higher salaries than drafters because they are charged with more responsibility for the design, and even the successful completion, of the project.

To become an engineer or architect, an individual must first earn a bachelor's degree in engineering or architecture from a university program. Bachelor's degree programs generally take four to five years to complete and usually require a mastery of higher level courses in mathematics and physics.

After earning a degree, an engineer may become a *professional engineer (P.E.)*, and an architect may become licensed, through a process involving both work experience and strenuous professional exams. The accreditation of architects is regulated by the American Institute of Architects (AIA) and by individual state statutes. The accrediting agency for engineers is the *National Society of Professional Engineers*.

TIP

You can learn more about the American Design Drafting Association by visiting its website at www.adda.org. You can learn more about the American Institute of Architects and the National Society of Professional Engineers by visiting their websites at www.aia.org and www.nspe.org, respectively.

Career Paths in Technical Drawing

Architectural drafters work with architects and designers to prepare the drawings used in construction projects. These drawings may include floor plans, elevations, and construction details. Study of construction techniques and materials, as well as building codes, is important to the education of an architectural drafter. Some architectural drafters specialize in residential architecture (houses), whereas others may specialize in commercial architecture (buildings and apartments) or structural drafting (steel buildings or concrete structures). Figures 1.3 and 1.4 show details from a set of architectural drawings prepared by an architectural design drafter using Autodesk® Revit® CAD software.

Mechanical drafters work with mechanical engineers and designers to prepare detail and assembly drawings of machinery and mechanical devices. Mechanical drafters are usually trained in basic engineering theory as well as drafting standards and manufacturing techniques. They may be responsible for specifying items on a drawing such as the types of fasteners (nuts, bolts, and screws) needed to assemble a mechanical device or the fit between mating parts. Figure 1.5 shows a 3D model of a bellcrank created with Autodesk® Inventor® CAD software.

Aeronautical or aerospace drafters prepare technical drawings used in the manufacture of spacecraft and aircraft. These drafters often split their duties between mechanical drafting and electrical/electronic drafting and are sometimes referred to as *electro/mechanical drafters*.

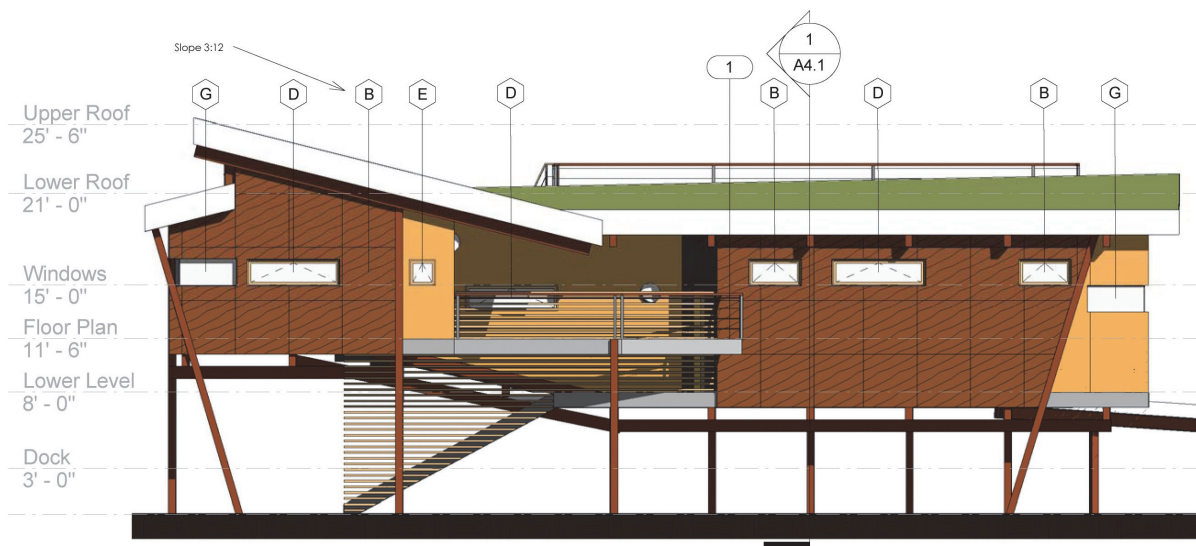

1.3 Elevation View of a Custom Home Created with 3D Modeling Software.

Source: Image courtesy David Naumann.

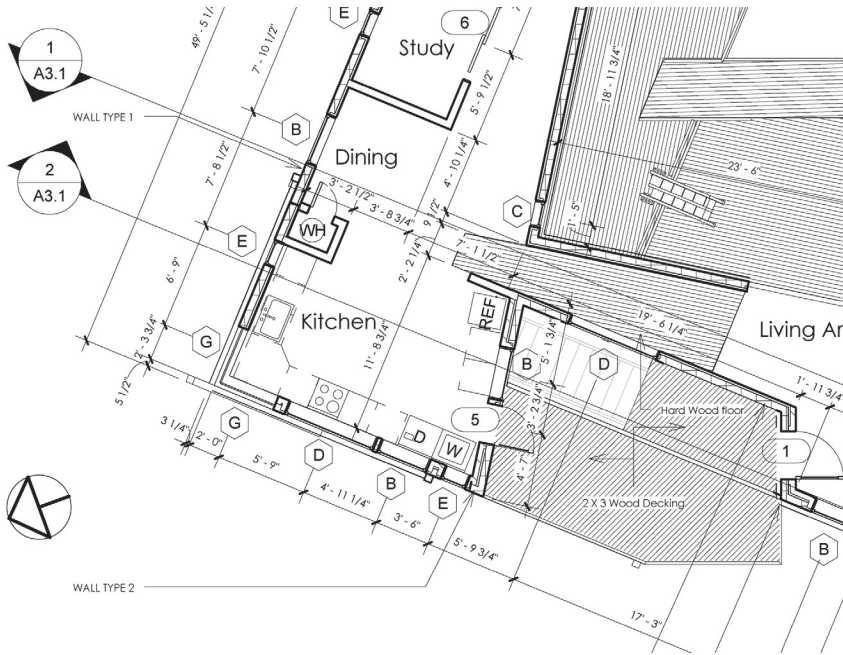

1.4 Detail from the Floor Plan of the Home Shown in Figure 1.3.
Source: Image courtesy David Naumann.

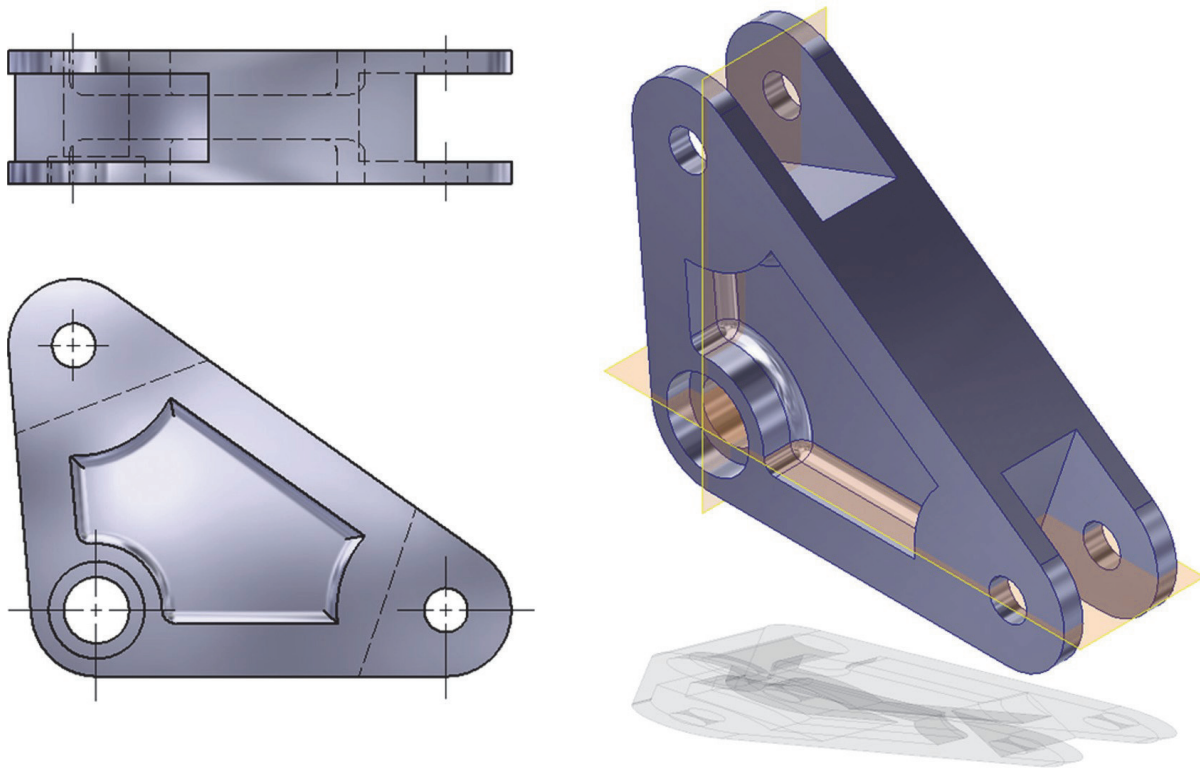

1.5 Model of a Machine Part Created with 3D Modeling Software

Civil drafters and *design technicians* prepare construction drawings and topographical maps used in civil engineering projects. Civil projects may include roads, bridges, and water and waste-water systems. Civil drafters may also work for surveying companies to create site plans and plats for new subdivisions. Figure 1.6 shows an image of a subdivision plat created with AutoCAD Civil 3D® CAD software.

Electrical drafters prepare diagrams used in the installation and repair of electrical equipment and the building wiring. Electrical drafters create documentation for systems ranging from low-voltage fire and security systems to high-voltage electrical distribution networks.

Electronics drafters create schematic diagrams, printed circuit board (PCB) artwork, integrated circuit layouts, and other graphics used in the design and maintenance of electronic (semiconductor) devices. Figure 1.7 shows a detail from an electronics schematic drawing. Figure 1.8 shows a detail of a PCB prepared from the schematic shown in Figure 1.7.

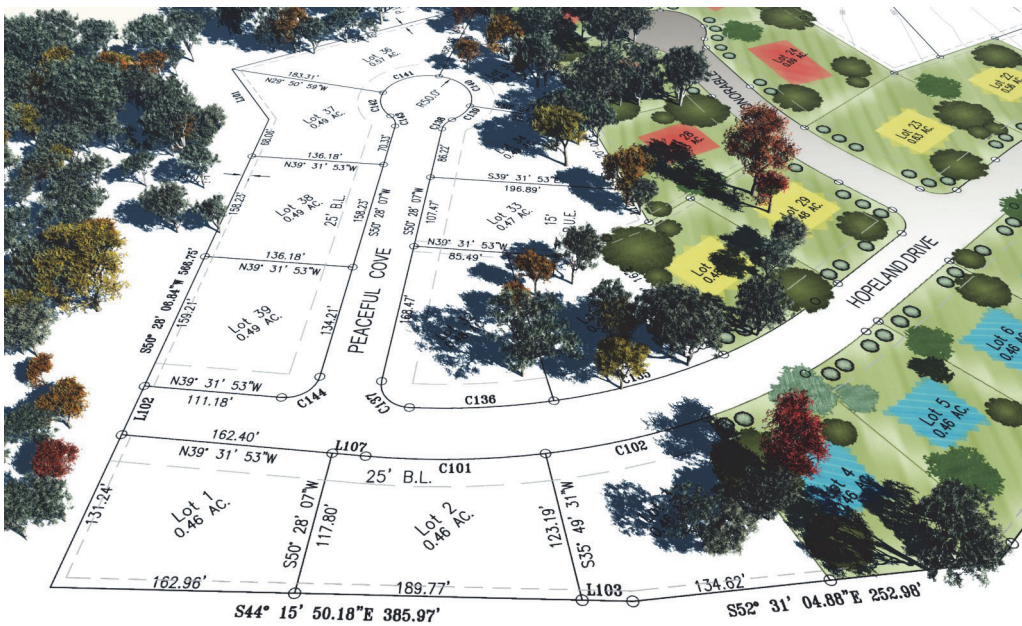

1.6 Civil Engineering Image Created for a Subdivision Plat.

Source: Image courtesy Jeffrey B. Muhammad.

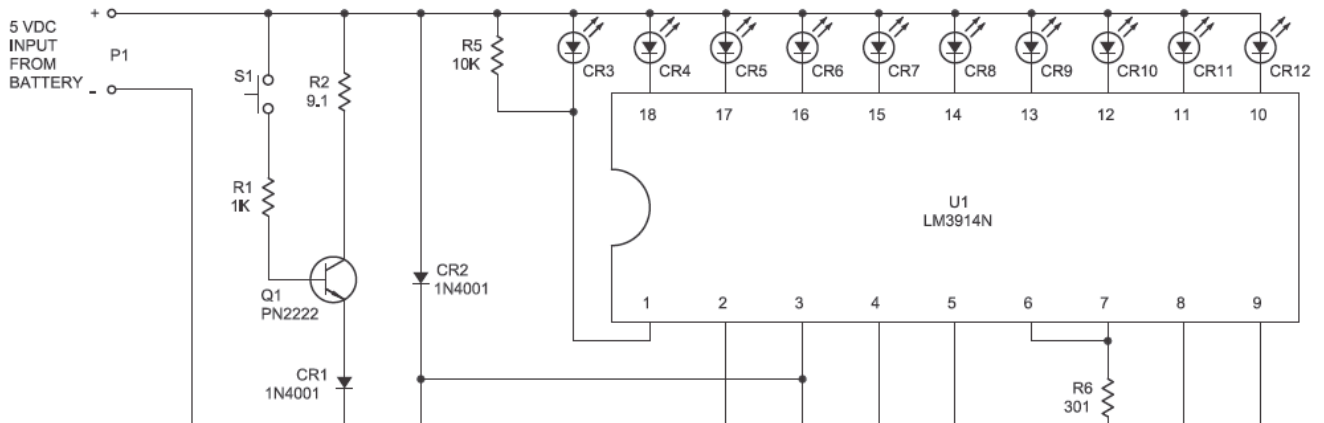

1.7 Detail from an Electronics Schematic

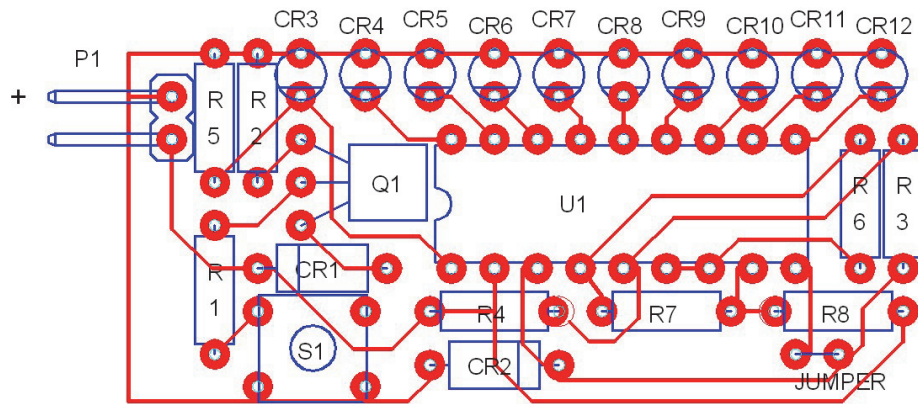

1.8 Detail of Printed Circuit Board Prepared from the Schematic Shown in Figure 1.7

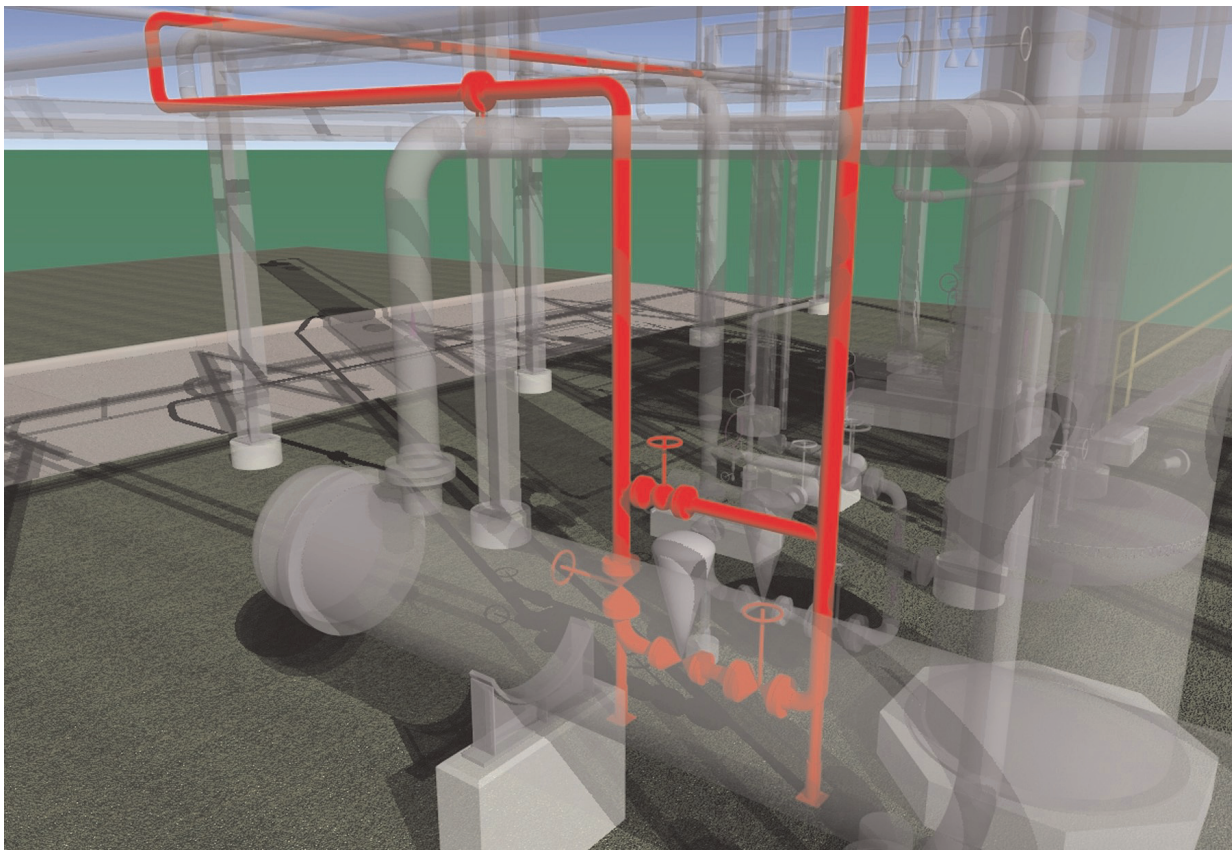

1.9 3D CAD Model of a Process Piping Design. Image Courtesy of Mustang Engineering L.P.

Pipeline drafters and *process piping drafters* prepare drawings used in the construction and maintenance of oil refineries, oil production and exploration industries, chemical plants, and process piping systems such as those used in the manufacture of semiconductor devices. Figure 1.9 shows a 3D CAD model of a process piping system created using CADWorx® Plant software.

Qualities That Employers Look for in Drafters

Most employers are very careful in making hiring decisions. Interviews are usually very thorough; in extreme cases, the interview process may take several hours. Candidates may be called back for more than one interview.

When interviewing for a job, the candidate may interview with one person or with the entire design team. In the modern engineering or architectural office, the candidate's attitude regarding work and his or her ability to learn quickly and contribute to the team immediately is factored into the hiring decision. Often, tests are administered during the interview to measure proficiency with CAD or the candidate's understanding of necessary concepts that should have been mastered while in college or during other training.

Typical Interview Questions

- Are you a quick learner (will you contribute to the organization quickly)?
- Are you intelligent, competent, and energetic?
- Will you fit into the team? Do you get along with others?
- Did you make good grades in your major? Will your instructors give you a good recommendation?
- Do you meet deadlines?
- Are you able to work successfully both in groups and individually?
- Did your training prepare you for this job?
- Do you communicate well with others (both verbally and in writing)?
- Do you have good work habits? Are you dependable?
- Will the employer profit from your work?

JOB SKILLS

If you are interested in working in the technical drawing field, develop good work habits while you are in school. Set high standards for your work, strive to create outstanding drawings for your portfolio, and be able to explain how the drawings in your portfolio were created and why. Come to class prepared and on time, meet your deadlines, and try to impress your instructors with your work habits and attitude, because often the recommendation of a current or former instructor will determine whether you get a job.

Salary Information for Drafters, Architects, and Engineers

Earnings for drafters vary depending on the specialty (architecture, mechanical, electrical/electronics, etc.), level of responsibility, and geographic area. According to U.S. Department of Labor statistics (2012), median annual earnings for architectural and civil drafters were \$47,870, median annual earnings for mechanical drafters were \$50,360, and median annual earnings for electrical and electronics drafters were \$55,700.

By comparison, median annual earnings for architects were \$73,090, median annual earnings for mechanical engineers were \$80,580, median annual earnings for civil engineers were \$79,340, and median annual earnings for electrical engineers were \$89,630.

NOTE

Median earnings refer to the middle of a distribution; that is, half the earnings are above the median, and half are below the median.

Salary data taken from the Bureau of Labor Statistics, U.S. Department of Labor, Occupational Outlook Handbook, 2014-15 Edition, Drafters, on the Internet at <http://www.bls.gov/ooh/architecture-and-engineering/drafters.htm>.

Job Prospects for Drafters

According to the U.S. Department of Labor, approximately 200,000 Americans were employed as drafters nationwide in 2012. Overall employment for drafters varies nationwide by discipline and geographic region. For example, mechanical drafters will find more employment opportunities near large manufacturing hubs while architectural and civil drafters may find more job openings in regions experiencing rapid growth in population.

TIP

You can find out more about careers in drafting by visiting the U.S. Department of Labor website at:
<http://www.bls.gov/ooh/architecture-and-engineering/drafters.htm#tab-6>

1.4 THREE TECHNICAL DRAWING SUCCESS STORIES

Jeffrey Muhammad first began taking drafting courses at Temple College in Temple, Texas, and later transferred to Austin Community College (ACC) in Austin, Texas. In 1996, before he completed the requirements for his associate’s degree at ACC, Jeffrey was hired by Wenzel Engineering in Austin. While at Wenzel, Jeffrey used AutoCAD to prepare site-plan development drawings and on-site wastewater management systems. Jeffrey continued to take classes at night and in 2003 received his Associate of Applied Science degree in Architectural and Engineering Computer Aided Design at ACC. Jeffrey’s next position was with Loomis Austin, a civil engineering firm, where he was involved in subdivision platting, street design, utility design, site-plan development, and land planning. While employed by Loomis, Jeffrey used AutoCAD® Land Desktop and AutoCAD® Civil 3D® software to perform his job functions. At present, Jeffrey is employed as a full-time instructor at a community college, where he is the coordinator of the Civil CAD program.

Elain Dalton already had a bachelor’s degree from the University of Oregon when she decided to take a drafting course at the University of Houston “just for fun.” Using the skills she developed in that class, Elain was able to find a job with John-son Controls’ “Star Wars” defense base in the Marshall Islands (a U.S. territory in the South Pacific) doing facilities operations and master planning.

The job required that Elain split her time between two CAD programs: AutoCAD® and Microstation. There was only one small snag—Elain would have to teach herself to use both programs, which she did. When Elain returned to the continental United States, she took a job with Carrier Corporation and enrolled in the drafting program at San Jacinto Community College in Pasadena, Texas, earning an Associate of Applied Science degree in 1996. Her work with Carrier Corporation involved mechanical, electrical, and pipe drafting for clients such as Dow Chemical, Vulcan Chemicals, DuPont, and other corporations using commercial heating and cooling systems. She was also responsible for ensuring that the drawings complied with **American Society of Mechanical Engineers** standards.

Elain is currently employed as a drafter/designer in Houston, Texas, where she uses AutoCAD to create mechanical, civil, site-mapping, and piping drawings.

Bryan Lym began his path to a career in architecture in an unusual way—he dropped out of high school. After working at a variety of jobs, he was encouraged by a friend to take the GED® test at El

Centro College, a community college in Dallas, Texas. Bryan passed his test and went on to enroll in the architectural drafting program at El Centro. In these drafting classes, Bryan discovered that both his aptitudes and interests lay in the field of architecture. Near the end of his second year at El Centro, he was accepted into the School of Architecture at the University of Texas. On his graduation day in 1997, Bryan received two degrees: a Bachelor of Architecture and a Bachelor of Science in Architectural Engineering. Following graduation, Bryan held positions with RNL Design, Beck Construction, and Carter and Burgess. While employed at Carter and Burgess, Bryan began taking the licensure exams of the American Institute of Architects, and in 2003 he became a licensed architect. That same year, he began his own firm, Lym Architecture. Today his practice focuses primarily on designs for commercial remodels. His office uses a variety of software including AutoCAD, 3D Studio Max®, Sketch Up, Adobe® Photoshop® and Illustrator®, Word®, Excel®, and Adobe Acrobat®.

Because he had dropped out of high school, Bryan believes that if he had not been offered the second chance at El Centro College, he would never have been accepted into the architecture program at the University of Texas.

KEY WORDS

Aeronautical or Aerospace Drafters

American Institute of Architects

American Society of Mechanical Engineers

Architectural Drafters

Civil Drafters

Computer-Aided Design (CAD) Designers

Design Technicians

Drafters

Drafting

Electrical Drafters Electro/mechanical Drafters Electronics Drafters Engineering Drawings

Engineering Graphics Mechanical Drafters

National Society of Professional Engineers

Pipeline Drafters Process Piping Drafters Professional Engineer Technical Drawings

CHAPTER SUMMARY

The curriculum of this course is designed to introduce students to the field of technical drawing. This course is a good way to explore whether you possess the interests and aptitudes to pursue a career in which technical drawings are created or interpreted. If you wish to pursue more training, most community colleges and many universities offer specialized courses in engineering or architectural drawing. Your instructor may also be able to advise you on training opportunities and possible career paths.

REVIEW QUESTIONS

Short Answer

1. Name three terms that are used to describe the creation of technical drawings.
2. In which field must a drafter be familiar with floor plans, elevations, and construction details?
3. How can an employer find out about a student's CAD skills, work habits, and dependability?
4. A drafter who divides his or her duties between mechanical drafting and electrical/electronics drafting is known as what kind of drafter?
5. Name the job titles of people who might constitute a design team.

Multiple Choice

1. The acronym AIA stands for what?
 - a. Architectural Institute of America
 - b. American and International Architects
 - c. American Institute of Architects
 - d. Association of International Architects
2. According to the U.S. Department of Labor Statistics (2008), which field of drafting has the highest median salary?
 - a. Architectural
 - b. Mechanical
 - c. Electronics
 - d. Radiological
3. In which field must a drafter be familiar with roads, bridges, water and wastewater systems, and surveying techniques?
 - a. Architectural
 - b. Civil
 - c. Electronics
 - d. Mechanical
4. Which of the following attributes do most employers value?
 - a. Ability to fit into a team
 - b. Ability to work independently
 - c. Ability to communicate clearly
 - d. All the above
5. Designers have a higher salary than drafters because:
 - a. They usually have advanced technical degrees.
 - b. They are licensed.
 - c. They work longer hours than drafters.
 - d. They have a higher degree of responsibility for the success of the project.

Matching

Column A

- a. Mechanical
- b. Process piping
- c. Bachelor's
- d. Electronics
- e. Associate's

Column B

1. Type of college degree held by most engineers and architects
2. Drafting field concerned with chemical plants and oil refineries
3. Type of college degree held by many drafters
4. Drafting field concerned with screw threads and fasteners
5. Drafting field concerned with design of semiconductor devices

CHAPTER EXERCISES

Exercise 1.1: Locate Bachelor Degree Programs in Architecture or Engineering

Conduct an internet search for university programs in your geographic area offering a bachelor's degree in architecture and/or engineering. Try to locate an online degree plan for each major, and compare the courses required for each degree.

Exercise 1.2: Locate Associate Degree Programs in CAD

Conduct an internet search for community college or technical school programs in your geographic area offering an associate's degree in CAD or a related field. Try to locate an online degree plan for the program. Compare the courses required for the associate degree with the courses required in the bachelor's degree program.