

Visualization & Engineering Design Graphics With Augmented Reality

Second Edition

Jorge Dorribo Camba
Jeffrey Otey
Manuel Contero
Mariano Alcañiz

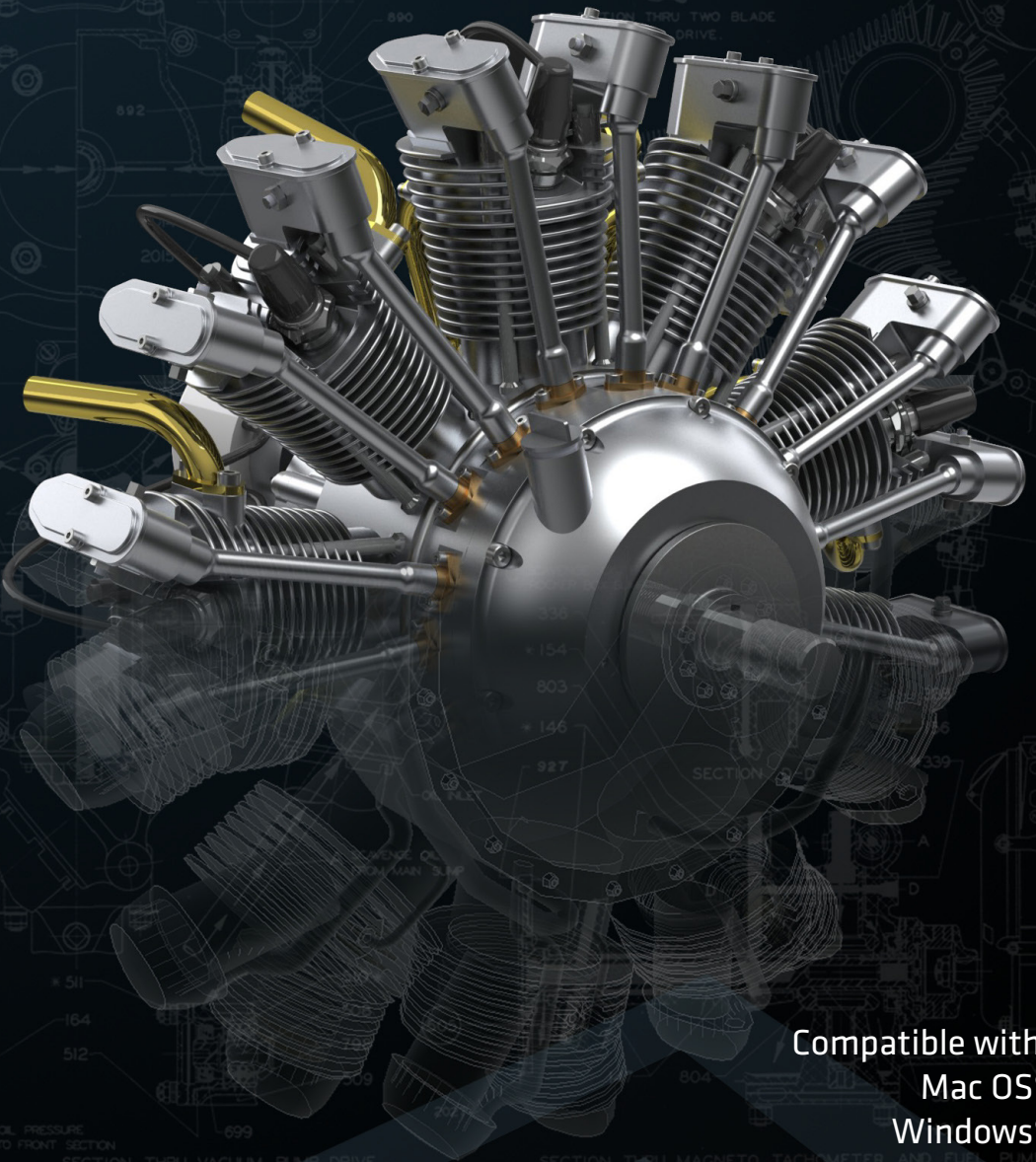

Compatible with:
Mac OS®
Windows®
iOS®
Android®

Visit the following websites to learn more about this book:



[amazon.com](https://www.amazon.com)

[Google books](https://books.google.com)

[BARNES & NOBLE](https://www.barnesandnoble.com)

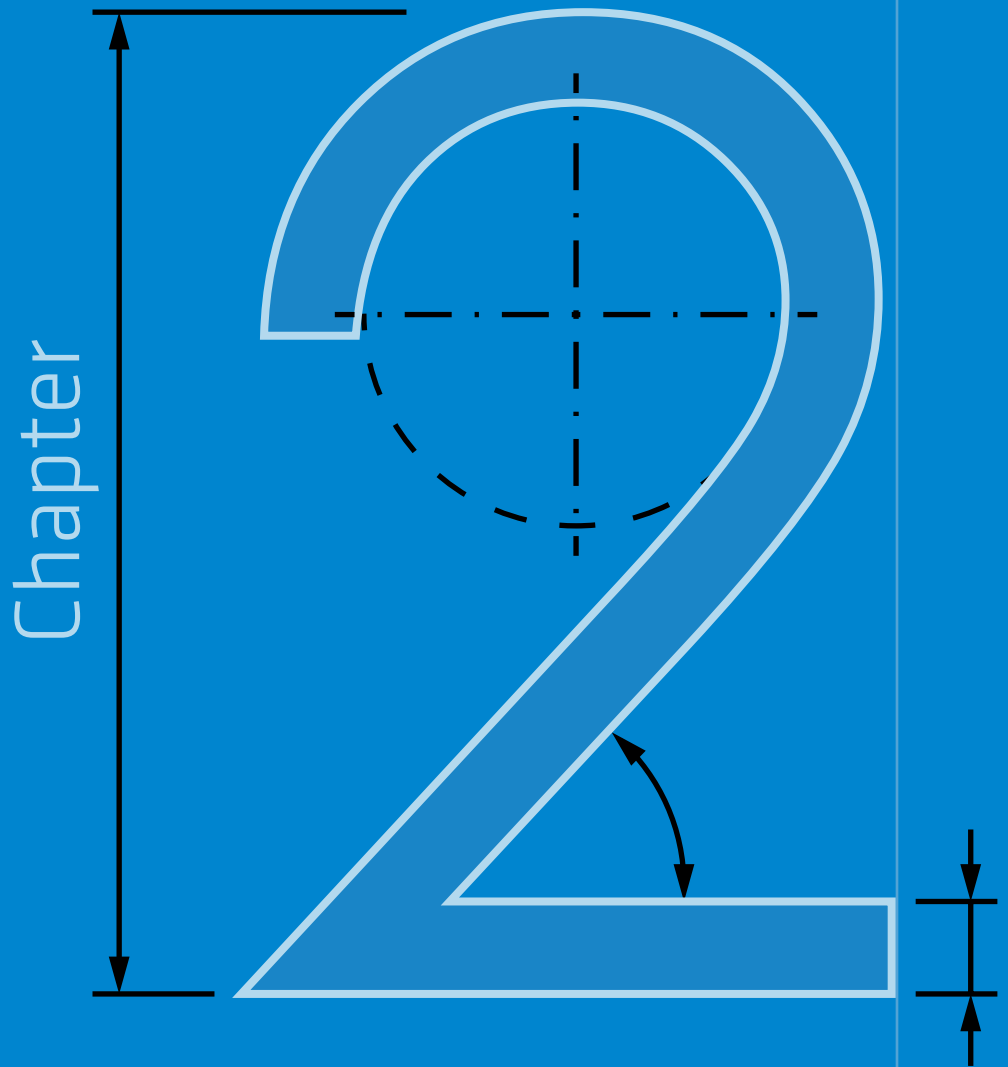

Orthographic Projection



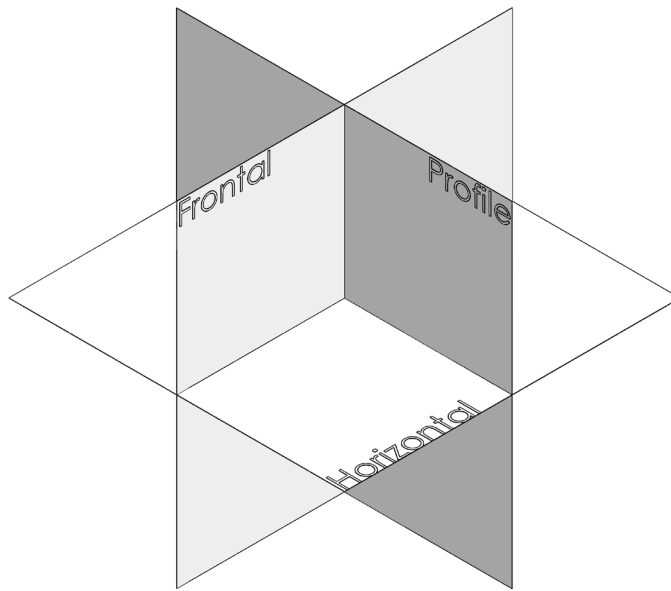
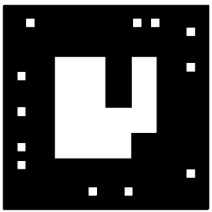
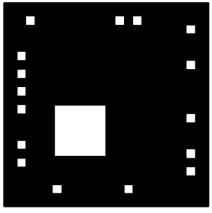
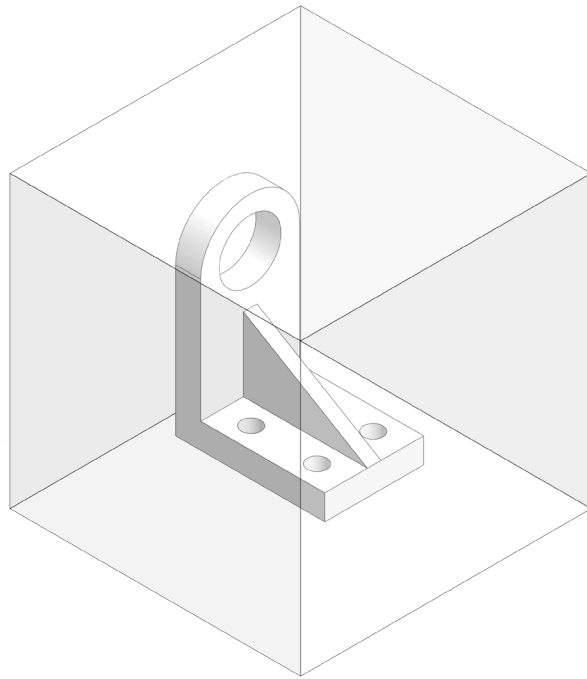

FIG. 2.1 Principal projection planes

Introduction

A common dilemma in engineering graphics presents itself when attempting to portray three-dimensional objects in two-dimensional space (a piece of paper). Unlike artistic drawings, which are primarily concerned with creating visually appealing representations of an object, technical drawings require methods to precisely specify its geometry, size, and structure to ensure that an object is manufactured exactly as the designer intended it. The most fundamental technique involved is called graphical projection.

Graphical projection is a system by which a three dimensional object is represented on a planar surface. There are different graphical projection methods that are used in technical graphics: orthographics, obliques, axonometrics, and perspectives. While obliques, perspectives, and axonometrics attempt to represent multiple faces of an object in a single drawing, orthographic projection uses a series of two-dimensional views, arranged in a standard manner, in order to fully document the object's geometry. This chapter introduces the primary method used in engineering: orthographic projection. The remaining techniques will be discussed in detail in subsequent chapters.



Bracket inside glass box **FIG. 2.2**

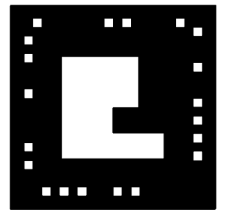
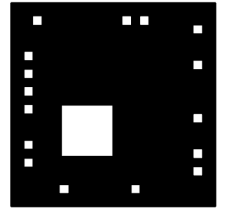

Orthographic Projection

Orthographic projection is a graphic representation method based on the creation of a group of two-dimensional views using three mutually perpendicular planes called frontal, horizontal, and profile. These planes intersect each other at 90° angles (see [Figure 2.1](#)).

To understand how orthographic projection works, visualize an object displayed inside an imaginary cube or glass box, like the bracket shown in [Figure 2.2](#).

The edges of the bracket are projected normally onto the planes of this imaginary glass box. You can think of this concept as an observer located outside the box looking at the object inside (see [Figure 2.3](#)). The process is then repeated for the six faces of the glass box, as shown in [Figure 2.4](#).

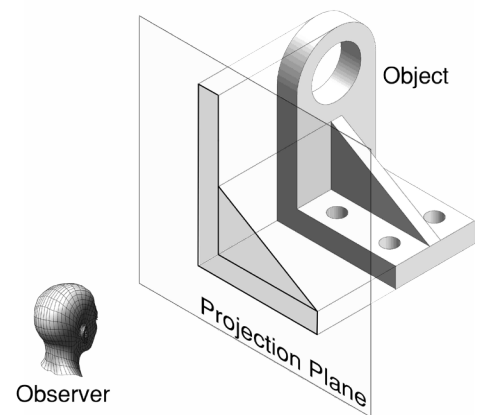

Projection on the glass plane **FIG. 2.3**

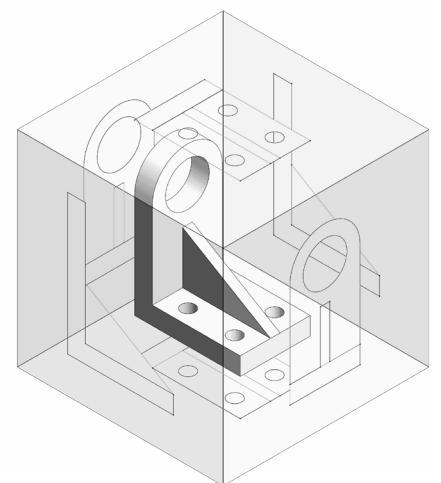

Views projected onto the faces of the box **FIG. 2.4**

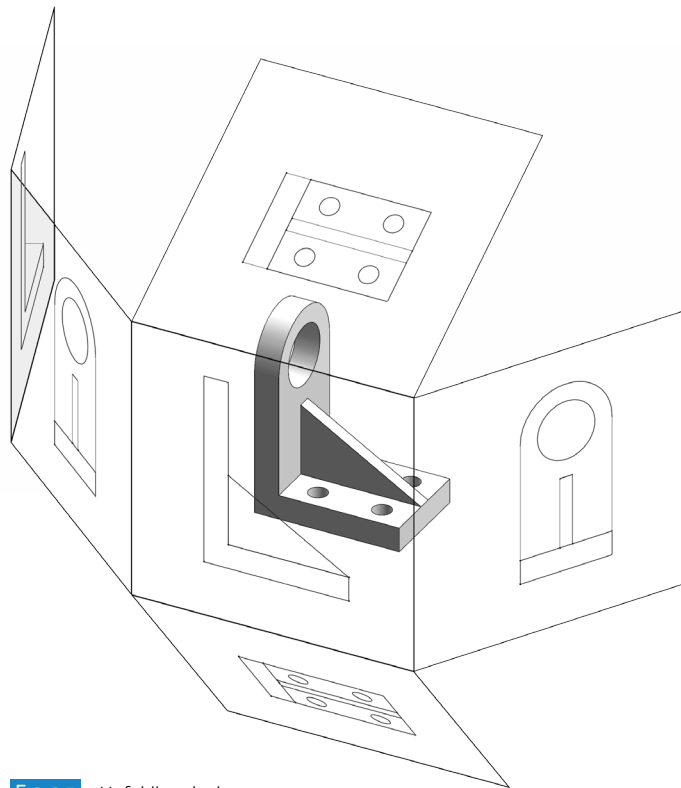
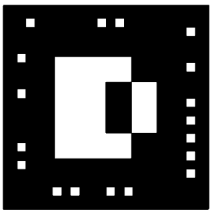
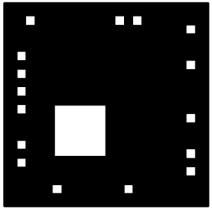

FIG. 2.5 Unfolding the box

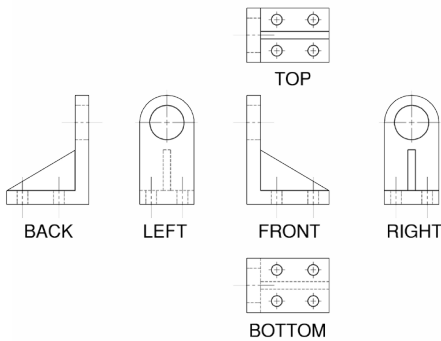

FIG. 2.6 Complete orthographic representation of the bracket

The six faces of the box are then unfolded in a standard manner so that the top view is shown directly above the front and the side view is placed directly to the side of the front view (see Figure 2.5). The six views generated are called the principal views and they constitute the complete orthographic representation of the object (see Figure 2.6).

Each orthographic view shows only two dimensions of the object, which means that more than one view is necessary to fully describe the object. For this reason, orthographic drawings are also called multiview drawings.

Orthographic views must be aligned and sufficiently spaced to allow for dimensions. Each view shares at least one dimension (width, height, and depth) with another view (see Figure 2.7). The front and back views correspond to the frontal plane, the top and bottom views correspond to the horizontal plane, and the left and right side views correspond to the profile plane. While the views associated with each plane are similar in appearance, they are mirror images of each other.

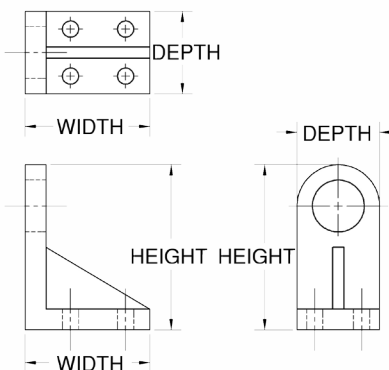
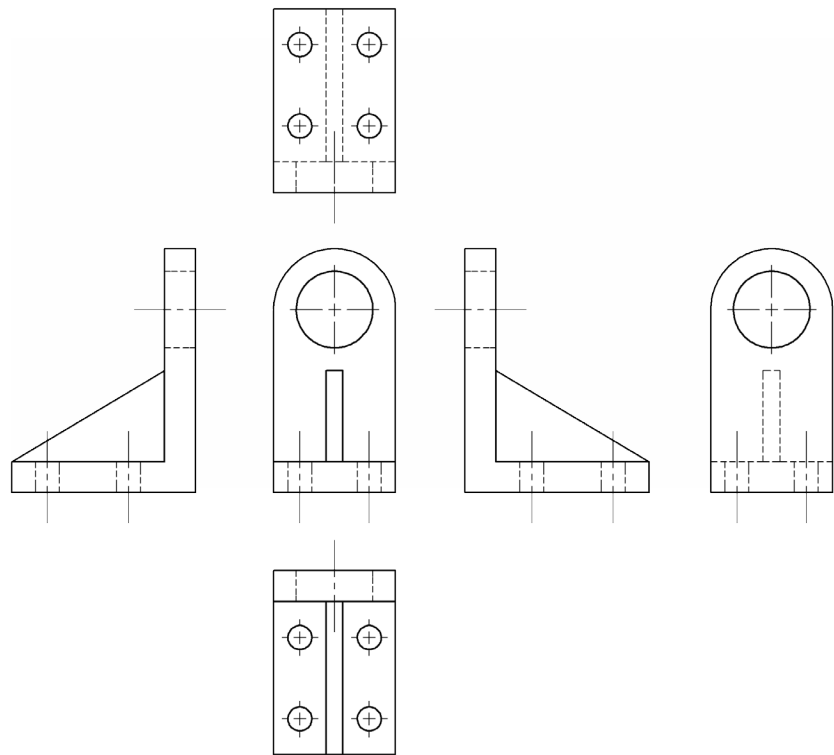

FIG. 2.7 Shared dimensions



Complete orthographic representation of the bracket in First Angle Projection **FIG. 2.10**

Projection Methods

There are two major methods in which an object's views are projected onto the enclosing glass box. In the United States, Third Angle Projection is used, which can be understood as viewing the object from outside the glass box. The examples shown in previous figures use Third Angle Projection. In other countries, however, the preferred method is First Angle Projection, in which the viewer is looking at the object from inside the box and the images are projected onto the planes behind the object. (see [Figure 2.8](#) and [Figure 2.9](#)).

The complete orthographic representation of the bracket in First Angle Projection is shown in [Figure 2.10](#).

Both First and Third Angle Projection methods are valid as they result in the same six views. The difference is the arrangement of these views around the glass box. To avoid confusion, the type of projection must be clearly indicated with a symbol on the drawing. The projection symbol for both projection methods consists on a truncated cone (see [Figure 2.11](#)).

Third Angle Projection is the default projection system used in the United States according to the standard ASME Y14.3-2003, which regulates multiview drawings. For this reason, all the examples and exercises in this book will use Third Angle Projection.

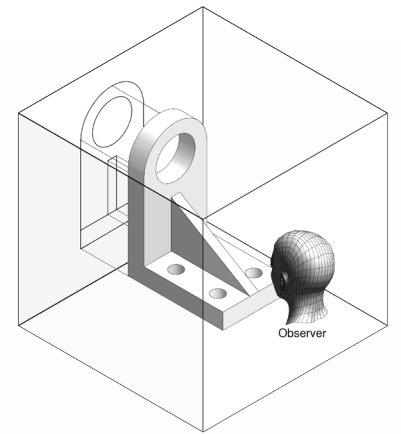

Observer located inside the box **FIG. 2.8**

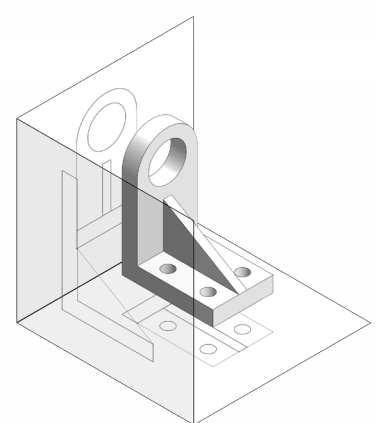

First Angle Projection **FIG. 2.9**



Left: 1st Angle Projection symbol **FIG. 2.11**
Right: 3rd Angle Projection symbol

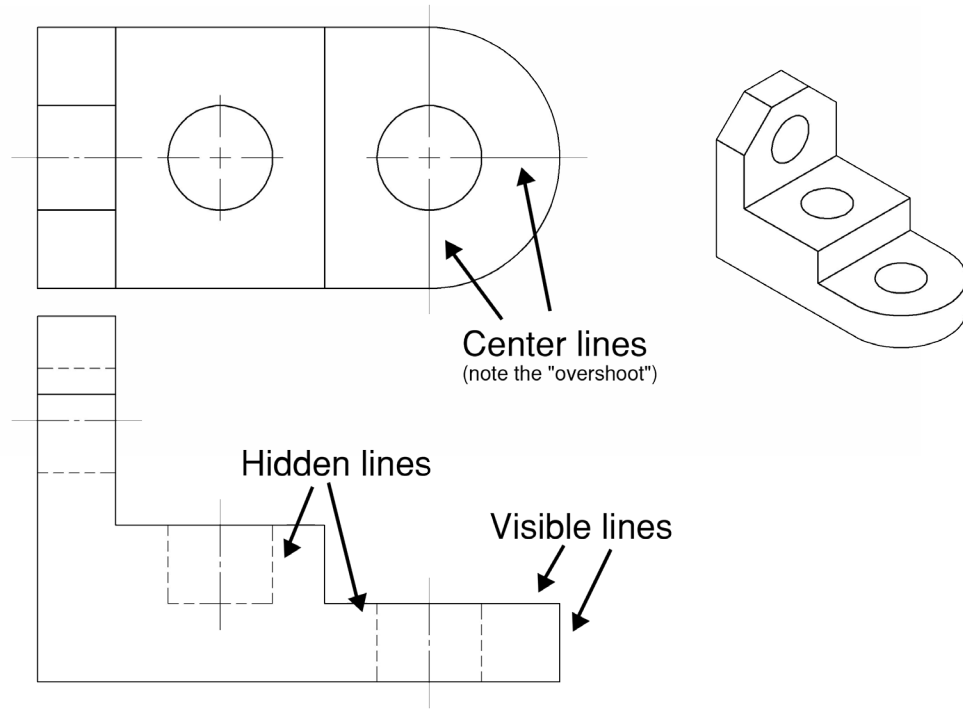
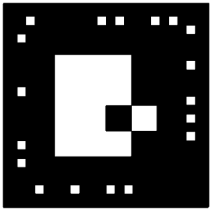
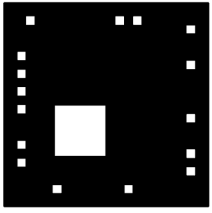

FIG. 2.13 Alphabet of lines

Alphabet of Lines

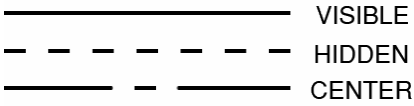

FIG. 2.12 Standard line types

In orthographic projection, different line types are utilized to show various geometric features. While standard line types have different patterns and thicknesses, they are all equally dark. Visible lines are thick, continuous lines used to portray edges and visible features. Hidden lines are thin, dashed lines used to illustrate features that are hidden behind visible surfaces. Center lines are thin lines, with alternating long and short dashes, used to indicate the centers of holes, cylinders, and arcs. The different line types are illustrated in Figure 2.12.

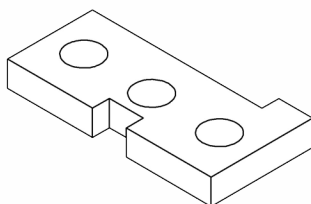
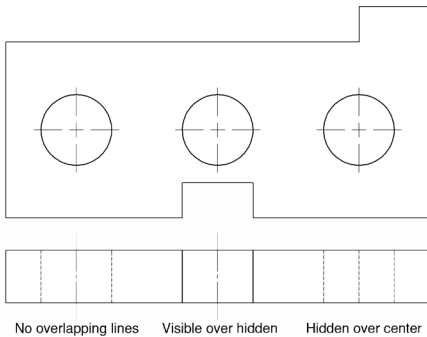
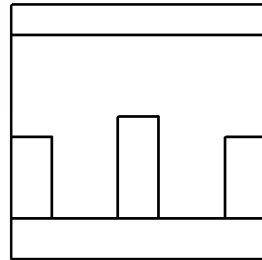
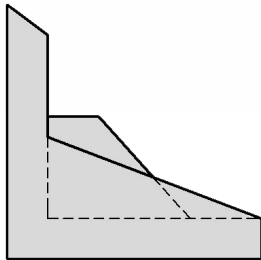
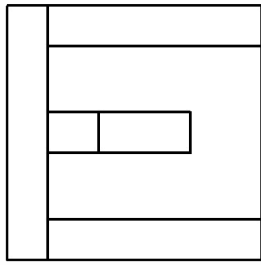

FIG. 2.14 Precedence of lines

Center lines are drawn equidistant from the edge of each edge in the rectangular view of a hole or cylinder and cross each other in the circular view. Center lines also extend a short distance past the visible edge see Figure 2.13). Construction lines are light lines, noticeable if the paper is held at arm's length, used as guidelines to make construction of other features easier. Construction lines are represented by a series of dots, but they are typically erased after the drawing is finished.

When lines happen to overlap, because various geometric features coincide, only one line is shown over the others. The rule is that visible lines take precedence over hidden lines and hidden lines take precedence over center lines. The precedence of lines is illustrated in Figure 2.14.



Most Descriptive View

Choosing the most descriptive view as front view **FIG. 2.15A**

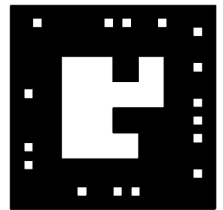
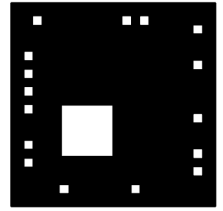

View Selection

Although there are six principal orthographic views generated by unfolding the imaginary glass box discussed previously, not all views are necessary to fully describe an object. Three of the views provide essentially the same information as the other three, except that they are viewed from the opposite direction.

In general, the number of orthographic views in a drawing must be kept to a minimum. For very simple objects with uniform thickness, a single view supplemented by a note is sufficient. Other objects may need two views, while more complex objects may need three or more. Conventionally for most objects, front, top, and right side views are used. Additionally, decisions must be made about which views should be selected as front, top, and side views. The following list provides guidelines to help make these determinations.

1. The most descriptive view should be selected as the front view. This view will usually have more curved or sloping lines, and reflect most of an object's distinguishing features. See [Figure 2.15](#).

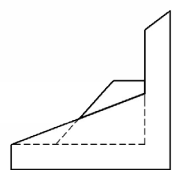
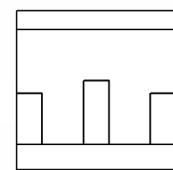
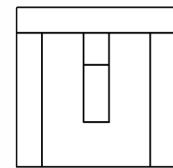

Not Most Descriptive View **FIG. 2.15B**

50

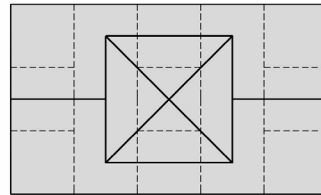
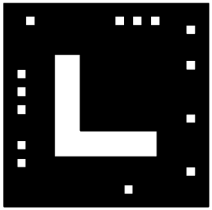
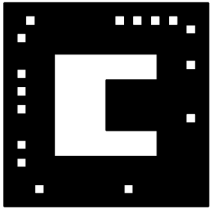

Obvious
Top View

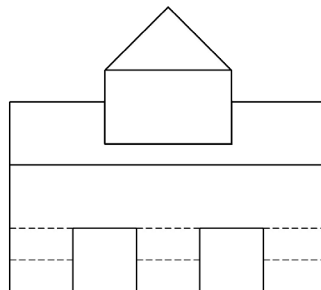
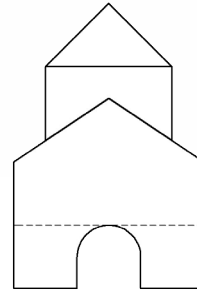
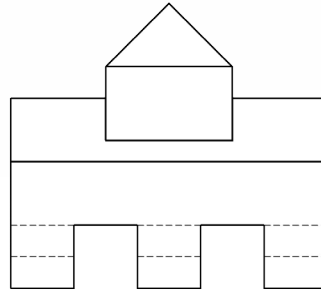

Not Obvious
Top View

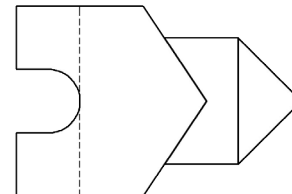
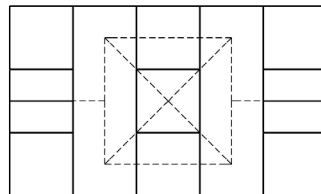
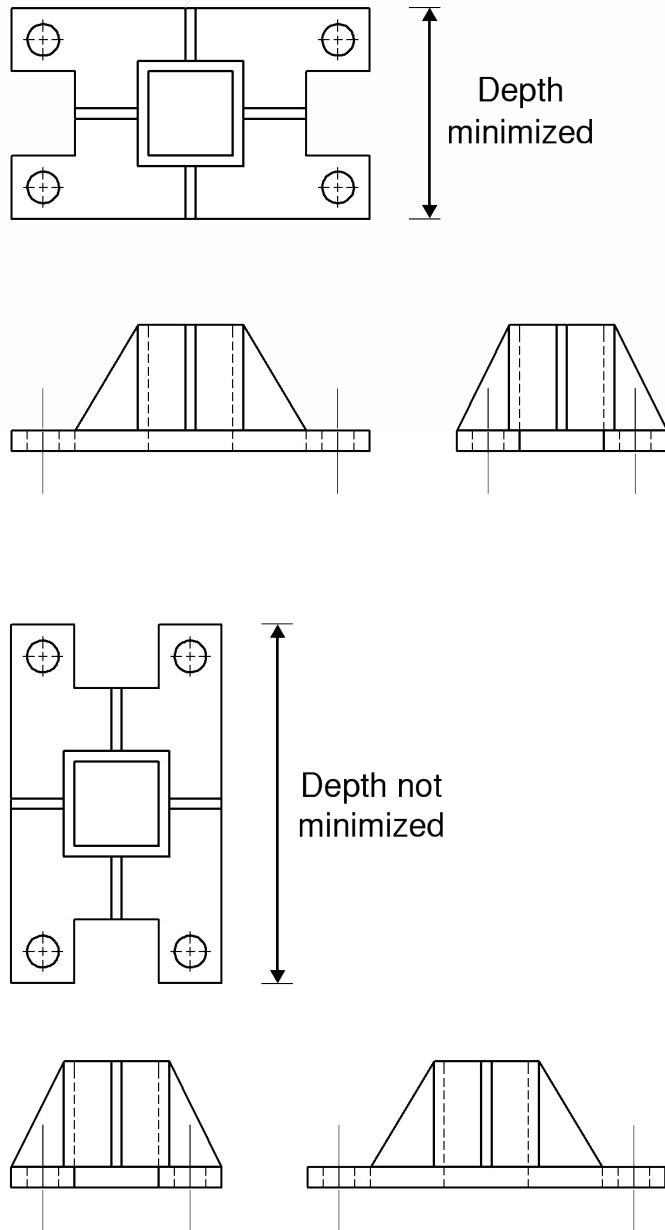
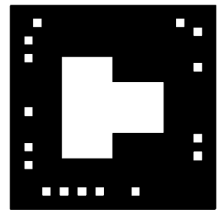
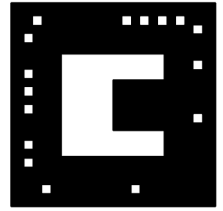

FIG. 2.16 Choosing the obvious top view

2. If an object has an obvious top, then that view should be selected as the top view. See [Figure 2.16](#).



Ensure that depth is minimized **FIG. 2.17**



- The depth dimension should be minimized in order to conserve space and provide adequate room for orthographic views of other objects on the same page. See [Figure 2.17](#).

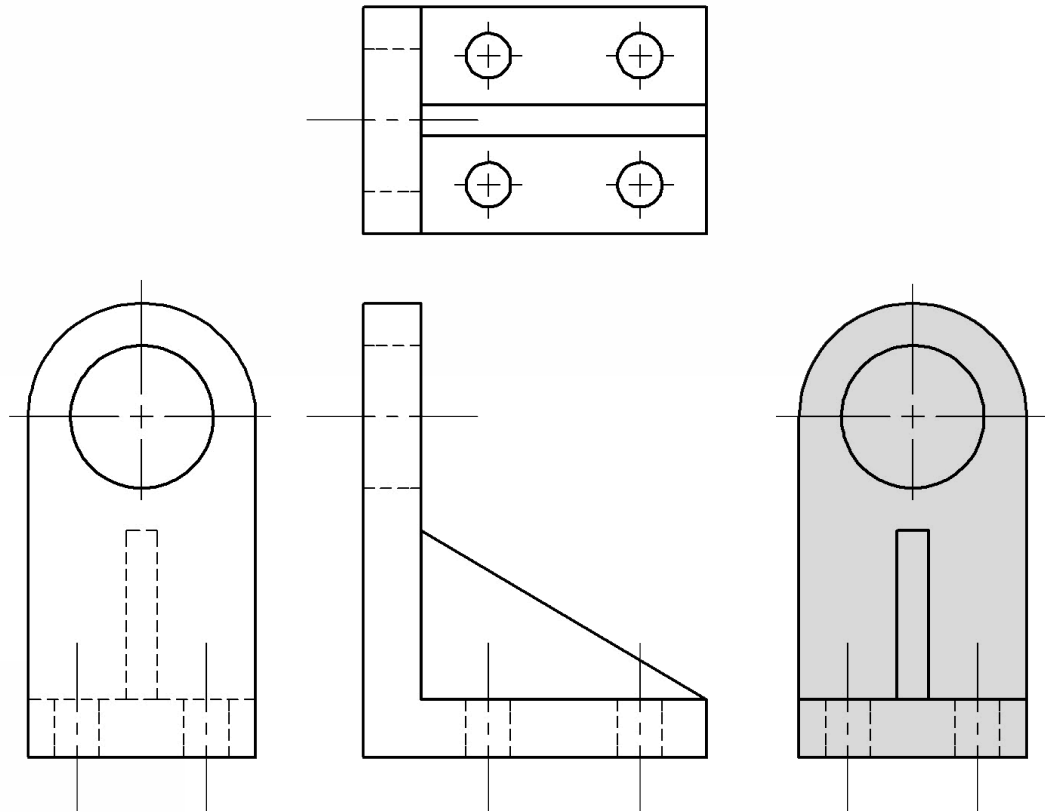
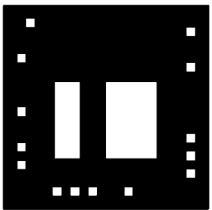
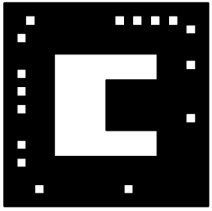
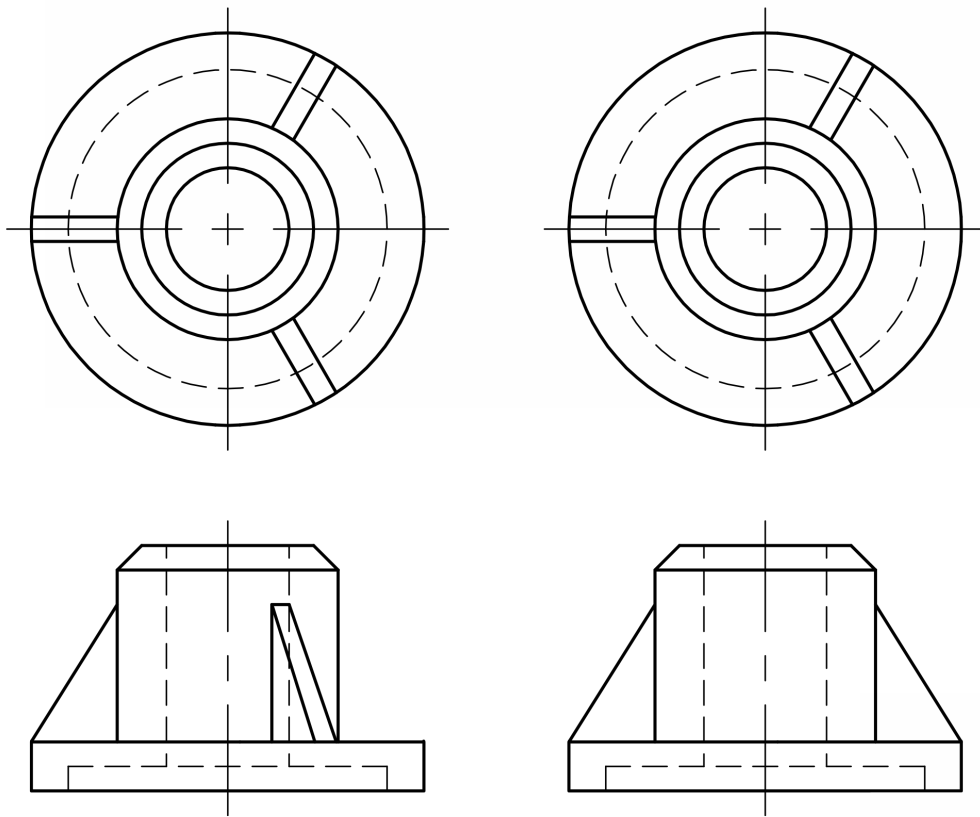

FIG. 2.18 Minimize the number of hidden lines

4. Views should be selected so that the total number of hidden lines in the drawing is minimized. See [Figure 2.18](#).
5. Both the left and right side views are acceptable in a drawing. However, if both views describe the object's geometry equally well, the right side view is conventionally preferred.

While the previous guidelines are recommended, there are situations where no clear cut case presents itself, such as when the obvious top view also maximizes depth. In such cases, experience and good judgment should be your guide.



Conventional rotations **FIG. 2.19**

Conventional Practices

Occasionally, it may be necessary to break standard orthographic projection rules in order to illustrate an object more clearly. A common example is when a cylindrical object has equally spaced features. In this case, the general orthographic views are correct, but confusing. In order to provide a more aesthetically pleasing view, while also increasing clarity, it may be useful to show the features spaced at 180° , even if the spacing is actually 60° . See [Figure 2.19](#).

Runouts are displayed when cylindrical features intersect rectangular features. A visible line is drawn to represent where this intersection occurs. See [Figure 2.20](#).

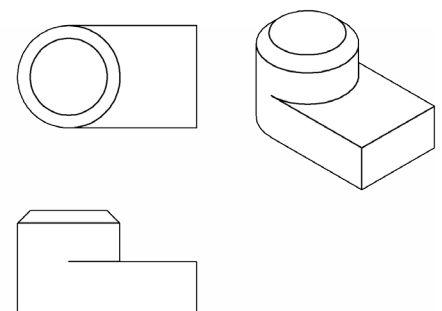

Proper representation of runouts **FIG. 2.20**

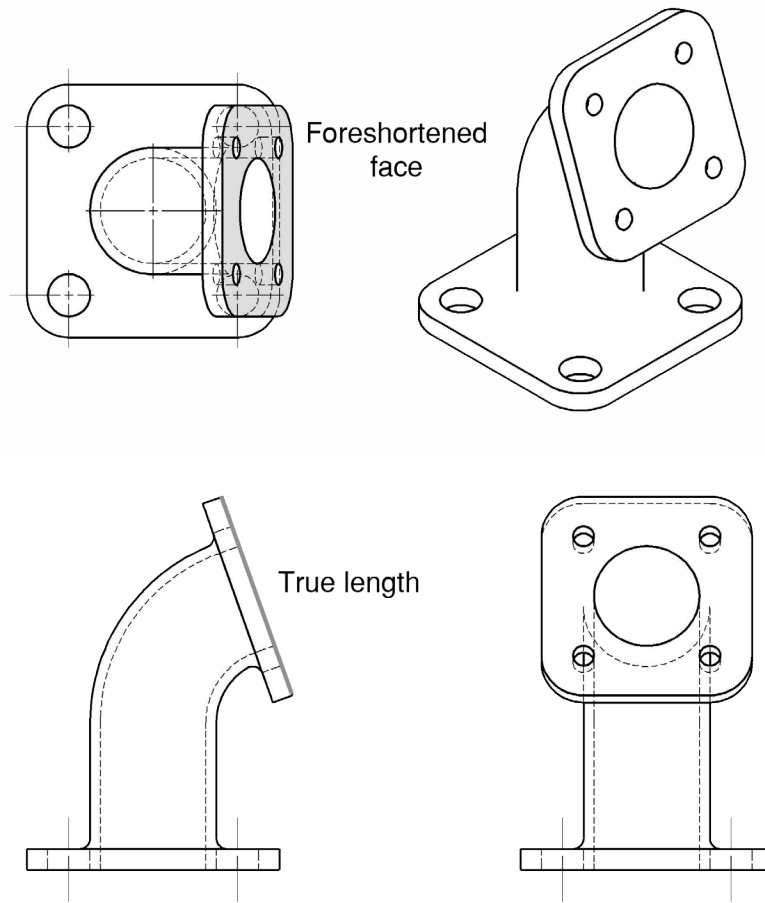
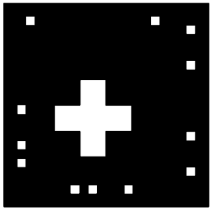
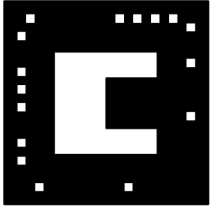
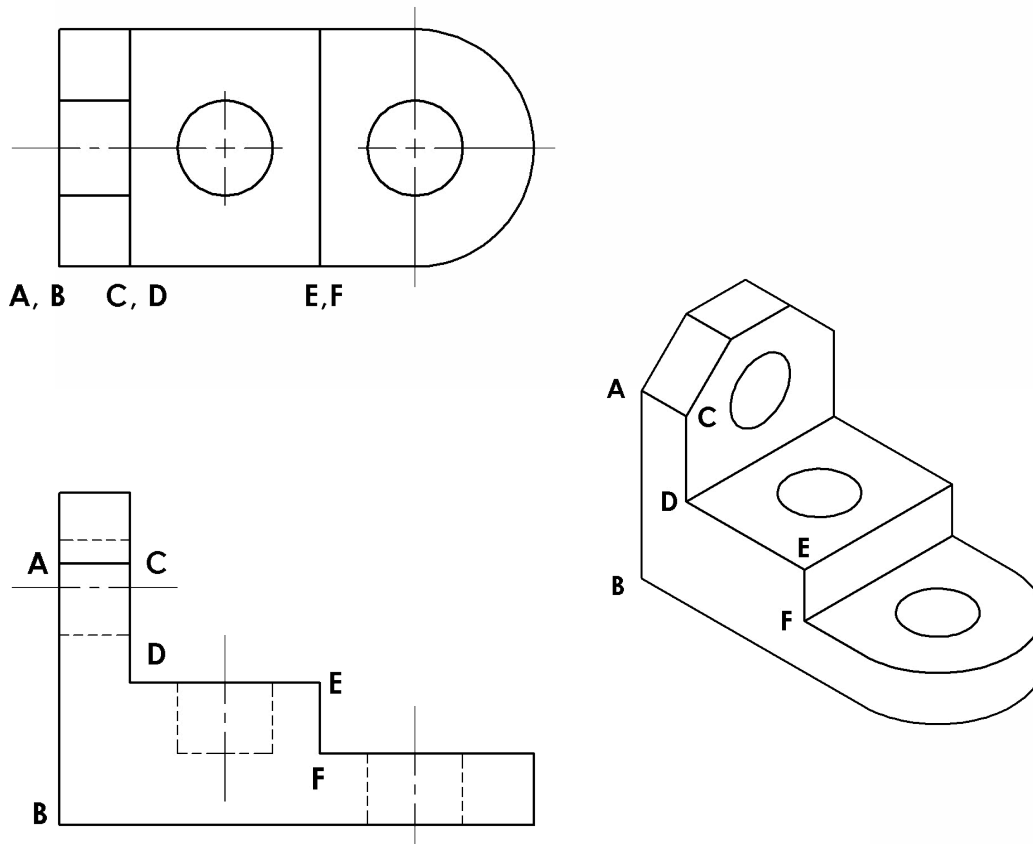

FIG. 2.21 Foreshortened distance

Foreshortening

Foreshortening occurs when a feature appears to be shorter than its true length because it extends away from the viewer. This concept appears oftentimes in orthographic projection since each view only portrays two dimensions. This situation can be alleviated with the use of auxiliary views, as you will study in future chapters. See [Figure 2.21](#).

Scheme for labeling edges and points **FIG. 2.22**

Orthographic Projection Aids

When working with orthographic projection, it may be helpful to label features on an object, such as lines, faces, and points. Depending on which orthographic view is considered, each feature could be shown as an edge or a face. Notice that no one orthographic view contains all the geometric information about an object. An important fact to consider is that a corner in one view is frequently shown as an edge in another. See [Figure 2.22](#) for an example of this process.

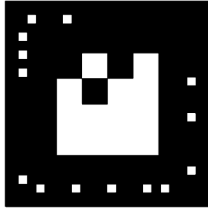
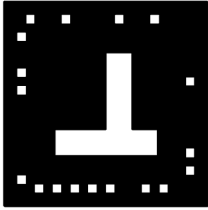

ORTHOGRAPHIC
PROJECTION

CHAPTER 02
EXERCISE 01

NAME:

DATE:

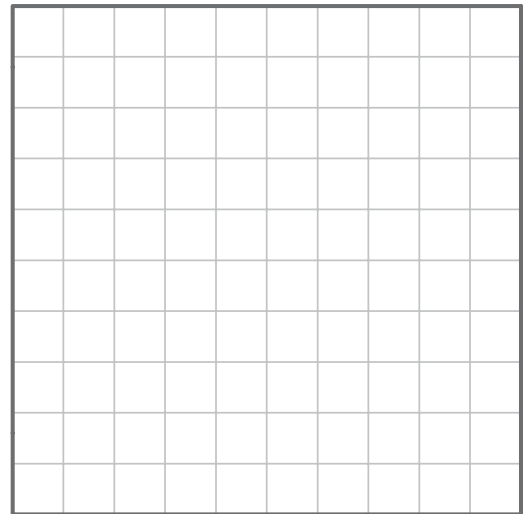
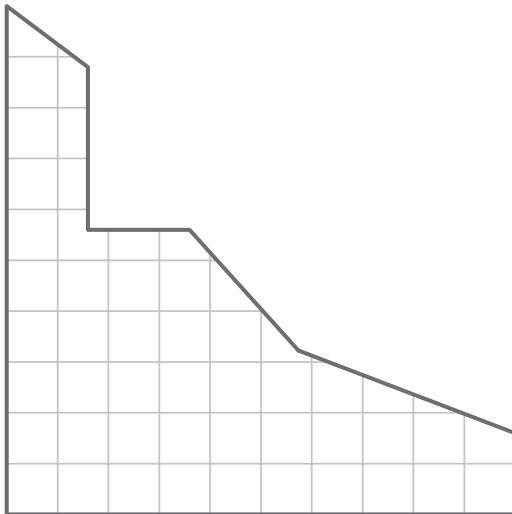
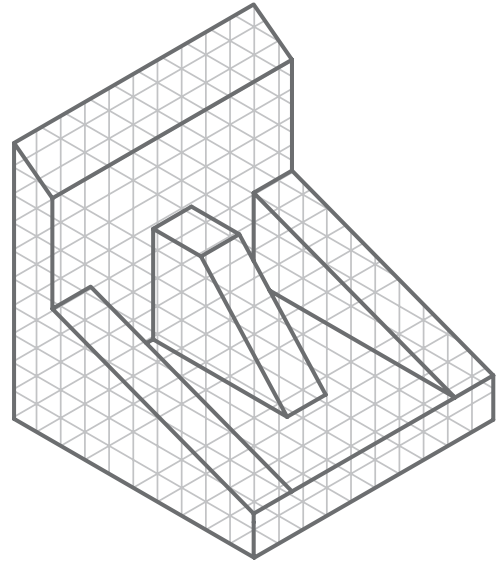
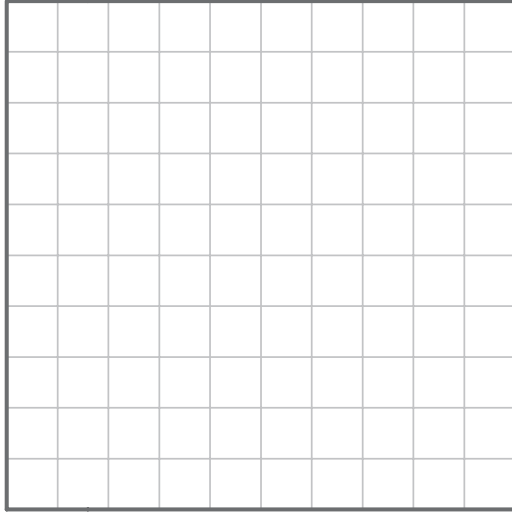

ADD THE MISSING LINES TO THE ORTHOGRAPHIC VIEWS PROVIDED. ALL LINES MUST FIT INSIDE THE EXISTING BOUNDARIES. ROUND UP TO THE NEAREST GRID SQUARE.

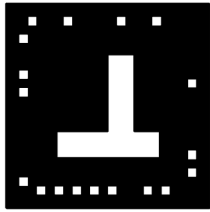

ORTHOGRAPHIC
PROJECTION

CHAPTER 02
EXERCISE 02

NAME:

DATE:

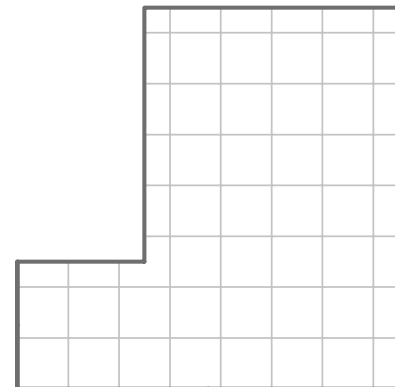
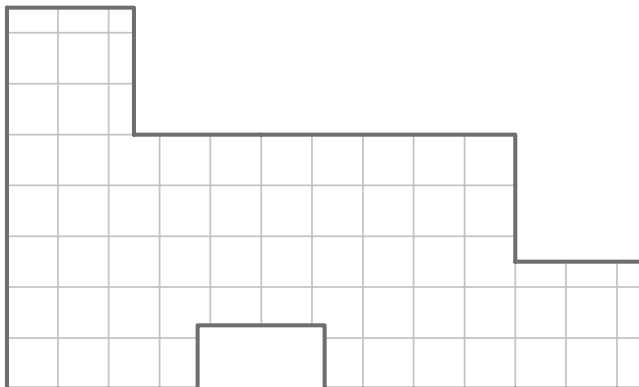
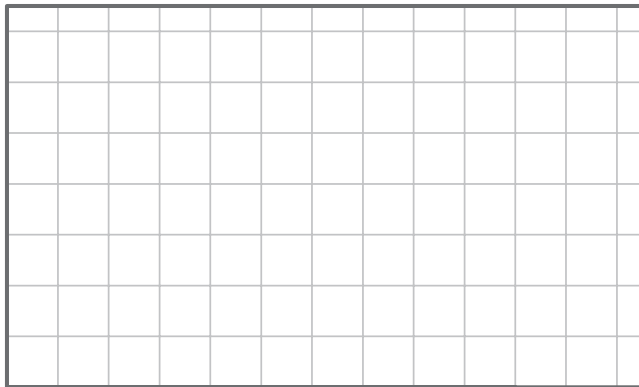
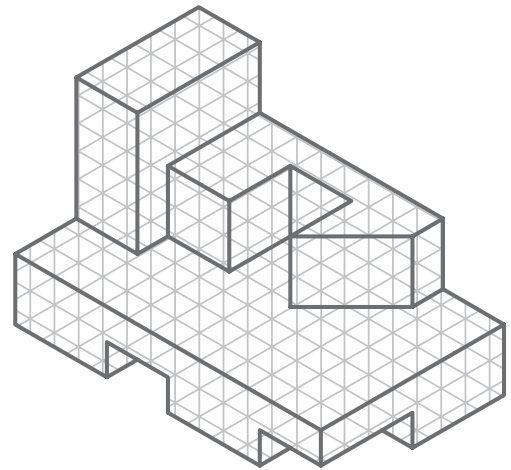

ADD THE MISSING LINES TO THE ORTHOGRAPHIC VIEWS PROVIDED. ALL LINES MUST FIT INSIDE THE EXISTING BOUNDARIES. ROUND UP TO THE NEAREST GRID SQUARE.

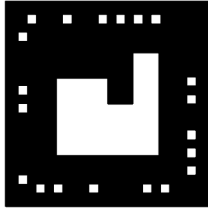
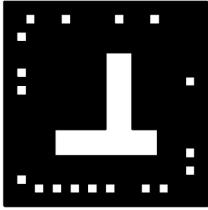

ORTHOGRAPHIC
PROJECTION

CHAPTER 02
EXERCISE 03

NAME:

DATE:

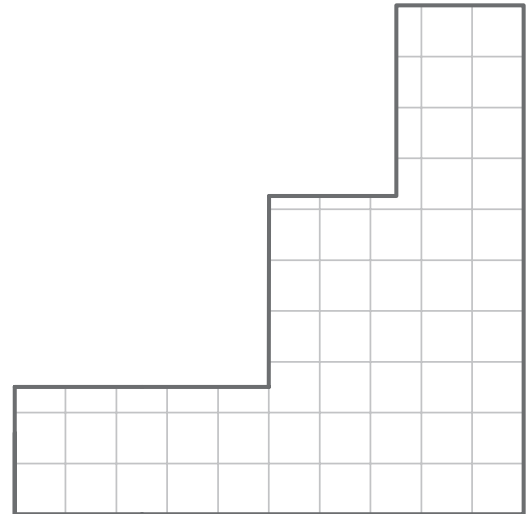
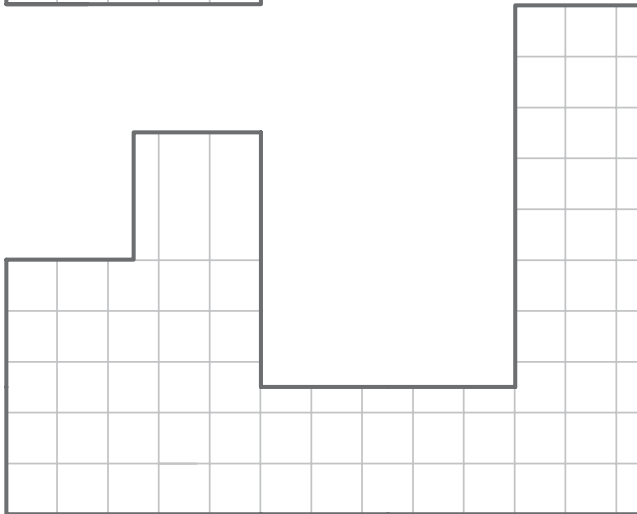
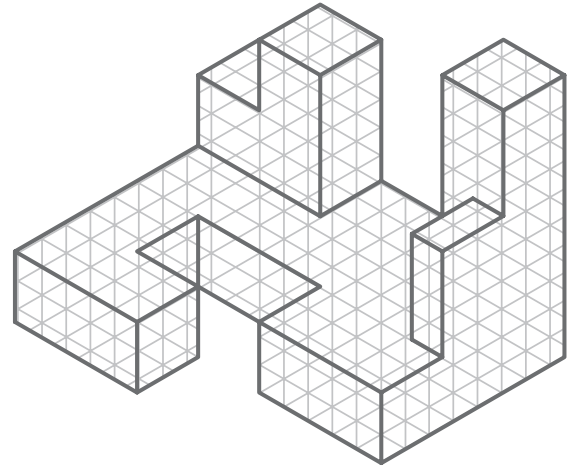
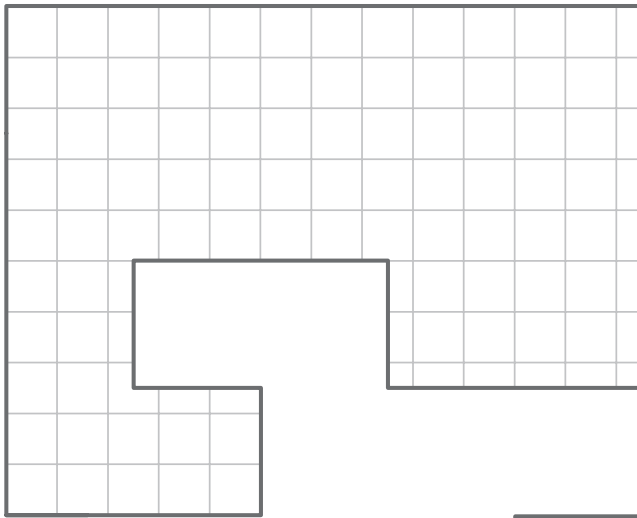

ADD THE MISSING LINES TO THE ORTHOGRAPHIC VIEWS PROVIDED. ALL LINES MUST FIT INSIDE THE EXISTING BOUNDARIES. ROUND UP TO THE NEAREST GRID SQUARE.

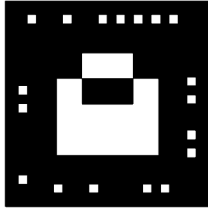
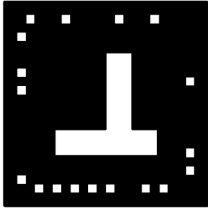

ORTHOGRAPHIC
PROJECTION

CHAPTER 02
EXERCISE 04

NAME:

DATE:

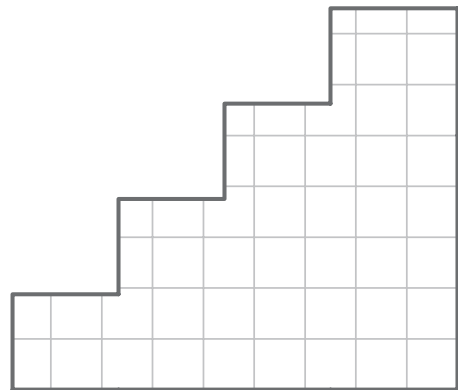
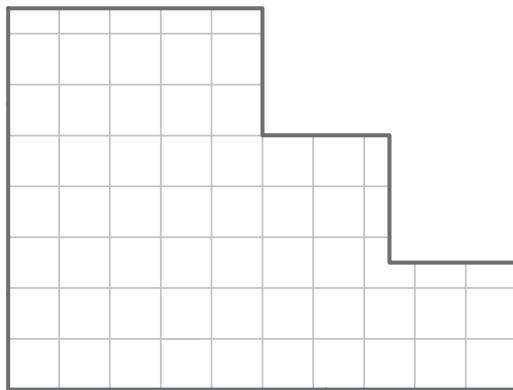
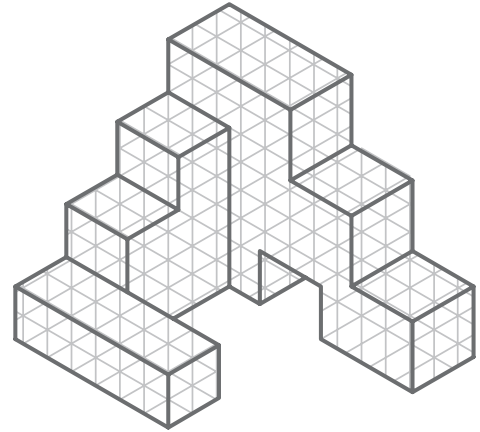
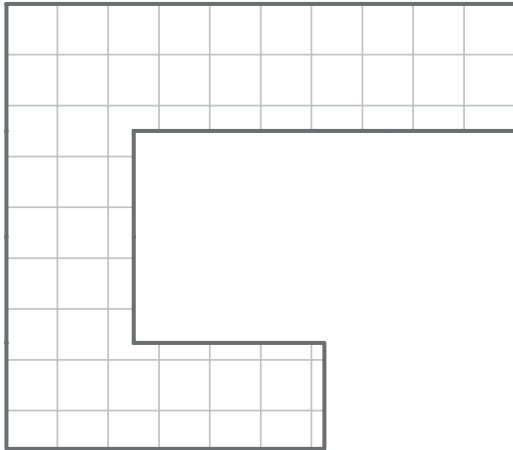

ADD THE MISSING LINES TO THE ORTHOGRAPHIC VIEWS PROVIDED. ALL LINES MUST FIT INSIDE THE EXISTING BOUNDARIES. ROUND UP TO THE NEAREST GRID SQUARE.

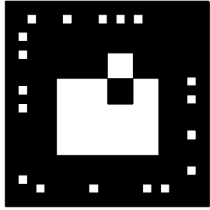
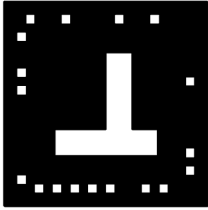

ORTHOGRAPHIC
PROJECTION

CHAPTER 02
EXERCISE 05

NAME:

DATE:

The 3D drawing shows a central rectangular block with a semi-circular cutout on its top surface. This central block is flanked by two smaller rectangular blocks. The entire object is drawn on a grid background.

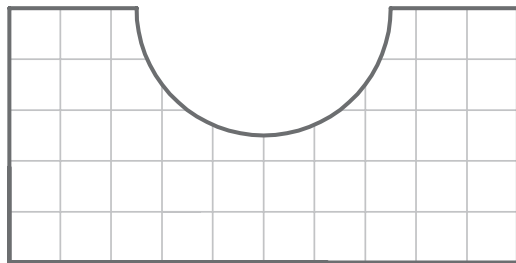
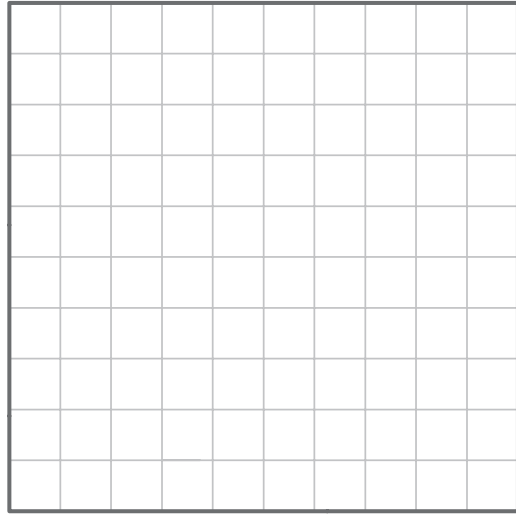

ADD THE MISSING LINES TO THE ORTHOGRAPHIC VIEWS PROVIDED. ALL LINES MUST FIT INSIDE THE EXISTING BOUNDARIES. ROUND UP TO THE NEAREST GRID SQUARE.

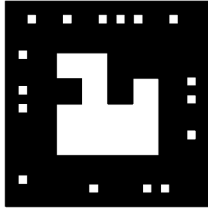
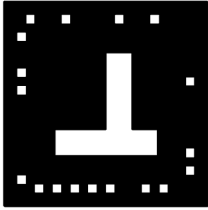

ORTHOGRAPHIC
PROJECTION

CHAPTER 02
EXERCISE 06

NAME:

DATE:

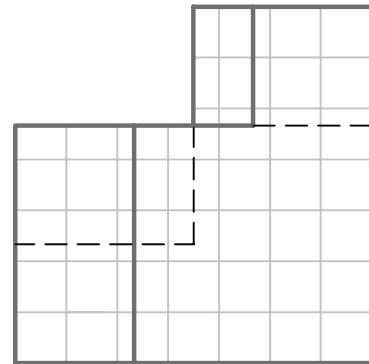
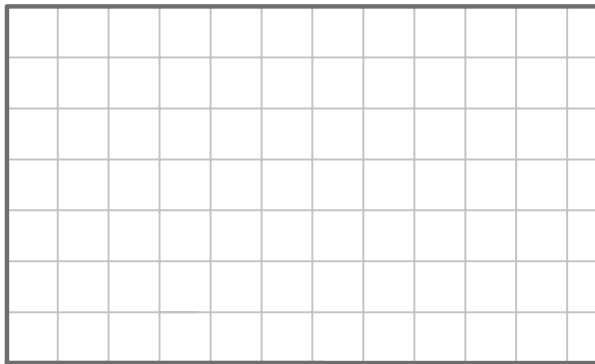
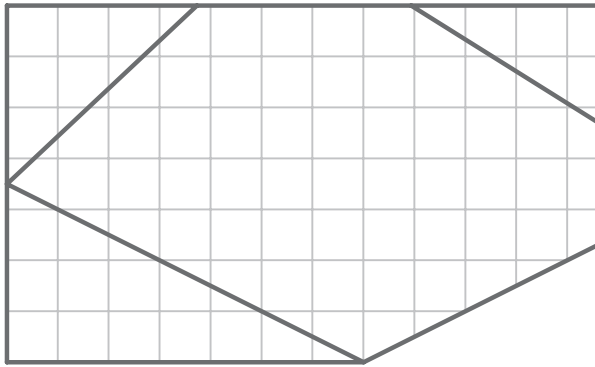

SKETCH THE MISSING VIEW. ALL LINES MUST FIT INSIDE THE EXISTING BOUNDARIES.
ROUND UP TO THE NEAREST GRID SQUARE.

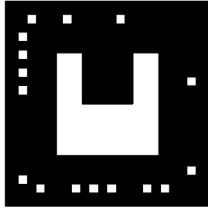
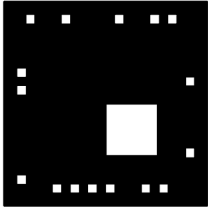

ORTHOGRAPHIC
PROJECTION

CHAPTER 02
EXERCISE 07

NAME:

DATE:

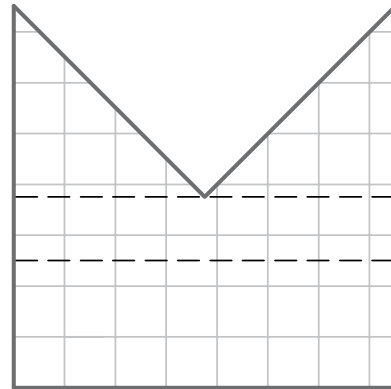
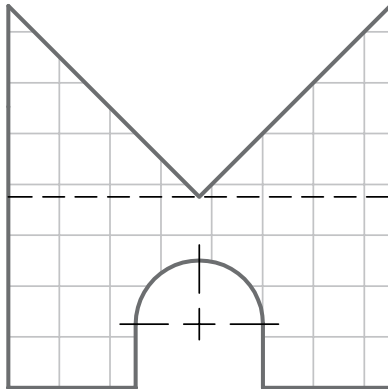
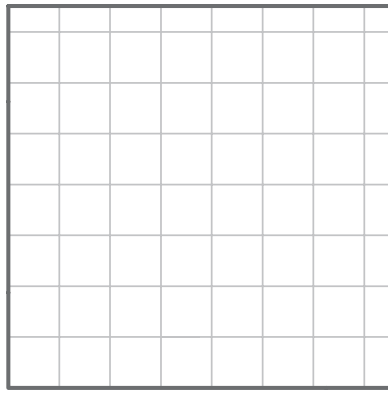

SKETCH THE MISSING VIEW. ALL LINES MUST FIT INSIDE THE EXISTING BOUNDARIES.
ROUND UP TO THE NEAREST GRID SQUARE.

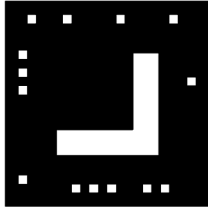
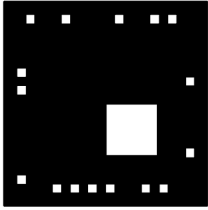

ORTHOGRAPHIC
PROJECTION

CHAPTER 02
EXERCISE 08

NAME:

DATE:

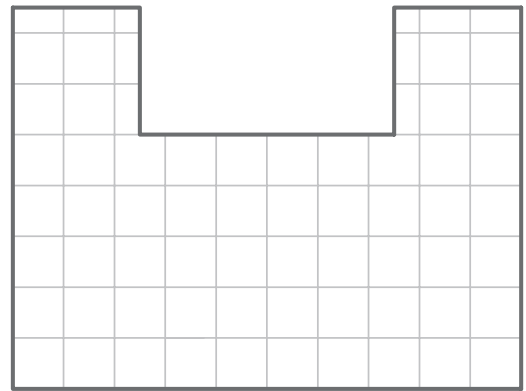
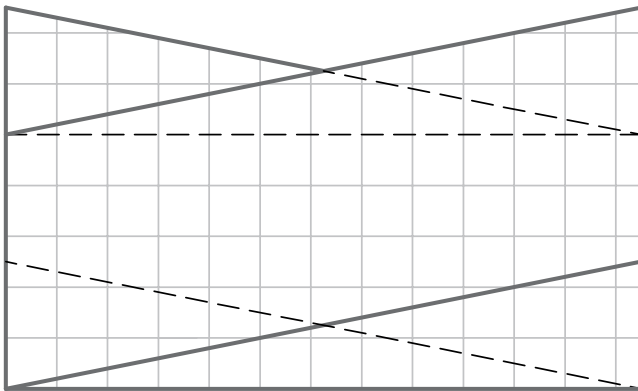
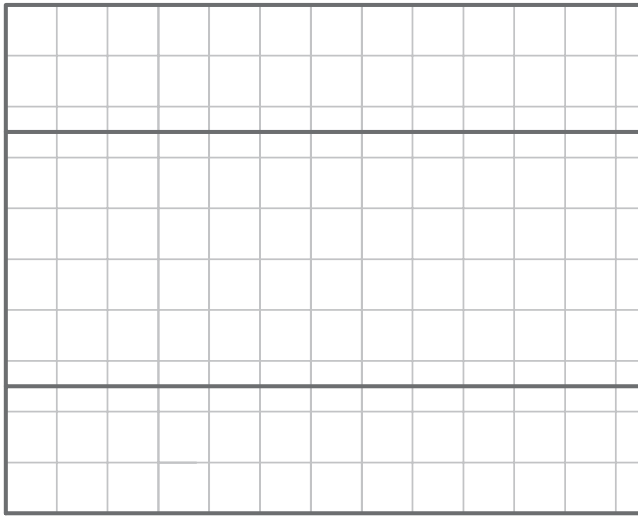

SKETCH THE MISSING VIEW. ALL LINES MUST FIT INSIDE THE EXISTING BOUNDARIES.
ROUND UP TO THE NEAREST GRID SQUARE.

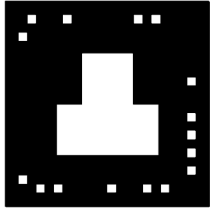
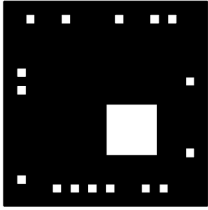

ORTHOGRAPHIC
PROJECTION

CHAPTER 02
EXERCISE 09

NAME:

DATE:

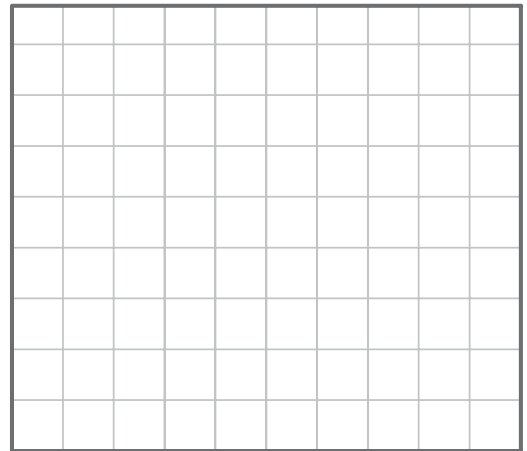
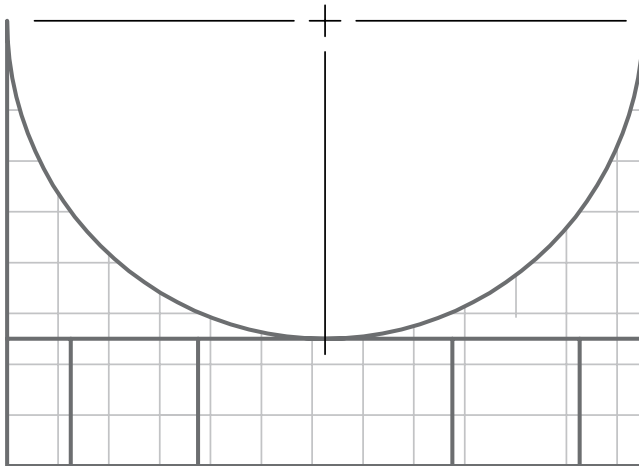
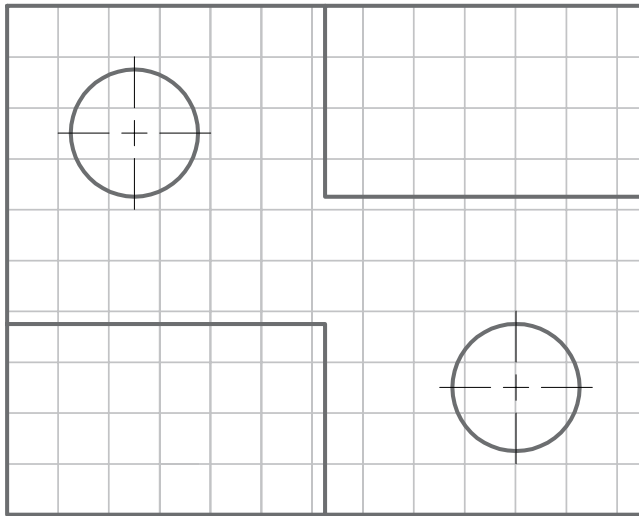

SKETCH THE MISSING VIEW. ALL LINES MUST FIT INSIDE THE EXISTING BOUNDARIES.
ROUND UP TO THE NEAREST GRID SQUARE.

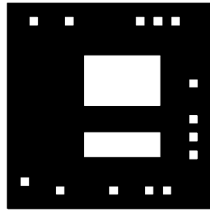
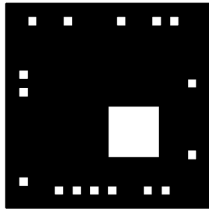

ORTHOGRAPHIC
PROJECTION

CHAPTER 02
EXERCISE 10

NAME:

DATE:

The main area of the page is a large grid for sketching. On the right side of the grid, there is a 3D perspective drawing of a rectangular object. The object is a rectangular prism with a triangular cutout on its right side. The cutout is a triangular prism that has been removed from the right side of the main rectangular prism. The object is drawn with a grid pattern on its visible surfaces to indicate its three-dimensional form.



SKETCH ALL NECESSARY VIEWS TO COMPLETELY DESCRIBE THE OBJECT.
ROUND UP TO THE NEAREST GRID SQUARE.

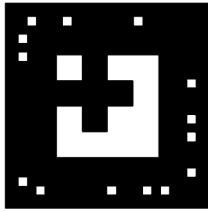
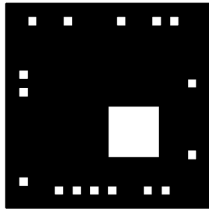

ORTHOGRAPHIC
PROJECTION

CHAPTER 02
EXERCISE 11

NAME:

DATE:

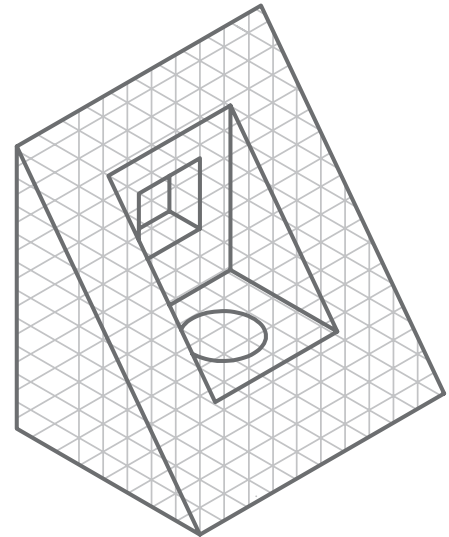
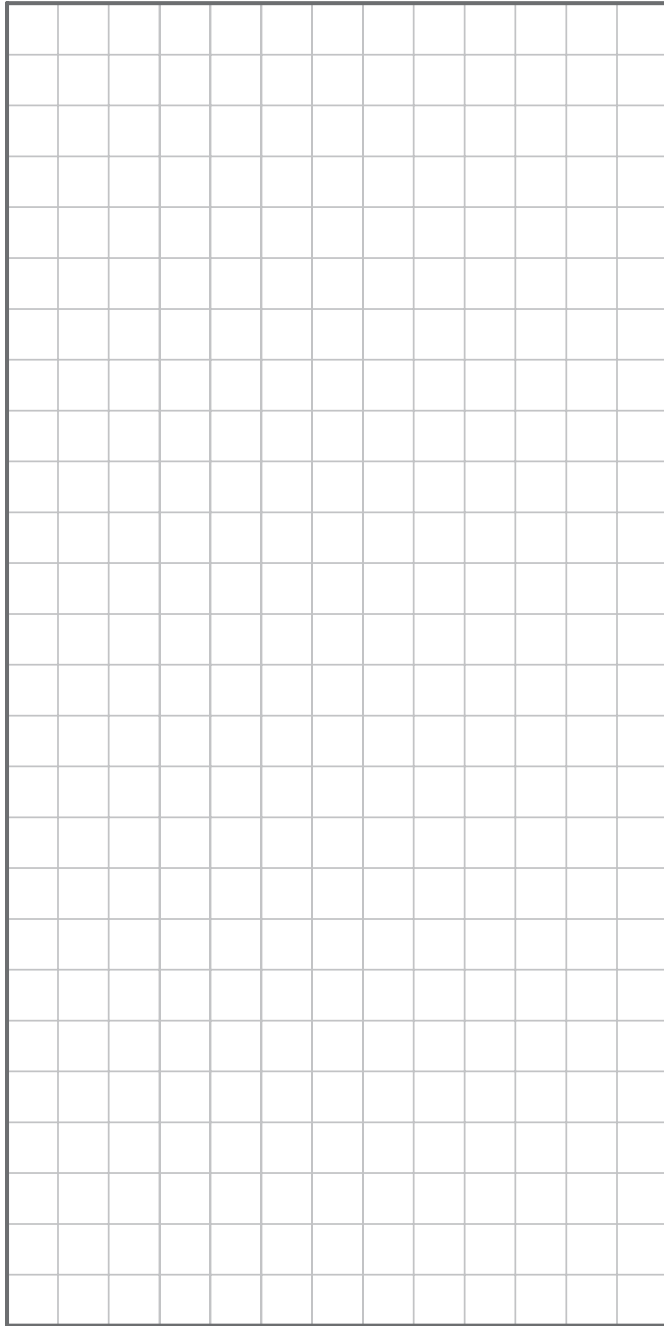

SKETCH ALL NECESSARY VIEWS TO COMPLETELY DESCRIBE THE OBJECT.
ROUND UP TO THE NEAREST GRID SQUARE.

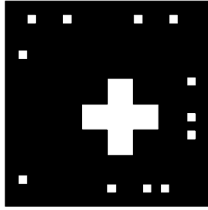
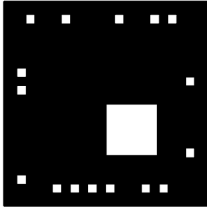

ORTHOGRAPHIC
PROJECTION

CHAPTER 02
EXERCISE 12

NAME:

DATE:

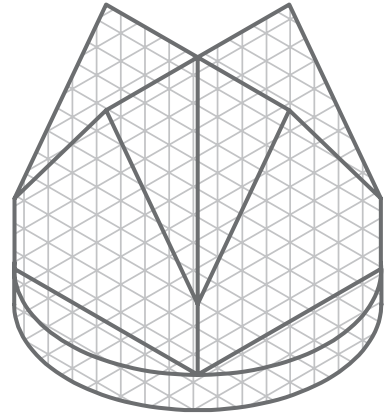
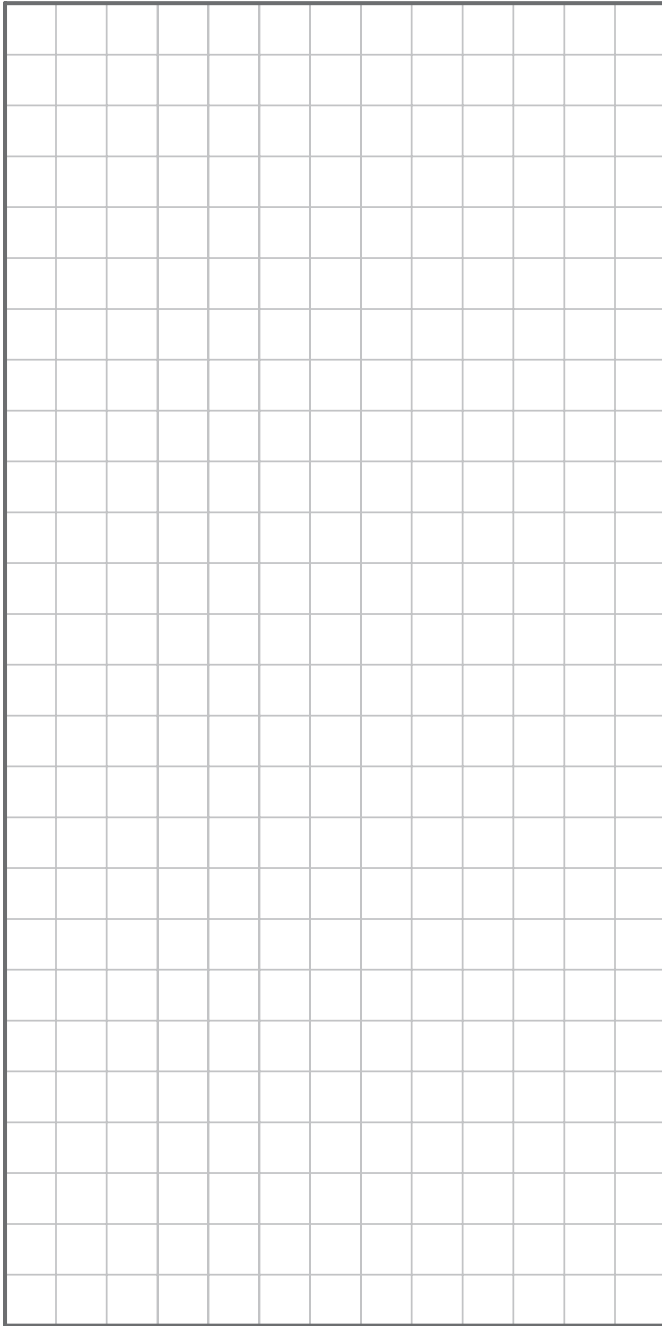

SKETCH ALL NECESSARY VIEWS TO COMPLETELY DESCRIBE THE OBJECT.
ROUND UP TO THE NEAREST GRID SQUARE.

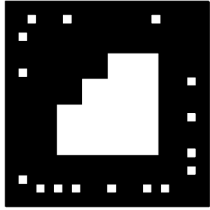
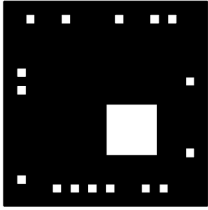

ORTHOGRAPHIC
PROJECTION

CHAPTER 02
EXERCISE 13

NAME:

DATE:

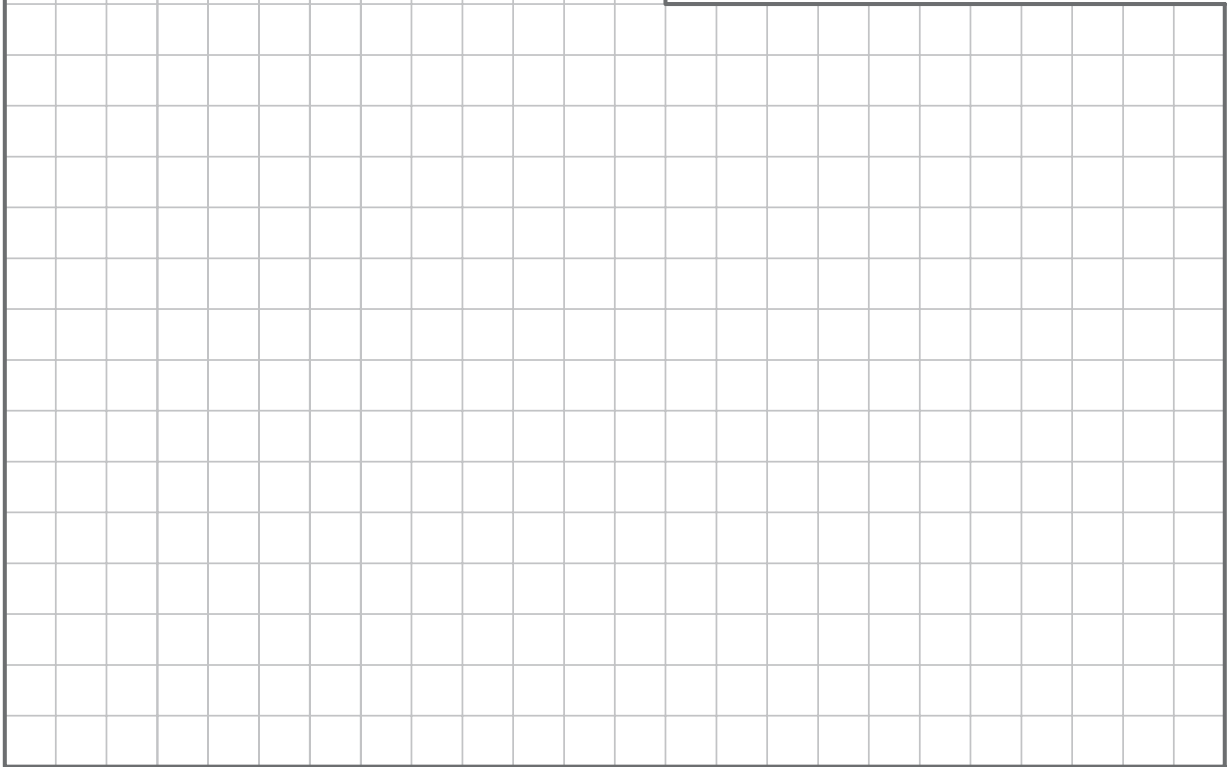
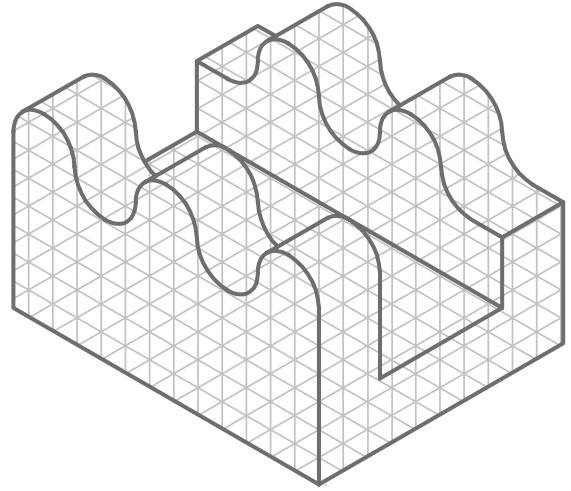

SKETCH ALL NECESSARY VIEWS TO COMPLETELY DESCRIBE THE OBJECT.
ROUND UP TO THE NEAREST GRID SQUARE.

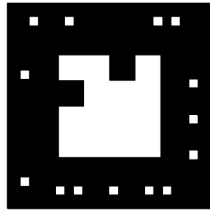
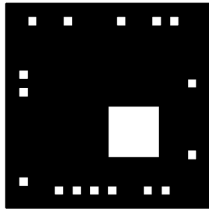

ORTHOGRAPHIC
PROJECTION

CHAPTER 02
EXERCISE 14

NAME:

DATE:



SKETCH ALL NECESSARY VIEWS TO COMPLETELY DESCRIBE THE OBJECT.
ROUND UP TO THE NEAREST GRID SQUARE.

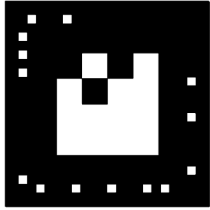
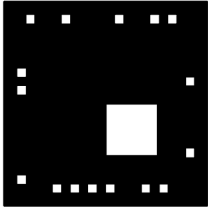

ORTHOGRAPHIC
PROJECTION

CHAPTER 02
EXERCISE 15

NAME:

DATE:

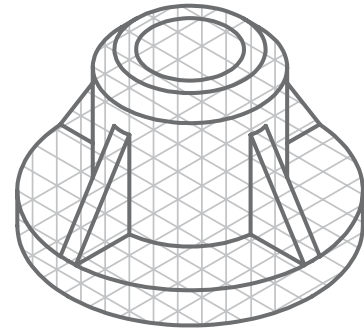
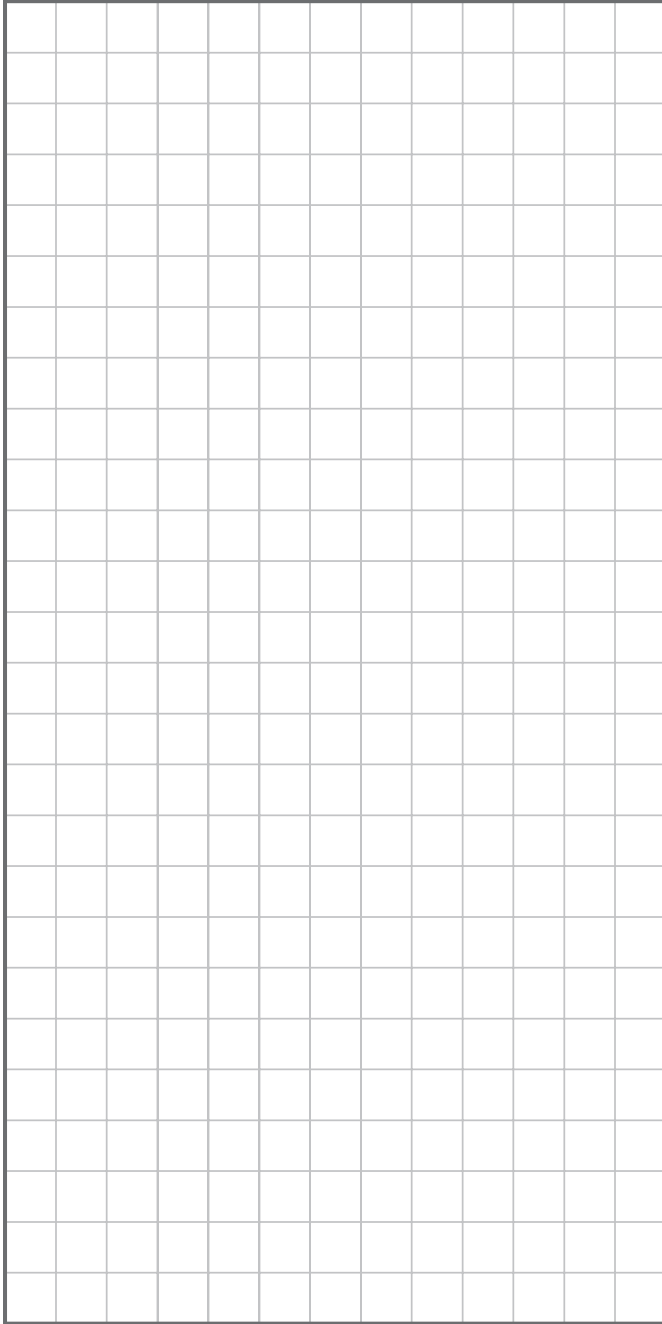

SKETCH ALL NECESSARY VIEWS TO COMPLETELY DESCRIBE THE OBJECT.
ROUND UP TO THE NEAREST GRID SQUARE.