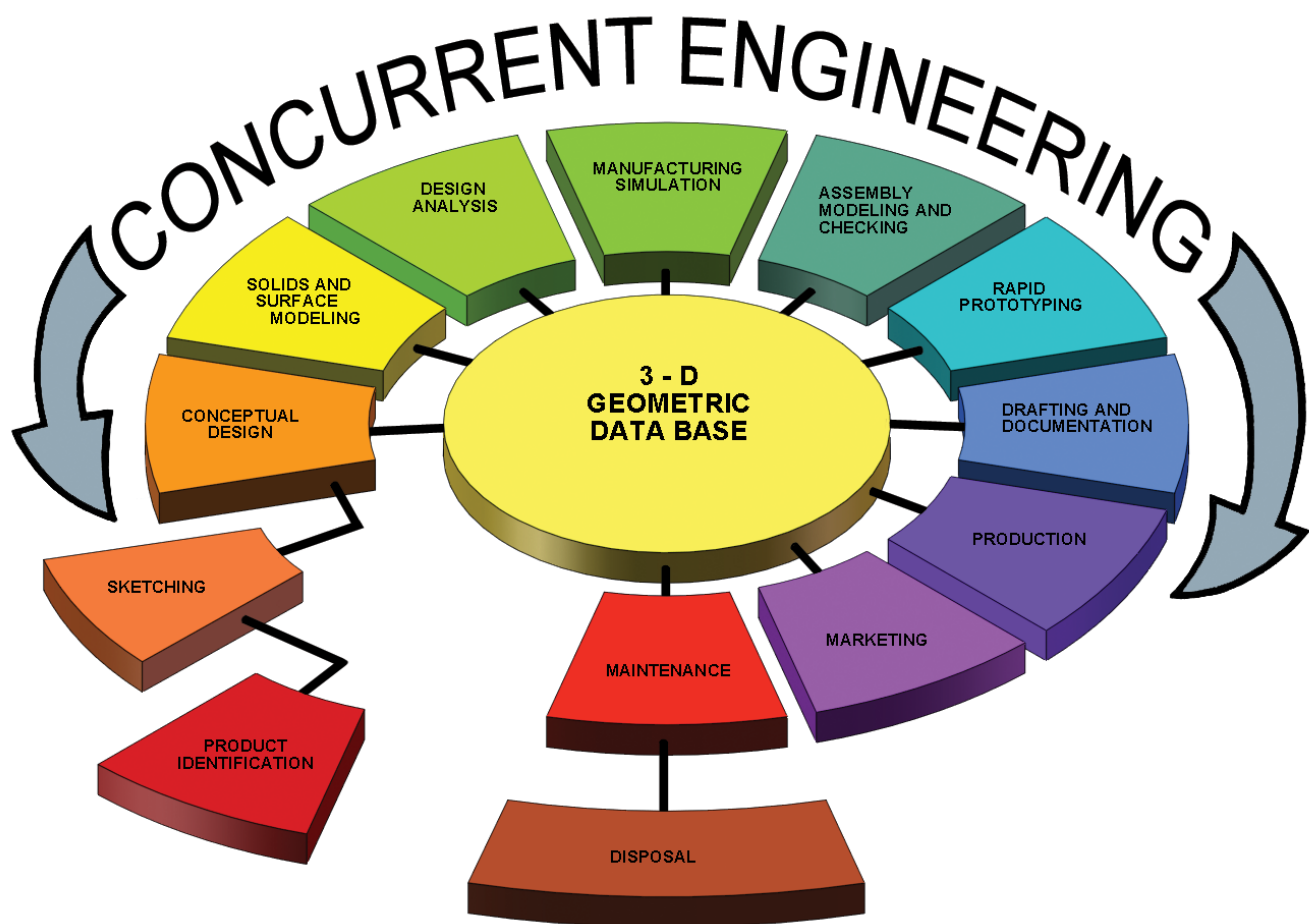


# Engineering & Computer Graphics Workbook

Using SOLIDWORKS® 2015



Ronald E. Barr  
Thomas J. Krueger  
Davor Juricic

Visit the following websites to learn more about this book:



[amazon.com](https://www.amazon.com)

[Google books](https://books.google.com)

[BARNES & NOBLE](https://www.barnesandnoble.com)

# Computer Graphics Lab 2: 2-D Computer Sketching II

## ADVANCED 2-D SKETCHING

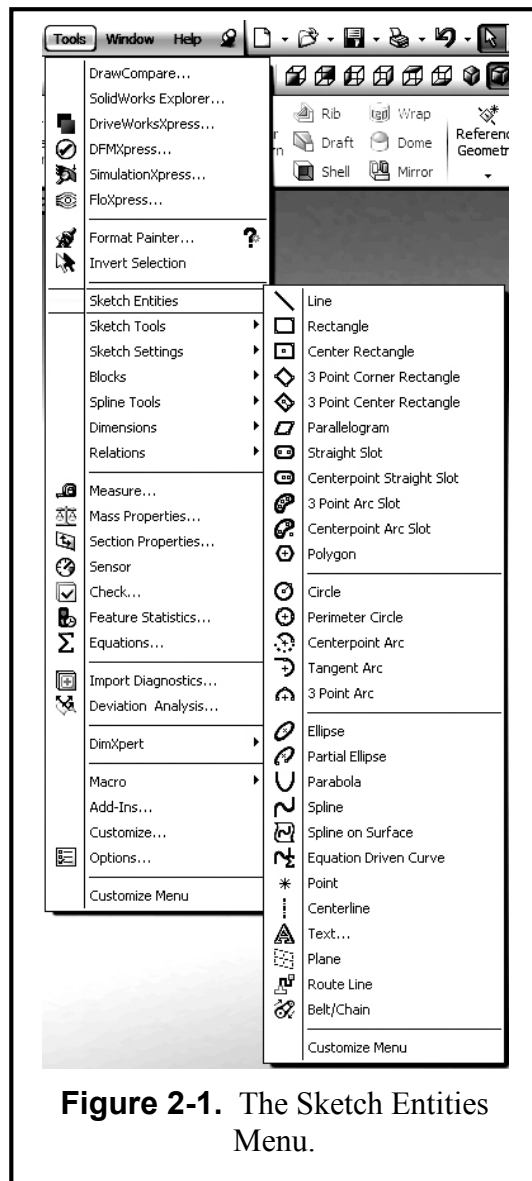
In the first Computer Graphics Lab, you used some of the basic 2-D sketching capabilities of SOLIDWORKS. These first exercises concentrated on using items that were available on the sketching toolbars. You learned how to draw a Line, Circle, Rectangle, Arc, Polygon, Centerline, and Spline. You also learned how to edit the 2-D sketch using Dimensions, Trim, Mirror, Fillet, and Chamfer functions. In this Computer Graphics Lab 2, you will learn some more advanced 2-D sketching and editing features that are available in the vast SOLIDWORKS menu structure.

## SKETCH ENTITY MENU

The sketch entities shown under the sketch tab are not the only ones available. Many of the icons have a small down arrow next to them. Each of these icons have additional options available for your use. These entities are also accessible under the **Tools – Sketch Entities** and are shown in **Figure 2-1**. Here you can find the following 2-D sketch entities:

- Line**
- Rectangles (several options)**
- Parallelogram**
- Slots (several options)**
- Polygon**
- Circle**
- Perimeter Circle**
- Centerpoint Arc**
- Tangent Arc**
- 3 Point Arc**
- Ellipse (several options)**
- Partial Ellipse**
- Parabola**
- Spline**
- Spline on Surface**
- Point**
- Centerline**
- Text**

Some of these 2-D entities are more common in engineering design than others, but hopefully you will have a chance to use each of them somewhere in one of your exercises.



**Figure 2-1.** The Sketch Entities Menu.

## SKETCH TOOLS MENU

All of the 2-D sketch editing functions are found under the **Sketch Tab**. On this menu you will find the following common editing functions:

**Fillet** is used to round a corner with a radius.

**Chamfer** is used to cut a corner at an angle.

**Offset Entities** is used to create another exact copy at a linear distance away.

**Convert Entities** converts an entity from an earlier feature to the current sketch.

**Trim** cuts away a piece of the entity.

**Extend** extends an entity to meet another entity.

**Mirror** copies a pattern around a centerline.

**Dynamic Mirror** first select the entity about which to mirror and then sketch the entities to mirror.

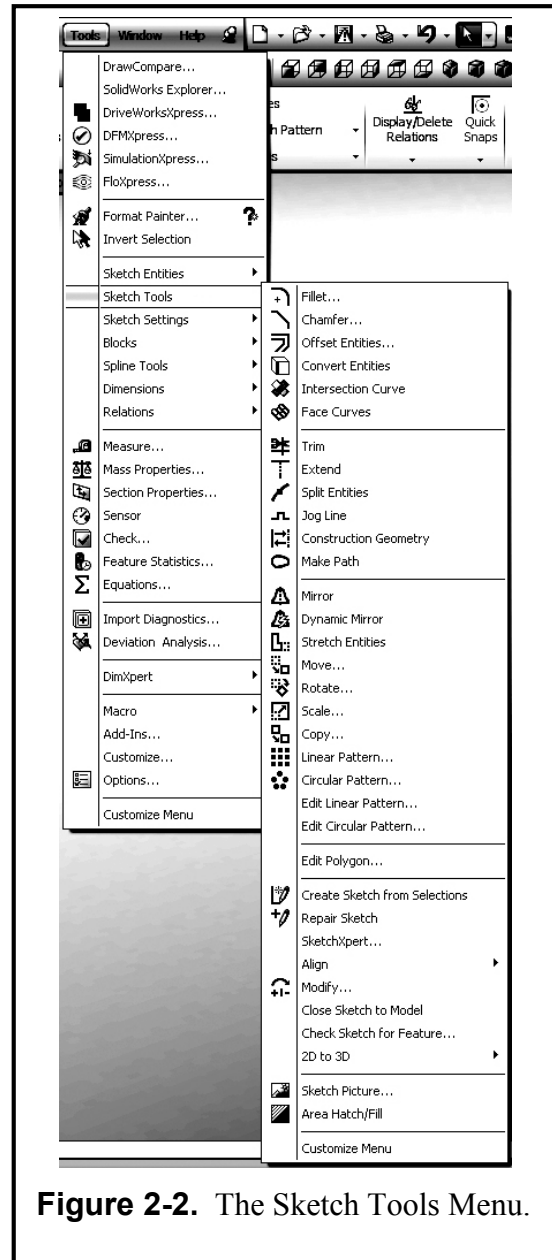
**Jog Line** moves a piece of the line up or down in a rectangular shape.

**Construction Geometry** converts entities to construction geometry or the converse.

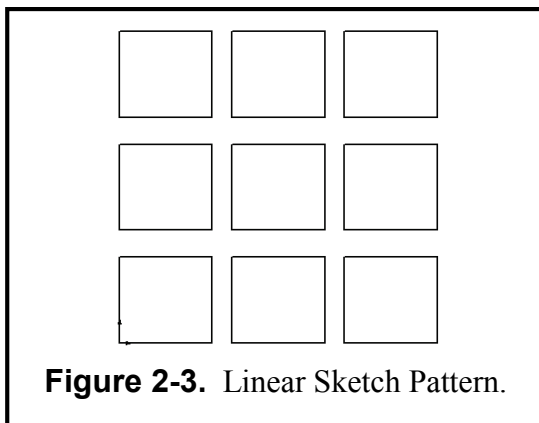
**Linear Sketch Pattern** creates a rectangular array (row X column) of identical entities (see **Figure 2-3**).

**Circular Sketch Pattern** creates a radial (or polar) array of identical entities around a center point (see **Figure 2-4**).

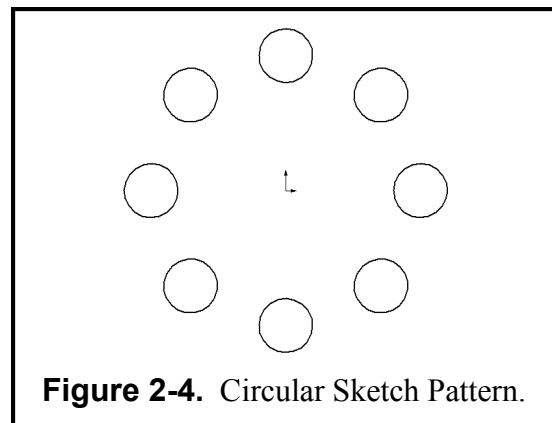
**Align** is used to align a sketch and a grid point.



**Figure 2-2.** The Sketch Tools Menu.



**Figure 2-3.** Linear Sketch Pattern.



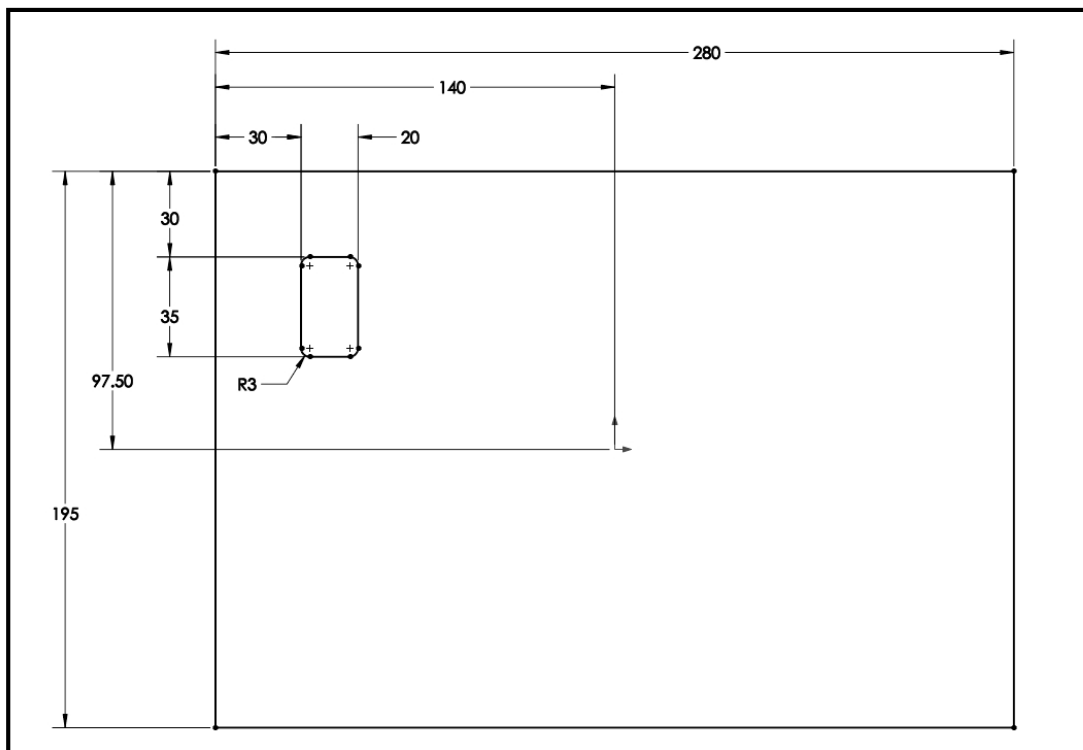
**Figure 2-4.** Circular Sketch Pattern.

## Exercise 2.1: METAL GRATE

In Exercise 2.1, you will design a Metal Grate. The function of a metal grate is such that many identical slots are cut through it. Instead of drawing each slot separately, you will use an advanced sketching feature of SOLIDWORKS and create a rectangular array of these slots. Then you can simply extrude a base to create the beginning grate feature.

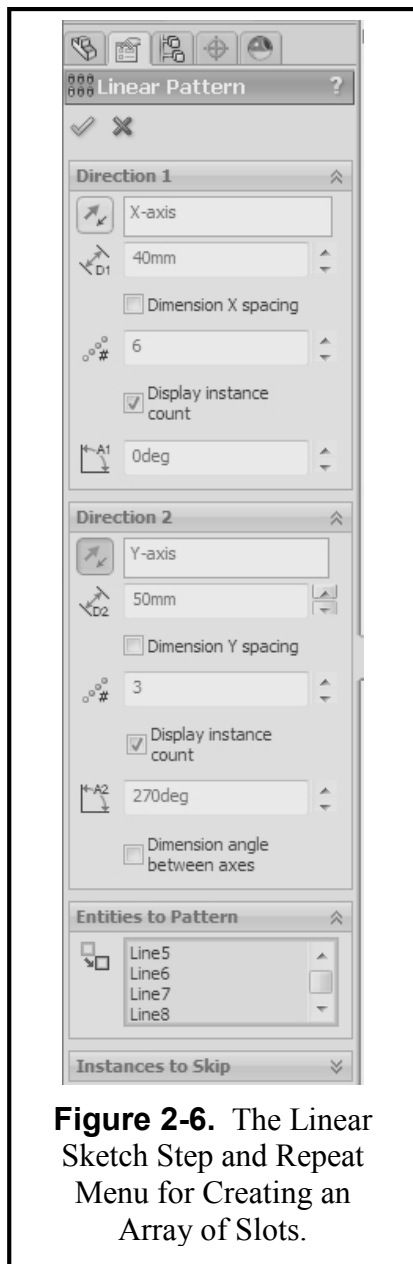
Start by going to your folder and **Open** the file **ANSI-METRIC.prt** because the dimensions of the Metal Grate are in Metric units. Immediately **SAVE AS – METAL GRATE.sldprt**. You will not need a grid for this exercise. Go to **Tools – Options - Document Properties** and click the **Grid/Snap** tab and make sure the “Display Grid” function is **not** checked (√) on, then click the **OK** button. Click the **Front** plane in the Feature Manager for the sketch plane.

Now activate the **Sketch Tab** and click the **Sketch** (pencil) icon to start your sketch. You will first draw two **Rectangles**. The first one is the large outline of the grate and the second one is the initial small rectangular slot that eventually will be arrayed. Refer to **Figure 2-5** below for applying each **Dimension**. The overall size of the grate is **280 mm** by **195 mm**, and it is centered about the origin with its other two dimensions (**140** and **97.5**). The small slot is **20 mm** by **35 mm** and is **30 mm** below the top and **30 mm** to the right of the upper left corner. *Note:* After all the dimensions are applied, the lines turn black. This means that the geometry is completely fixed and constrained. Using the fillet command, add **3mm fillets** to the four corners of the small rectangle.

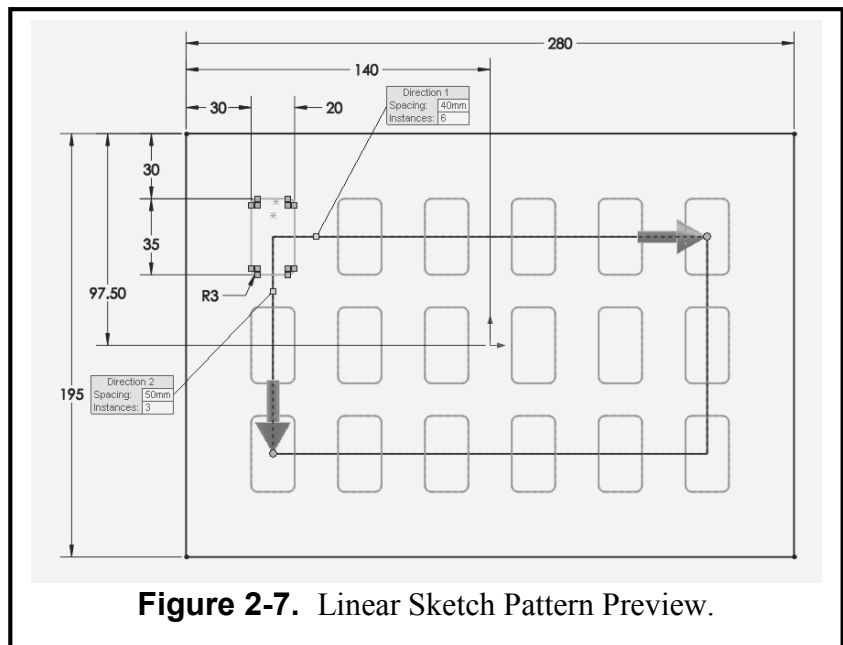


**Figure 2-5.** The Beginning Dimensions for the Metal Grate Centered at the Origin.

Now select the **Linear Sketch Pattern** icon in the sketch entities toolbar or pull down **Tools**; select **Sketch Tools** and then pick the **Linear Pattern** option. The “Linear Pattern Repeat” menu pops onto the screen. The Entities to Pattern box at the bottom of the menu is prompting you to select the lines and fillets of the small rectangle. The settings for this rectangular array operation are shown in **Figure 2-6** below. “Direction 1” is horizontal and will have **6** repeats. The horizontal spacing is **40** mm and the angle is **0** degrees. To activate “Direction 2” change the number of repeats to **3**. You will then be able to change the vertical spacing to **50** mm and the angle to **270** degrees. Notice that as you make adjustments to the linear table a **Preview** of the operation is shown before it is officially executed. If it is correct, click the **OK** button to complete the array. You should have a 6 x 3 array of slots that now can be extruded. You will have to click on the arrows to the left of the Y-axis button under Direction 2 to make the boxes drop below and onto the metal grate. Your pattern preview should look like the image in **Figure 2-7**.



**Figure 2-6.** The Linear Sketch Step and Repeat Menu for Creating an Array of Slots.



**Figure 2-7.** Linear Sketch Pattern Preview.

Select the **Features Tab** and select **Extruded Boss/Base** Key in the following parameters:

Type of Extrusion = **Blind**

Distance 1 = **5** mm

Then click the green (√) check to close the menu. You will now have the base solid model of the grate, as shown in **Figure 2-8** in a **Trimetric** view.

The next step for the Metal Grate is to add a lip to the metal grate in order to provide a support when attached to the wall air duct. Click on this front surface of the Metal Grate. It should highlight *blue*. Then click on the **Sketch** tab and select the **Sketch Command** to add another sketch to the design. You have already drawn the outer rectangular profile, so you will borrow from it for the outer edge of the lip. Click the **Convert**

sketch edit icon (it looks like a cube with a blue vertical edge). The outer lines now become part of your active sketch. Notice that they are all black lines since the geometry is already fixed.

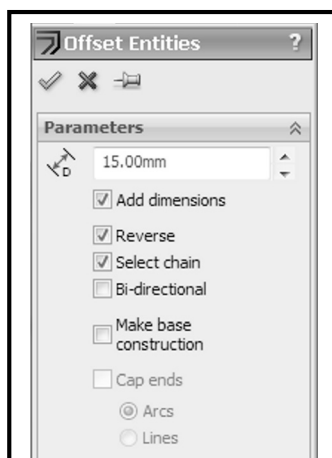
Now click the top converted line (it turns *cyan*) and then click the **Offset Entities** icon (it looks like two bent parallel lines). Key in the offset value of **15 mm** and make sure the **Select Chain** box is checked (✓). If the 15 mm offset is previewed on the outside, check (✓) the “**Reverse**” box in the menu box so the offset is to the *inside* of the original lines and then click the green (✓) checkmark to create the offset, as shown in **Figure 2-10**. Also, notice that the offset command places a small 15 mm dimension on your sketch to indicate the offset value. You could now simply click on that dimension directly, key in a new dimension value, and instantly change the offset to a new value. But for now leave it at 15 mm. Fillet the inside corners of the offset pattern to **5mm** as shown in **Figure 2-10**.

Before you perform the Extrude command you may want to go to an Isometric view in order to see which direction you are extruding. Select the **Features** icon and select **Extrude**. When the **Extrude** menu appears, key in the following parameters:

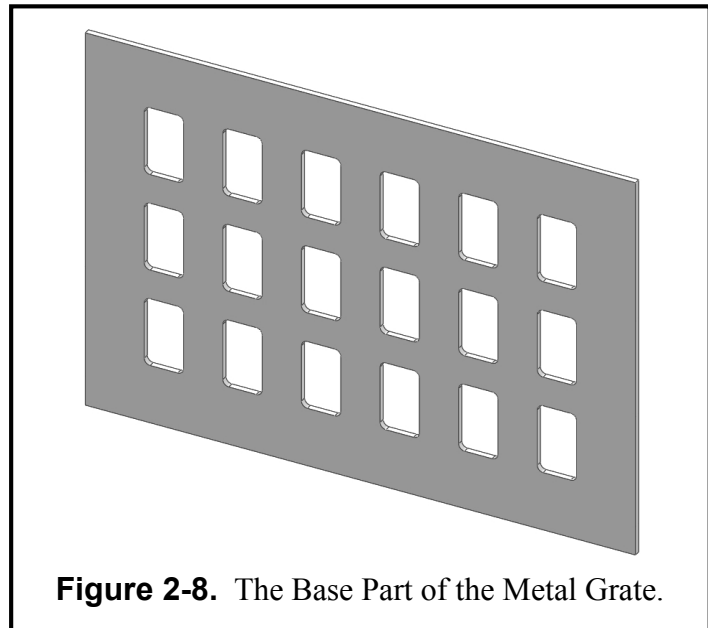
Type of Extrusion = **Blind**

Distance 1 = **5 mm**

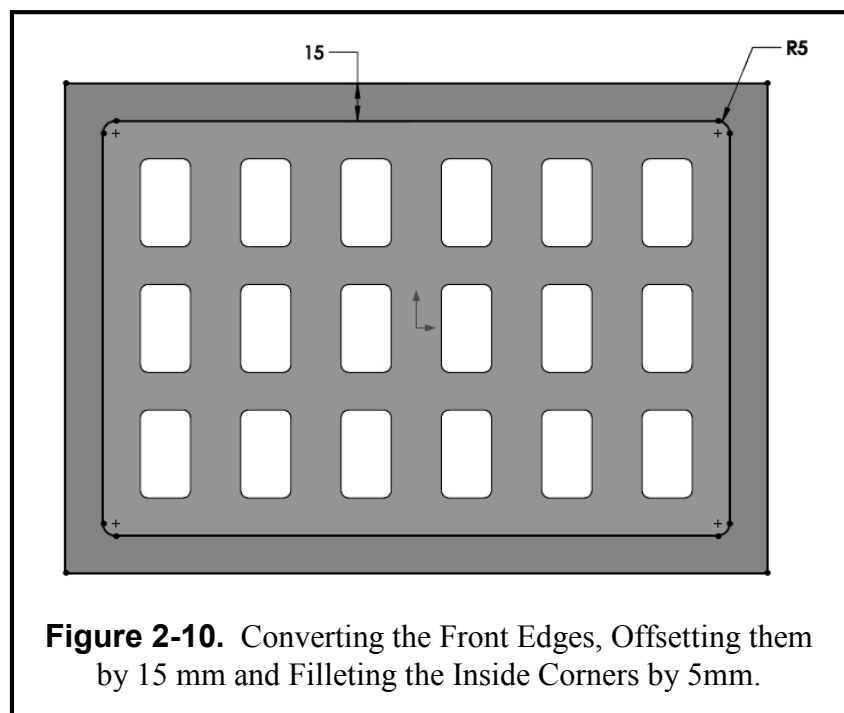
Click the green (✓) check to complete the boss.



**Figure 2-9** Offset Entities.



**Figure 2-8.** The Base Part of the Metal Grate.

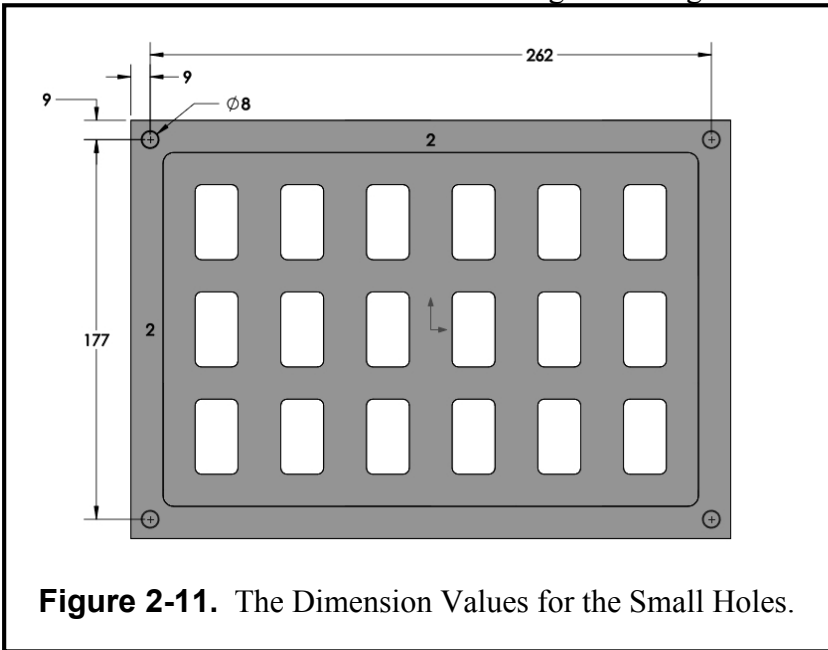


**Figure 2-10.** Converting the Front Edges, Offsetting them by 15 mm and Filleting the Inside Corners by 5mm.

Now you need to add four attachment holes to the corners of the grate. **Select** the raised rim (it will turn *blue*). Click on the **Sketch Tab** and activate the **Sketch icon** and draw a **Circle** in the upper left corner. Use the **Dimension** values supplied in **Figure 2-11** for the circle diameter (**8 mm**) and position from the corner (**9mm x 9mm**).

Now draw three more **Circles** in the other three corners. **Dimension** them to have the same diameter (**8**) and same relative position (**9 x 9**) from each corner. *Or*, now that you are an expert with a rectangular array, use the **Linear Sketch Pattern** operation instead. If you use this function, then the horizontal distance of the **2** items is **262 mm** and the angle is **0** degrees. The vertical distance of the **2** items is **177mm** and the angle is **270** degrees. *Either way*, when you are finished you should have circles at the four corners and click the green (✓) check to execute the Linear array.

Change your viewpoint to a Trimetric view. Now activate the **Features** icon and select **Extruded Cut**. Select the extrude type to be **Through all** and click the green (✓) check to execute the cut. The four corner attachment holes are now created on the grate.

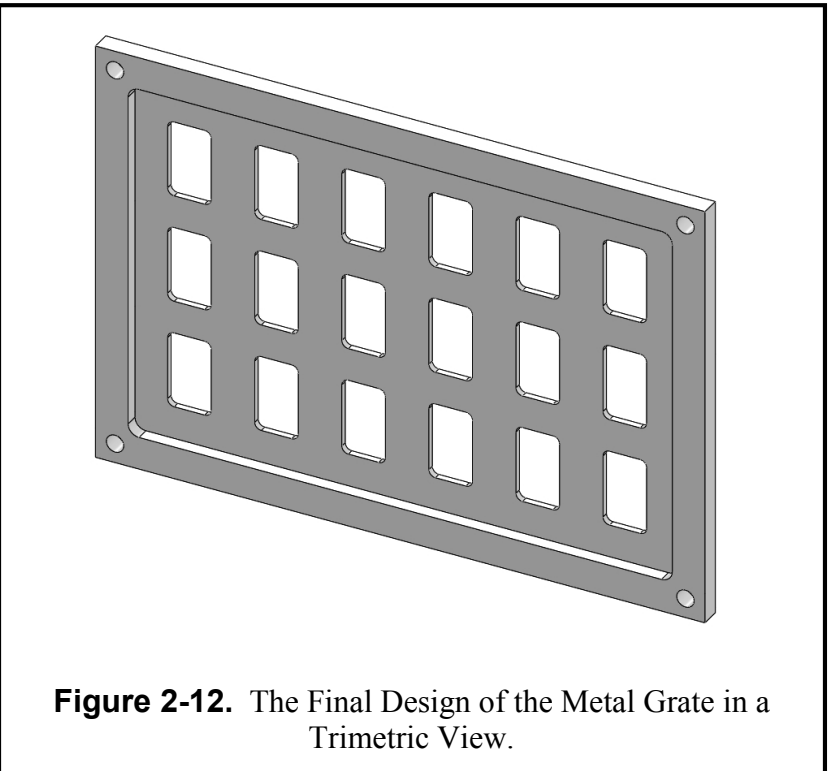


**Figure 2-11.** The Dimension Values for the Small Holes.

The part is now complete and you can view the lip feature more clearly by using the **Rotate View** icon as shown in **Figure 2-12**.

If you would like to change the color of your model, click on the model name in the Feature manager tree and then select the colored ball in the menu bar. You can then assign any color you wish to the model.

Return to a **Trimetric View** of your part as shown in **Figure 2-12**. You should now save your model. Pull down **File**, select **Save As**,

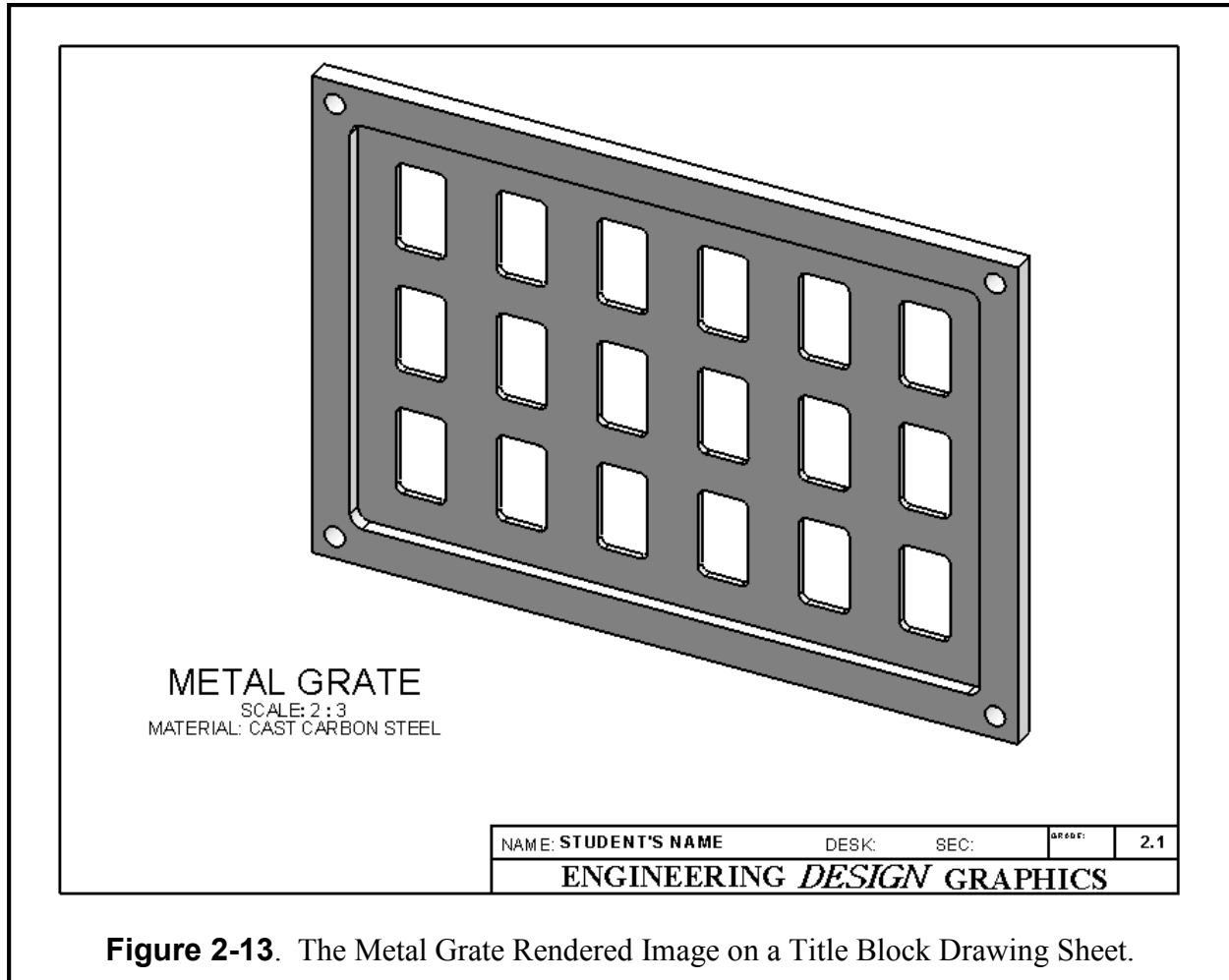


**Figure 2-12.** The Final Design of the Metal Grate in a Trimetric View.



type in the part name **METAL GRATE.sldprt**, and then click **Save**. Open your copy of **TITLE BLOCK – METRIC.drwdot** and immediately **SAVE AS – METAL GRATE.slddrw**. Now insert the rendered Metal Grate image into your **Title Block** drawing sheet that was created in Chapter 1 and **Print** it on this sheet (see **Figure 2-13**).

**Print** a hard copy to submit to your lab instructor.



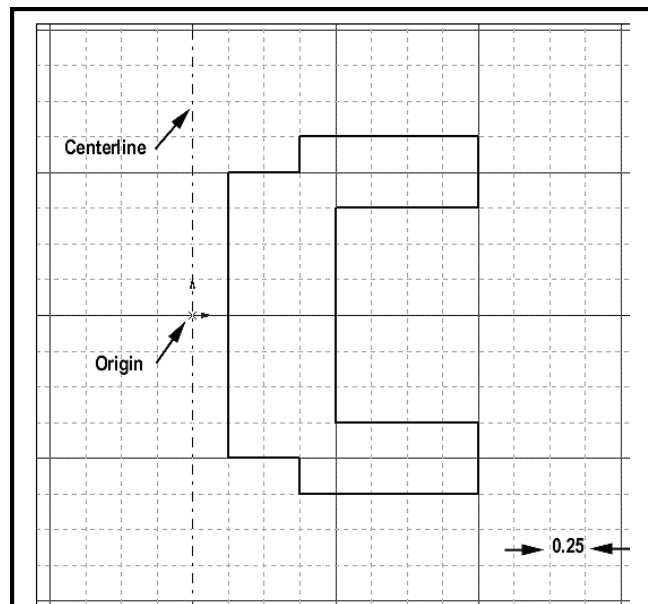
**Figure 2-13.** The Metal Grate Rendered Image on a Title Block Drawing Sheet.

## Exercise 2.2: TORQUE SENSOR

In Exercise 2.2 you will design a Torque Sensor casing. Since it is a circularly symmetrical object, you will employ some of the advanced editing features like circular array. Go to your folder and **Open** the file **ANSI-INCHES.prt**, and immediately **SAVE AS – TORQUE SENSOR.sldprt**. Select the **Tools, Options, Document Properties** menus and Select **“Grid/Snap.”** Make the following settings on this menu: **“Major grid spacing” = 1.00**, **“Minor lines per major” = 4**. Also go to System Snaps and make sure **“Display Grid”** and the **“Snap”** functions are checked (✓) on, then click the **OK** button. Make sure the **Units** are in **Inches**. Then click **OK**.

The circular features of the Torque Sensor are on the top and bottom surfaces. But the main body is also round and can be created by a 360 degrees revolution of a profile that has been drawn on a frontal plane. So click on the **Front** plane in the Feature Manager tree. Click on the **Sketch Tab** and select the **Sketch Icon** and the sketching grid appears with minor grids spaced every 0.25 inches. Also make sure you are viewing this from the **Front** view orientation.

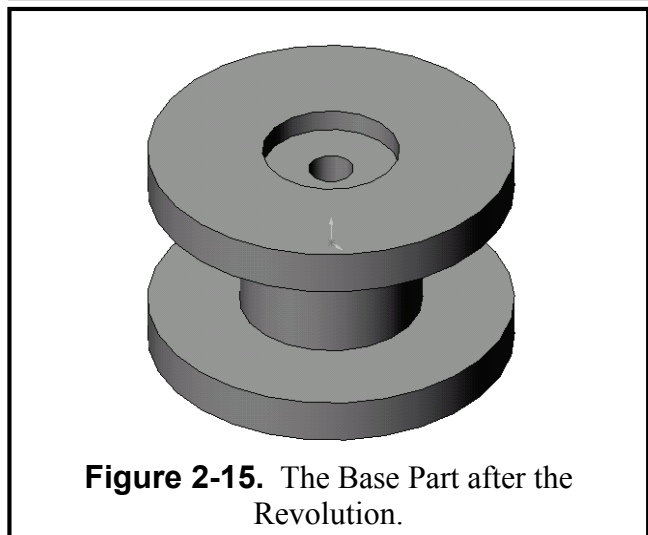
First draw a **Centerline** vertically through the origin. Next, use the **Line** tool to sketch the completely enclosed profile that is depicted in **Figure 2-14**. This design will yield a part that is 2.50 inches tall and 4.00 inches in diameter on the top and bottom surfaces.



**Figure 2-14.** The Initial Lines to Revolve for the Base Part.

Go to the **Features** tab and **Select** the **Revolved Boss/Base** icon. Make sure that the centerline is selected for the Axis of Revolution. Key in the full revolution value of **360°** and click the green (✓) check to perform the revolution. The circular base part appears as shown in **Figure 2-15** in an **Isometric** view.

The next design step is to create a circular array of eight holes around a bolt circle on the top surface of the part.

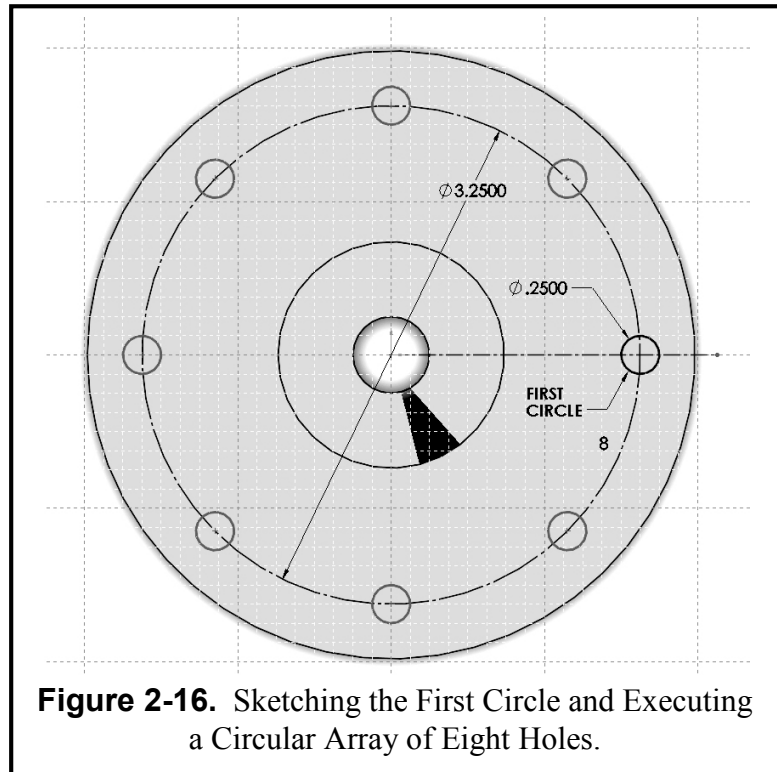


**Figure 2-15.** The Base Part after the Revolution.

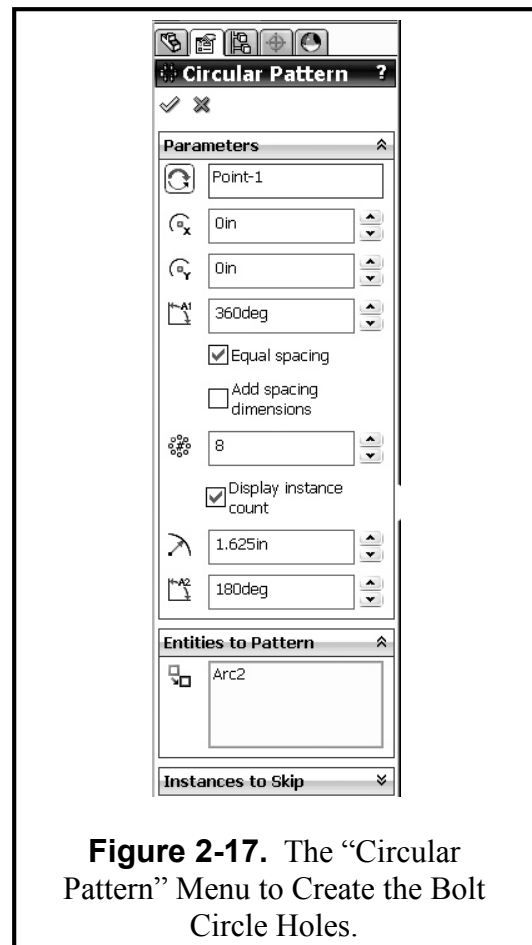
Click on the **top surface of the part** and it should highlight **blue**. Also select a **Top** view orientation. Then select the **Sketch** icon. Draw a **Circle** that is **3.25** inches in diameter, and make sure you select “**for construction**” in the feature manager tree. Then draw a horizontal center line from the origin and to the right. The intersection of these two entities defines the center of the first of eight holes thus resulting in a radius of 1.625. Or you can go to the **Document Properties** menu and on the **Grid/Snap** tab change the “Minor lines per major” value to **8**, thus resulting in a one-eighth inch grid. Also on the **Units** tab change the decimal places to **3**. Click **OK** and the grid should now be updated to the new values. Now locate the center of the first **Circle** on the grid and draw it with a diameter of **0.25**. Use **Figure 2-16** to aid you.

**Select** the circle (it should highlight **blue**). Click on the **down arrow** next to **Linear Sketch Pattern** to select the **Circular Sketch Pattern** option. The “Circular Pattern” menu appears on the screen. Referring to **Figure 2-17**, set the parameters for this circular array. The “Radius” is **1.625** from the center (0,0). The “Step Number” is **8** for a “Total angle” of **360°**. The spacing is “Equal” checked (✓) on. Click **Preview** to see if everything is correct, and then click the **OK** button. You now have a bolt circle of 8 holes as previewed earlier in **Figure 2-16**. You are now ready to cut these holes through the entire base part.

Switch to the **Shaded** model mode and to an **Isometric** view to better see the next operation. Select the **Features** tab and select **Extruded Cut**. On the “Cut Extrude” menu select **Through all** for the direction and click the green (✓) check to execute the cut extrusion all the way through the model. Use the **Rotate View** icon to see that the holes are indeed



**Figure 2-16.** Sketching the First Circle and Executing a Circular Array of Eight Holes.

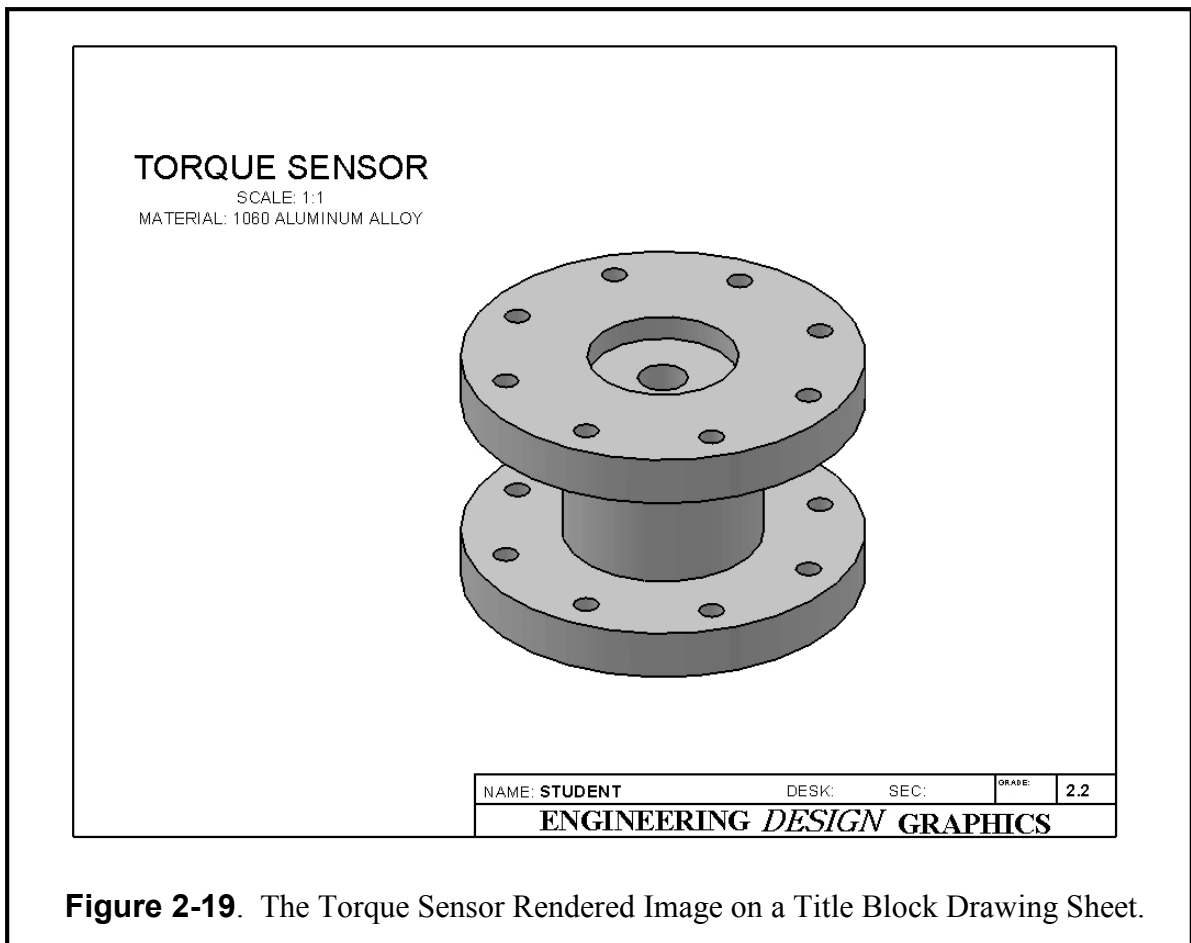
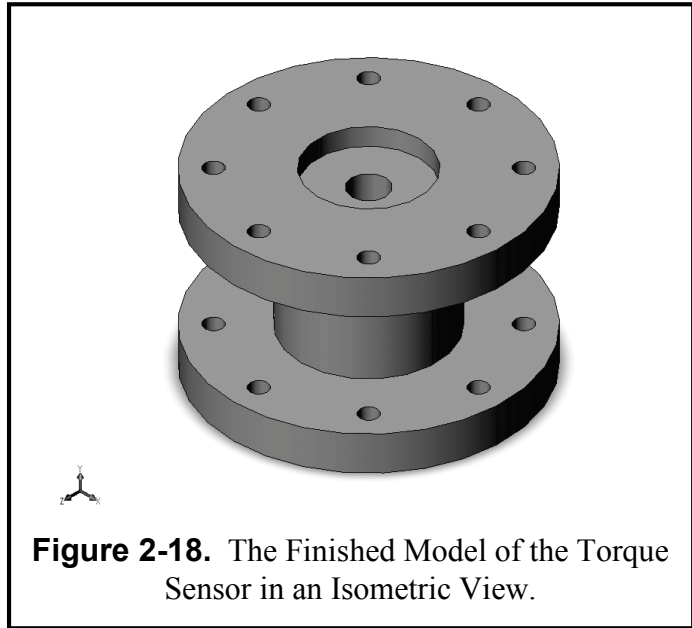


**Figure 2-17.** The “Circular Pattern” Menu to Create the Bolt Circle Holes.

all the way through the bottom of the model. If so, then the model is complete as shown in **Figure 2-18**.

If you would like to change the color of your model, click on the model name in the Feature manager tree and then select the colored ball in the menu bar. You can then assign any color you wish to the model.

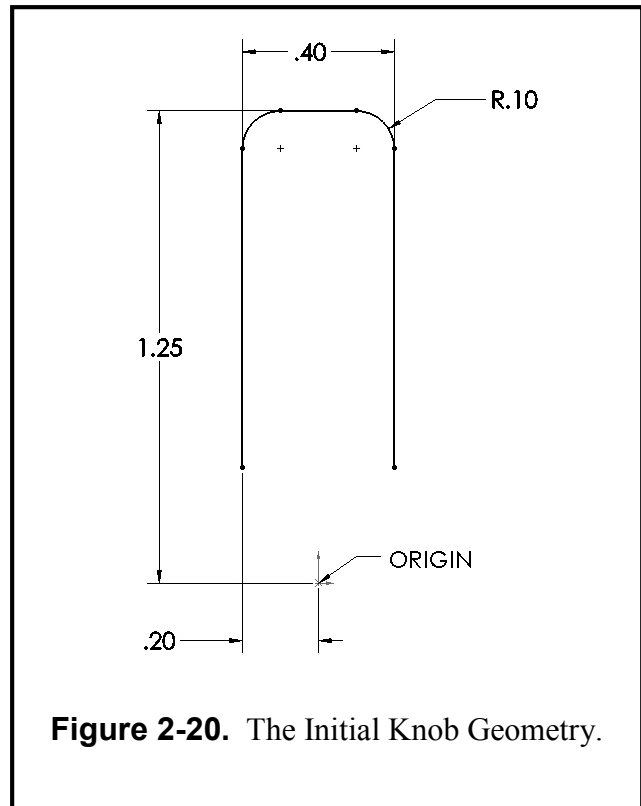
You should now save your model. Pull down **File**, select **Save As**, type in the part name **TORQUE-SENSOR.sldprt**, and then click **Save**. Open your **TITLE BLOCK – INCHES.drwdot** and **SAVE AS: TORQUE SENSOR.sldrw**. Now insert the rendered Torque Sensor image into your **Title Block** drawing sheet that was created in Chapter 1 and **Print** it on this sheet (see **Figure 2-19**).



## Exercise 2.3: SCALLOPED KNOB

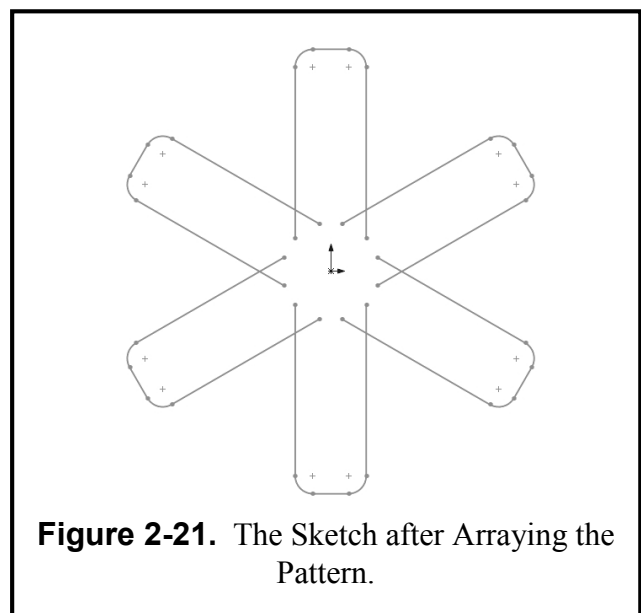
In Exercise 2.3, you will design a Scalloped Knob that has some complicated geometry around its edges. This particular knob design will be a hexagonal type. Since the hexagonal features are equally spaced around the center of the knob, you can use a circular array function.

Start by going to your folder and **Open** the file **ANSI-INCHES.prtdot** and immediately **SAVE AS – SCALLOPED KNOB.sldprt**. Select the **Front** plane for the sketch. Then start a new **Sketch**. Complete the initial geometry of the sketch according to **Figure 2-20**. Using the **Line** tool, draw two vertical lines and cap them off with a horizontal line that touches their top ends. **Fillet** the top two corners with a **0.10** radius. Use the **Dimension** tool to completely fix the geometry by applying the dimensions shown in **Figure 2-20**. Include dimensions that relate to the origin. When the geometry is fixed, all lines turn *black*.



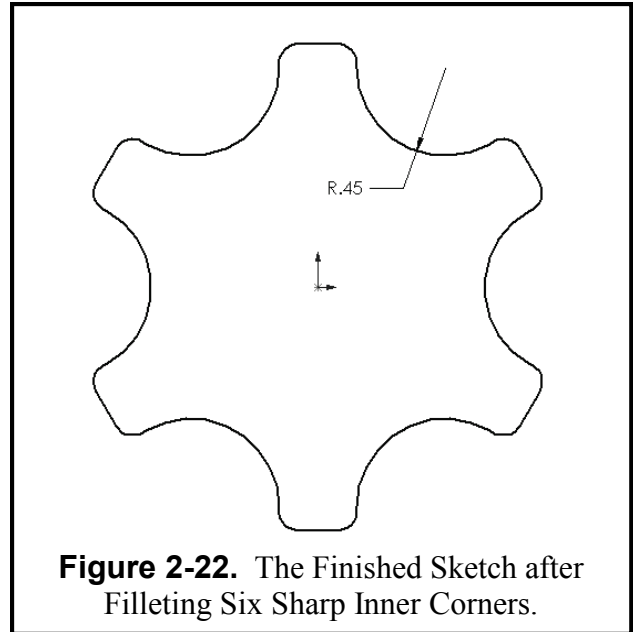
**Figure 2-20.** The Initial Knob Geometry.

Now array this pattern in a circle to form a hexagonal layout. There is a **pull-down arrow** next to the **Linear Sketch Pattern**. When you select it you will see the **Circular Sketch Pattern** option. The “Circular Pattern” menu appears on the screen. Set the “Step Number” to **6** for a “Total angle” of **360°**. The spacing is “Equal” checked (✓) on. Activate the “Entities to Pattern” box and **select the three straight lines and the two fillets**. Click **Preview** to see if everything is correct, and then click **OK**. You now have an array that is the beginning of the sketch for the knob outline. Notice that some of the lines may overlap as can be seen in **Figure 2-21**. You may want to trim the intersecting lines; however, that is not necessary to complete the remainder of the exercise.



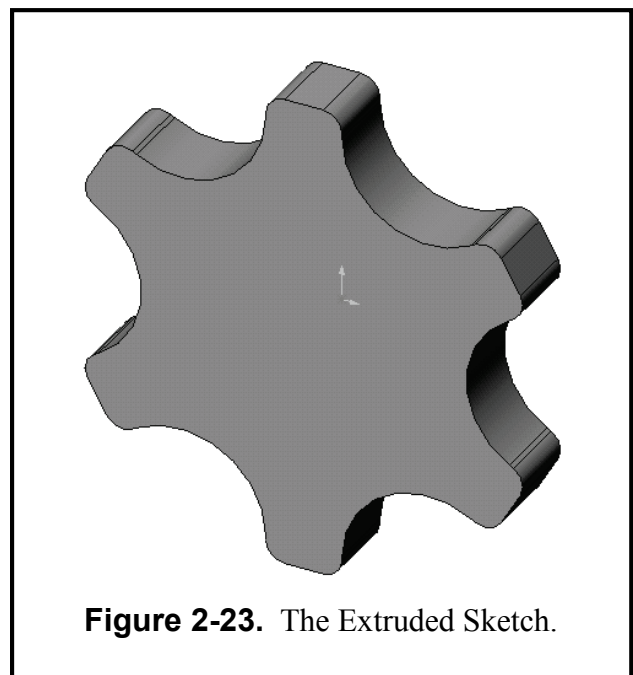
**Figure 2-21.** The Sketch after Arraying the Pattern.

Next, you will fillet the six sharp inner corners to create the scallop effect. Pick the **Fillet** sketch icon and key in a fillet radius of **0.45** in the “Sketch Fillet” parameter box. Now pick two intersecting lines. A large 0.45 radius is made and a small dimension is attached to show the fillet value. Repeat this filleting process on the remaining five sharp inner corners. When you are finished, your sketch should look like **Figure 2-22**.



**Figure 2-22.** The Finished Sketch after Filleting Six Sharp Inner Corners.

Select the **Features** tab and select **Extruded Boss/Base**. Extrude the sketch to a **Blind** depth of **0.375** inches. Click the green check (✓) to close the operation. When finished, view the part in a **Trimetric** orientation as shown in **Figure 2-23**.



**Figure 2-23.** The Extruded Sketch.

You now can finish the part by adding the attachment base. **Click the front surface to highlight it in blue**. Set your view orientation to **Front**. Click the **Sketch** icon and draw a **Circle**, centered at the origin. **Dimension** the circle to be **1.00** inch in diameter. Now draw a **Hexagon** at the origin. Check **Inscribed Circle** and set the diameter to **0.50**. Select the **Features** icon and select **Extrude**. It is advisable to **go to an Isometric view** when executing an extrusion of any kind. Extrude the sketch to a **Blind** depth of **.75** inches away from the front surface.

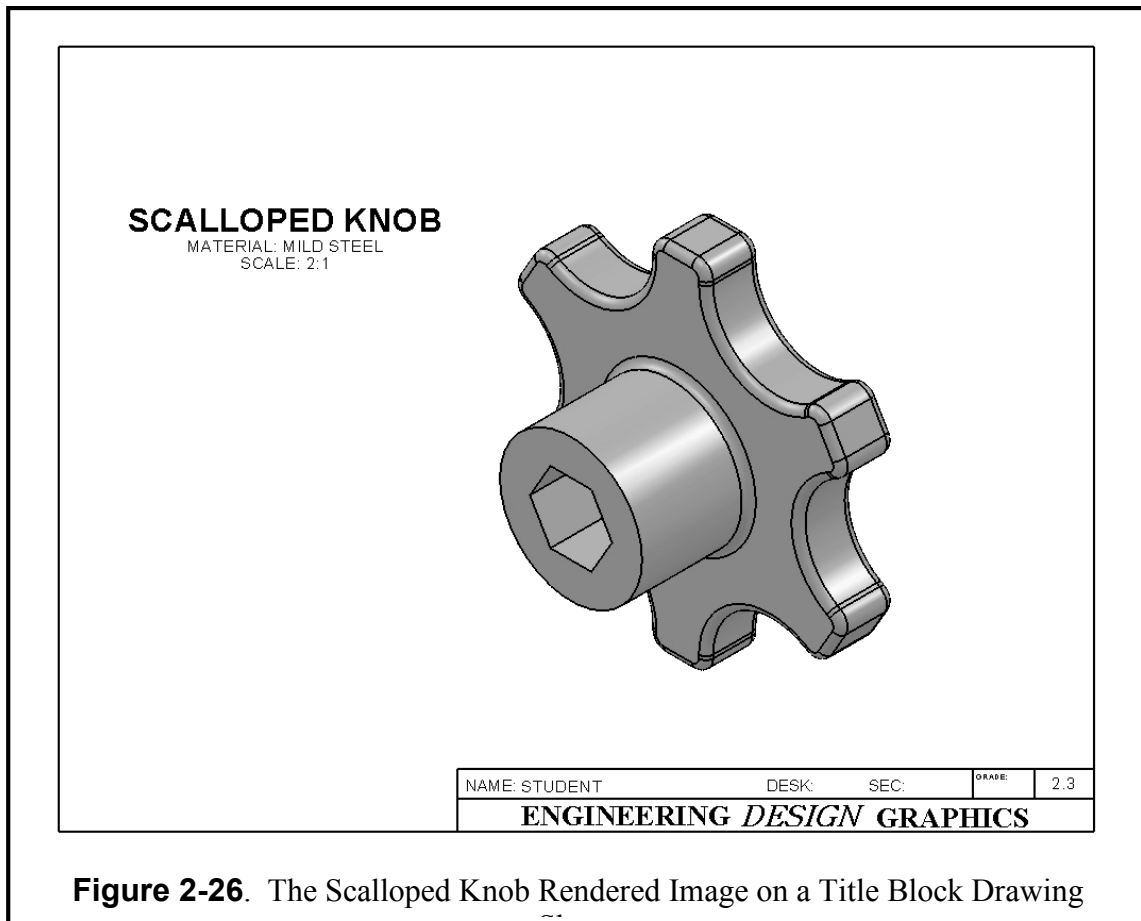
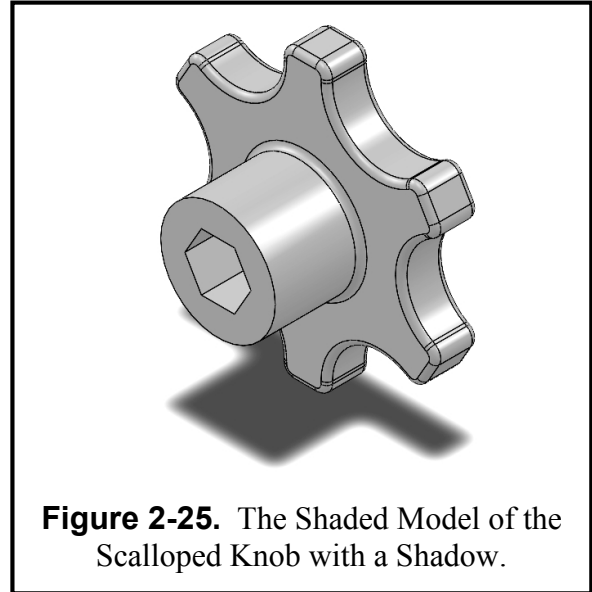
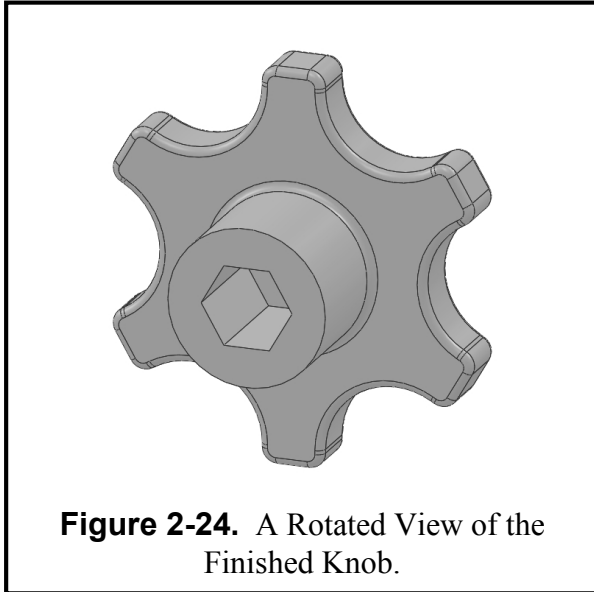
Select the **Dimetric** view to see the inside of the hexagonal hole. **Select** the visible surface of the knob and with the **Features - Fillet** enter **0.05**” to remove the sharp edges of the knob. Repeat the process for the back surface of the knob.

If you would like to change the color of your model, click on the model name in the Feature manager tree and then select the colored ball in the menu bar. You can then assign any color you wish to the model.

Now save your model to your designated folder. Pull down **File**, select **Save As**, type in the part name **SCALLOPED KNOB.sldprt**, and then click **Save**. Open your **TITLE BLOCK – INCHES.drwdot** and immediately **SAVE AS – SCALLOPED KNOB.slddrw**. Now insert

the rendered Scalloped Knob image onto your **Title Block** drawing sheet that was created in Chapter 1 and **Print** it on this sheet (see **Figure 2-26**).

**Print** a hard copy to submit to your lab instructor.



## Exercise 2.4: LINEAR STEP PLATE

In Exercise 2.4, you will design a Linear Step Plate used for linear motion control in machinery. There are a lot of holes on this plate, and you will find the linear array and mirror functions to be quite helpful. Start by going to your folder and **Open** the file **ANSI-INCHES.prt**; immediately **SAVE AS – LINEAR STEP PLATE.sldprt**. Select the **Right Plane** as the drawing plane and the **Right** view orientation to see it head on. Then start a new **Sketch**. Draw a vertical centerline through the origin. Go to **TOOLS – Sketch Tools**, and Select **Dynamic Mirror**. Now sketch the right half of the profile shown in Figure 2-27. Each line drawn on the right side of the centerline will be duplicated on the left. Use the **Dimension** tool to set the geometry by applying the dimensions shown in the **Figure 2-27**, including the dimension to the origin.

Select the **Features** icon and select **Extruded Boss/Base**. On the “Base Extrude” menu, set the extrude parameters as shown in **Figure 2-28**:

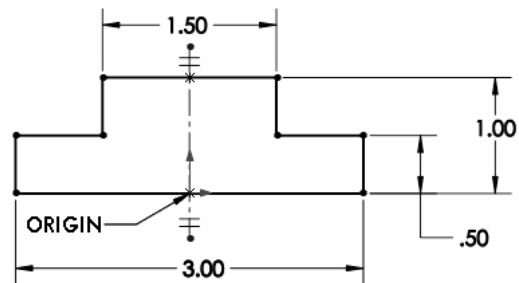
*Direction 1:* **Blind, 4.2000 in.**

*Direction 2:* **Blind, 4.2000 in.**

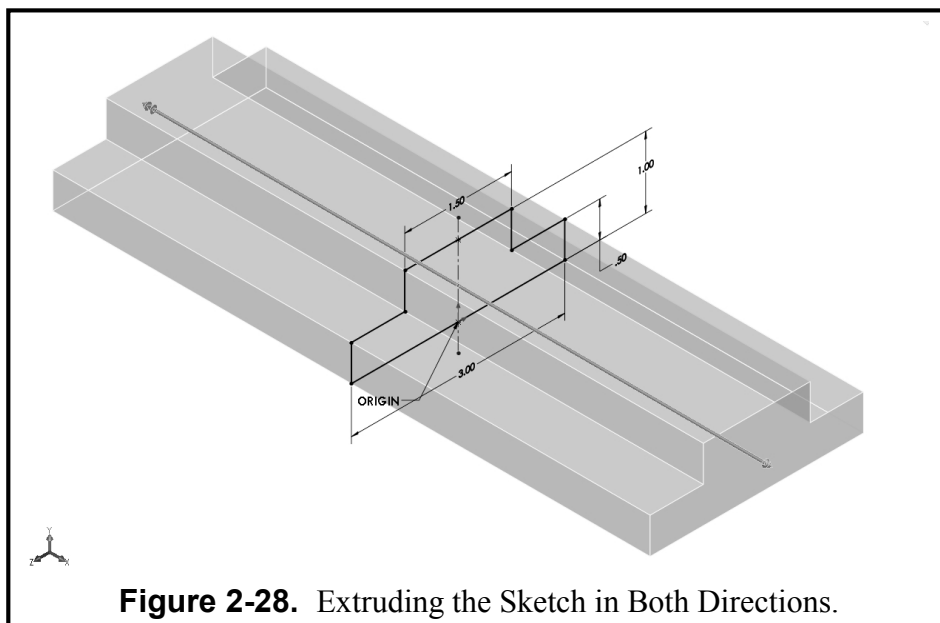
**OR**

**Extrude the Sketch 8.4 in. MID-PLANE**

Notice that you can preview this operation in an **Isometric** view on the screen. Then click the green (✓) check to close the menu and execute the extrusion in two directions. The base part looks like **Figure 2-29**.



**Figure 2-27.** The Initial Sketch for Extruding the Base Part.



**Figure 2-28.** Extruding the Sketch in Both Directions.



Now you will create some linear holes. **Pick the top surface of the small step on the front side** (see **Figure 2-29**). It should highlight *blue*. In a **Top** view, click **Sketch** and draw a small **Circle** on the surface as shown in **Figure 2-30**. Use the **Dimension** tool to add the three dimensions given to fix it:

Diameter = **0.300**  
 From center origin = **1.125**  
 From center origin = **3.000**

Now you will linearly repeat that circle. **Select** the circle (it should turn *cyan*). Select the **Linear Sketch Pattern** icon at the top of the screen. The “Linear Sketch Step and Repeat” menu pops onto the screen. Key in the following parameters:

Direction 1:

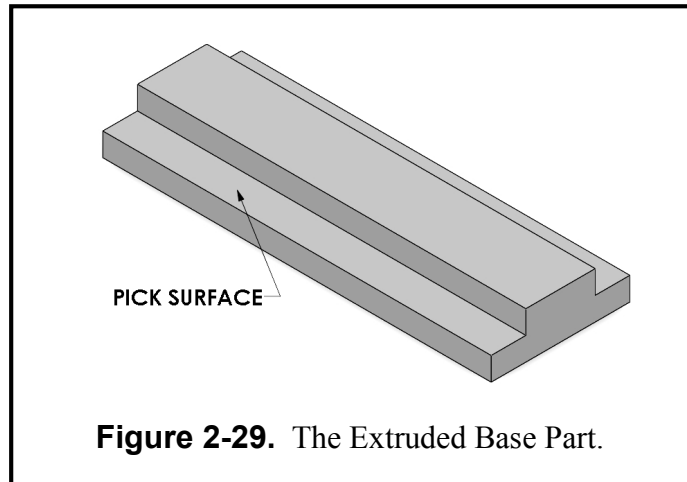
Number = **6**  
 Spacing = **1.2000**  
 Angle = repeat to right side

Direction 2:

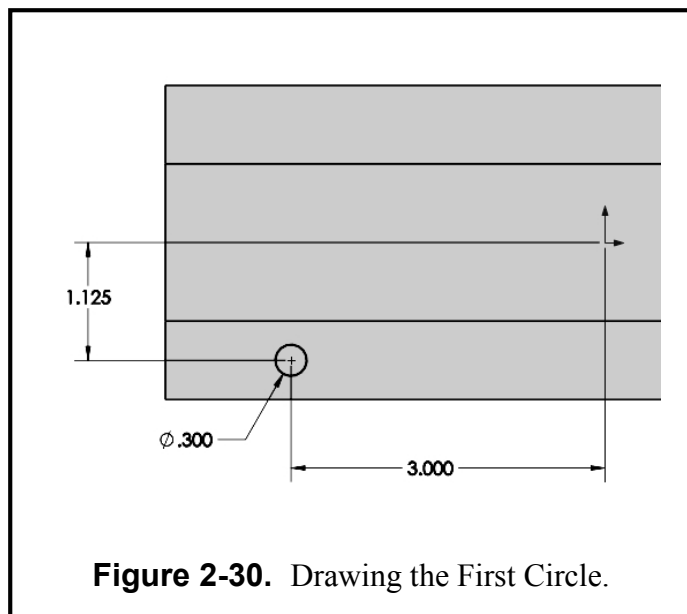
Number = 1

You now should have six circles on the front step surface. You need to add six more circles to the back step surface. You can mirror them.

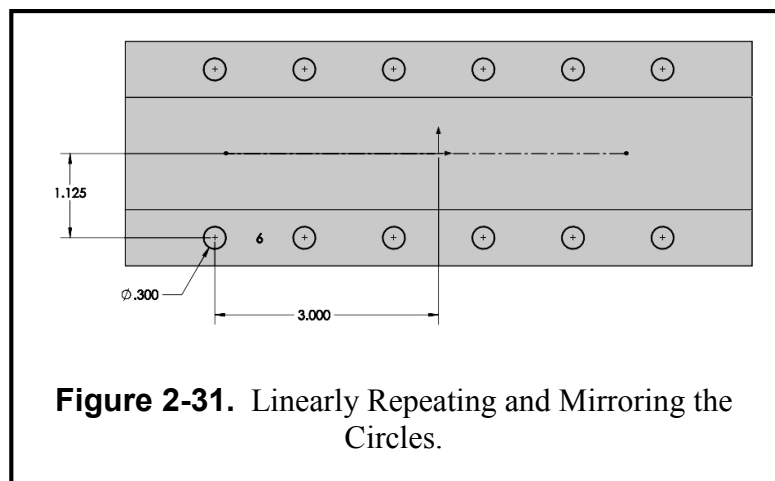
Draw a horizontal **Centerline** across the origin (Note the “—” symbol on your cursor means horizontal). Click the **Mirror** sketch icon and the mirror menu pops onto the screen. For the “Entities to Mirror,” select the six circles just created in the Linear pattern and in the “Mirror About” box select the centerline drawn through the origin. The selected items will get mirrored about the centerline, as shown in **Figure 2-31**.



**Figure 2-29.** The Extruded Base Part.

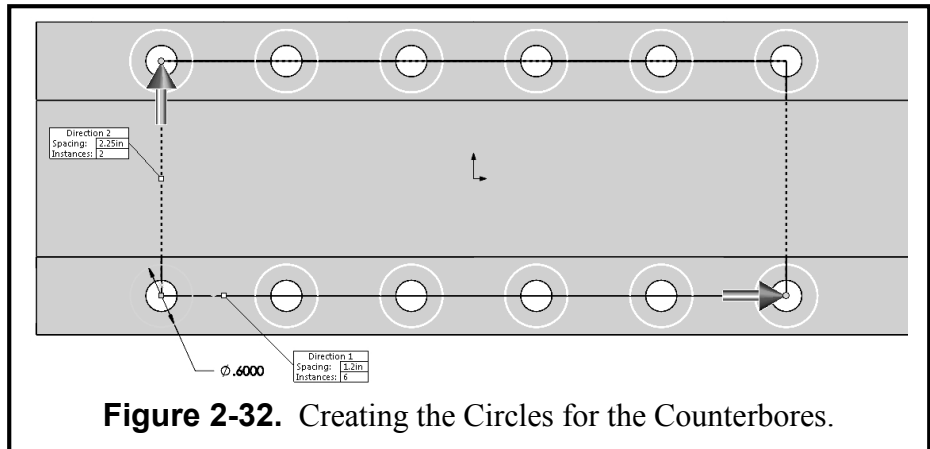


**Figure 2-30.** Drawing the First Circle.



**Figure 2-31.** Linearly Repeating and Mirroring the Circles.

Select the **Features** icon and select **Extruded Cut**. Use the **Through All** option and click the green (✓) check to close the menu. You have now drilled the small holes all the way through the plate's steps. You now need to bore some counterbore holes a quarter of the way down the small through holes. Note: This design feature is called a "Counterbore" and SOLIDWORKS has a special "Wizard" that can create it. However, we will leave that "Wizard" for a later lab.



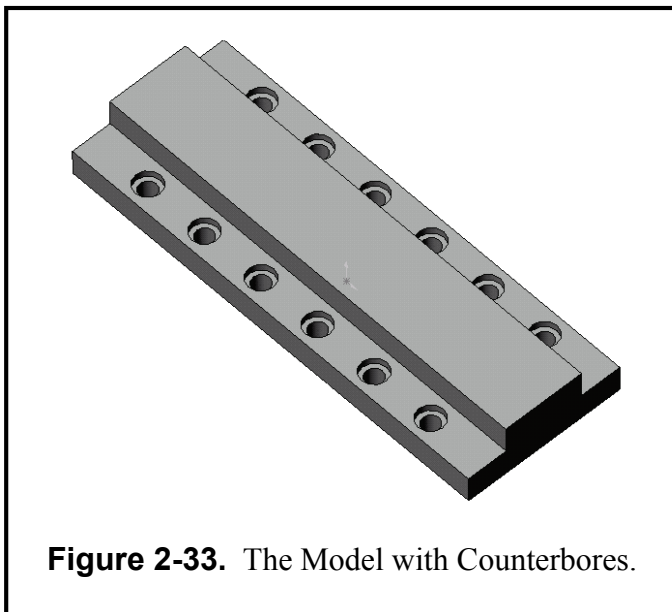
**Figure 2-32.** Creating the Circles for the Counterbores.

**Select** the top surface of the front step again. **Sketch** a **Circle** on that surface. Then add a relation to make the circle concentric with the hole beneath it (The diameter is **.60**). Now repeat the exact same process as before to get the twelve circles for the counterbore holes.

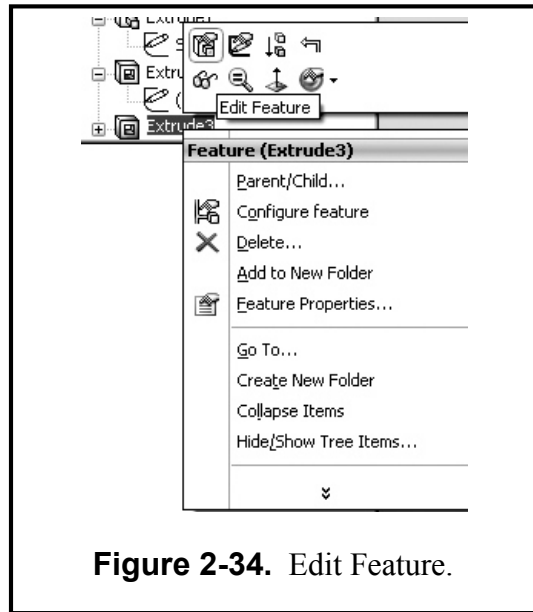
- **Select** the new circle
- Execute a **Linear Pattern** to get the front **6** circles at **1.20** inches apart in **Direction 1**.
- **In Direction 2** increase instances to **2** at a distance of **2.25** inches.

Select the **Features** icon and select **Extruded Cut**. Use the **Blind** option to a depth of **0.125** inches into the material. Click the green (✓) check to close the menu. You now bored the counterbores into the plate's two steps, as shown in **Figure 2-33** in a **Rotated View**.

Note: Sometimes you might make a mistake with a **FEATURE** operation like this one. You can simply right mouse click on its name in the Feature Manager and select the **Edit Feature** option on the menu. See **Figure 2-34**.

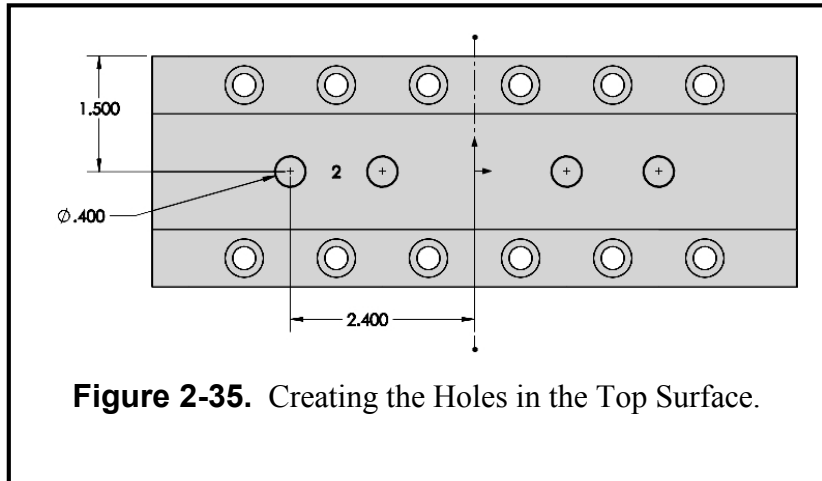


**Figure 2-33.** The Model with Counterbores.



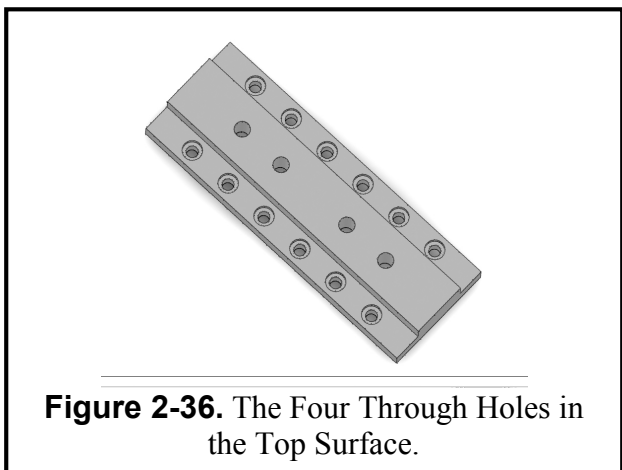
**Figure 2-34.** Edit Feature.

The next design requirement is to create four holes on the top of the plate. Pick a **Top** view and select the top surface to **Sketch** on. Draw a first **Circle** with the three **Dimension** values given in **Figure 2-35**. Use a **Linear Pattern** operation to get a second circle **1.2000** inches from the first circle. Draw a vertical **Centerline** through the origin (a | appears on the cursor). Then **Mirror** the two circles. This results in four circles as shown in **Figure 2-35**.

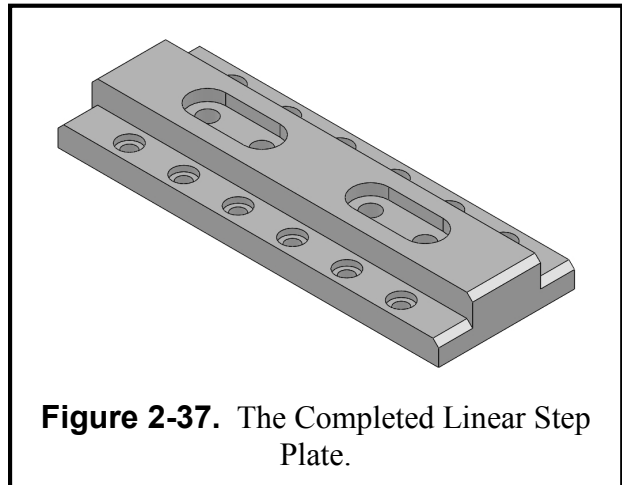


**Figure 2-35.** Creating the Holes in the Top Surface.

It is advisable to **go to an Isometric view** when executing an extrusion of any kind. Select the **Features** icon and select **Extruded Cut**. Use the **Through All** option and click the green (✓) check to close the menu. You now drilled the small holes all the way through the thick part of the plate. **Select the top surface** again to begin a new sketch. You will now add two counterbore slots. Select the **Slot** icon in the sketch menu. Select the **straight slot** type. Select the center of the left circle on the top plane and the one immediately to its right. This will make the slot concentric with the two circles to the left of the center. You can use an identical process to sketch the slot to the right of the center. Dimension the arcs of both slots to have a **Radius of .40**. Then **Cut Extrude** them to a **Blind** depth of **0.2500**. These counterbore slots are shown in **Figure 2-37**. To finish the step plate, chamfer the three horizontal edges on both ends of the model. Activate the **Features** tab and under the pull down menu of the **Fillet**, **Select Chamfer**. Set the chamfer value to **.125**, then select the three top horizontal edges of the ends of the step plate. Click the green (✓) check to complete the exercise.



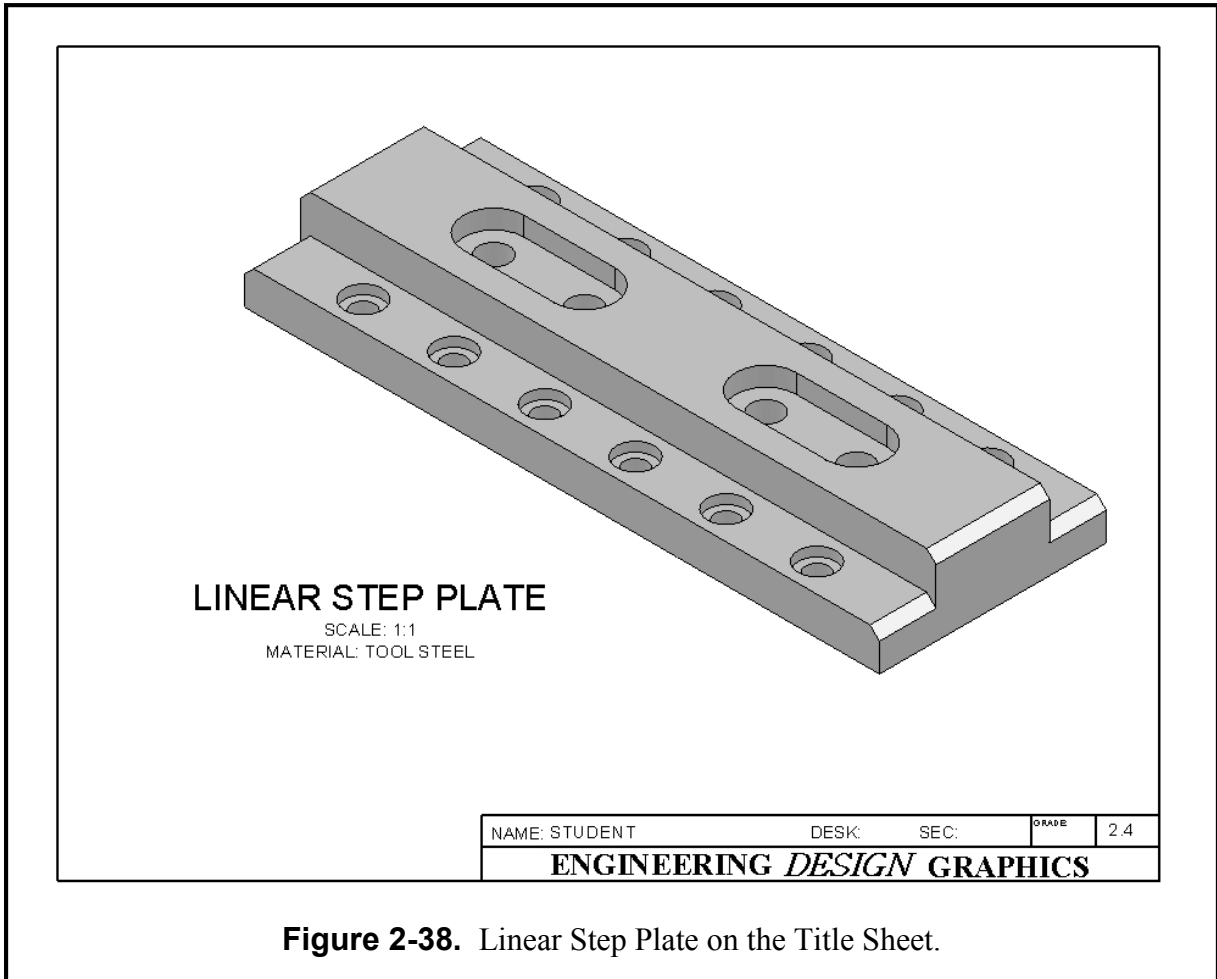
**Figure 2-36.** The Four Through Holes in the Top Surface.



**Figure 2-37.** The Completed Linear Step Plate.

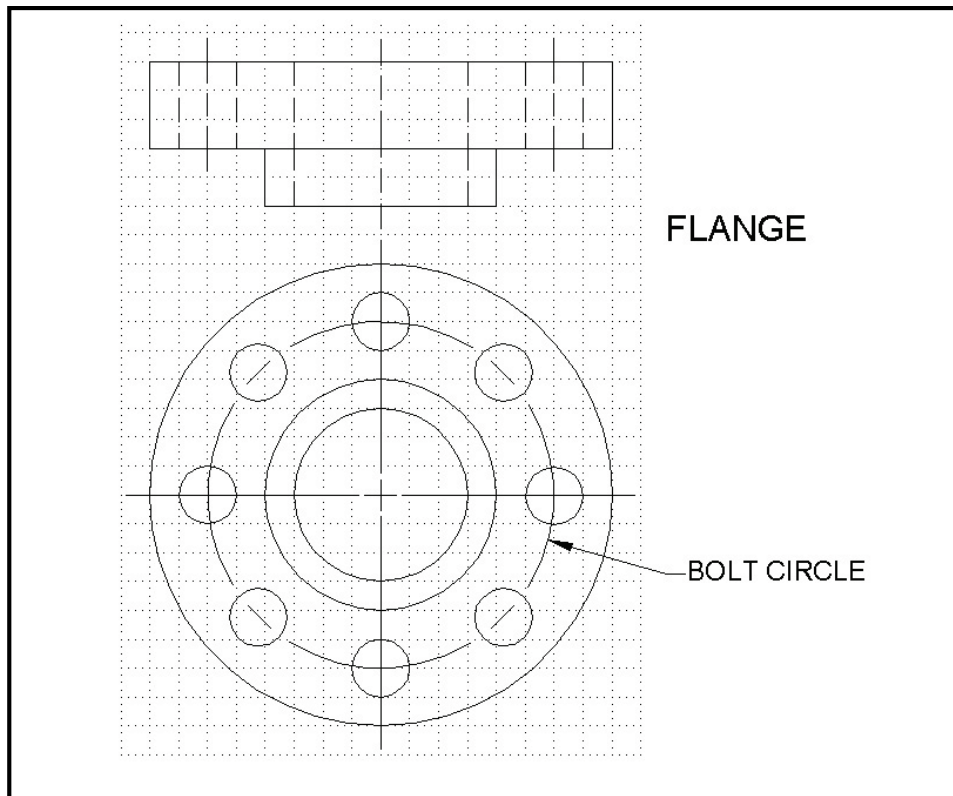
If you would like to change the color of your model, click on the model name in the Feature manager tree and then select the colored ball in the menu bar. You can then assign any color you wish to the model.

The part is now finished. Return to an **Isometric** view of the finished part as shown in **Figure 2-37**. Pull down **File**, select **Save As**, type in the part name **LINEAR STEP PLATE.sldprt**, and then click **Save**. Open your **TITLE BLOCK – INCHES.drwdot** and immediately **SAVE AS – LINEAR STEP PLATE.slddrw**. Now insert the rendered Linear Step Plate image onto your **Title Block** drawing sheet that was created in Chapter 1 and **Print** it on this sheet (see **Figure 2-38**).



## SUPPLEMENTARY EXERCISE 2-5: FLANGE

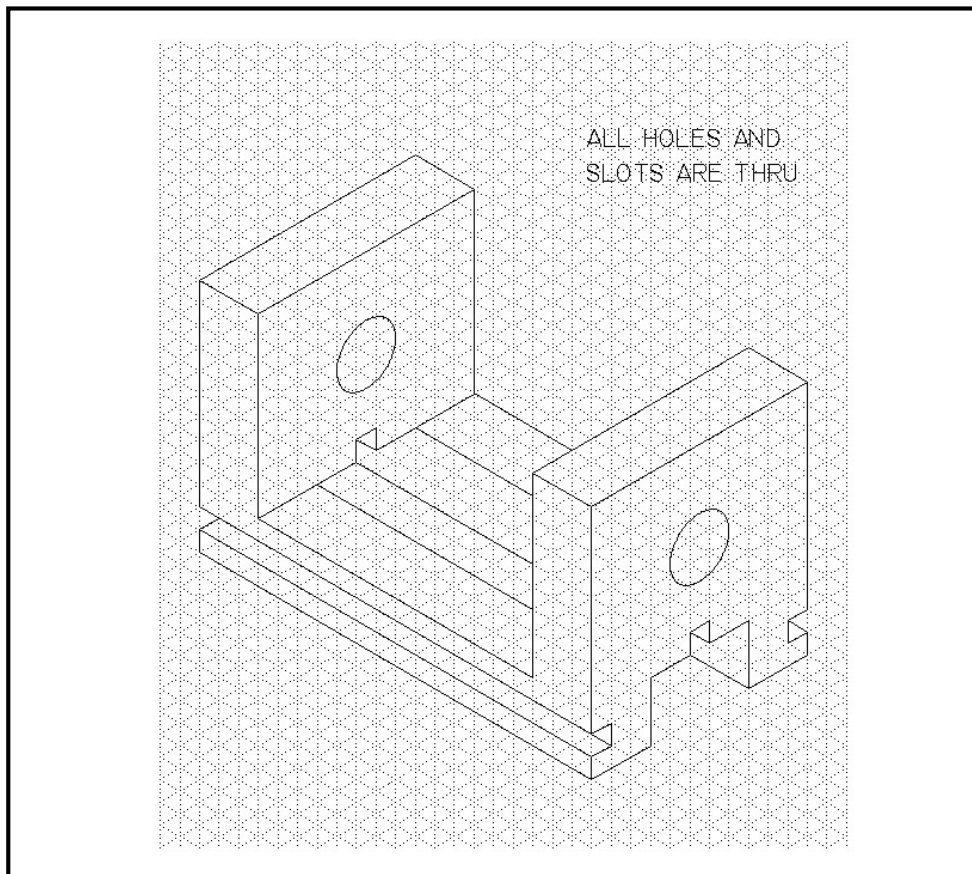
Using the **Revolve** command in the **Front Plane**, the **Circular Step and Repeat** commands learned in Unit 2, in the **Top Plane** Build the Flange and extrude it according to the grid divisions. Insert it on a Title Block and title it “**FLANGE.**”



**ASSUME THE GRID DIVISIONS TO BE 0.50 INCHES.**

## SUPPLEMENTARY EXERCISE 2-6: STEEL VISE BASE

Make a full size model of the figure below using the commands learned in Unit 2. Insert it onto a Title Block and title it **STEEL VISE BASE**.



**ASSUME THE GRID DIVISIONS TO BE 0.25 INCHES.**