

# Finite Element Simulations

with ANSYS® Workbench 17

Theory, Applications, Case Studies

Printed  
in Full Color

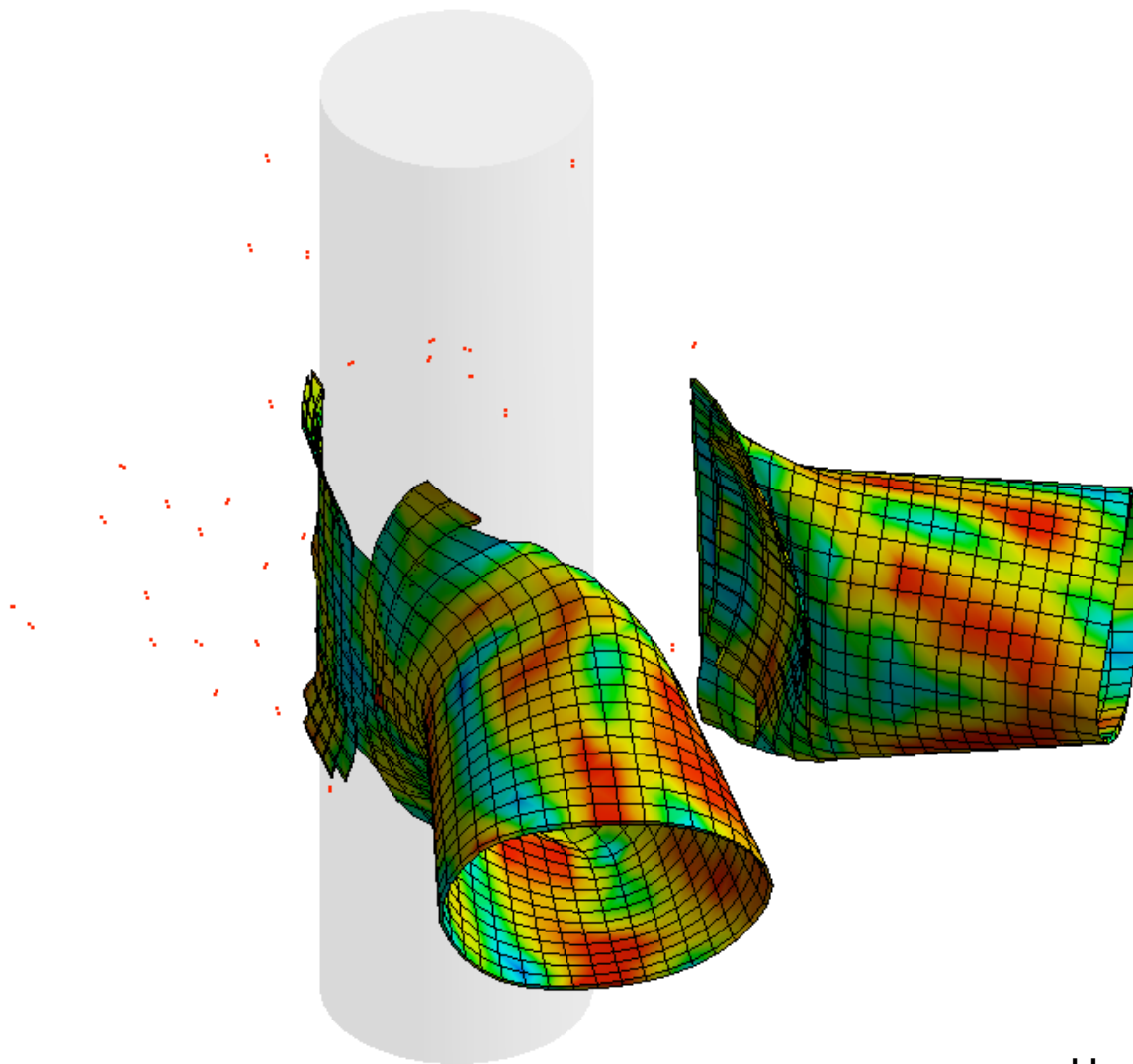

Huei-Huang Lee

Visit the following websites to learn more about this book:



[amazon.com](https://www.amazon.com)

[Google books](https://books.google.com)

[BARNES & NOBLE](https://www.barnesandnoble.com)

# Chapter 2

## Sketching

---

A complex 3D geometry can be viewed as a series of adding/removing material from simple solid bodies. Each solid body is often created by first drawing a 2D sketch, and then using the sketch to generate a 3D solid body with tools such as **Extrude**, **Revolve**, **Sweep**, **Skin/Loft**, etc.

### Purpose of This Chapter

This chapter provides exercises for the students so that they can be acquainted with sketching using **DesignModeler**. Profiles of several mechanical parts are sketched in this chapter. Each sketch is then used to generate a 3D model using either **Extrude** or **Revolve**. The use of these 3D tools is so trivial that we may focus on 2D sketching techniques.

### About Each Section

Each mechanical part will be completed in a section. Section 2.1 sketches a cross section of W16x50; the cross section is then extruded to generate a 3D beam. Section 2.2 sketches a triangular plate; the sketch is then extruded to generate a 3D solid model. Section 2.3 does not provide a hands-on case. Rather, it overviews the sketching tools in a systematic way, attempting to complement what was missed in the first two sections. Sections 2.4, 2.5, and 2.6 provide three additional exercises, in which we'll purposely leave out some steps for the students to figure out the details.

# Section 2.1

## W16x50 Beam

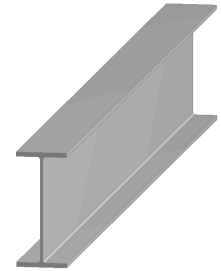

### 2.1-1 About the W16x50 Beam

In this section, we will create a W16x50 [1-4] steel beam. The beam has a length of 10 ft.

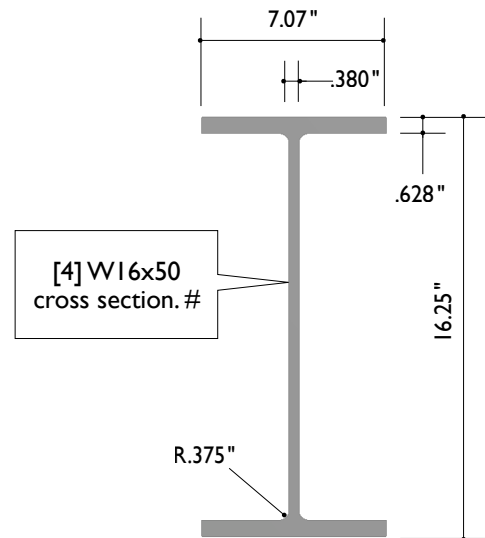
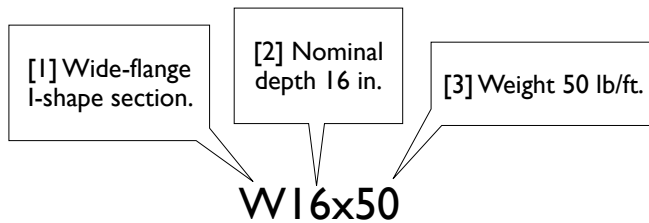

### 2.1-2 Start Up DesignModeler

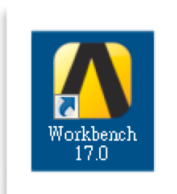

[1] Double click to launch **Workbench**.

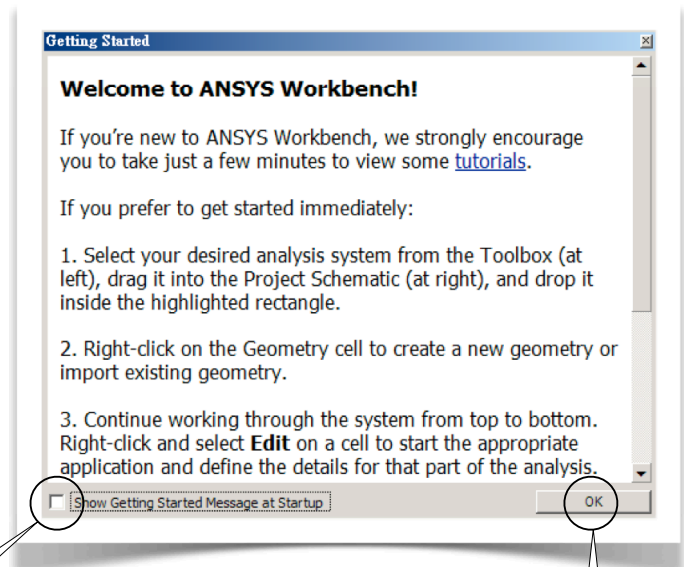

[2] If a **Getting Started** message window appears, uncheck this box so that it won't appear next time at startup.

[3] Click **OK** to dismiss this window.



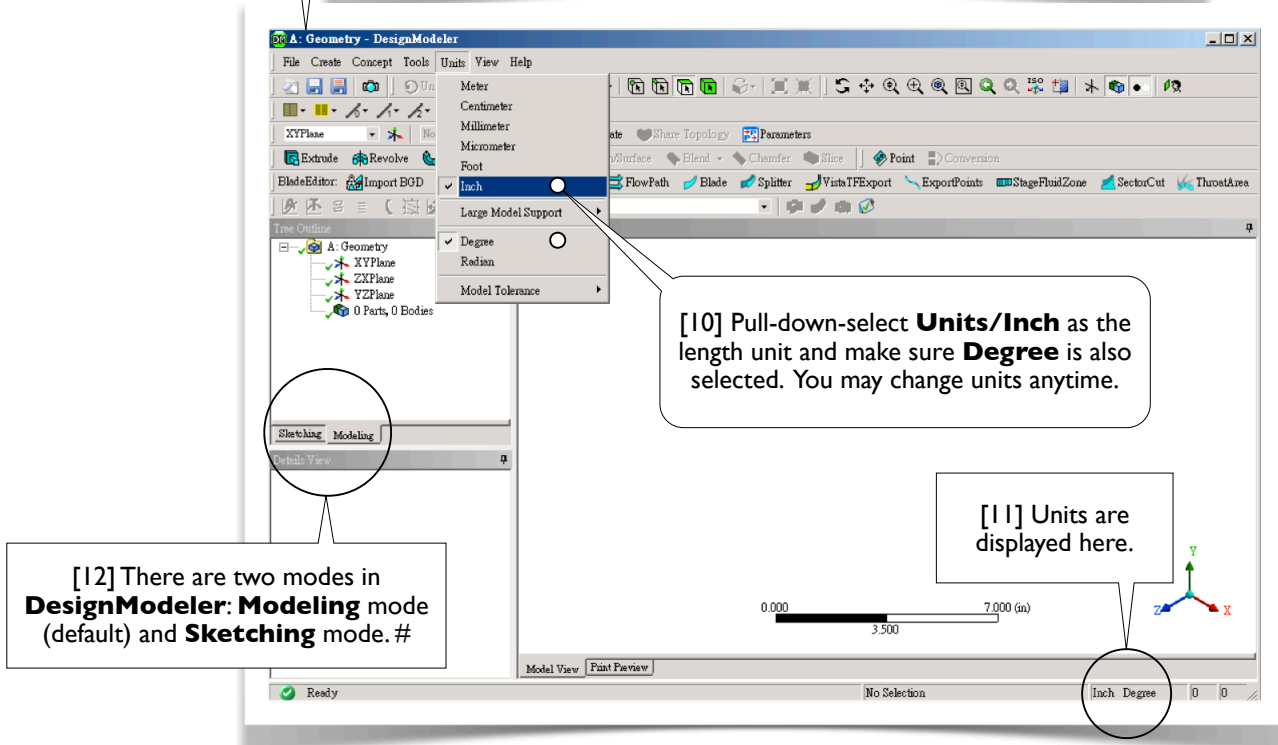
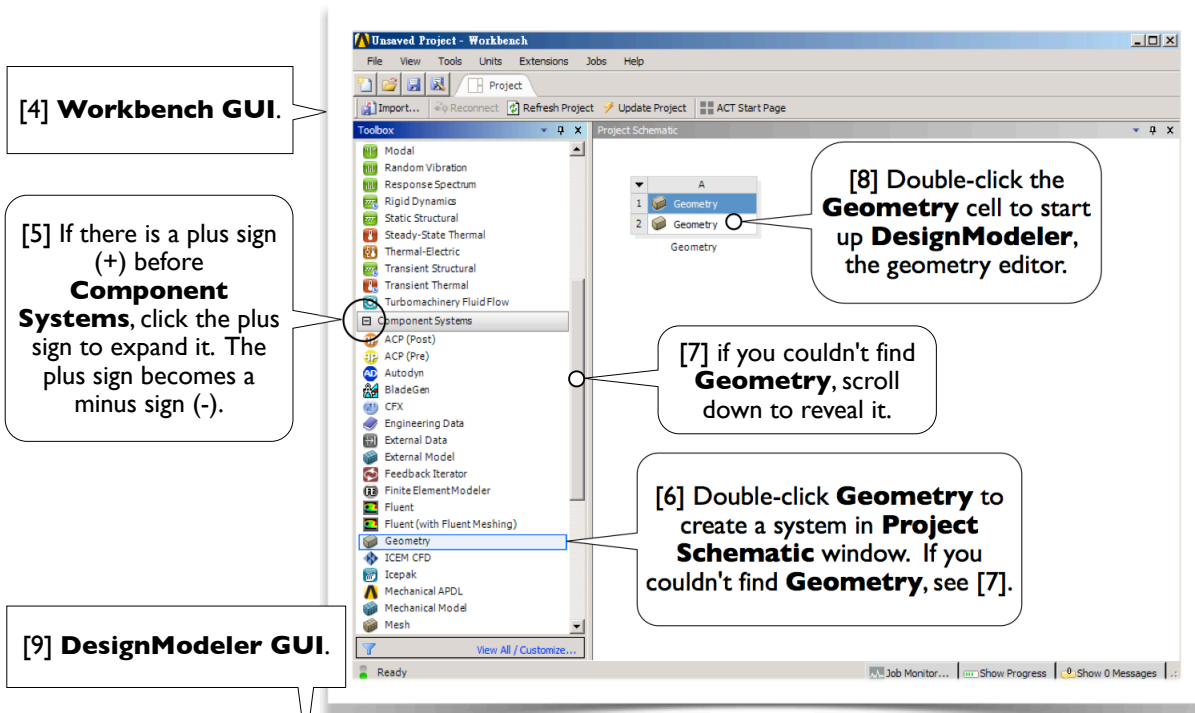

**About Textboxes**

In this book, a round-cornered textbox (e.g., [1-3, 5-8, 10]) is used to indicate that mouse or keyboard ACTIONS are needed in that step. A sharp-cornered textbox (e.g., [4, 9, 11-12]) is used for commentary only; no mouse or keyboard actions are needed in that step.

## 2.1-3 Draw a Rectangle on **XYPlane**

[1] Current **sketching plane** is displayed here. **XYPlane** is the default sketching plane.

[2] Click the **Sketching mode**.

[3] This is the **global coordinates system**. **Workbench** uses red, green, and blue (RGB) arrows to indicate X, Y, and Z directions, respectively.

[4] Click **Look At** so that you look at the sketching plane, **XYPlane**.

[5] Click the **Rectangle tool**.

[6] Draw a rectangle roughly like this by clicking a corner and then dragging to the diagonally opposite corner

[7] As soon as you begin to draw, a sketch (with default name **Sketch1**) is created on the sketching plane.

**Details of Sketch1**

Sketch	Sketch1
Sketch Visibility	Show Sketch
Show Constraints?	No
<b>Edges: 4</b>	
Line	Ln7
Line	Ln8
Line	Ln9
Line	Ln10

[8] Click the **Constraints** toolbox. We want to impose symmetry constraints.

[9] If the **Symmetry** tool is not visible, click to scroll down until you see the tool.

[10] Click the **Symmetry** tool.

[11] Click the vertical axis and then the two vertical lines to make the lines symmetric about the vertical axis.

[12] Right-click anywhere on the graphic window to open a context menu, and choose **Select new symmetry axis**.

[13] Click the horizontal axis and then the two horizontal lines to make the lines symmetric about the horizontal axis.

The image shows a CAD interface with a sketch of a vertical beam section. A context menu is open, highlighting 'Select new symmetry axis'. The sketching toolbox on the left has 'Symmetry' selected. The sketch shows two vertical lines and two horizontal lines, with a vertical dashed line as the symmetry axis. Dimensions of 0.000, 3.900, and 7.000 (in) are visible at the bottom.

[14] Click the **Dimensions** toolbox.

[15] **General** is the default tool.

[16] Click this line, move the mouse upward, and click to create H1.

[17] Click this line, move the mouse rightward, and click again to create V2.

[18] All the lines turn to blue color. Colors are used to indicate **constraint status**. The blue color means the geometric entities are well-defined (fixed in the space).

[19] In **Details View**, type 7.07 (in) for H1 and 16.25 (in) for V2.

[20] Click **Zoom to Fit**.

The image shows the same CAD interface with the 'Dimensions' toolbox selected. Two dimension lines are shown: a horizontal one labeled 'H1' and a vertical one labeled 'V2'. The sketching toolbox now shows 'General' as the active tool. The sketching area shows the beam section with dimension lines and a vertical dashed line. Dimensions of 0.000, 5.000, and 10.000 (in) are visible at the bottom.

## 2.1-4 Set Up Sketching Options

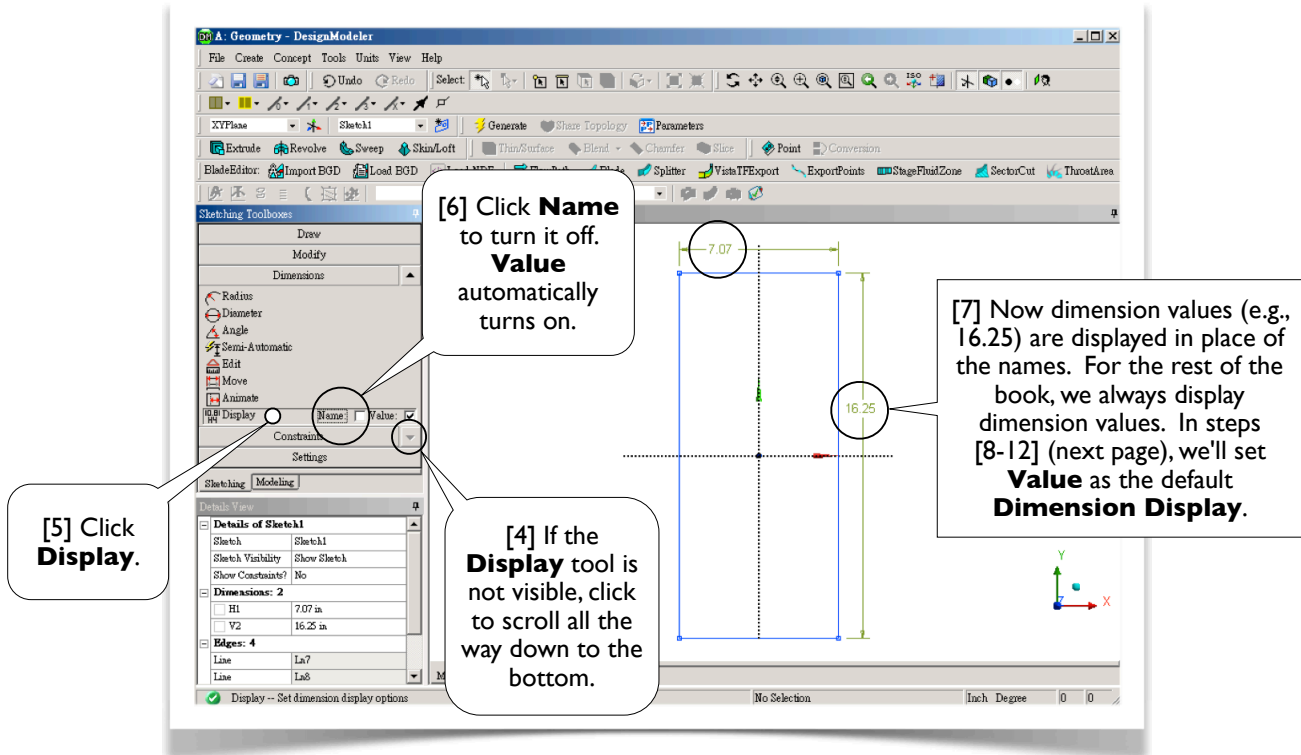
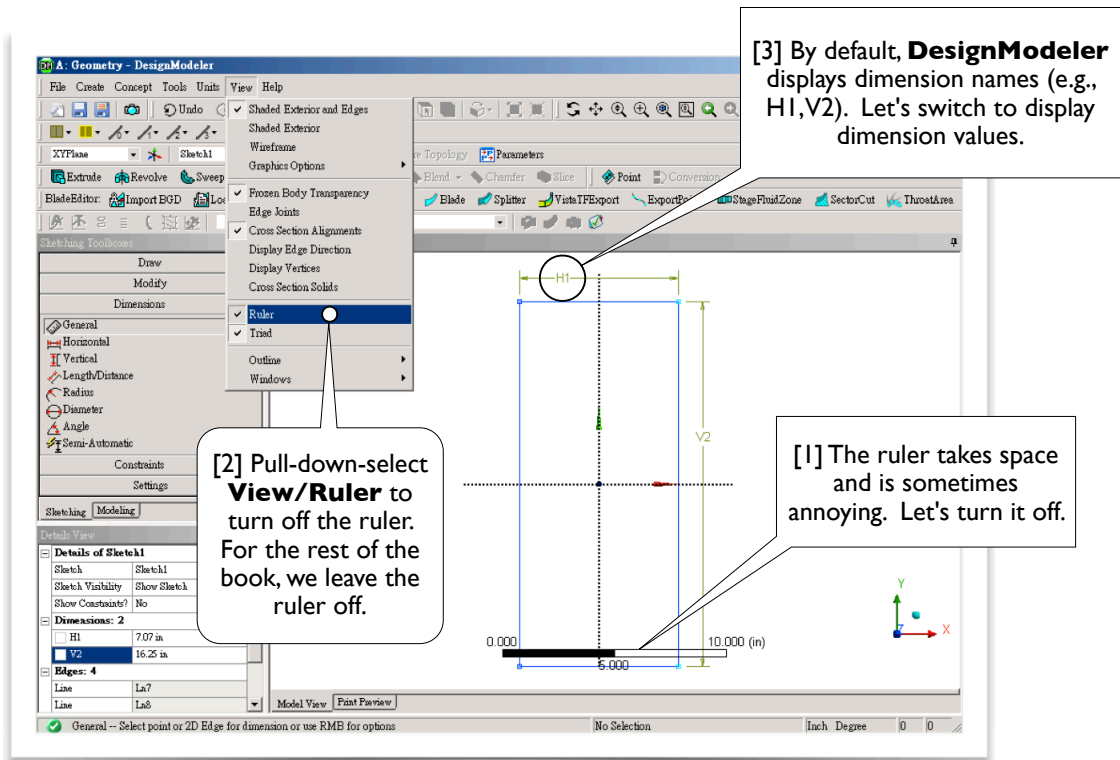

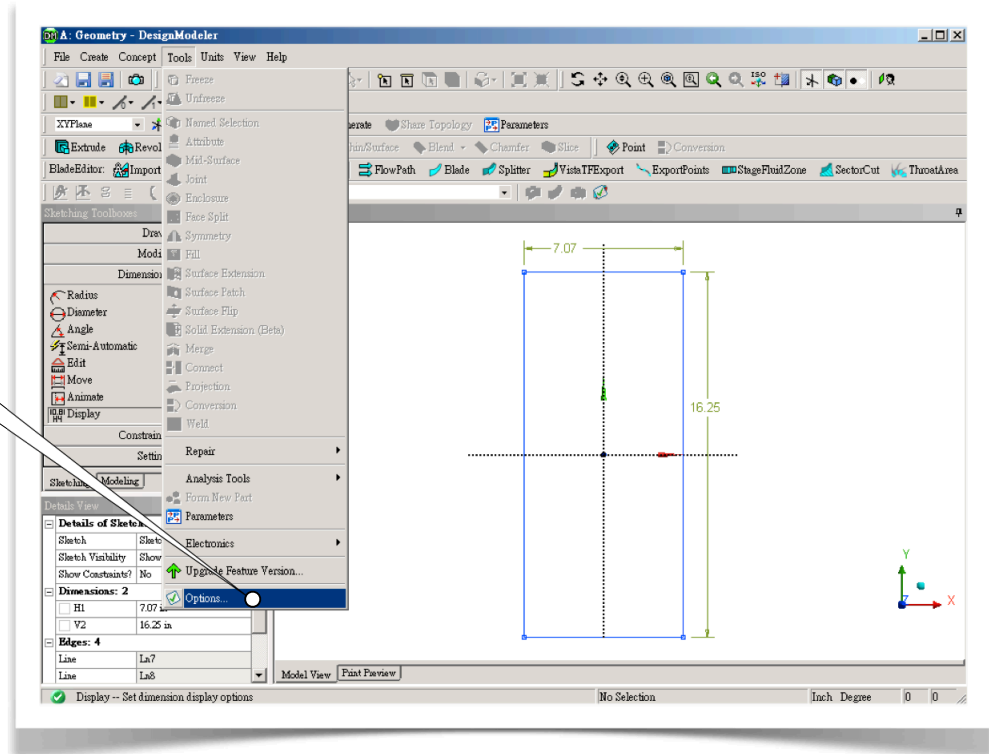

[8] Pull-down-select **Tools/Options...**

[9] Select **Sketching**.

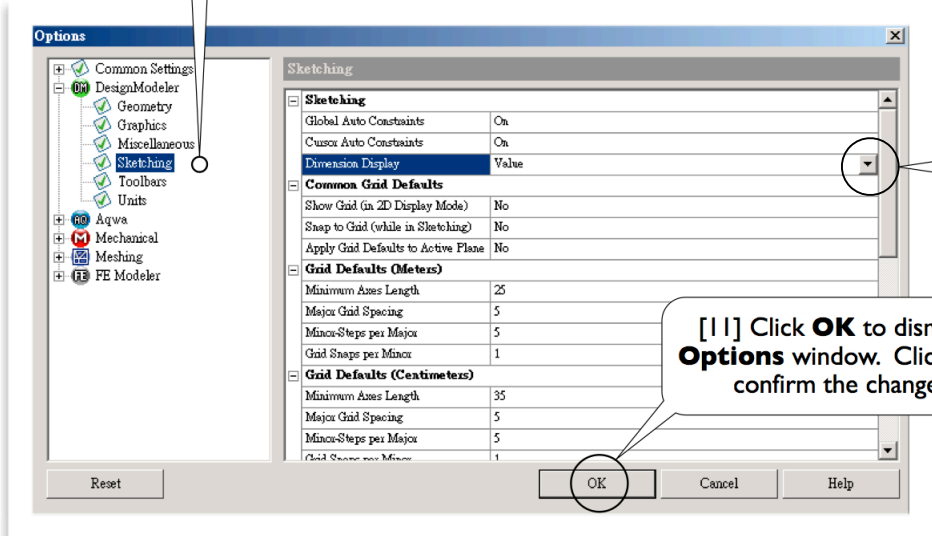

[10] Select **Value** as the default **Dimension Display**.

[11] Click **OK** to dismiss the **Options** window. Click **Yes** to confirm the changes. #

### Background Color of the Graphic Area

In this book, for better readability, the background color of the graphic area is always shown in white. If your background color is not white and you want to change it to white, pull-down-select **Tools/Options** in **Workbench GUI** (not **DesignModeler GUI**; see 2.1-2[4], page 57) and click **Appearance**.

## 2.1-5 Draw a Polyline

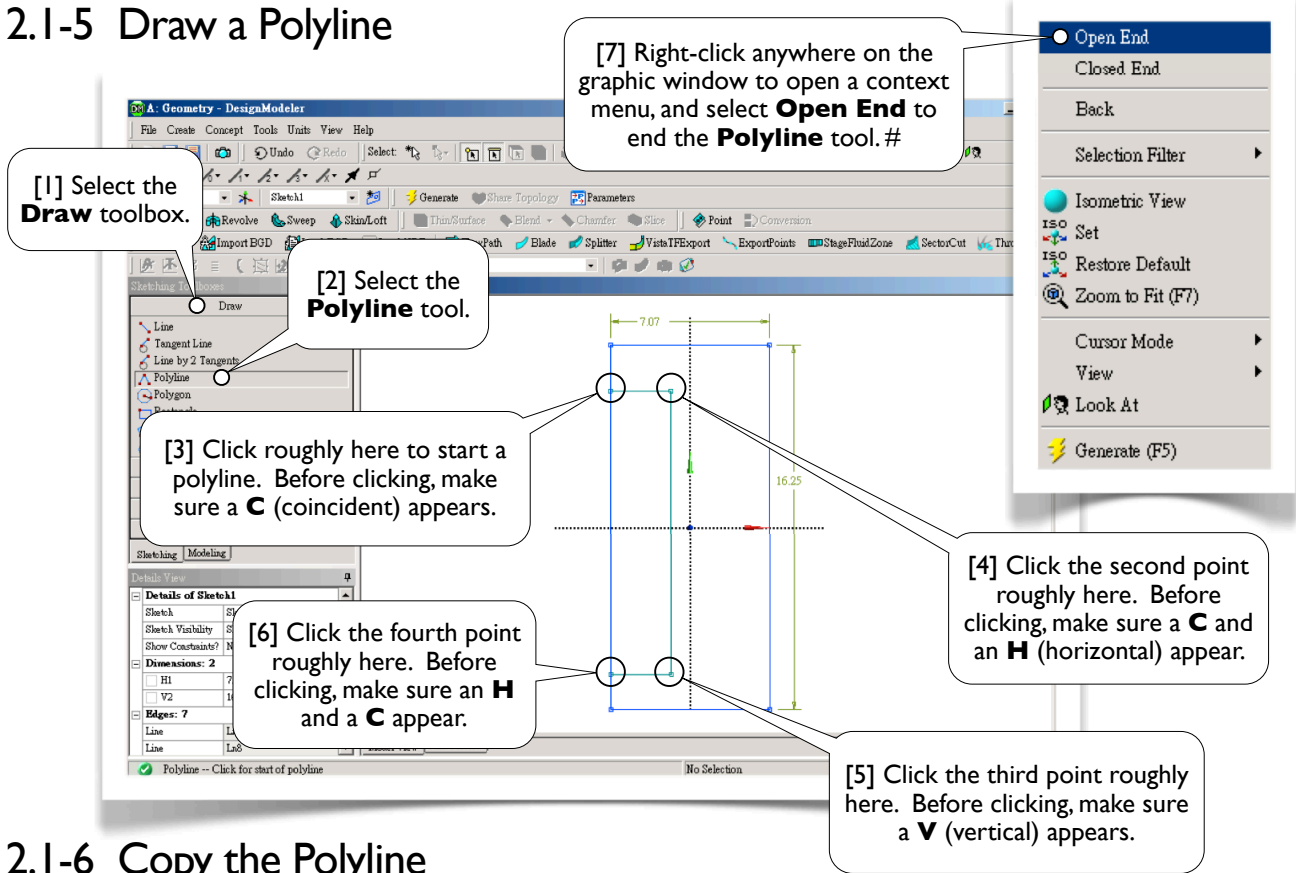

## 2.1-6 Copy the Polyline

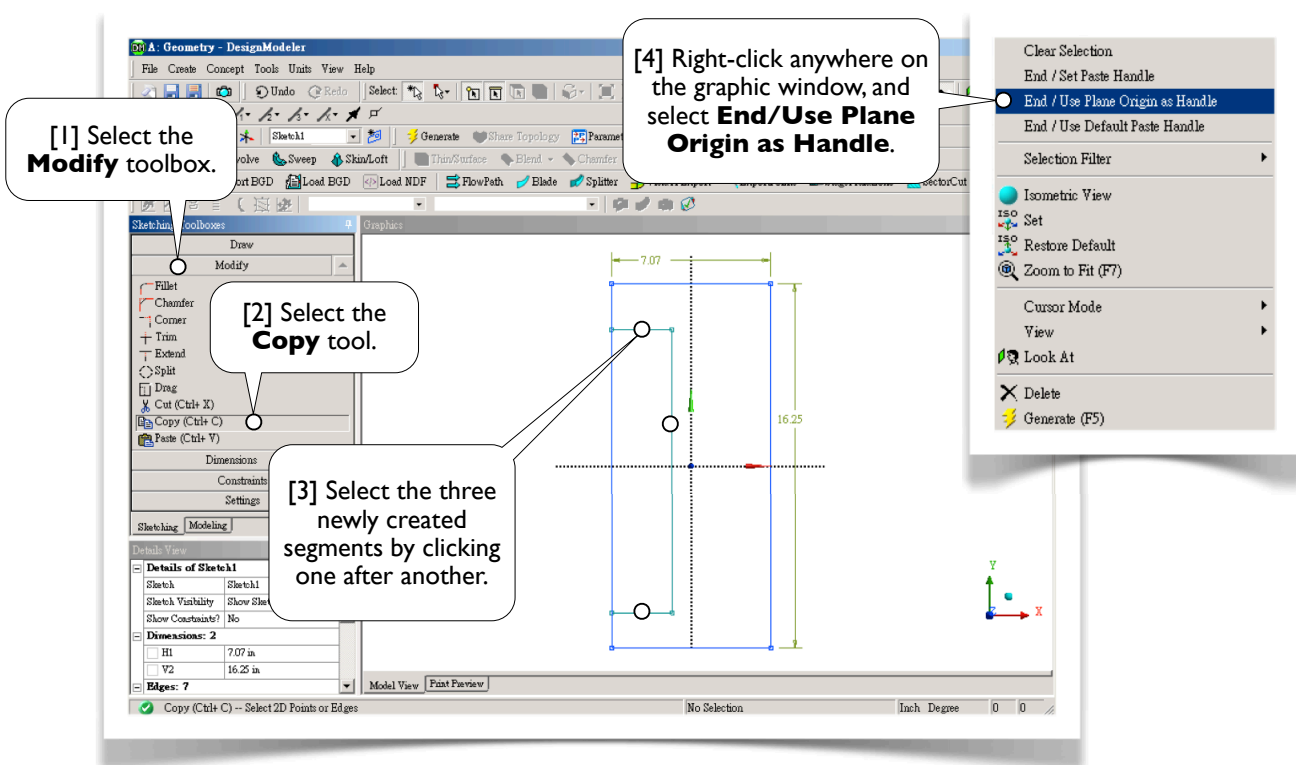

[5] The **Paste** tool is automatically selected.

[6] Right-click-select **Flip Horizontal**.

[7] Right-click-select **Paste at Plane Origin**.

[8] Right-click-select **End** to end the **Paste** tool. An alternative way (a more convenient way) is to press **ESC** to end a tool. #

## 2.1-7 Basic Mouse Operations in Sketching Mode

Now, try these basic mouse operations in sketching mode [1-6]. Press **ESC** to deselect all entities. After trying any of [4-6], click **Zoom to Fit** (2.1-3[20], page 59) or **Look At** (2.1-3[4], page 58) to go back to the fitting view.

[1] **Click**: add a sketching entity to the selection set. Click a selected entity to remove it from the selection set.

[6] **Middle-click-drag**: rotate.  
**Shift-middle-click-drag**: zoom.  
**Control-middle-click-drag**: pan. #

[5] **Scroll-wheel**: zoom in/out.

[4] **Right-click-drag**: box zoom.

[2] **Click-Sweep**: continuous selection.

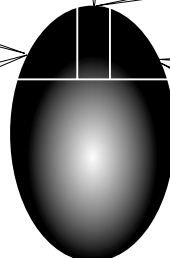

[3] **Right-click**: open a context menu.



## 2.1-8 Trim Away Unwanted Segments

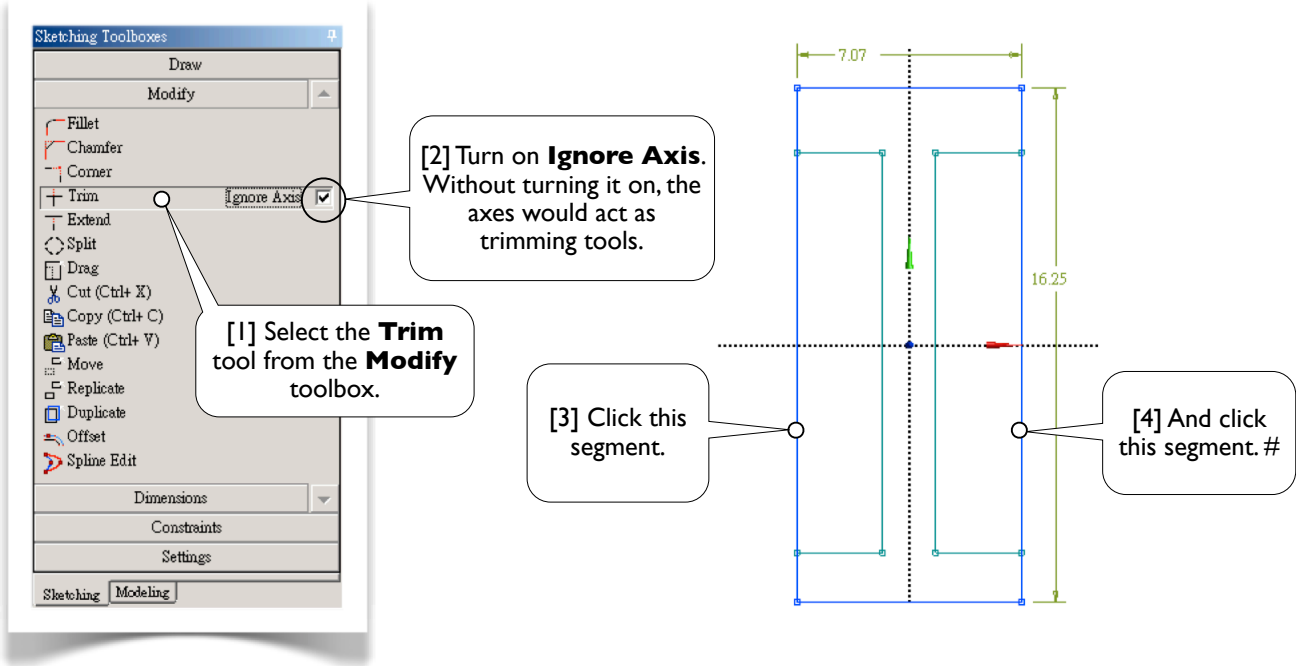

## 2.1-9 Impose Symmetry Constraints

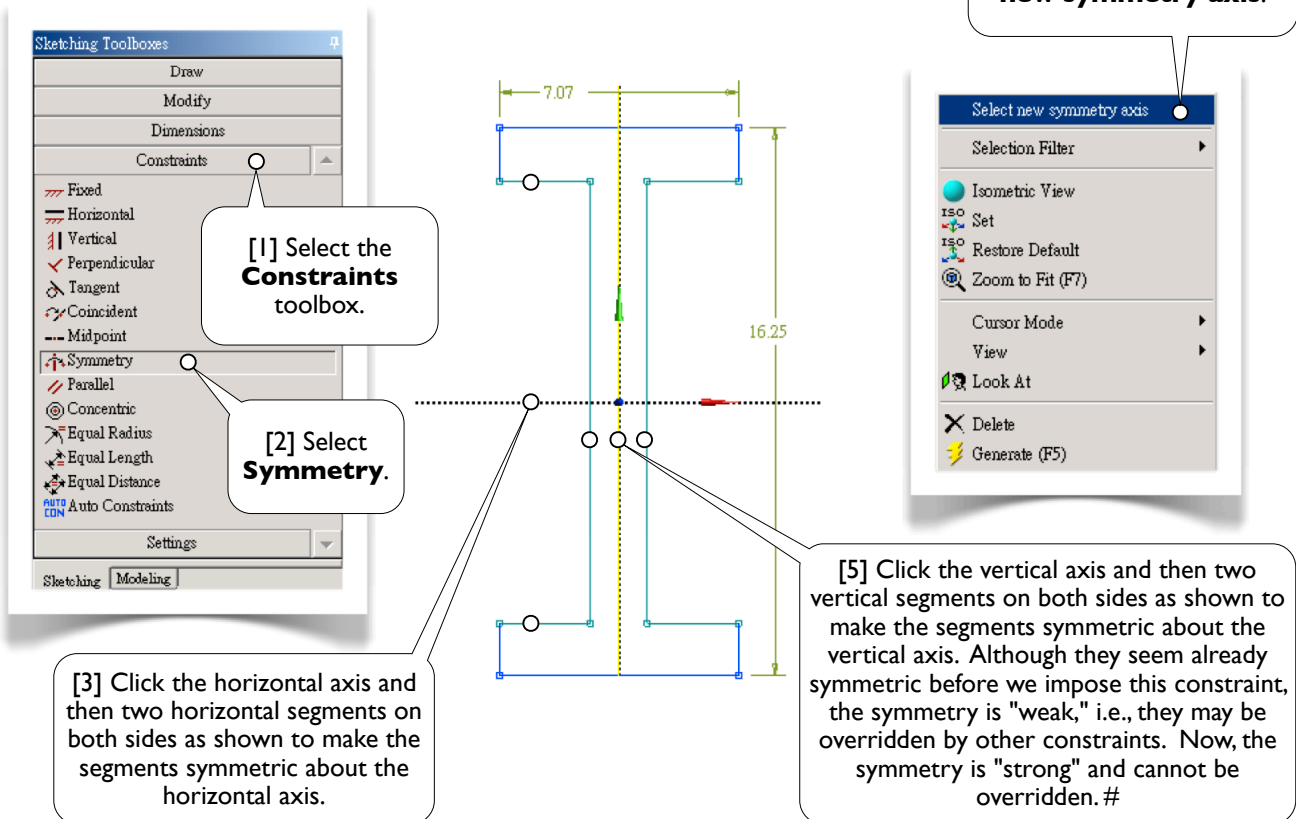



## 2.1-10 Specify Dimensions

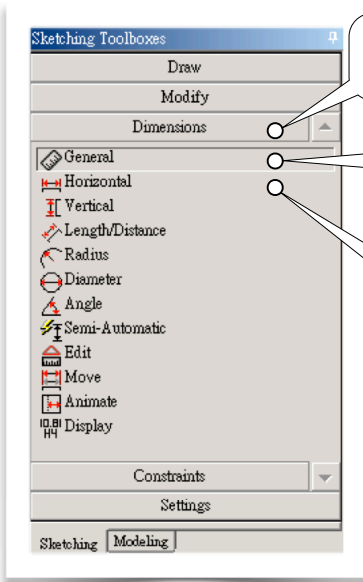

[1] Select the **Dimensions** toolbox.

[2] **General** is the default tool.

[5] Select **Horizontal**.

[3] Click this vertical segment and move leftward to create a dimension (in details view [4], the name is V3).

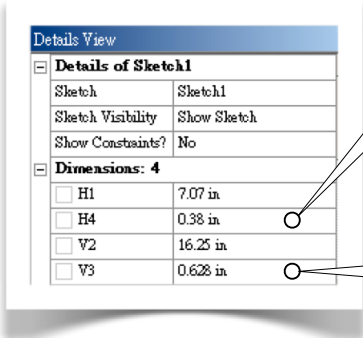

[7] In **Details View**, type 0.38 (in) for H4.

[4] In **Details View**, type 0.628 (in) for V3.

[6] Click these two vertical segments one after the other and move upward to create a horizontal dimension (H4).

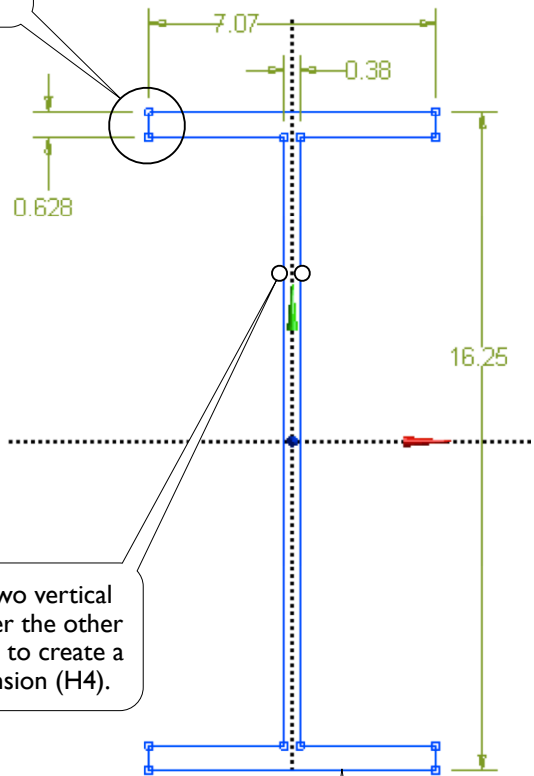

[8] All the sketching entities are blue-colored, meaning that they are well-defined (fixed in the space). #

## 2.1-11 Add Fillets

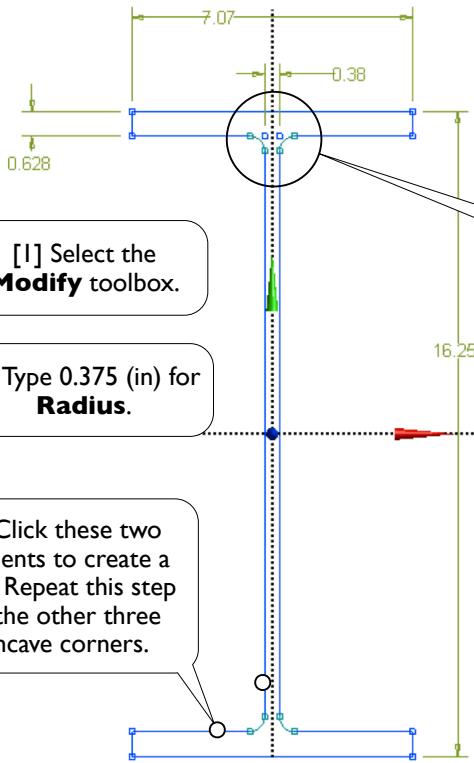
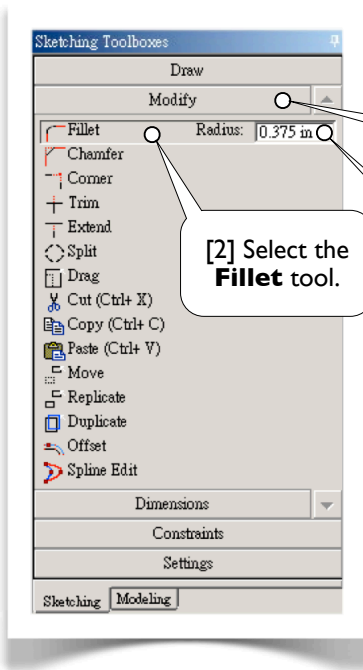

- [1] Select the **Modify** toolbox.
- [2] Select the **Fillet** tool.
- [3] Type 0.375 (in) for **Radius**.
- [4] Click these two segments to create a fillet. Repeat this step for the other three concave corners.
- [5] The greenish-blue color of the fillets indicates that these fillets are under-constrained. The radius specified in [3] is a "weak" dimension (may be overridden by other constraints). We could specify a **Radius** dimension (in the **Dimensions** toolbox) to turn the fillets blue. However, we decide to ignore the color. We want to demonstrate that an under-constrained sketch can still be used. Remember, however, it is a good practice to make all entities blue-colored. #

## 2.1-12 Move Dimensions

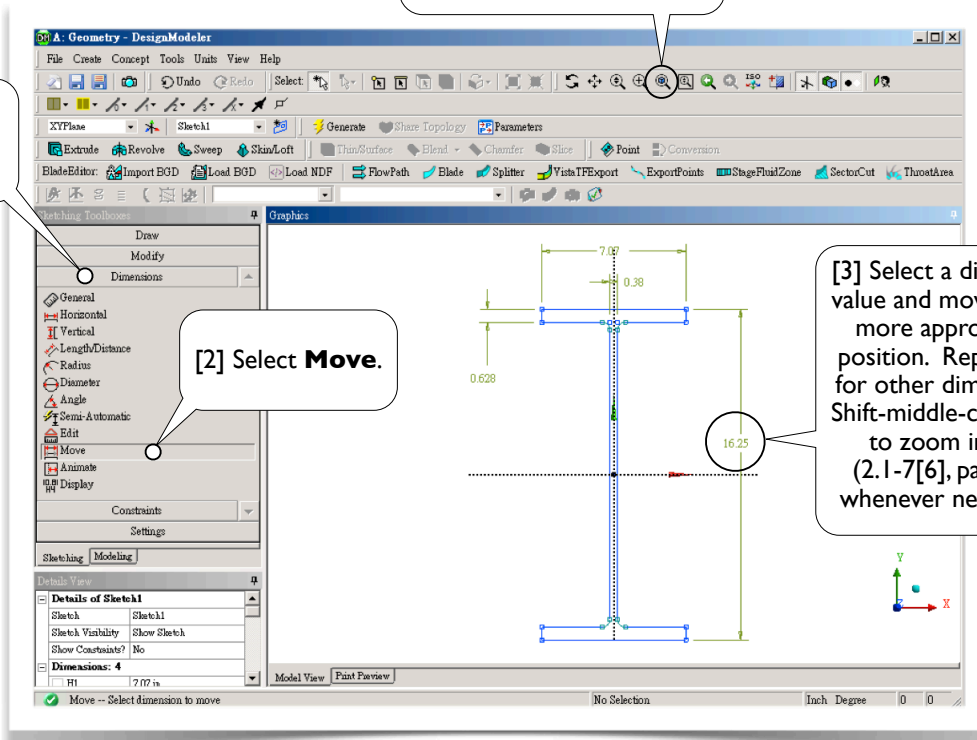

- [1] Select the **Dimensions** toolbox.
- [2] Select **Move**.
- [3] Select a dimension value and move it to a more appropriate position. Repeat this for other dimensions. Shift-middle-click-drag to zoom in/out (2.1-7[6], page 63) whenever necessary.
- [4] Click **Zoom to Fit**. #

## 2.1-13 Generate a 3D Solid Body

[3] Remember that the active sketch is shown here (2.1-3[7], page 58).

[4] Click **Extrude**.

[5] It automatically switches to the **Modeling** mode.

[6] Click **Apply**. By default, the active sketch (see [3]) is selected as **Geometry**.

[7] Type 120 (in) for **Depth**.

[8] Click **Generate**.

[1] Click the little cyan sphere to rotate the view to an isometric view, which is a convenient 3D view.

[2] The view rotates to an isometric view.

[9] Click **Display Plane** to turn off the display of sketching plane.

[10] Click **Zoom to Fit**. Feel free to use this tool any time.

[11] Click all plus signs (+) to expand the **model tree** and browse its structure. #

## 2.1-14 Save Project and Exit Workbench

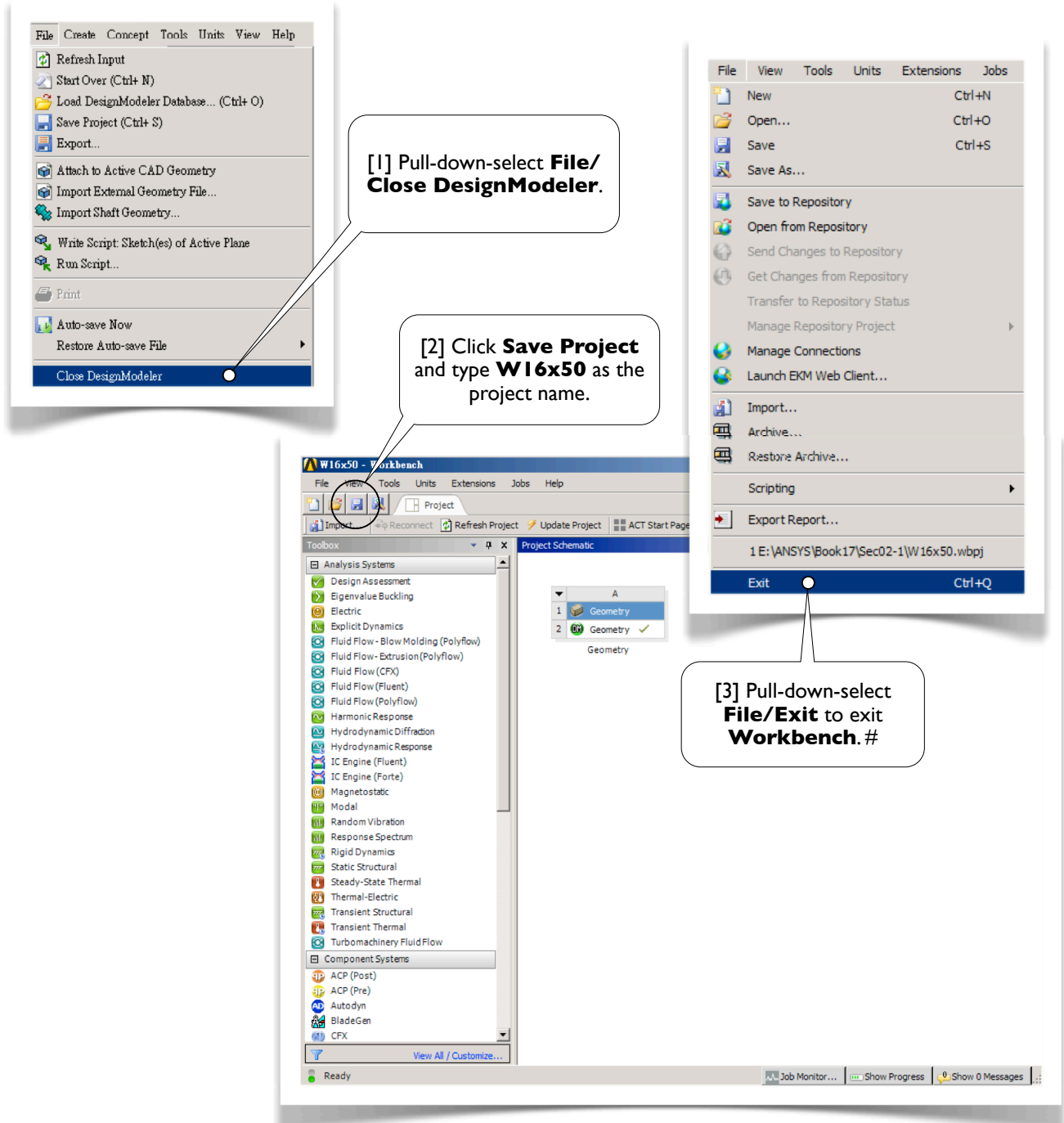

### Supporting Files

To download the finished project files or view the demo videos, please visit the SDC Publications website. See the inside front cover for details.

# Section 2.2

## Triangular Plate



### 2.2-1 About the Triangular Plate

The triangular plate [1, 2], with a thickness of 10 mm, is made to withstand tensile forces on three side faces [3].

In this section, we'll sketch a profile of the plate on **XYPlane** and then extrude a thickness of 10 mm along Z-axis to generate a 3D solid body.

In Section 3.1, we will use this sketch again to generate a 2D solid model, which is then used for a static structural simulation to assess the stress under design loads.

The 2D solid model will be used again in Section 8.2 to demonstrate a design optimization procedure.

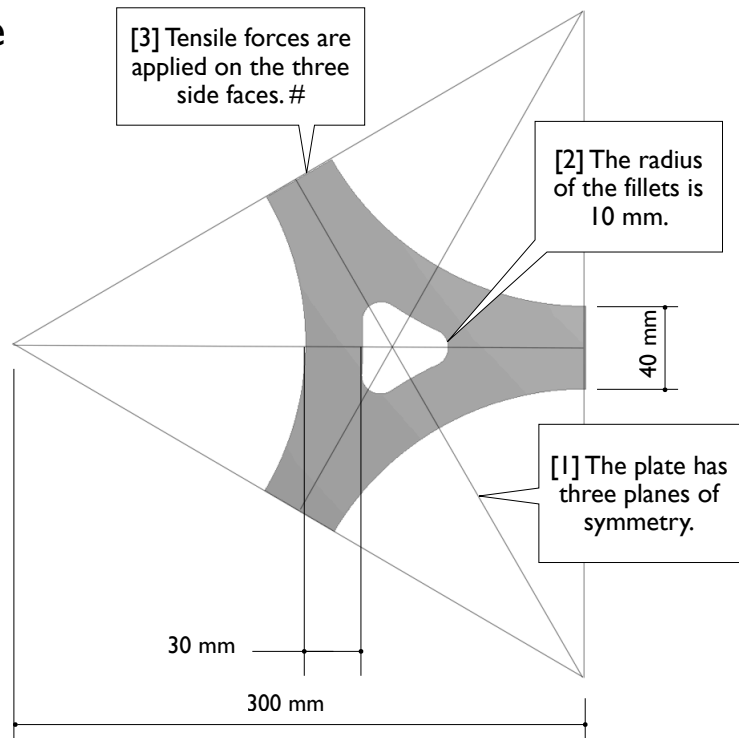

### 2.2-2 Start up DesignModeler

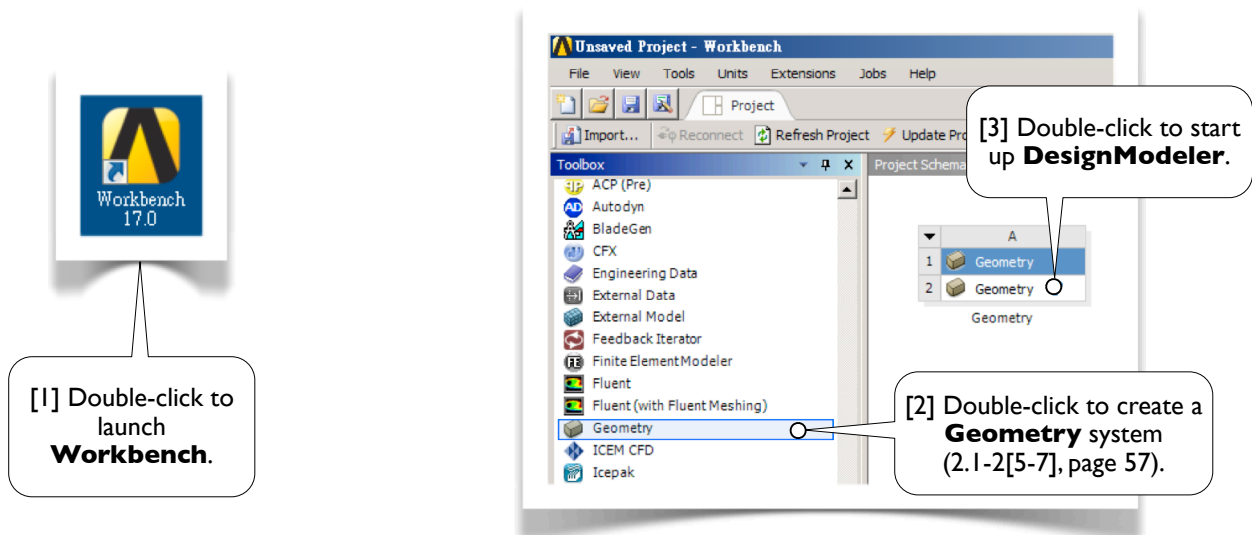

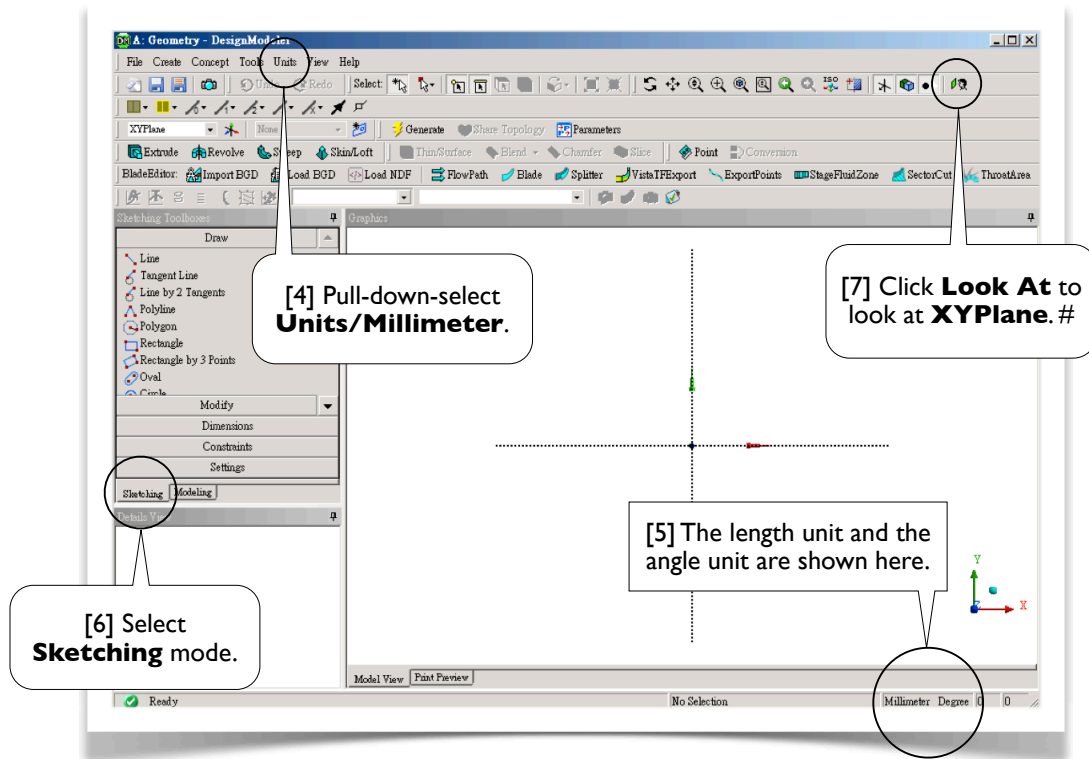

### 2.2-3 Draw a Triangle on XYPlane

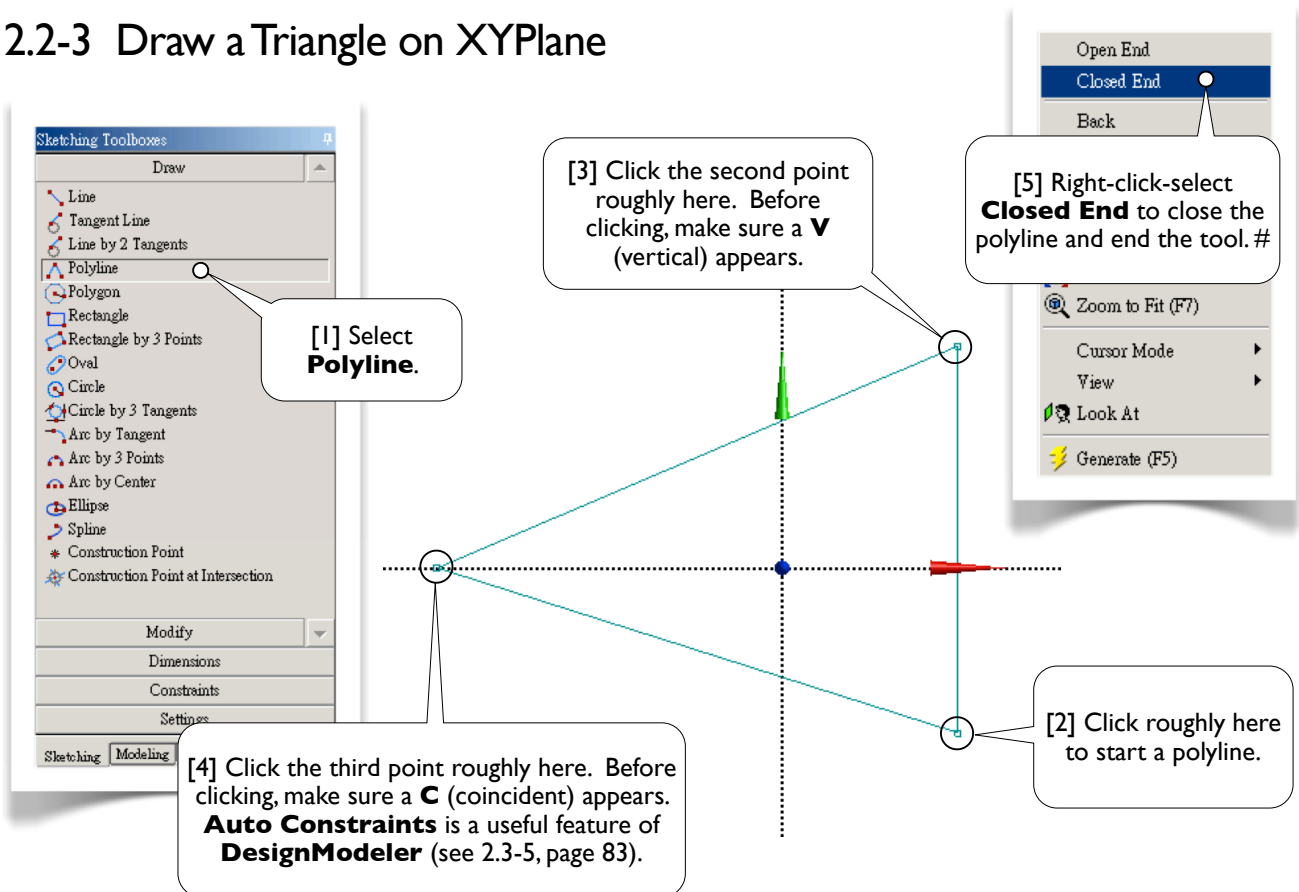

## 2.2-4 Make the Triangle Regular

[1] From the **Constraints** toolbox, select the **Equal Length** tool.

[2] Click this and the vertical segments to make their lengths equal.

[3] Click this and the vertical segments to make their lengths equal. #

## 2.2-5 2D Graphics Controls

Tools for 2D graphics controls are available in the **Display Toolbar** [1-9]. Click the tools in [3-5] to switch them on/off. Feel free to use these tools any time. Try to click each tool now. They don't modify the model. Note that other ways to **Pan**, **Zoom**, and **Box Zoom** are given in 2.1-7 (page 63) and 2.3-4 (page 82).

[3] When on, **Pan** allows you to click-and-drag on the graphic area to move the sketch.

[2] **Zoom to Fit** fits the entire sketch in the graphic area.

[7] Click **Next View** to go to next view.

[1] **Look At** rotates the view so that you look at the sketch.

[5] When on, **Zoom** allows you to click-and-drag on the graphic area to zoom in/out.

[4] When on, **Box Zoom** allows you to click-and-drag a box on the graphic area to enlarge that portion of the graphics.

[6] Click **Previous View** to go to previous view.

[8] Click **Undo** to undo what you've just done. Multiple undo is allowed. This tool is available only in **Sketching** mode.

[9] Click **Redo** to redo what you've just undone. This tool is available only in **Sketching** mode. #

## 2.2-6 Specify Dimensions

[1] From the **Dimension** toolbox, select **Horizontal**.

[2] Click the vertex on the left (before clicking, make sure that the cursor turns to a point) and the vertical line on the right, and then move the mouse downward to create this dimension. (The value 300 is typed in step [4].)

[3] Click the vertex on the left and the vertical axis, and then move the mouse downward to create this dimension. All the segments turn blue, indicating they are well defined now. (The value 200 is typed in step [4].)

[4] In **Details View**, type 300 (mm) and 200 (mm) for the dimensions just created. Click **Zoom to Fit** (2.2-5[2], last page).

[5] Select **Move** and move the dimensions to appropriate positions (2.1-12[2-3], page 66). #

Details of Sketch1	
Sketch	Sketch1
Sketch Visibility	Show Sketch
Show Constraints?	No
<b>Dimensions: 2</b>	
<input type="checkbox"/> H1	300 mm
<input type="checkbox"/> H2	200 mm

## 2.2-7 Draw an Arc

[1] From the **Draw** toolbox, select **Arc by Center**.

[2] Click this vertex as the arc center. Before clicking, make sure a **P** (point) constraint appears.

[3] Click the second point roughly here. Before clicking, make sure a **C** (coincident) constraint appears.

[4] Click the third point here. Before clicking, make sure a **C** (coincident) constraint appears. #



## 2.2-8 Replicate the Arc

[1] From **Modify** toolbox, select **Replicate**. Type 120 (degrees) for **r** (rotate). **Replicate** is equivalent to **Copy+Paste** (2.1-6[2, 5], pages 62, 63)

[2] Select the arc.

[3] Right-click-select **End/Set Paste Handle**.

[4] Select this vertex as paste handle. Before clicking, make sure a **P** (point) appears.

[5, 9] Right-click-select **Rotate by r** from the context menu.

[6] Click this vertex to paste the arc. Before clicking, make sure a **P** appears. If you have difficulty making **P** appear, see [7, 8].

[7] Whenever you have difficulty making **P** appear, click **Selection Filter: Points** in the toolbar. **Selection Filter** is also available in the context menu, (see [8]).

[8] **Selection Filter** is also available in the context menu.

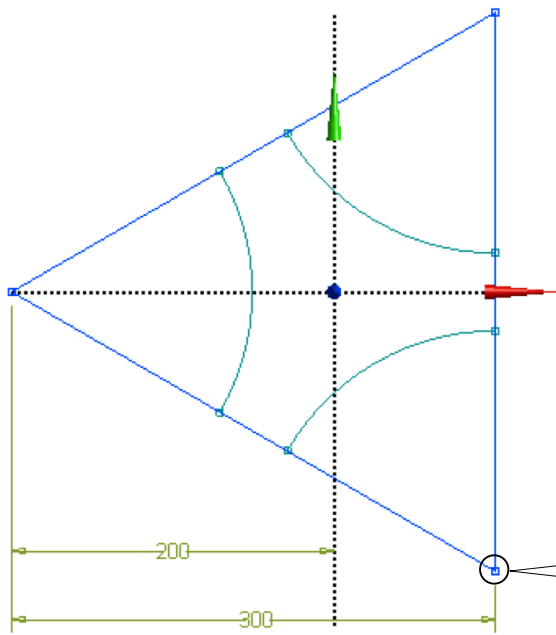

[10] Select this vertex to paste the arc. Before clicking, make sure a **P** appears.

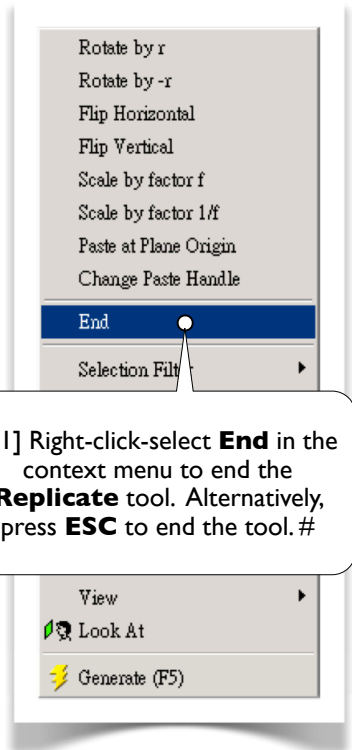

[11] Right-click-select **End** in the context menu to end the **Replicate** tool. Alternatively, press **ESC** to end the tool. #

We chose to manually set the paste handle at a vertex [4] (last page) because we want to demonstrate the use of **Set Paste Handle** [3] (last page). In this case, select **Use Plane Origin as Handle, Rotate by r**, and then **Paste at Plane Origin** have the same effect (similar to the steps in 2.1-6[4, 7], pages 62, 63).

### 2.2-9 Trim Away Unwanted Segments

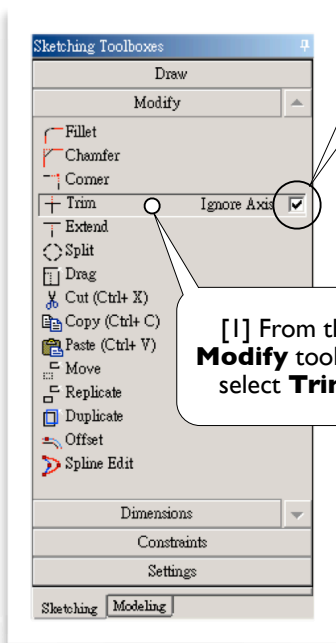

[2] Turn on **Ignore Axis** (2.1-8[2], page 64).

[1] From the **Modify** toolbox, select **Trim**.

[3] Click to trim away these 6 segments. #

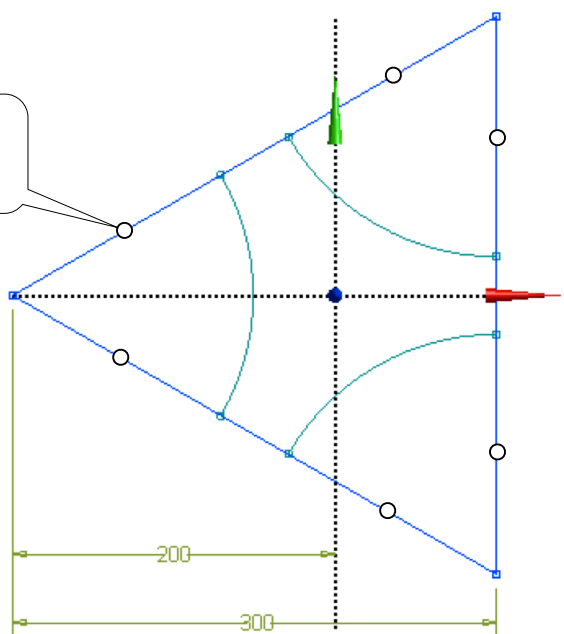

## 2.2-10 Impose Constraints

[1] From the **Constraints** toolbox, select **Equal Length**.

[2] Select this segment and the vertical segment to make their lengths equal.

[3] Select this segment and the vertical segment to make their lengths equal.

[4] Select **Symmetry**.

[5] Select the horizontal axis as the line of symmetry.

[6] Select the lower and upper arcs to make them symmetric. #

### Constraint Status

The three straight lines turn blue, indicating they are well-defined, while the three arcs remain greenish-blue, indicating they are not well-defined yet (under-constrained). Other color codes are: black for fixed, red for over-constrained, and gray for inconsistency.

## 2.2-11 Specify Dimension for Side Edges

[1] Select the **Dimension** toolbox and leave **General** as the default tool.

[2] Click the vertical segment and move the mouse rightward to create this dimension. All the entities turn to blue now. (The value 40 is typed in [3].)

[3] Type 40 (mm) for the new dimension. #

Details View	
Details of Sketch1	
Sketch	Sketch1
Sketch Visibility	Show Sketch
Show Constraints?	No
Dimensions: 3	
<input type="checkbox"/> H1	300 mm
<input type="checkbox"/> H2	200 mm
<input type="checkbox"/> V3	40 mm

## 2.2-12 Create Offset

[1] From the **Modify** toolbox, select **Offset**.

[2] Sweep-select all the segments (sweep each segment while holding your left mouse button down, see 2.1-7[2], page 63). Sweep-select is also called *paint-select*. (Also see [3].)

[3] Another way to select multiple entities is to switch **Select Mode** to **Box Select**, and then left-click-drag a box to select all entities inside the box.

[4] Right-click-select **End selection/Place Offset** in the context menu.

[5] Click roughly here to place the offset.

[6] Right-click-select **End** in the context menu, or press **ESC**, to close the **Offset** tool.

[7] From the **Dimension** toolbox, select **Horizontal**.

[8] Create this dimension by clicking the two arcs on the left and move downward. Note that all the entities turn to blue now.

[9] Type 30 (mm) for the new dimension.

[10] If you see something like this, never mind; there is nothing wrong with it. #

Details of Sketch1	
Sketch	Sketch1
Sketch Visibility	Show Sketch
Show Constraints?	No
Dimensions: 4	
<input type="checkbox"/> H1	300 mm
<input type="checkbox"/> H2	200 mm
<input type="checkbox"/> H4	30 mm
<input type="checkbox"/> V3	40 mm

## 2.2-13 Create Fillets

[1] In the **Modify** toolbox, select **Fillet**. Type 10 (mm) for **Radius**.

[2] Click these two segments to create a fillet. Repeat this step to create the other two fillets. The fillets are in greenish-blue color, indicating they are weakly defined (see [3]).

[3] Dimensions specified in a toolbox are "weak," meaning they may be overridden by other constraints or dimensions (also see 2.1-11 [5], page 66).

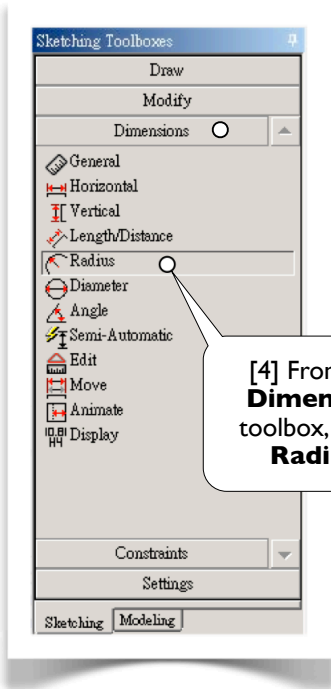

[4] From the **DIMENSION** toolbox, select **Radius**.

[5] Click one of the fillets to create this dimension. This turns a "weak" dimension to a "strong" one. Now, all the fillets are blue-colored. #

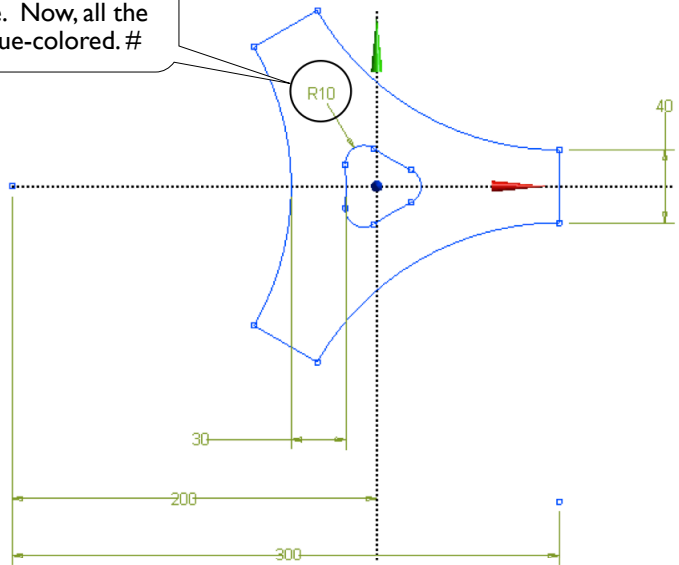

## 2.2-14 Extrude to Create 3D Solid

[1] Click the little cyan for an isometric view.

[2] Click **Extrude**.

[3] Type 10 (mm) for **Depth**. Note that **Sketch1** is automatically entered as **Geometry**.

[4] Click **Generate**.

[5] Click **Display Plane** to turn off the display of sketching plane.

[6] Click **Zoom to Fit**.

[7] Click all plus signs (+) to expand and browse the **model tree**. #

## 2.2-15 Save the Project and Exit Workbench

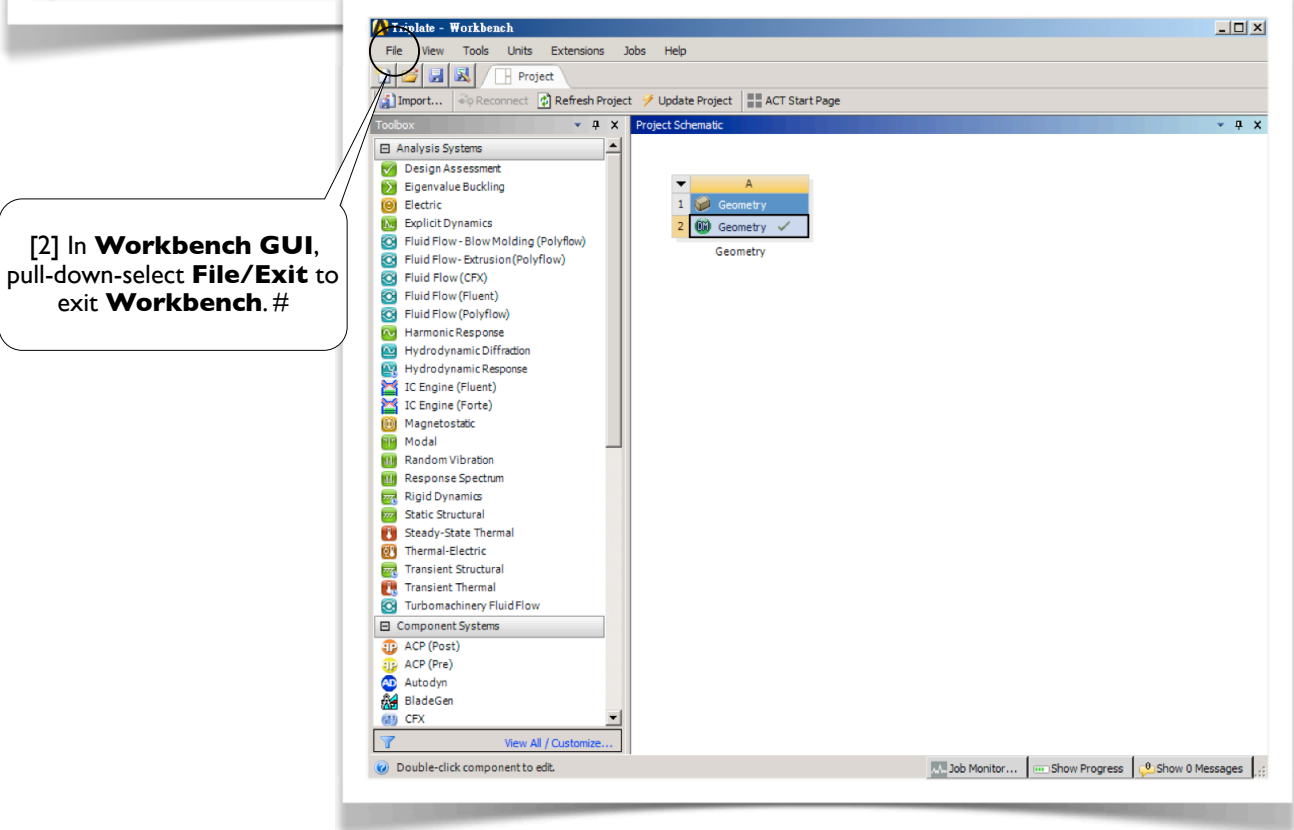
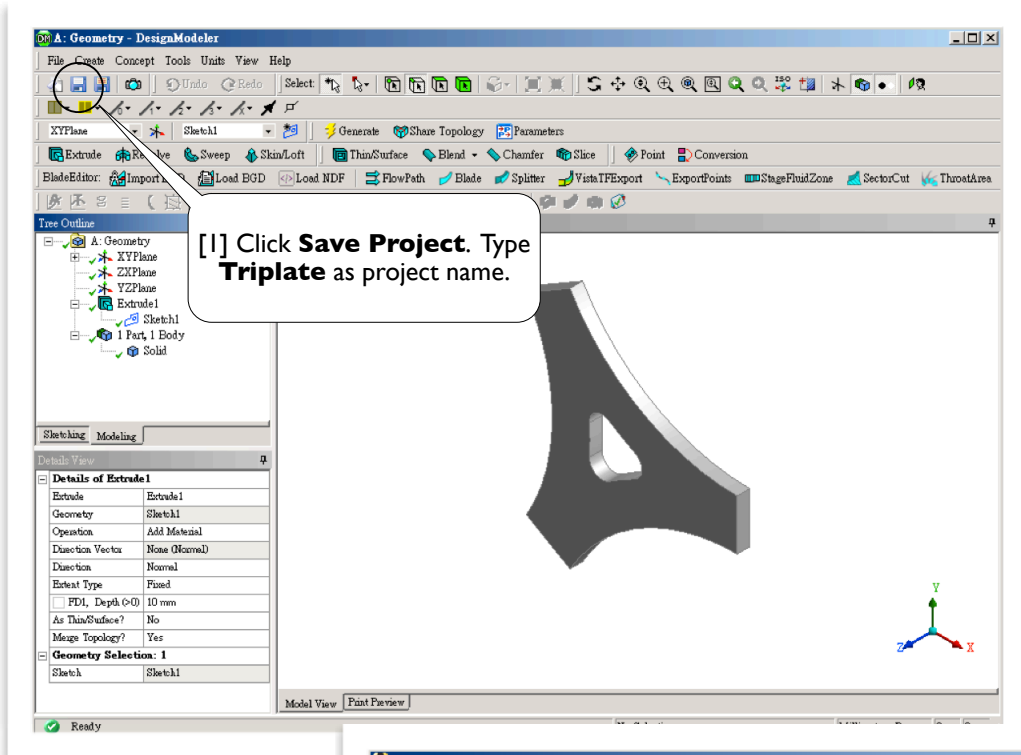

# Section 2.3

## More Details

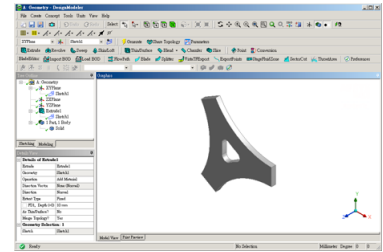

### 2.3-1 DesignModeler GUI

**DesignModeler GUI** consists of several areas [1-7]. On the top are **pull-down menus** and **toolbars** [1]; on the bottom is a **status bar** [7]. In-between are several **window panes**. **Separators** [8] between window panes can be dragged to resize the window panes. You even can make a window pane "float" by dragging or double-clicking its title bar. To return to its original position, simply double-click its title bar again.

**Tree Outline** [3] shares the same area with **Sketching Toolboxes** [4]. To switch between **Modeling** mode and **Sketching** mode, simply click a **mode tab** [2]. **Details View** [6] shows the detail information of the objects highlighted in **Tree Outline** [3] or **Graphics Window** [5]; the former displays a **Model Tree** (discussed next page) while the latter displays the geometric model. Note that we focus on 2D functions of **DesignModeler** in this chapter and will discuss 3D functions in Chapter 4.

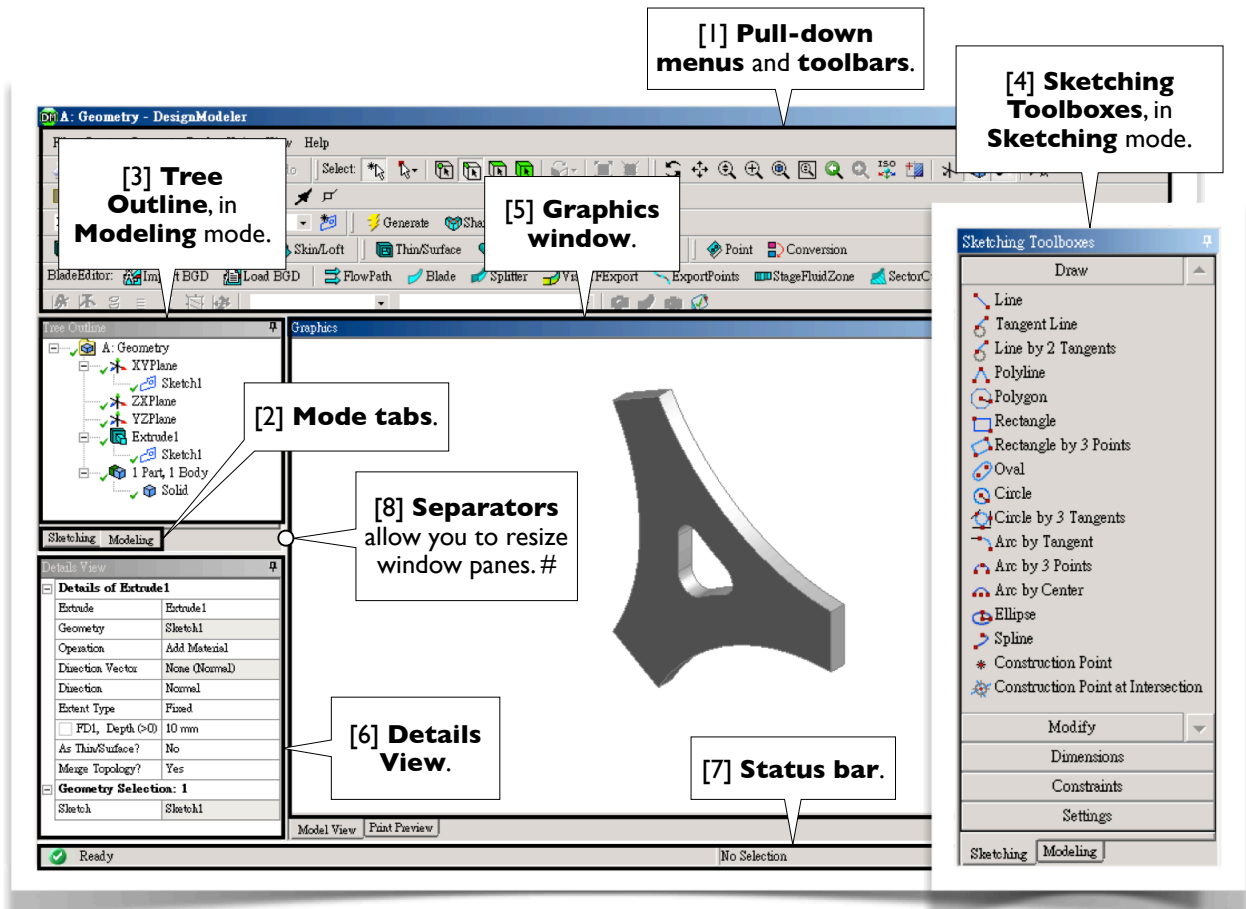



## Model Tree

**Tree Outline** [3] contains an outline of a **model tree**, the data structure of the geometric model. Each *branch* of the tree is called an *object*, which may contain one or more objects. At the bottom of the model tree is a **part** branch, which is the only object that will be exported to **Mechanical** for simulations. By right-clicking an object and selecting a tool from the *context menu*, you can operate on the object, such as delete, rename, duplicate, etc.

The order of the objects is relevant. **DesignModeler** renders the geometry according to the order of objects in the model tree. New objects are normally added one after another. If you want to insert a new object **BEFORE** an existing object, right-click the existing object and select **Insert/...** from the context menu. After insertion, **DesignModeler** will re-render the geometry.

### 2.3-2 Sketching Planes

A sketch must be created on a *sketching plane*, or simply called a *plane*; each plane may contain multiple sketches. In the beginning of a **DesignModeler** session, three planes are automatically created: **XYPlane**, **YZPlane**, and **ZXPlane**. The currently active plane is shown on the toolbar [1]. You can create as many new planes as needed [2]. There are several ways to create a new plane [3]. In this chapter, since we always create sketches on **XYPlane**, we will not discuss how to create sketching planes now and will discuss it in Chapter 4.

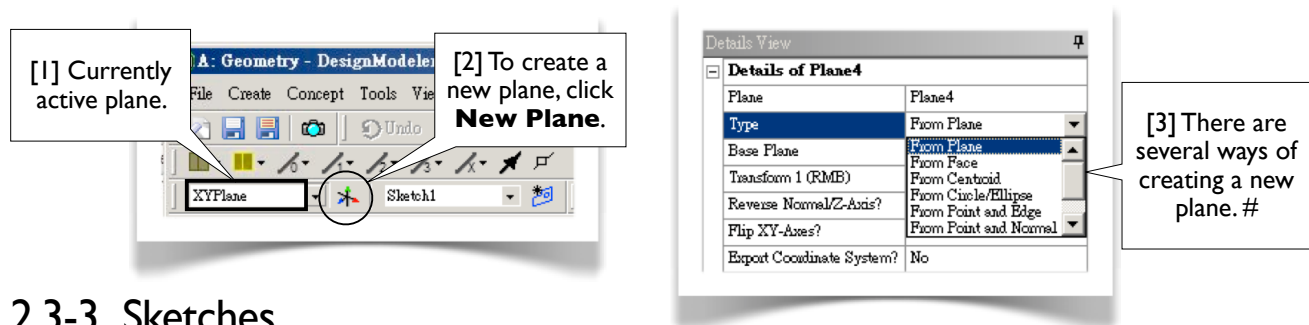

### 2.3-3 Sketches

A sketch consists of *points* and *edges*; edges may be straight lines or curves. Dimensions and constraints may be imposed on points and edges. As mentioned (2.3-2), multiple sketches may be created on a plane. To create a new sketch on a plane on which there are yet no sketches, you simply switch to **Sketching** mode and draw any geometric entities on it. Later, if you want to add a new sketch on that plane, you have to click **New Sketch** [1]. Exactly one plane and one sketch is active at a time [2-5]; newly created points and edges are added to the active sketch, and newly created sketches are added to the active plane. In this chapter, we almost exclusively work with a single sketch; the only exception is Section 2.6, in which a second sketch is used (2.6-4[1, 2], page 105). When a new sketch is created, it becomes the active sketch. More on creating sketches will be discussed in Chapter 4.

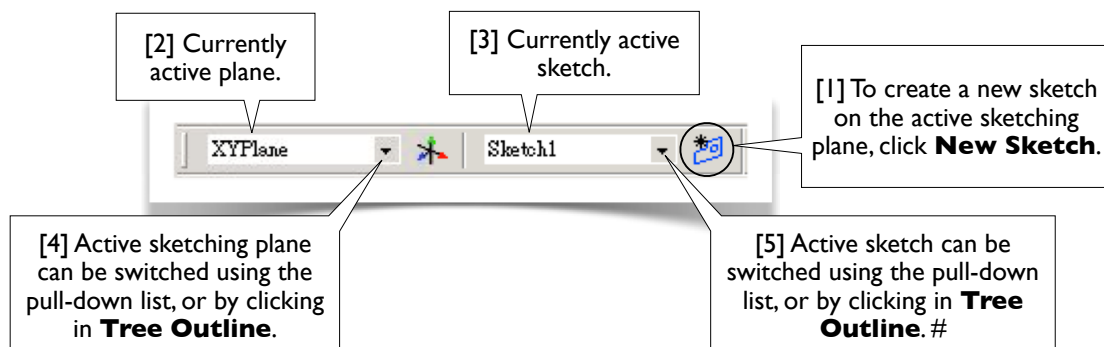

## 2.3-4 Sketching Toolboxes

When you switch to **Sketching** mode by clicking a mode tab (2.3-1[2], page 80), you see **Sketching Toolboxes** (2.3-1[4], page 80). There are five **Sketching Toolboxes: Draw, Modify, Dimensions, Constraints, and Settings** [1-5]. Most of the tools in the toolboxes are self-explained. The best way to learn these tools is to try them out individually. During the tryout, whenever you want to clean up the graphics window, pull-down-select **File/Start Over**. These sketching tools will be explained, starting from 2.3-6 (next page) until the end of this section.

Before we discuss these sketching tools, let's emphasize again some important tips about sketching.

### Pan, Zoom, and Box Zoom

Besides **Pan** tool (2.2-5[3], page 71), a sketch can also be panned by dragging your mouse while holding down both the control key and the middle mouse button (2.1-7[6], page 63). Besides **Zoom** tool (2.2-5[5], page 71) a sketch can also be zoomed in/out by simply rolling your mouse wheel (2.1-7[5], page 63); the cursor position is the "zoom center." Besides **Box Zoom** tool (2.2-5[4], page 71), box zoom can also be done by dragging a rectangle in the graphics window using the right mouse button (2.1-7[4], page 63). When you get used to these mouse shortcuts, you usually don't need **Pan, Zoom, and Box Zoom** tools (2.2-5[3, 4, 5], page 71).

### Context Menu

While most of the operations can be done by commands in pull-down menus or toolbars, many operations either require or are more efficient using a context menu. The context menu can be popped-up by right-clicking an entity in the graphics window or an object in the model tree. Try to explore whatever is available in the context menu.

### Status Bar

The status bar (2.3-1[7], page 80) contains instructions on each operation. Look at the instructions whenever helpful. When a draw tool is in use, the coordinates of your mouse pointer are shown in the status bar.

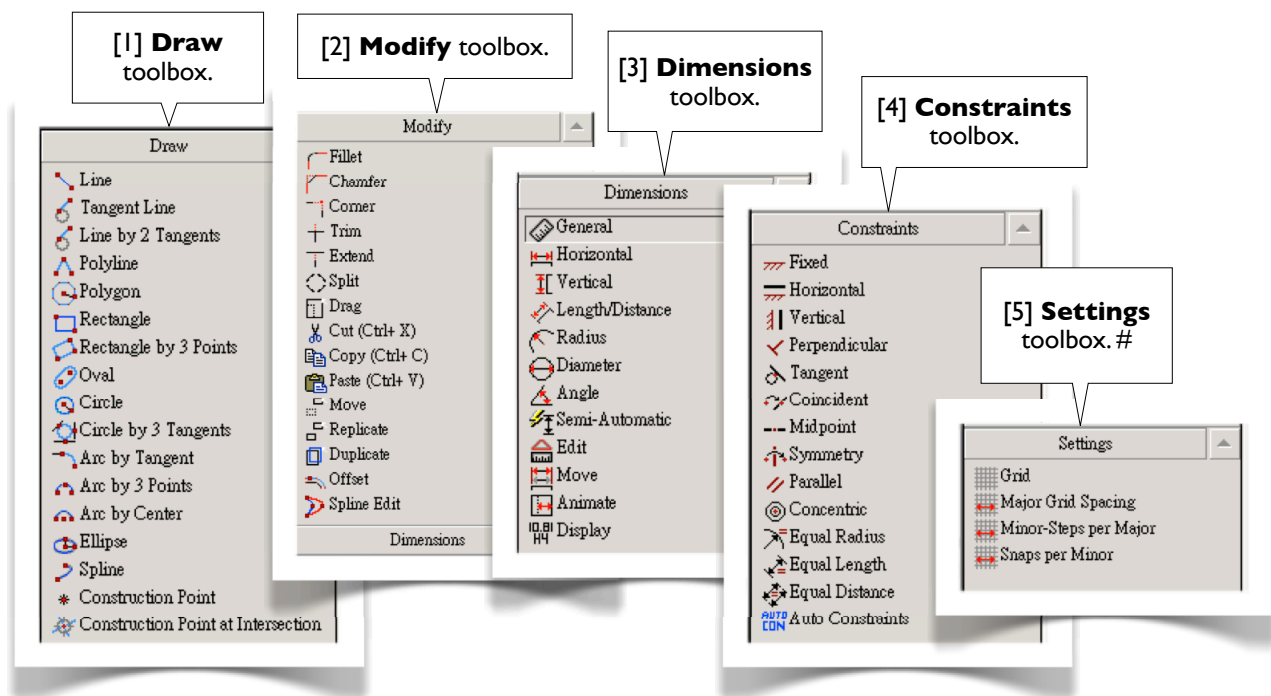

## 2.3-5 Auto Constraints<sup>[Refs 1,2]</sup>

By default, **DesignModeler** is in **Auto Constraints** mode, both globally and locally. **DesignModeler** attempts to detect the user's intentions and tries to automatically impose constraints on sketching entities. The following cursor symbols indicate the kind of constraints that are applied:

- C - The cursor is coincident with a line.
- P - The cursor is coincident with a point.
- T - The cursor is a tangent point.
- ⊥ - The cursor is a perpendicular foot.
- H - The line is horizontal.
- V - The line is vertical.
- // - The line is parallel to another line.
- R - The radius is equal to another radius.

Both **Global** and **Cursor** modes are based on all entities of the active plane (not just the active sketch). The difference is that **Cursor** mode only examines the entities nearby the cursor, while **Global** mode examines all the entities in the active plane.

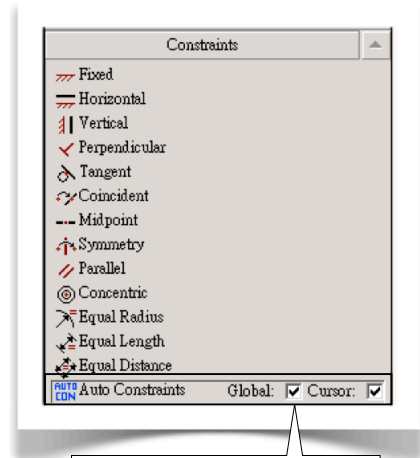

[1] By default, **DesignModeler** is in **Auto Constraints** mode, both globally and locally. #

## 2.3-6 Draw Tools<sup>[Ref 3]</sup> [1]

### Line

Draws a line by two clicks.

### Tangent Line

Click a point on a curve (e.g., circle, arc, ellipse, or spline) to create a line tangent to the curve at that point.

### Line by 2 Tangents

Click two curves to create a line tangent to these two curves. Click a curve and a point to create a line tangent to the curve and connecting to the point.

### Polyline

A polyline consists of multiple straight lines. A polyline must be completed by choosing either **Open End** or **Closed End** from the context menu [2].

### Polygon

Draws a regular polygon. The first click defines the center and the second click defines the radius of the circumscribing circle.

[1] Draw toolbox.

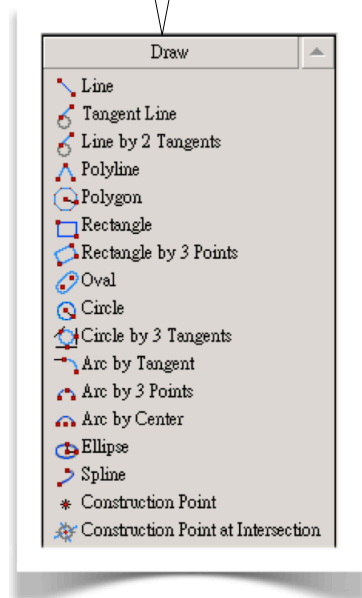

## Rectangle by 3 Points

The first two points define one side and the third point defines the other side.

## Oval

The first two clicks define two centers, and the third click defines the radius.

## Circle

The first click defines the center, and the second click defines the radius.

## Circle by 3 Tangents

Select three edges (lines or curves) to create a circle tangent to these three edges.

## Arc by Tangent

Click a point (usually an end point) on an edge to create an arc starting from that point and tangent to that edge; click a second point to define the other end and the radius of the arc.

## Arc by 3 Points

The first two clicks define the two ends of the arc, and the third click defines a point in-between the ends.

## Arc by Center

The first click defines the center, and two additional clicks define two ends.

## Ellipse

The first click defines the center, the second click defines the major radius, and the third click defines the minor radius.

## Spline

A spline is either rigid or flexible. A flexible spline can be edited or changed by imposing constraints, while a rigid spline cannot. After defining the last point, you must specify an ending condition [3]: either open end or closed end; either with fit points or without fit points.

## Construction Point at Intersection

Select two edges, a construction point will be created at the intersection.

[2] A polyline must be completed by choosing either **Open End** or **Closed End** from the context menu.

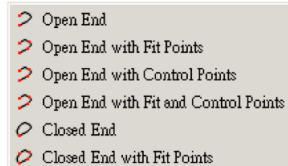
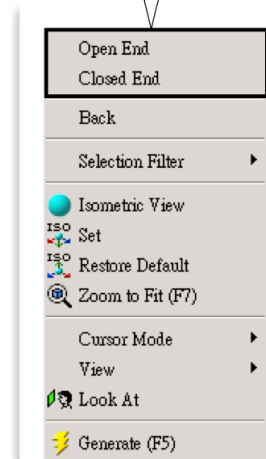

[3] A spline must be complete by specifying an ending condition from the context menu. #

## How to delete edges?

To delete edges, select them and choose **Delete** or **Cut** from the context menu. Multiple selection methods (e.g., control-selection or sweep-selection) can be used to select edges. To clean up the graphics window entirely, pull-down-select **File/Start Over**. A general way of deleting any sketching entities (edges, dimensions, or constraints) is to right-click the entity in **Details View** and issue **Delete**. See 2.3-8[6, 7] (page 88) and 2.3-9[3, 4] (page 89).

## How to abort a tool?

Simply press **ESC**.

## 2.3-7 Modify Tools<sup>[Ref 4]</sup> [1]

### Fillet

Select two edges or a vertex to create a fillet. The radius of the fillet can be specified in the toolbox [2]. Note that this radius value is a weak dimension; i.e., it can be changed by other dimensions or constraints.

### Chamfer

Select two edges or a vertex to create an equal-length chamfer. The sizes of the chamfer can be specified in the toolbox.

### Corner

Select two edges, and the edges will be trimmed or extended up to the intersection point and form a sharp corner. The clicking points decide which sides to be trimmed.

### Trim

Select an edge, and the portion of the edge will be removed up to its intersection with another edge, axis, or point.

### Extend

Select an edge, and the edge will be extended up to an edge or axis.

### Split

This tool splits an edge into several segments depending on the options from the context menu [3]. **Split Edge at Selection:** Click an edge, and the edge will be split at the clicking point. **Split Edges at Point:** Click a point, and all the edges passing through that point will be split at that point. **Split Edge at All Points:** Click an edge, the edge will be split at all points on the edge. **Split Edge into n Equal Segments:** Click an edge and specify a value  $n$ , and the edge will be split equally into  $n$  segments.

### Drag

Drags a point or an edge to a new position. All the constraints and dimensions are preserved.

### Copy

Copies the selected entities to a "clipboard." A **Paste Handle** must be specified using one of the methods in the context menu [4]. After completing this tool, **Paste** tool is automatically activated.

[1] **Modify** toolbox.

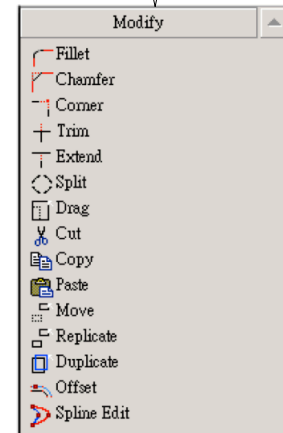

[2] Radii of fillets can be suggested; it is a "weak" dimension.

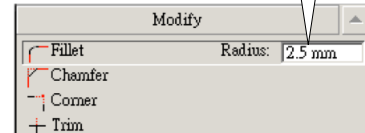

[3] Options of **Split** in the context menu.

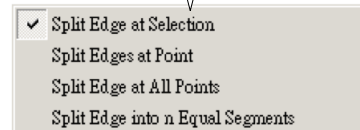

[4] Options of **Copy** in the context menu.

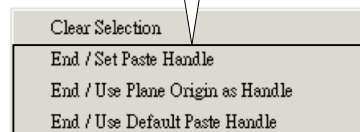

## Cut

Similar to **Copy**, except that the copied entities are removed.

## Paste

Pastes the entities in the "clipboard" to the graphics window. The click defines the point at which the **Paste Handle** positions. Many options can be chosen from the context menu [5], where the rotating angle  $r$  and the scaling factor  $f$  can be specified in the toolbox.

## Move

Equivalent to a **Cut** followed by a **Paste**. (The original is removed.)

## Replicate

Equivalent to a **Copy** followed by a **Paste**. (The original is preserved.)

## Duplicate

Similar to **Replicate**. However, **Duplicate** copies entities to the same position in the active plane. **Duplicate** can be used to copy features of a solid body or plane boundaries.

## Offset

Creates a set of edges that are offset by a distance from an existing set of edges.

## Spline Edit

Used to modify flexible splines. You can insert, delete, drag the fit points, etc [6]. For details, see the reference<sup>[Ref 4]</sup>.

## 2.3-8 Dimensions Tools<sup>[Ref 5]</sup> [1]

### General

Allows creation of any of the dimension types, depending on what edge and context-menu options are selected. If the selected edge is a straight line, the default dimension is its length [2]. If the selected edge is a circle or arc, the default dimension is its radius [3].

[5] Options of **Paste** in the context menu.

Rotate by  $r$  Degrees  
 Rotate by  $-r$  Degrees  
 Flip Horizontal  
 Flip Vertical  
 Scale by factor  $f$   
 Scale by factor  $1/f$   
 Paste at Plane Origin  
 Change Paste Handle

[6] Option of **Spline Edit** in the context menu. #

Select New Spline  
 Re-fit Spline  
 Create Missing Fit Points  
 Delete New Fit Points  
 Create Missing Control Points  
 Drag Fit Point  
 Drag Control Point  
 Insert Fit Point  
 Delete Fit Point

[1] **Dimension** toolbox.

Dimensions

- General
- Horizontal
- Vertical
- Length/Distance
- Radius
- Diameter
- Angle
- Semi-Automatic
- Edit
- Move
- Animate
- Display

## Horizontal

Select two points to specify a horizontal dimension. If you select an edge (instead of a point), the end point near the click will be picked.

## Vertical

Similar to **Horizontal**.

## Length/Distance

Select two points to specify a distance dimension. You also can select a point and a line to specify the distance between the point and the line.

## Radius

Select a circle or arc to specify a radius dimension. If you select an ellipse, the major (or minor) radius will be specified.

## Diameter

Select a circle or arc to specify a diameter dimension.

## Angle

Select two lines to specify an angle. By varying the selection order and location, you can control which angle you are dimensioning. The end of the lines that you select will be the direction of the hands, and the angle is measured counterclockwise from the first selected hand to the second. Before you click to locate the dimension, if the angle is not what you want, repeatedly choose **Alternate Angle** from the context menu until a correct angle is selected [4].

## Semi-Automatic

This tool displays a series of dimensions automatically to help you fully dimension the sketch.

## Edit

Click a dimension and this tool allows you to change its name or values.

## Move

Click a dimension and move it to a new position.

## Animate

Click a dimension to show the animated effects.

## Display

Allows you to decide whether to display dimension names, values, or both. In this book, we always choose to display dimension values [5] rather than dimension names.

[2] Options of **General** in the context menu if you select a line.

Horizontal  
Vertical  
Length/Distance  
Angle  
Select Pair

[3] Options of **General** in the context menu if you select a circle or arc.

Radius  
Diameter  
Select Pair

[4] Repeatedly choose **Alternate Angle** from the context menu until the correct angle is selected.

Alternate Angle  
Do Not Move with geometry  
Edit Name/Value

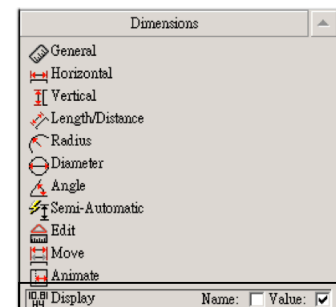

[5] In this book, we always display dimension values.

### How to delete dimensions?

To delete a dimension, select the dimension in **Details View**, and choose **Delete** from the context menu [6]. You can delete ALL dimensions by right-clicking **Dimensions** in **Details View** [7].

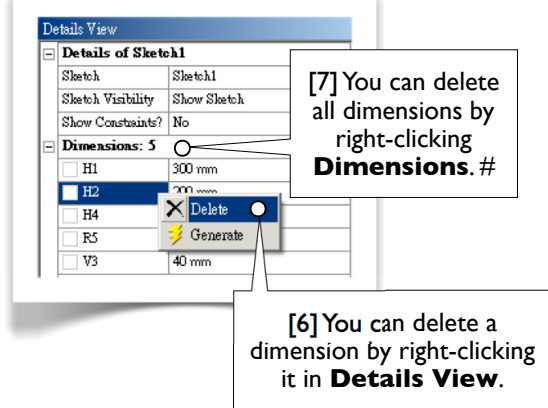

## 2.3-9 Constraints Tools<sup>[Ref 6]</sup> [1]

### Fixed

Applies on an edge to make it fully constrained if **Fix Endpoints** is selected [2]. If **Fix Endpoints** is not selected, then the edge's endpoints can be changed, but not the edge's position and slope.

### Horizontal

Applies to a line to make it horizontal.

### Vertical

Applies to a line to make it vertical.

### Perpendicular

Applies to two edges to make them perpendicular to each other.

### Tangent

Applies to two edges, one of which must be a curve, to make them tangent to each other.

### Coincident

Select two points to make them coincident. Or, select a point and an edge to make the edge or its extension pass through the point. There are other possibilities, depending on how you select the entities.

### Midpoint

Select a line and a point to make the midpoint of the line coincide with the point.

### Symmetry

Select a line or an axis, as the line of symmetry, and then select two entities to make them symmetric about the line of symmetry.

[1] **Constraints** toolbox.

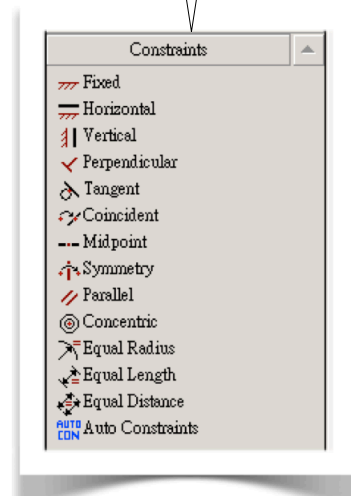

[2] If **Fix Endpoints** is selected, the edge will be fully constrained.

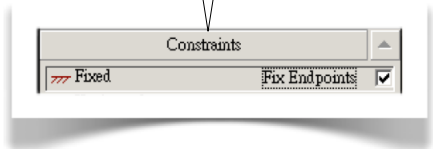



## Parallel

Applies to two lines to make them parallel to each other.

## Concentric

Applies to two curves, which may be circle, arc, or ellipse, to make their centers coincident.

## Equal Radius

Applies to two curves, which must be circle or arc, to make their radii equal.

## Equal Length

Applies to two lines to make their lengths equal.

## Equal Distance

Applies to two distances to make them equal. A distance can be defined by selecting two points, two parallel lines, or one point and one line.

## Auto Constraints

Allows you to turn on/off **Auto Constraints** (2.3-5, page 83).

### How to delete constraints?

By default, constraints are not displayed in **Details View**. To display constraints, select **Yes** for **Show Constraints?** in **Details View** [3]. To delete a constraint, right-click the constraint and issue **Delete** [4].

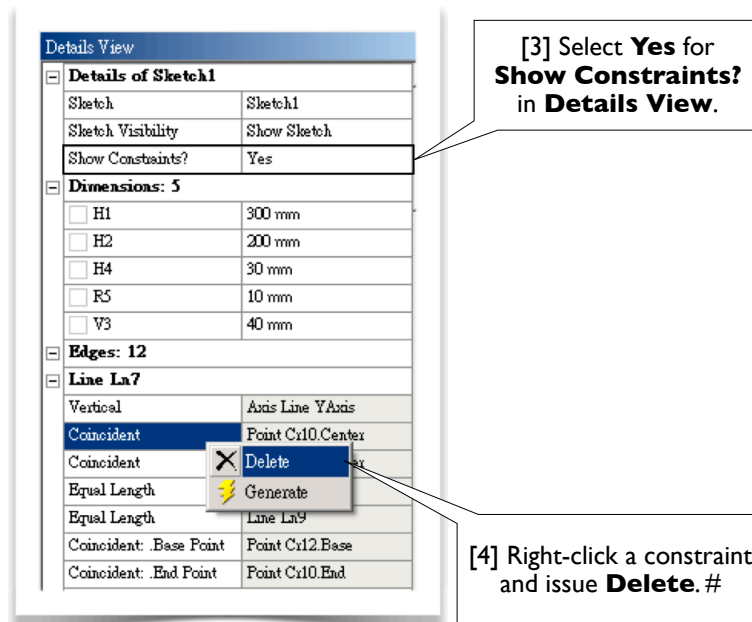

## 2.3-10 Settings Tools<sup>[Ref 7]</sup> [1]

### Grid

Allows you to turn on/off grid visibility and snap capability [2, 3]. The grid is not required to enable snapping.

### Major Grid Spacing

Allows you to specify **Major Grid Spacing** [4, 5] if **Show in 2D** is turned on.

### Minor-Steps per Major

Allows you to specify **Minor-Steps per Major** [6, 7] if **Show in 2D** is turned on.

### Snaps per Minor

Allows you to specify **Snaps per Minor** [8] if **Snap** is turned on.

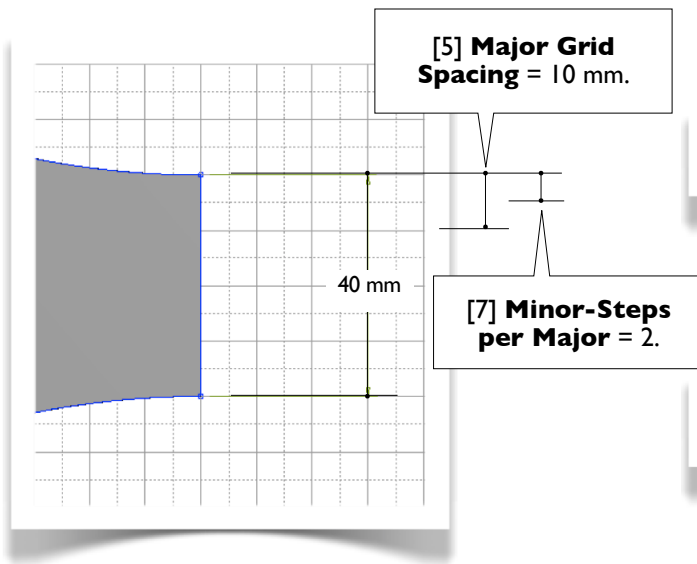
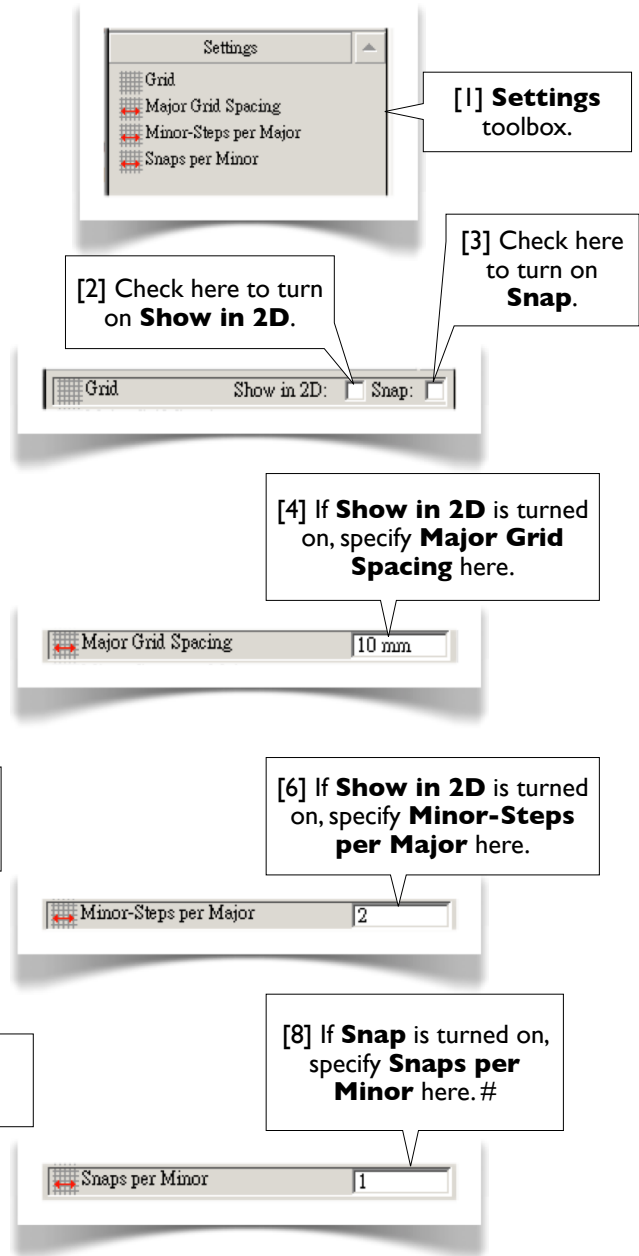

### References

1. ANSYS Documentation//DesignModeler User's Guide//2D Sketching//Auto Constraints
2. ANSYS Documentation//DesignModeler User's Guide//2D Sketching//Constraints Toolbox//Auto Constraints
3. ANSYS Documentation//DesignModeler User's Guide//2D Sketching//Draw Toolbox
4. ANSYS Documentation//DesignModeler User's Guide//2D Sketching//Modify Toolbox
5. ANSYS Documentation//DesignModeler User's Guide//2D Sketching//Dimensions Toolbox
6. ANSYS Documentation//DesignModeler User's Guide//2D Sketching//Constraints Toolbox
7. ANSYS Documentation//DesignModeler User's Guide//2D Sketching//Settings Toolbox

# Section 2.4

## M20x2.5 Threaded Bolt

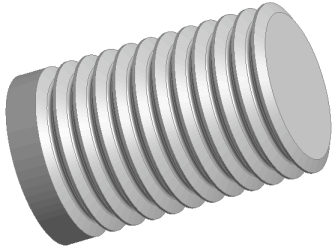

### 2.4-1 About the M20x2.5 Threaded Bolt<sup>[Refs 1, 2]</sup>

In this section, we'll create a sketch, revolving the sketch 360° to generate a 3D solid body, a body representing a portion of an M20x2.5 threaded bolt [1-6]. We will use this sketch in Section 3.2 again to generate a 2D solid body, which is then used for a static structural simulation.

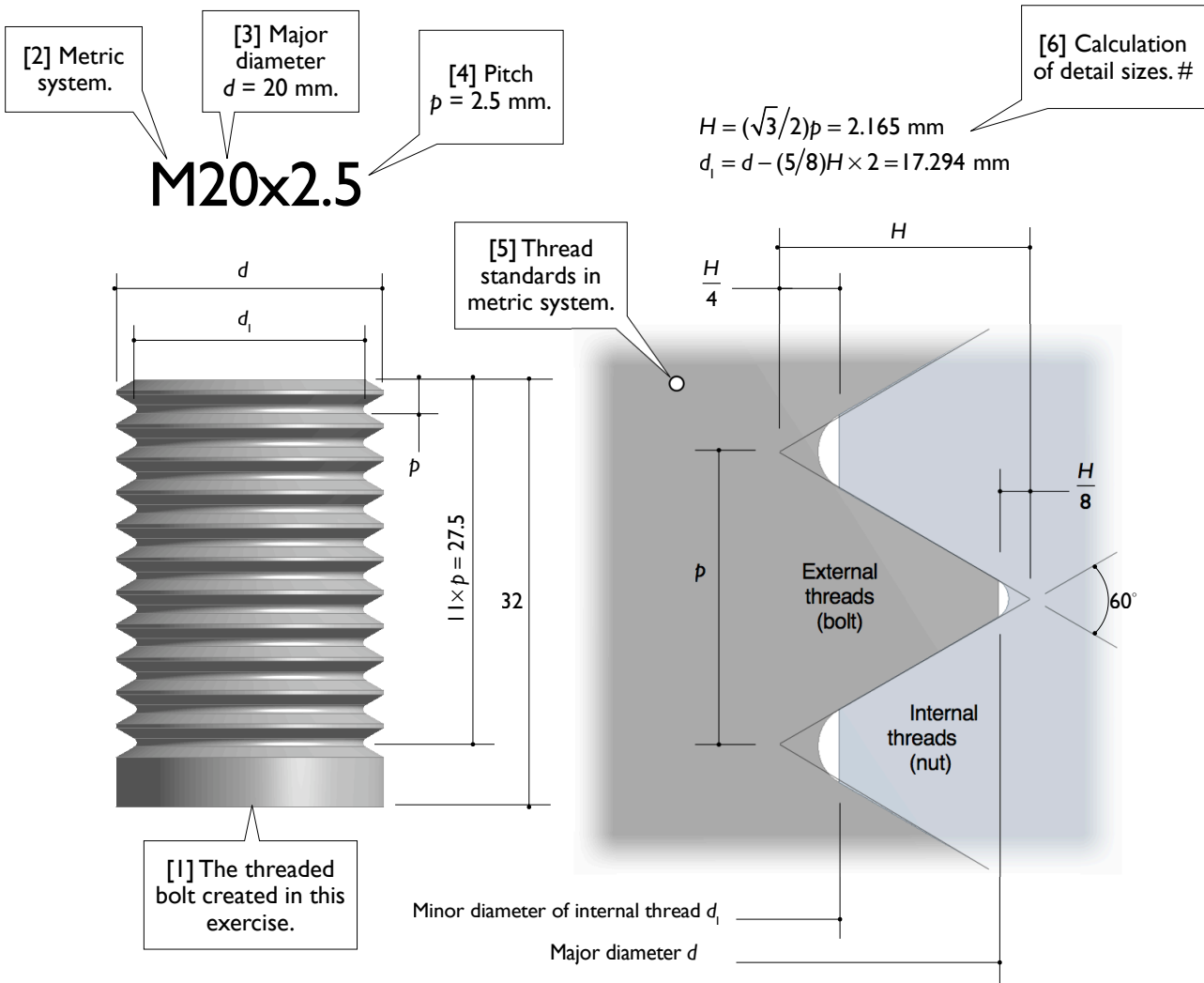

## 2.4-2 Draw a Horizontal Line

Launch **Workbench** and create a **Geometry** system.  
 Save the project as **Threads**. Start up **DesignModeler**.  
 Select **Millimeter** as the length unit.

On **XYPlane**, draw a horizontal line. Specify the dimensions (8.647 mm and 27.5 mm) as shown [1].

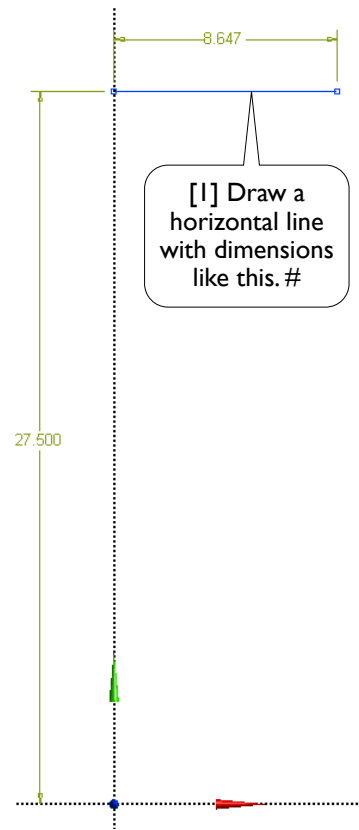

## 2.4-3 Draw a Polyline

Draw a polyline of 3 segments and specify dimensions (30°, 60°, 60°, 0.541 mm, and 2.165 mm) as shown [1-2]. To specify angle dimensions, please see **Angle**, 2.3-8, page 87.

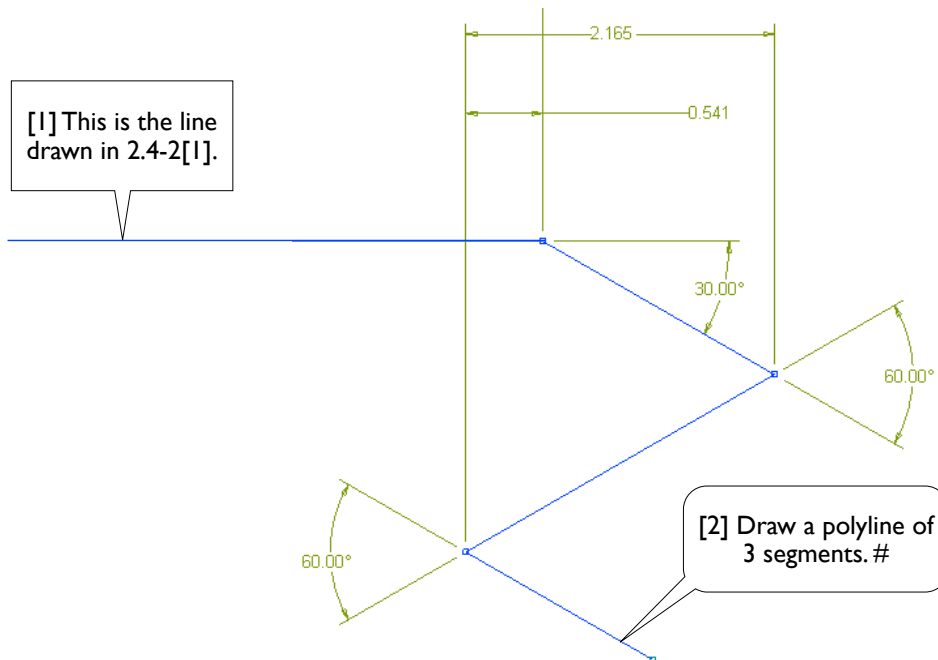

### 2.4-4 Draw Fillets

Draw a vertical line and specify its position [1].  
Create a fillet and specify its position [2-3].

[1] Draw a vertical line and specify its position (0.271 mm).

[2] Create a fillet (also see [3]) and specify its position (0.541 mm).

[3] Before creating fillets, specify an approximate radius value, say 0.5 mm. #

2.165  
0.541  
0.541  
0.271  
30.00°  
60.00°  
60.00°

Modify  
Fillet Radius: 0.5 mm

The diagram shows a technical sketch of a bolt head profile. A vertical line is drawn at a distance of 0.271 mm from the right edge. A fillet is applied at a distance of 0.541 mm from the left edge. The sketch includes dimensions: 2.165 mm for the total width, 0.541 mm for the fillet position, and 0.271 mm for the vertical line position. Angles of 30.00° and 60.00° are indicated. A software interface shows the 'Modify' dialog for the 'Fillet' tool with a radius of 0.5 mm.

### 2.4-5 Trim Away Unwanted Segments

[1] Trim away these three segments.

[2] The sketch after trimming. #

2.165  
0.541  
0.541  
0.271  
30.00°  
60.00°  
60.00°

The diagram shows the same sketch as in 2.4-4, but with three segments of the profile trimmed away. The dimensions and angles remain the same. Callout [1] points to the segments to be removed, and callout [2] shows the final sketch after trimming.

## 2.4-6 Replicate 10 Times

Select the **Replicate** tool and select all segments except the horizontal line (totaling 4 segments), and replicate 10 times. Set the **Paste Handle** as shown [1]. You may need to use **Selection Filter: Points** [2] (also see 2.2-8[7-8], page 73).

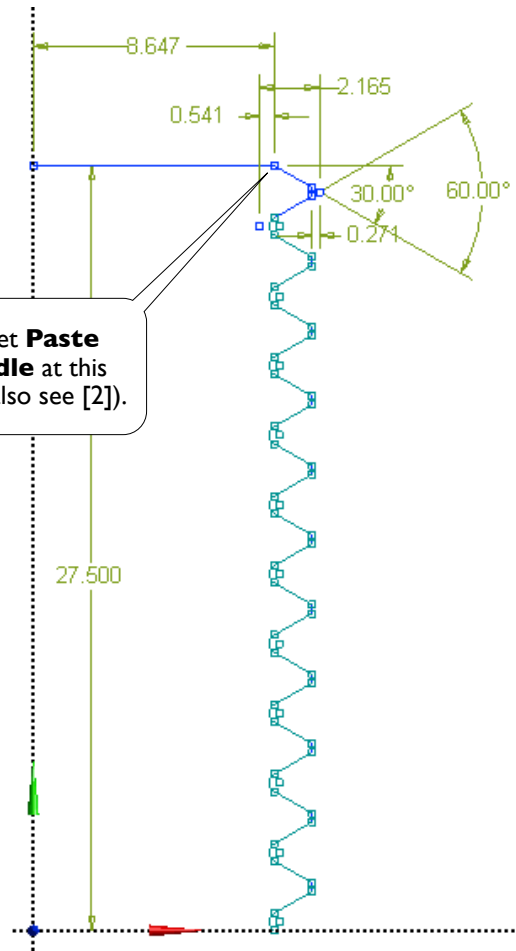
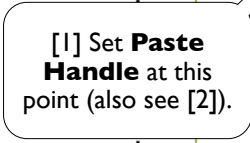
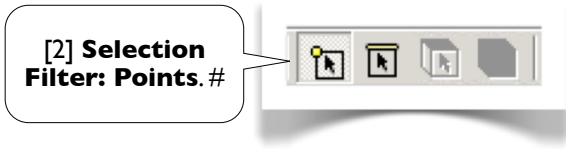

## 2.4-7 Complete the Sketch

Follow steps [1-5] to complete the sketch.

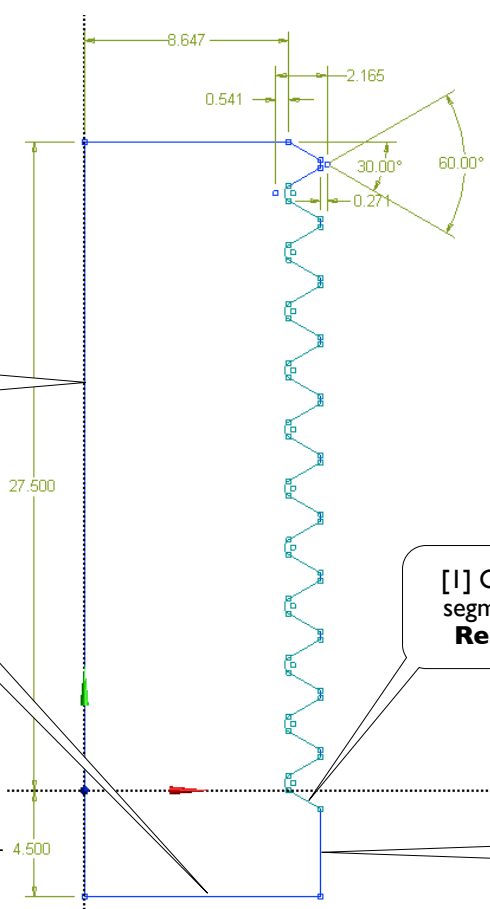
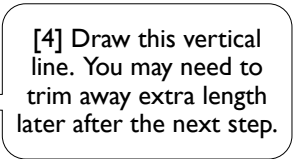
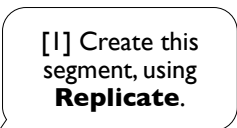
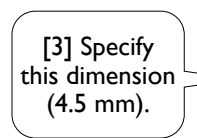
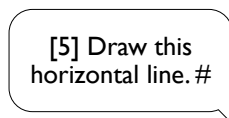
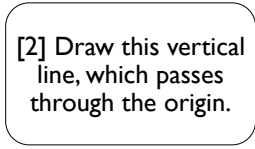

## 2.4-8 Revolve to Create 3D Solid

Click **Revolve** to generate a solid of revolution. Select the Y-axis as the axis of revolution [1]. Remember to click **Generate**.

Save the project and exit from **Workbench**. We will resume this project in Section 3.2.

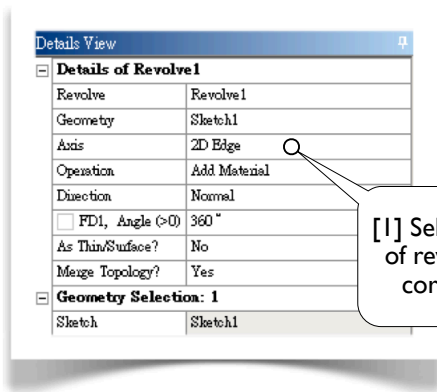
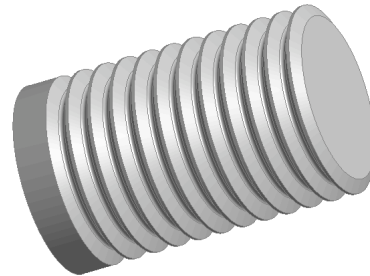

[1] Select the Y-axis as the **Axis** of revolution. (Make sure you correctly select the Y-axis.)

### References

1. Zahavi, E., *The Finite Element Method in Machine Design*, Prentice-Hall, 1992; Chapter 7. Threaded Fasteners.
2. Deutschman, A. D., Michels, W. J., and Wilson, C. E., *Machine Design: Theory and Practice*, Macmillan Publishing Co., Inc., 1975; Section 16-6. Standard Screw Threads.

# Section 2.5

## Spur Gears

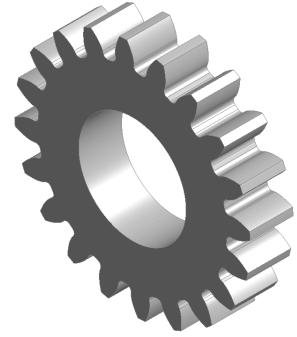

Subsections 2.5-1 and 2.5-2 detail the geometry of the spur gear used in this section. If you are not interested in these geometric details for now, you may skip them and jump directly to 2.5-3 (page 98).

### 2.5-1 About the Spur Gears<sup>[Refs 1,2]</sup>

The figure below shows a pair of identical spur gears in mesh [1-4]. Spur gears have their teeth cut parallel to the axis of the shaft on which the gears are mounted, transmitting power between the parallel shafts. To maintain a constant angular velocity ratio, two meshing gears must satisfy a fundamental law of gearing: the shape of the teeth must be such that the common normal [8] at the point of contact between two teeth must always pass through a fixed point on the line of centers<sup>[Ref 1]</sup> [5]. This fixed point is called the *pitch point* [6].

The angle between the line of action [8] and the common tangent of the pitch circles [7] is known as the *pressure angle*. The parameters defining a spur gear are its pitch radius ( $r_p = 2.5$  in) [3], pressure angle ( $\alpha = 20^\circ$ ) [8], and number of teeth ( $N = 20$ ). The teeth are cut with a radius of addendum  $r_a = 2.75$  in [9] and a radius of dedendum  $r_d = 2.2$  in [10]. The shaft has a radius of 1.25 in [11]. All fillets have a radius of 0.1 in [12]. The thickness of the gear is 1.0 in.

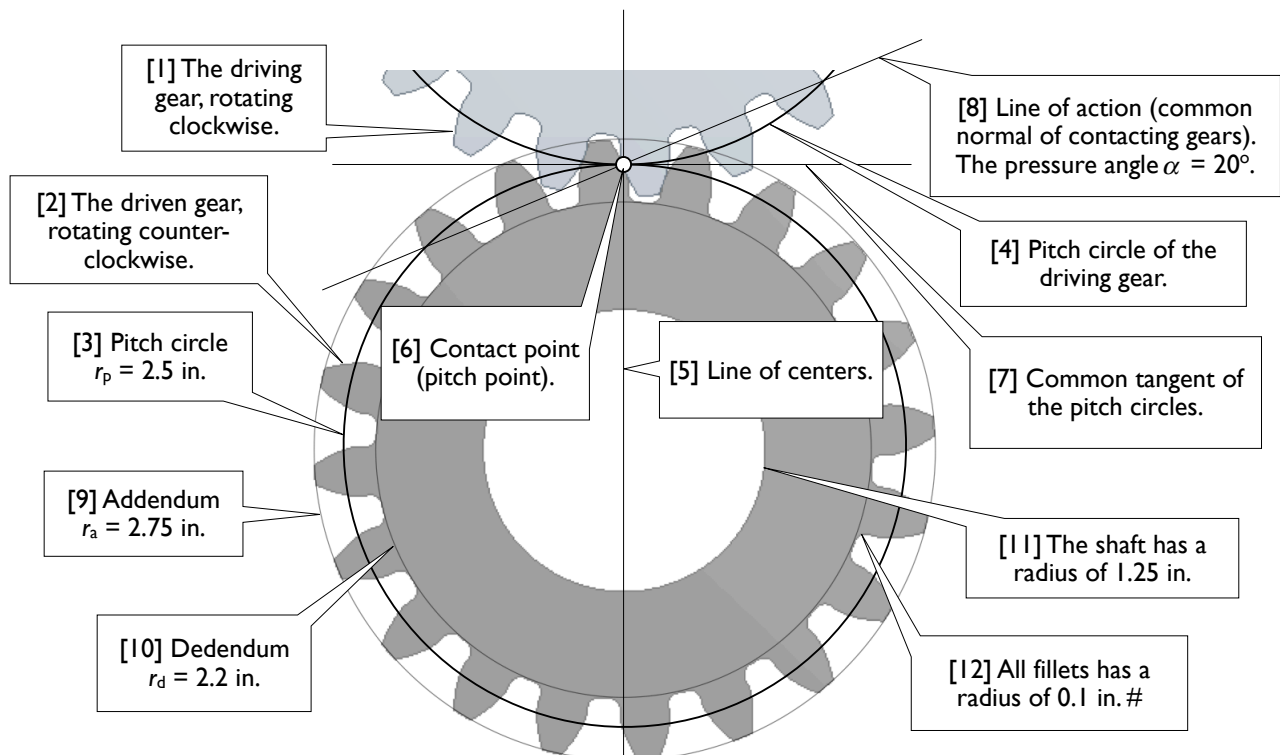



## 2.5-2 About Involute Curves<sup>[Refs 1,2]</sup>

To satisfy the fundamental law of gearing, gear profiles are usually cut to an *involute curve* [1], which may be constructed by wrapping a string (*BA*) around a *base circle* [2], and then tracing the path (*A-P-F*) of a point (*A*) on the string.

Given the gear's pitch radius  $r_p$  and pressure angle  $\alpha$ , we can calculate the coordinates of each point on the involute curve. For example, let's calculate the polar coordinates  $(r, \theta)$  of an arbitrary point *A* [3] on the involute curve. Note that *BA* and *CP* are tangent lines of the base circle, and *F* is a foot of perpendicular.

Since *APF* is an involute curve and *BCDEF* is the base circle, by the definition of involute curve,

$$\overline{BA} = \overline{BCDEF} \quad (1)$$

$$\overline{CP} = \overline{CDEF} \quad (2)$$

In  $\triangle OCP$ ,

$$r_b = r_p \cos \alpha \quad (3)$$

In  $\triangle OBA$ ,

$$r = \frac{r_b}{\cos \phi} \quad (4)$$

Or,

$$\phi = \cos^{-1} \frac{r_b}{r} \quad (5)$$

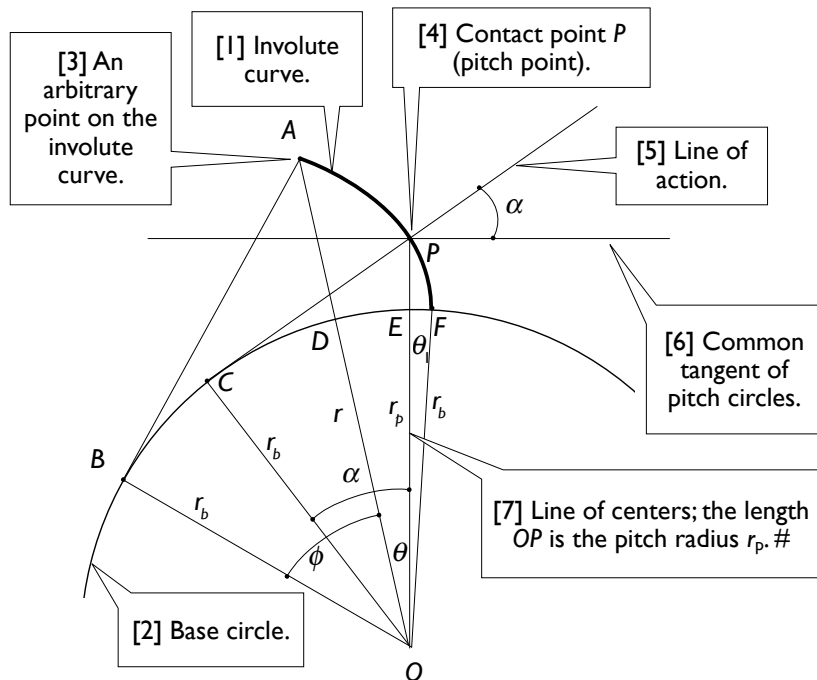

To calculate  $\theta$ , we notice that

$$\widehat{DE} = \widehat{BCDEF} - \widehat{BCD} - \widehat{EF}$$

Dividing the equation with  $r_b$  and using Eq. (1),

$$\frac{\widehat{DE}}{r_b} = \frac{\overline{BA}}{r_b} - \frac{\widehat{BCD}}{r_b} - \frac{\widehat{EF}}{r_b}$$

If radian is used, then the above equation can be written as

$$\theta = (\tan \phi) - \phi - \theta_1 \quad (6)$$

The last term  $\theta_1$  is the angle  $\angle EOF$ , which can be calculated by dividing Eq. (2) with  $r_b$ ,

$$\frac{\overline{CP}}{r_b} = \frac{\widehat{CDEF}}{r_b}, \text{ or } \tan \alpha = \alpha + \theta_1, \text{ or}$$

$$\theta_1 = (\tan \alpha) - \alpha \quad (7)$$

We'll show how to calculate polar coordinates  $(r, \theta)$  using Eqs. (3-7). The polar coordinates then can be easily transformed to rectangular coordinates, using *O* as origin and *OP* as *y*-axis,

$$x = -r \sin \theta, \quad y = r \cos \theta \quad (8)$$

## Numerical Calculations of Coordinates

In our case, the pitch radius  $r_p = 2.5$  in, and pressure angle  $\alpha = 20^\circ$ ; from Eqs. (3) and (7) respectively,

$$r_b = 2.5 \cos 20^\circ = 2.349232 \text{ in}$$

$$\theta_1 = \tan 20^\circ - \frac{20^\circ}{180^\circ} \pi = 0.01490438 \text{ (rad)}$$

The table below lists the calculated coordinates. The values in the first column ( $r$ ) are chosen such that, except the pitch point ( $r = 2.5$  in), the intermediate points are at the quarter points between  $r_b$  ( $r = 2.349232$  in) and  $r_o$  ( $r = 2.75$  in). Also note that, when using Eqs. (6) and (7), radians are used as the unit of angles; in the table below, however, degrees are used.

$r$ in.	$\phi$ Eq. (5), degrees	$\theta$ Eq. (6), degrees	$x = -r \sin \theta$ in.	$y = r \cos \theta$ in.
2.349232	0.000000	-0.853958	-0.03501	2.3490
2.449424	16.444249	-0.387049	-0.01655	2.4494
2.500000	20.000000	0.000000	0.00000	2.5000
2.549616	22.867481	0.442933	0.01971	2.5495
2.649808	27.555054	1.487291	0.06878	2.6489
2.750000	31.321258	2.690287	0.12908	2.7470

### 2.5-3 Draw an Involute Curve

Launch **Workbench**. Create a **Geometry** system. Save the project as **Gear**. Start up **DesignModeler**. Select **Inch** as the length unit. Start to draw sketch on the **XYPlane**.

In the **Draw** toolbox, select **Construction Point**, draw 6 points and specify dimensions as shown. Note that the vertical dimensions are measured from the **X**-axis and the pitch point [1] is coincident with the **Y**-axis.

Connect these six points using the **Spline** tool in the **Draw** toolbox, leave **Flexible** option on, and finish the spline with **Open End**.

It is equally good that you draw the spline by using the **Spline** tool directly without first creating construction points. Select **Open End with Fit Points** from the context menu at the end of the **Spline** tool. After dimensioning each point, use the **Spline Edit** tool to edit the spline and select **Re-fit Spline** [2] from the context menu to smooth out the spline.

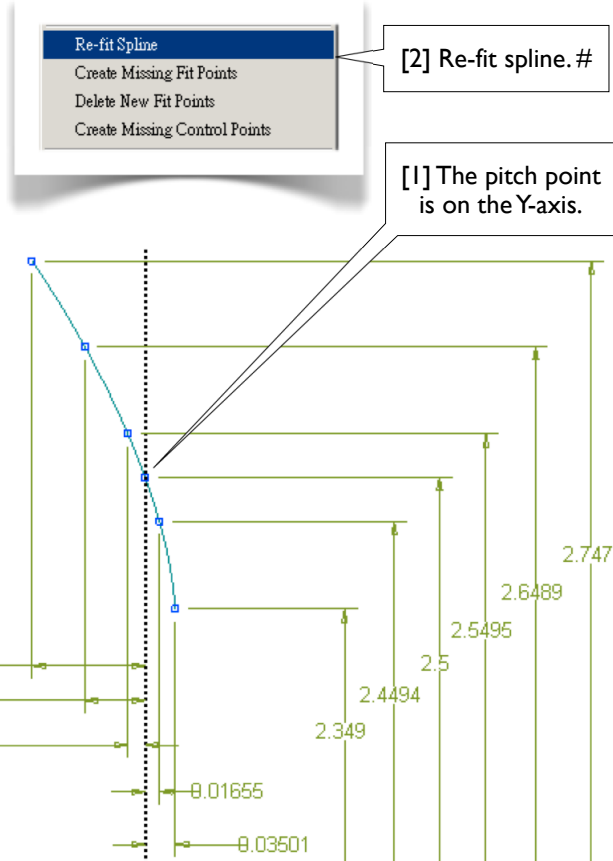

### 2.5-4 Draw Circles

Draw three circles using the **Circle** tool in the **Draw** toolbox [1-3]. Let the addendum circle "snap" to the outermost construction point [3]. Specify radii for the shaft circle (1.25 in) and the dedendum circle (2.2 in).

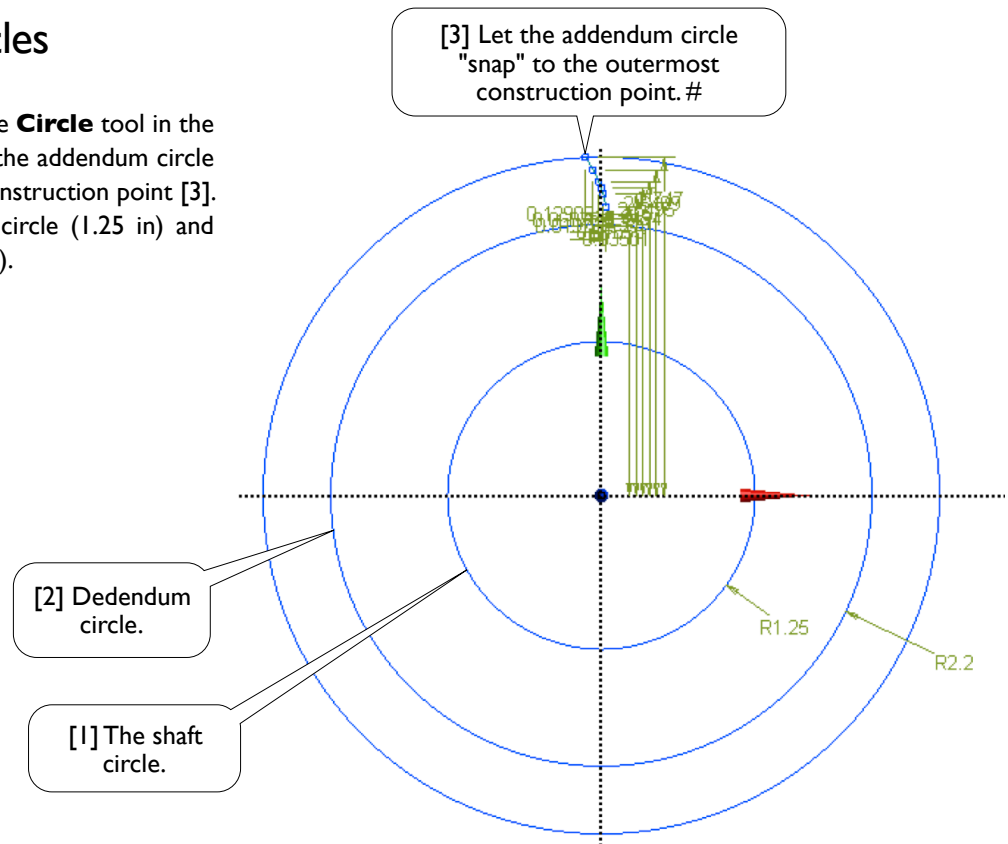

### 2.5-5 Complete the Tooth Profile

Draw a line from the lowest construction point to the dedendum circle, and make it perpendicular to the dedendum circle by using the **Perpendicular** tool in the **Constraints** toolbox [1-3]. When drawing the line, avoid a **V** auto-constraint (since this line is NOT vertical). Draw a fillet [4] of radius 0.1 in to complete the profile of a tooth.

Sometimes, turning off **Display Plane** may be helpful to work on the graphics window [5]. In this case, all the dimensions referring to the plane axes disappear.

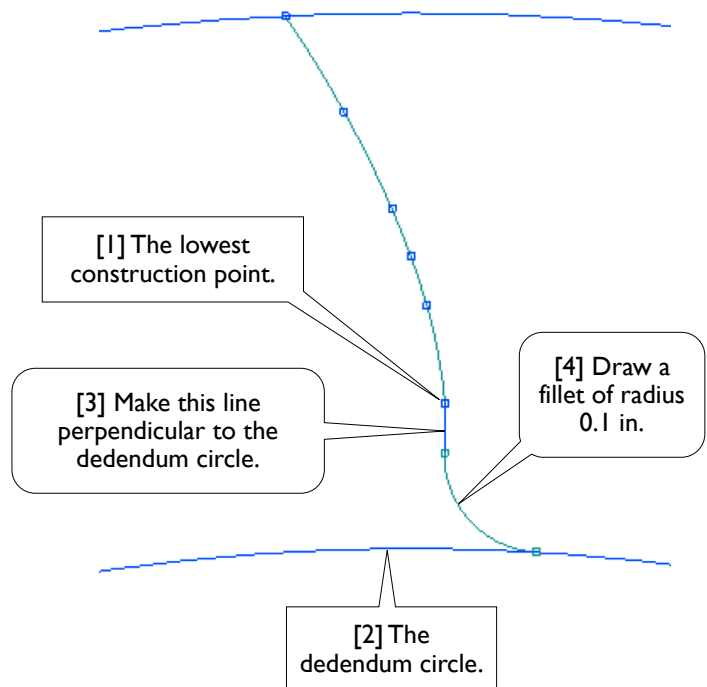
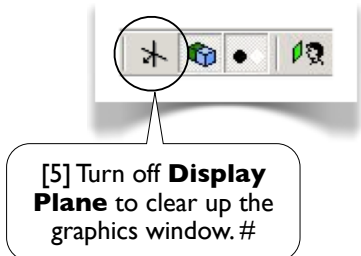

## 2.5-6 Replicate the Profile

Select the **Replicate** tool, type 9 (degrees) for **r**. Select the profile (3 segments), **End/Use Plane Origin as Handle, Flip Horizontal, Rotate by r**, and **Paste at Plane Origin [1]**. End **Replicate** tool by pressing **ESC**.

Note that the gear has 20 teeth, each spanning 18 degrees. The angle between the two pitch points is 9 degrees.

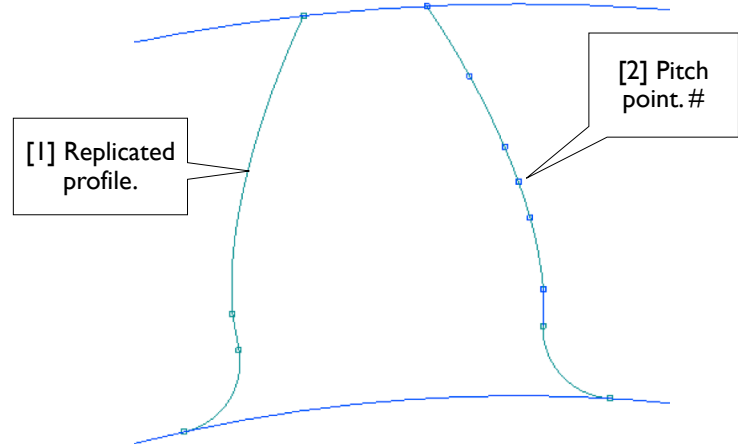

## 2.5-7 Replicate the Tooth 19 Times

Click **Replicate** tool again, type 18 (degrees) for **r**. Select both left and right profiles (6 segments), **End/Use Plane Origin as Handle, Rotate by r**, and **Paste at Plane Origin**. Repeat the last two steps (rotate and paste) until completing a full circle (totaling 20 teeth).

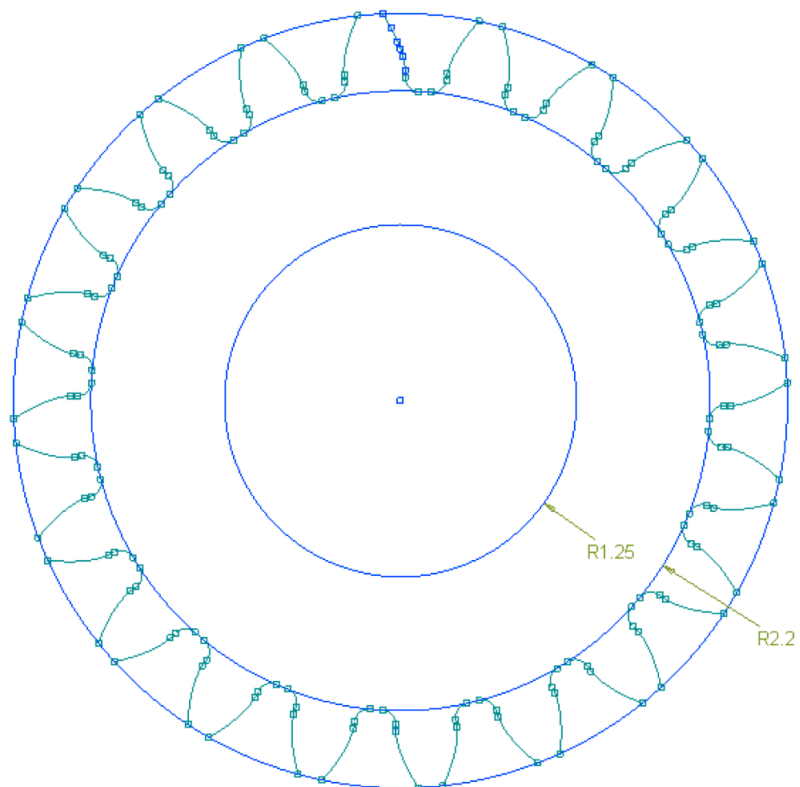

## 2.5-8 Trim Away Unwanted Segments

Trim away unwanted segments in the addendum circle and the dedendum circle, as shown.

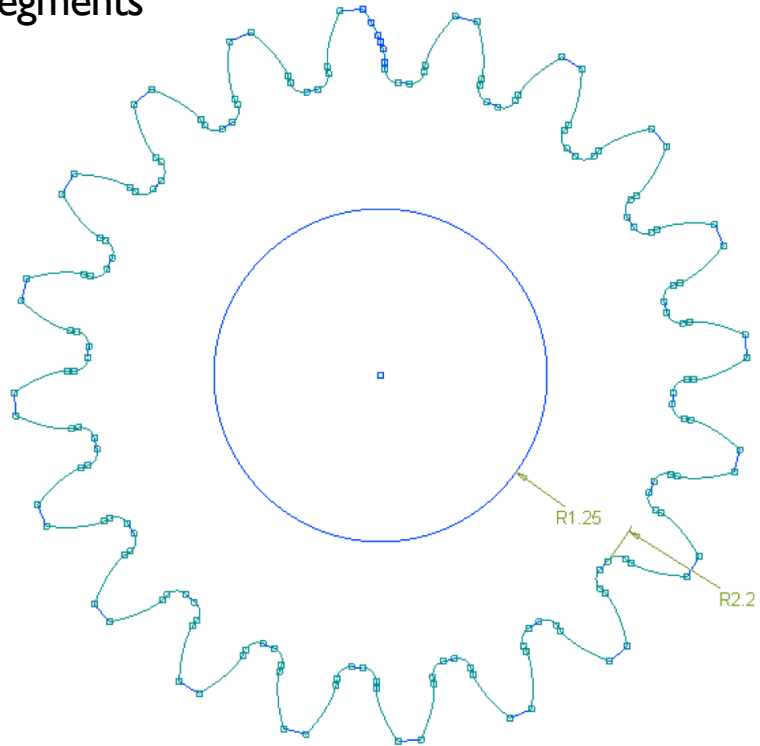

## 2.5-9 Extrude to Create 3D Solid

Extrude the sketch 1.0 inch to create a 3D solid. Save the project and exit from **Workbench**. We will resume this project again in Section 3.4.

It is equally good that you create a single tooth (a 3D solid body) and then duplicate it by using **Create/Pattern** in the **Modeling** mode. In this exercise, however, we use **Replicate** in **Sketching** mode because our purpose in this chapter is to practice sketching techniques.

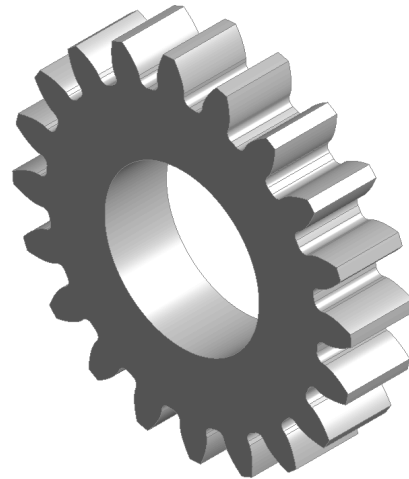

## References

1. Deutschman, A. D., Michels, W. J., and Wilson, C. E., *Machine Design: Theory and Practice*, Macmillan Publishing Co., Inc., 1975; Chapter 10. Spur Gears.
2. Zahavi, E., *The Finite Element Method in Machine Design*, Prentice-Hall, 1992; Chapter 9. Spur Gears.

# Section 2.6

## Microgripper

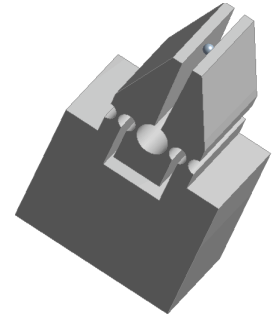

### 2.6-1 About the Microgripper<sup>[Refs 1,2]</sup>

The microgripper is made of a polymer material, actuated by a shape memory alloy (SMA) actuator [1-3], its motion caused by temperature change, the temperature in turn controlled by electric current. In the lab, the microgripper is tested by gripping a steel bead of a diameter of 30 micrometers [4].

In this section, we will create a solid model for the microgripper. The model will be used for simulation in Section 13.3 to assess the gripping forces on the bead under the actuation of the SMA actuator.

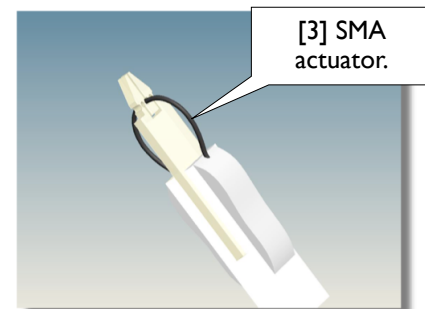
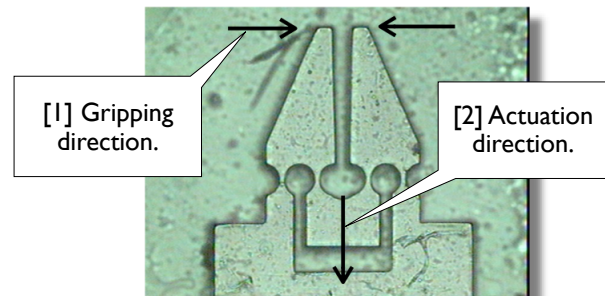
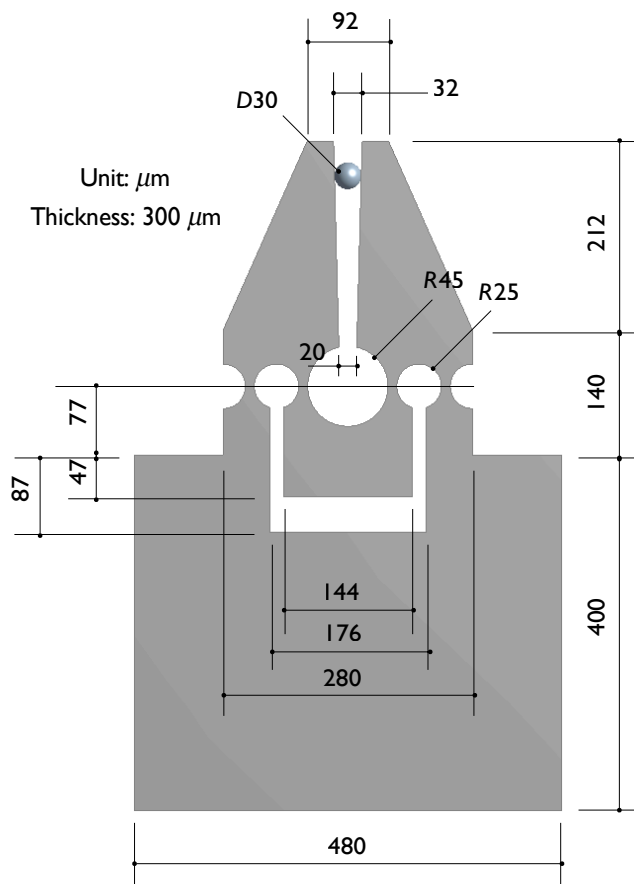

## 2.6-2 Create Half of the Model

Launch **Workbench**. Create a **Geometry** system. Save the project as **Microgripper**. Start up **DesignModeler**. Select **Micrometer** as the length unit.

Draw a sketch on **XYPlane** [1]. Trim away unwanted segments [2]. Note that we drew half of the model, due to the symmetry. Extrude the sketch 150  $\mu\text{m}$  both sides symmetrically (total depth is 300  $\mu\text{m}$ ) [3]. We now have a half of the gripper [4].

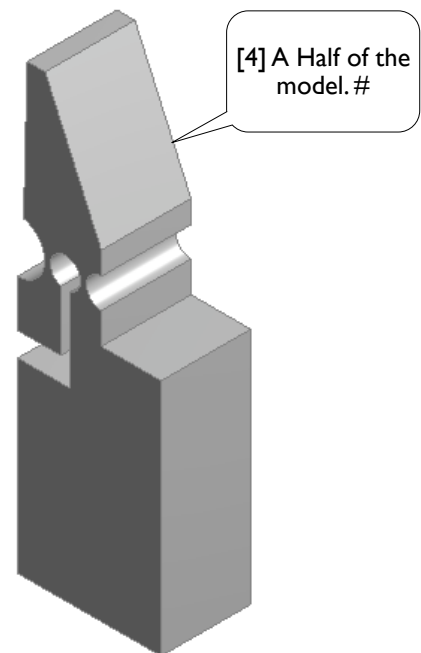
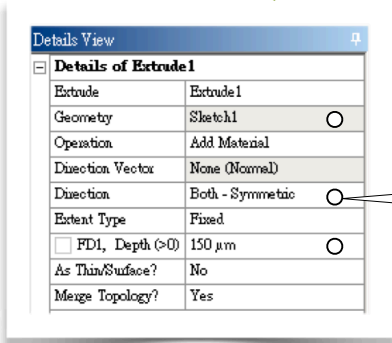
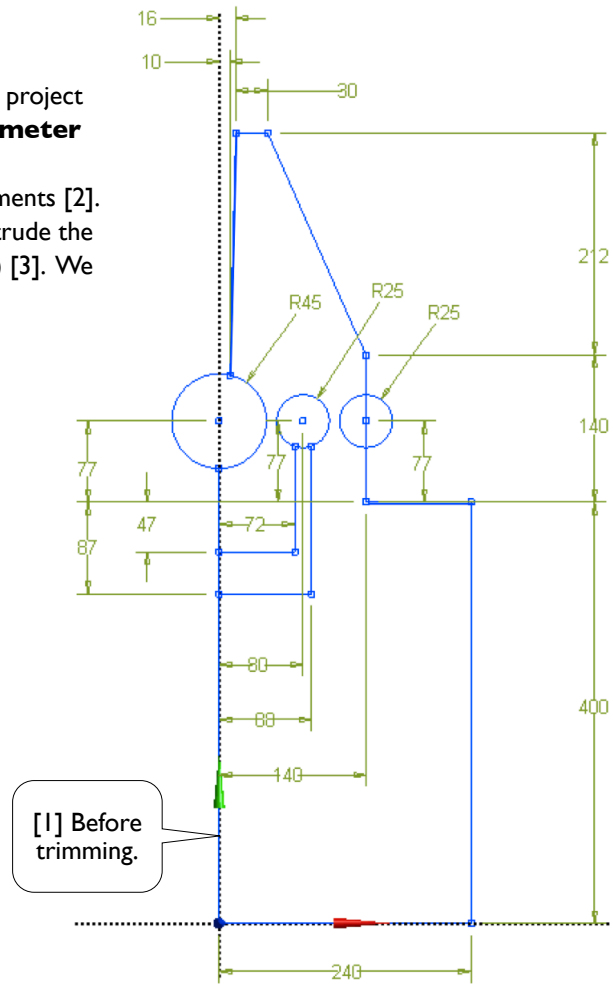
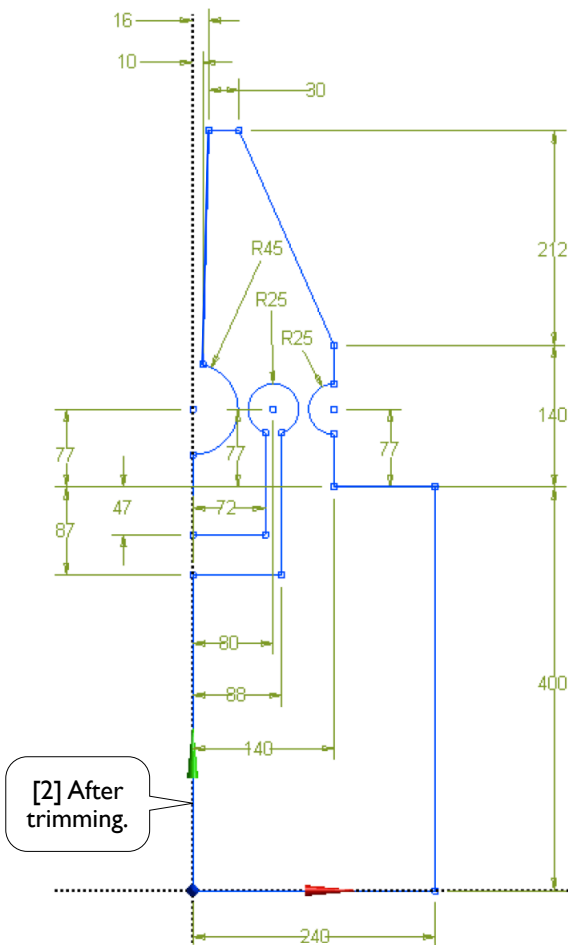

## 2.6-3 Mirror Copy the Solid Body

[1] Pull-down-select **Create/Body Transformation/Mirror**.

[2] In the graphics window, select the solid body and click **Apply**.

[3] Click this yellow area to bring up the **Apply/Cancel** buttons.

[4] In **Tree Outline**, select **YZPlane** and click **Apply**.

Details of Mirror1	
Mirror	Mirror1
Preserve Bodies?	Yes
Mirror Plane	Not selected
Bodies	1

Details of Mirror1	
Mirror	Mirror1
Preserve Bodies?	Yes
Mirror Plane	YZPlane
Bodies	1

[5] Click **Generate.#**

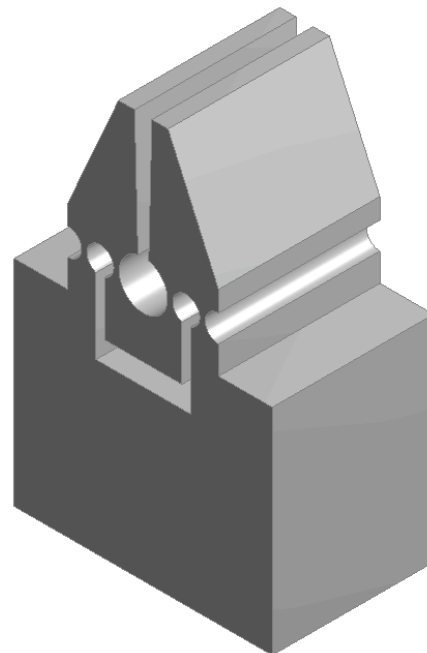



## 2.6-4 Create the Bead

Create a new sketch on **XYPlane** as shown in [1, 2] and draw a semicircle as shown in [3-6]. Revolve the sketch 360° about the Y-axis to create the bead [7]. Note that the two bodies are treated as two parts [8]. Rename the two bodies as **Gripper** and **Bead** respectively [9].

[1] Select **XYPlane**.

[2] Click **New Sketch**.

[3] The semicircle can be created by creating a full circle and then trimming it using the axis.

[4] Close the sketch by drawing a vertical line.

[5] Specify the radius (15  $\mu\text{m}$ ).

[6] Impose a **Tangent** constraint between the semicircle and the sloping line.

[7] **Revolve** about the Y-axis to create the steel bead.

[8] The two bodies are treated as two parts (see [9]).

[9] Right-click to rename each body like this. #

Revolve

A: Geometry

- XYPlane
- Sketch1
- Sketch2
- ZXPlane
- YZPlane
- Extrude1
- Sketch1
- Mirror1
- Revolve1
- Sketch2
- 2 Parts, 2 Bodies
  - Gripper
  - Bead

## Wrap Up

Close **DesignModeler**, save the project and exit **Workbench**. We will resume this project in Section 13.3.

## References

1. Chang, R.J., Lin, Y.C., Shiu, C.C., and Hsieh, Y.T., "Development of SMA-Actuated Microgripper in Micro Assembly Applications," IECON, IEEE, Taiwan, 2007.
2. Shih, P.W., *Applications of SMA on Driving Micro-gripper*, MS Thesis, NCKU, ME, Taiwan, 2005.

# Section 2.7

## Review

---

### 2.7-1 Keywords

Choose a letter for each keyword from the list of descriptions

- |                          |                          |
|--------------------------|--------------------------|
| 1. ( ) Auto Constraints  | 8. ( ) Object            |
| 2. ( ) Branch            | 9. ( ) Paste Handle      |
| 3. ( ) Constraint Status | 10. ( ) Sketching Mode   |
| 4. ( ) Context Menu      | 11. ( ) Sketching Plane  |
| 5. ( ) Edge              | 12. ( ) Sketch           |
| 6. ( ) Modeling Mode     | 13. ( ) Selection Filter |
| 7. ( ) Model Tree        |                          |

### Answers:

1. ( J ) 2. ( G ) 3. ( M ) 4. ( I ) 5. ( D ) 6. ( B ) 7. ( F ) 8. ( H )  
9. ( L ) 10. ( A ) 11. ( C ) 12. ( E ) 13. ( K )

### List of Descriptions

- ( A ) An environment under **DesignModeler**, its function to draw sketches on a plane.
- ( B ) An environment under **DesignModeler**, its function to create 3D or 2D bodies.
- ( C ) The plane on which a sketch is created. Each sketch must be associated with a plane; each plane may have multiple sketches on it. Usage of planes is not limited for storing sketches.
- ( D ) In **Sketching** mode, an edge may be a (straight) line or a curve. A curve may be a circle, ellipse, arc, or spline.
- ( E ) A sketch consists of points and edges. Dimensions and constraints may be imposed on these entities.
- ( F ) A model tree is the structured representation of a geometry and displayed on **Tree Outline** in **DesignModeler**. A model tree consists of features and a part branch, in which their order is important. The parts are the only objects exported to **Mechanical**.

- ( G ) A branch is an object of a model tree and consists of one or more objects under itself.
- ( H ) A leaf or branch of a model tree is called an object.
- ( I ) The menu that pops up when you right-click your mouse. The contents of the menu depend on what you click.
- ( J ) While drawing in **Sketching** mode, by default, **DesignModeler** attempts to detect the user's intentions and tries to automatically impose constraints on points or edges. Detection is performed over entities on the active plane, not just active sketch. **Auto Constraints** can be switched on/off in the **Constraints** toolbox.
- ( K ) A selection filter filters one type of geometric entities. When a selection filter is turned on/off, the corresponding type of entities become selectable/unselectable. In **Sketching** mode, there are two selection filters, namely points and edges filters. Along with these two filters, face and body selection filters are available in **Modeling** mode.
- ( L ) A reference point used in a copy/paste operation. The point is defined during copying and will coincide with a specified location when pasting.
- ( M ) In **Sketching** mode, entities are color coded to indicate their constraint status: greenish-blue for under-constrained; blue and black for well constrained (i.e., fixed in the space); red for over-constrained; gray for inconsistent.

## 2.7-2 Additional Workbench Exercises

### Create Models with Your Own Way

After so many exercises, you should be able to figure out many alternative ways of creating the geometric models in this chapter. Try to re-create the models in this chapter using your own way.