

# Tutorial Guide to AutoCAD® 2018

## 2D Drawing, 3D Modeling

- Covers 2D drawing and 3D modeling
- Uses step-by-step tutorials and is written for novice users
- Organization that parallels an introductory engineering course
- Mechanical, electrical, civil, and architectural based end of chapter problems
- Prepares you for the AutoCAD Certification Exam

### Description

Tutorial Guide to AutoCAD 2018 provides a step-by-step introduction to AutoCAD with commands presented in the context of each tutorial. In fifteen clear and comprehensive chapters, author Shawna Lockhart guides readers through all the important commands and techniques in AutoCAD 2018, from 2D drawing to solid modeling and finally finishing with rendering. In each lesson, the author provides step-by-step instructions with frequent illustrations showing exactly what appears on the AutoCAD screen. Later, individual steps are no longer provided, and readers are asked to apply what they've learned by completing sequences on their own. A carefully developed pedagogy reinforces this cumulative-learning approach and supports readers in becoming skilled AutoCAD users.

Tutorial Guide to AutoCAD 2018 begins with three Getting Started chapters that include information to get readers of all levels prepared for the tutorials. The author includes tips that offer suggestions and warnings as you progress through the tutorials. Key Terms and Key Commands are listed at the end of each chapter to recap important topics and commands learned in each tutorial. Also, a glossary of terms and Commands Summary list the key commands used in the tutorials. Each chapter concludes with end of chapter problems providing challenges to a range of abilities in mechanical, electrical, and civil engineering as well as architectural problems.

### Table of Contents

Getting Started: Preparing for the Tutorials
Getting Started: AutoCAD Basics
Getting Started: Studying for the AutoCAD Certification Exam
1. Introduction to AutoCAD
2. Basic Construction Techniques
3. Basic Editing and Plotting Techniques
4. Geometric Constructions
5. Template Drawings and More Plotting
6. 2D Orthographic Drawings
7. Dimensioning
8. Advanced Dimensioning
9. Section and Auxiliary Views
10. Blocks, DesignCenter, and Tool Palettes
11. Introduction to Solid and Surface Modeling
12. Changing and Plotting Solid Models
13. Creating Assembly Drawings from Solid Models
14. Solid Modeling for Section and Auxiliary Views
15. Rendering
Glossary
Appendix A: AutoCAD Command Summary
Index



Better Textbooks. Lower Prices.  
[www.SDCpublications.com](http://www.SDCpublications.com)

SUGGESTED PRICE  
Retail \$78  
School Bookstores \$49

READER LEVEL  
Beginner to Intermediate

ISBN: 978-1-63057-120-7



Visit the following websites to learn more about this book:



[amazon.com](https://www.amazon.com)

[Google books](https://books.google.com)

[BARNES & NOBLE](https://www.barnesandnoble.com)

# BASIC CONSTRUCTION TECHNIQUES

## 2

### Introduction

You usually create drawings by combining and modifying several different basic *primitive* shapes, such as lines, circles, and arcs, to create more complex shapes. This tutorial will help you learn how to draw shapes. Keep in mind that one of the advantages of using CAD over drawing on paper is that you are creating an accurate model of the drawing geometry. In Tutorial 3, you will learn to list information from the drawing database. Information extracted from the drawing is accurate only if you create the drawing accurately in the first place.

### Starting

Before you begin, **launch AutoCAD 2018**.

### Opening an Existing Drawing

This tutorial shows you how to add arcs and circles to the subdivision drawing provided with the datafiles that came with this guide. In Tutorial 3 you will finish the subdivision drawing so that the final drawing will look like Figure 2.1.

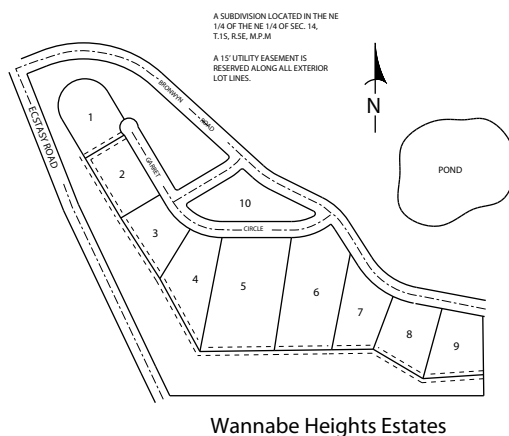

**Figure 2.1**

To open an existing drawing, use the Application icon, Open selection or click the button that looks like an open folder from the Quick Access toolbar.

 **Click: Open button**

The Select File dialog box appears on your screen. Use the center portion, which shows the default directory and drive, to select the location where your datafiles have been stored. You should have already created a folder called *datafile2018*, and copied all the datafiles for this book into it. If you have not done so, you may want to review the Getting

### Objectives

When you have completed this tutorial, you will be able to

1. Open existing drawings.
2. Work with new and existing layers.
3. Draw, using the Arc and Circle commands.
4. Set and use running Object snaps.
5. Change the display, using Zoom and Pan.
6. Use Dynamic View.
7. Draw ellipses.

**Tip:** It is easy to download the datafiles. Use your browser to navigate to [www.sdcpublishations.com/Authors/Shawna-Lockhart](http://www.sdcpublishations.com/Authors/Shawna-Lockhart). From there select the text you are using. Find and click the Download button on the page for your text.

**Tip:** Use the buttons at the left of the dialog box to show the History (recently used files), My Documents folder contents, or Favorites you have added. To add a favorite, find the folder and then right-click the Favorites button. Pick Add Current Folder from the pop-up menu that appears. To add a folder as a button, pick Tools, Add Current Folder to Places.

You can also use Autodesk 360 to display documents you have stored on a remote internet server sometimes called “the cloud.” This allows you to view your files from anywhere you can connect to the internet. You can also browse your computer’s desktop and Autodesk’s Buzzsaw area from these sidebar icons.

Started chapters. If the correct folder is not showing in the Look In box, use the Up One Level icon or expand the choices by clicking on the downward arrow for the Look In box. Use the scroll bars if necessary to scroll down the list of directories and open the appropriate one so the files appear in the dialog box as in Figure 2.2. Scroll down the list of files until you see the file named *subdivis.dwg*. When you select a file, a preview of the file appears in the box to the right. (Older files may not show a preview.)

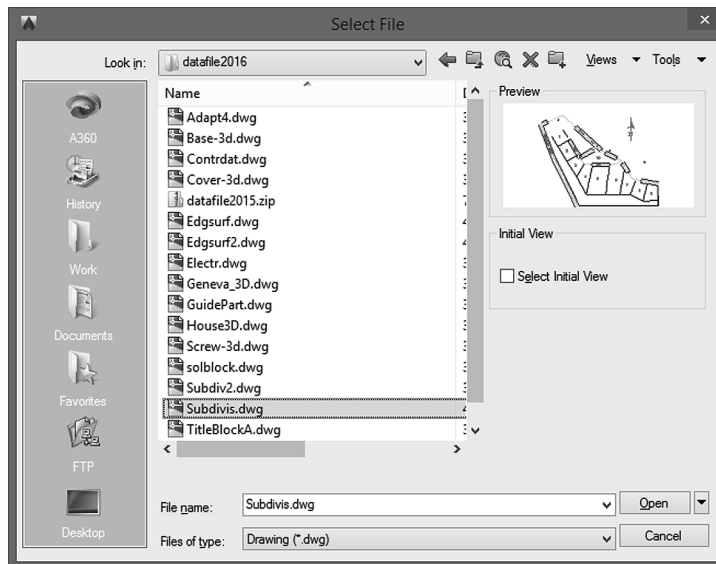

**Figure 2.2**

Menu choices at the top right of the Select File dialog box let you select different views to be displayed in the file list and other useful tools, such as a Find selection to search for files.

*Click: **Tools, Find***

*Type: **subdivis** (in the Named area)*

*Click: **Find Now button** (from upper right of dialog box)*

The Find dialog box displays the location for the file named *Subdivis.dwg*, as shown in Figure 2.3. You can type in a portion of the name to match if you cannot remember the entire name or click the Date Modified tab if you want to search by date and time the file was created.

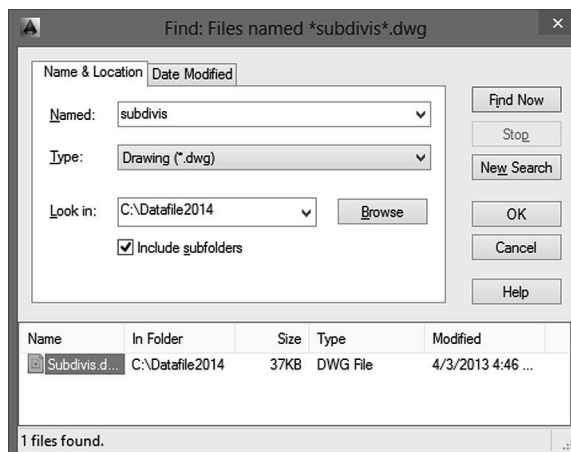

**Figure 2.3**

Double-click: **Subdivis.dwg** ( to select it from the list at the bottom)

You return to the Select File dialog box.

Click: **Open**

Double-click: in the center of the screen to zoom to the drawing extents

When you have opened the file, it appears on your screen, as shown in Figure 2.4. It opens with its own defaults for Grid, Snap, and other features. These settings are saved in the drawing file.



Figure 2.4

## Saving as a New File

The Save As command allows you to save your drawing to a new file name and/or different drive or folder. You can select this command from the Application icon or from the Quick Access toolbar.

 Click: **Save As button**

The Save Drawing As dialog box appears similar to Figure 2.5.

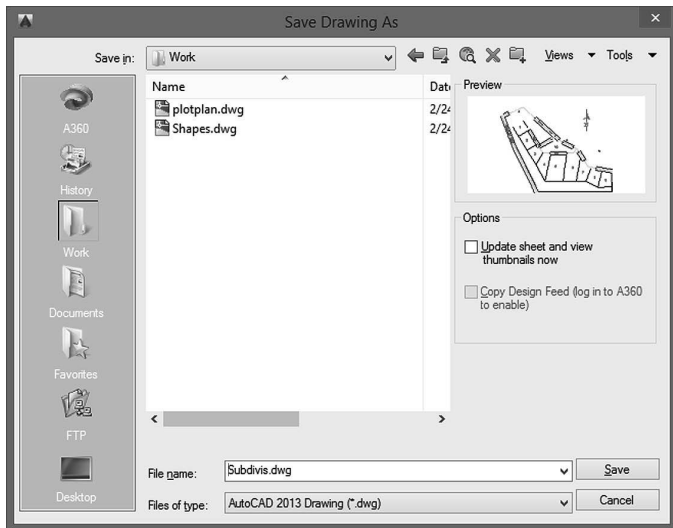

Figure 2.5

**Tip:** Don't use the Save command because that will save your changes into the original datafile.

**Tip:** Notice that if you have set up an account, you can use the A360 selection to save your files to storage in the “cloud.”

**Warning:** If you save a file with the same name as one already in the directory, you will see a message the file “already exists. Do you want to replace it?” Choose No unless you want to replace the file.

On your own, select the drive and folder *work* and specify the name for your drawing, *subdivis.dwg*.

In this case, the new file name is the same as the previous file name, but the folder is different. This creates a new copy of drawing *subdivis.dwg* saved in the folder named *work*.

The original *subdivis.dwg* remains unchanged on your drive. When you use the Save As command and specify a new file name, the software sets the newly saved file as current.

## Using Layers

You can organize drawing information on different layers. Think of a *layer* as a transparent drawing sheet that you place over the drawing and that you can remove at will. The coordinate system remains the same from one layer to another, so graphical objects on separate layers remain aligned. You can create a virtually unlimited number of layers within the same drawing. The Layer command allows control of the color and linetype associated with a given layer. Using layers allows you to overlay a base drawing with several different levels of detail (such as wiring or plumbing schematics over the base plan for a building).

By using layers, you can also control which portions of a drawing are plotted, or remove dimensions or text from a drawing to make it easier to add or change objects. You can also lock layers, making them inaccessible but still visible on the screen. You can't change anything on a locked layer until you unlock it.

## Current Layer

The *current layer* is the layer you are working on. Any new objects you draw are added to the current layer. The default current layer is layer 0. If you do not create and use other layers, your drawing will be created on layer 0. You used this layer when drawing the plot plan in Tutorial 1. Layer 0 is a special layer provided in the AutoCAD program.

You cannot rename or delete layer 0 from the list of layers. Layer 0 has special properties when used with the Block and Insert commands, which are covered in Tutorial 10.

Layer POINTS is the current layer in *mysubdivis.dwg*. There can be only one current layer at a time. The name of the current layer appears on the Layer toolbar.

## Controlling Layers

The Layer Control feature on the Layers panel on the Home tab of the ribbon is an easy way to control the visibility of existing layers in your drawing. You will learn more about creating and using layers in this tutorial. For now, you will use layers that have already been created for you.

*Click: on layer name POINTS from the Layers panel*

The list of available layers pulls down, as shown in Figure 2.6. Notice the special layer 0 displayed near the top of the list.

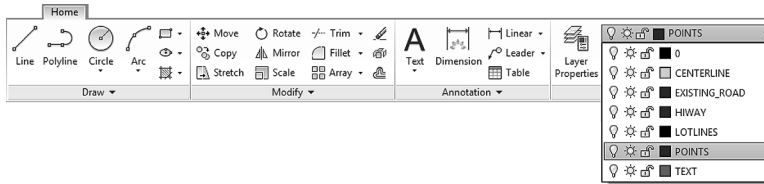

**Figure 2.6**

*Click: on the layer name CENTERLINE from the Layer Control list*

It becomes the current layer shown on the toolbar. Any new objects will be created on this layer until you select a different current layer. The Layer Control now should look like Figure 2.7, showing the layer name CENTERLINE.

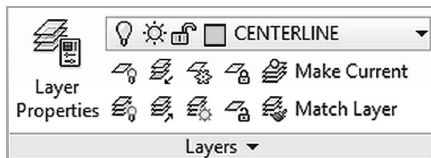

**Figure 2.7**

Use the Line command you learned in Tutorial 1 to draw a line off to the side of the subdivision drawing.

Note that it is green and has a centerline linetype (long dash, short dash, long dash). The line you drew is on Layer CENTERLINE.

Erase or Undo the line on your own.

## Controlling Colors

Each layer has a color associated with it. Using different colors for different layers helps you visually distinguish different information in the drawing. An object's color also may control appearance during printing.

There are two different ways of selecting the color for objects on your screen. The best way is usually to set the layer color and draw the objects on the appropriate layer. This method keeps your drawing organized. The other method is to use the Color Control feature on the Properties panel. To select the Color Control pull-down feature,

*Click: ByLayer from the Properties panel to pull down the Color Control*



**Figure 2.8**

Note that the standard colors (yellow, red, green, blue, etc.) are shown. You can also choose More Colors to view the full color palette.

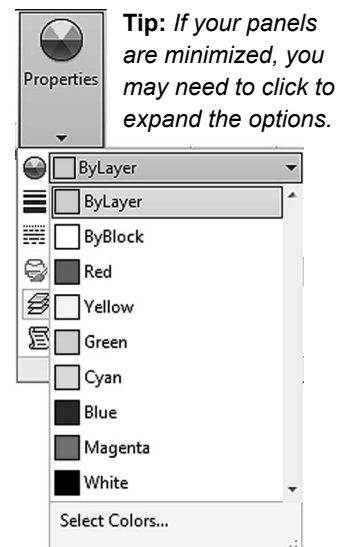

**Tip:** On a black background, color 7 used for layer 0 appears as white; on a white background it appears black.

*Click: **More Colors***

The Select Color dialog box shown in Figure 2.9 appears on your screen, giving you a full range of colors from which to choose.

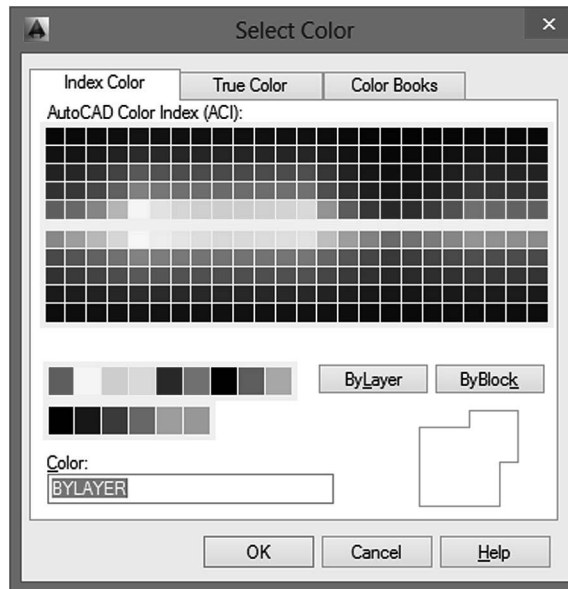

**Figure 2.9**

The three tabs of the Select Color dialog box allow you to choose among different methods to determine the color for your drawing entities. The True Color tab allows you to set color to either RGB, which stands for Red, Green, Blue, the primary colors of light, or HSL, which stands for the Hue, Saturation, and Luminance of the color. The Color Books tab lets you select from among different standard ink manufacturer's predefined colors so that you can match print colors very closely to the colors you choose on your screen. In this text you will use Index Color (AutoCAD Color Index) as the method for selecting color.

*Make sure the **Index Color** tab is selected.*

The default option for the Color (and also for the Linetype) command is BYLAYER. It's the best selection because, when you draw a line, the color and linetype will be those of the current layer. Otherwise, the color in your drawing can become very confusing. You will click Cancel to exit the Select Color dialog box without making any changes. The colors for your new objects will continue to be determined by the layer on which they are created. Layers can have associated linetypes, as well as colors, as Layer CENTERLINE does.

*Click: **Cancel***

## Layer Visibility

One of the advantages of using layers in the drawing is that you can choose not to display selected layers. That way, if you want to create projection lines or even notes about the drawing, you can draw them on a layer that you will later turn off, so that it isn't displayed or printed. Or you may want to create a complex drawing with many layers, such



as a building plan that contains the electrical plan on one layer and the mechanical plan on another, along with separate layers for the walls, windows, and so on. You can store all the information in a single drawing, and then plot different combinations of layers to create the electrical layout, first-floor plan, and any other combination you want.

Next you will use the Layer Control to lock, freeze, and turn off some of the layers in this drawing.

*Click: **on CENTERLINE** to show the list of layers*

The list of layers pulls down. Refer to Figure 2.10 as you make the following selections.

*Click: **the On/Off icon**, which looks like a lightbulb, to the left of Layer EXISTING\_ROAD*

*Click: **any blank area of the screen away from the Layer list** to return to the drawing*

Note that the blue roadway lines have been turned off so that they no longer appear. Invisible (off) layers are not printed or plotted, but objects on these layers are still part of the drawing.

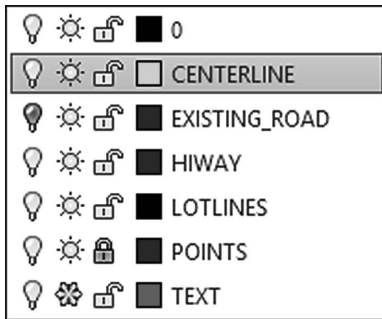

Figure 2.10 Layer Control

## Freezing Layers

Freezing a layer is similar to turning it off. You use the *freeze* option not only to make the layer disappear from the display, but also to cause it to be skipped when the drawing is regenerated. This feature can noticeably improve the speed with which the software regenerates a large drawing. You should not freeze the current layer because that would create a situation where you would be drawing objects that you couldn't see on the screen. The icon for freezing and thawing layers looks like a snowflake when frozen and a shining sun when thawed.

*Click: to **expand the Layer Control list***

*Click: **the Freeze/Thaw icon** to the left of Layer TEXT*

*Click: **any blank area in the graphics window** to return to the drawing*

Layer TEXT is still on, but it is frozen and therefore invisible. A layer can both be turned off and frozen; the effect is similar. You should either freeze a layer or turn it off, but there is no point in doing both. Your screen should now be similar to Figure 2.11.

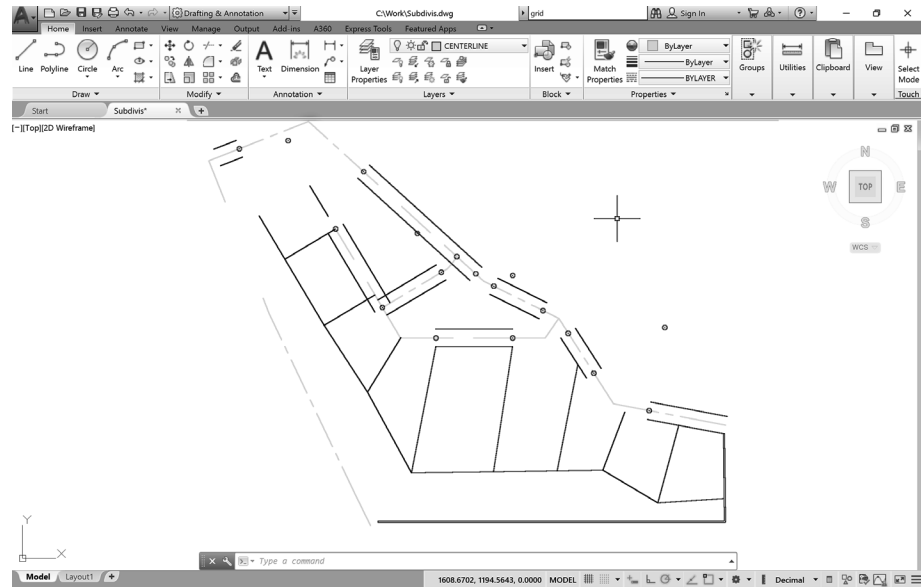

Figure 2.11

## Locking Layers

You can see a *locked layer* on the screen, and you can add new objects to it. However, you can't make changes to the new or old objects on that layer. This is useful when you need the layer for reference but do not want to change it. For example, you might want to move several items so that they line up with an object on the locked layer but prevent anything on the locked layer from moving. You will lock layer POINTS so that you cannot accidentally change the points already on the layer.

*Click: the Lock/Unlock icon to the left of Layer POINTS*

Layer CENTERLINE should still be the current layer. (If for some reason it is not the current layer, set it current at this time.) Layer TEXT is frozen and does not appear. Layer EXISTING\_ROAD is turned off and does not appear. Layer POINTS is locked so that you can see and add to it, but not change it.

On your own, try erasing one of the circled points in the drawing.

A message appears, stating that the object is on a locked layer. The object won't be erased.

## Making Object's Layer Current

The Make Current button is located above the Layer Control pull-down (Figure 2.11). This command lets you select an object and then click on the icon to make that object's layer the current layer.

*Click: a black lot line (white if your background color is black) representing a lot boundary*

Note that the Layer Control now shows LOTLINES, the layer of the line you selected. This name is only temporary, for if you drew a new line, the layer name changes back to the current layer (CENTERLINE). This is useful when you are unsure which layer a particular object is on.

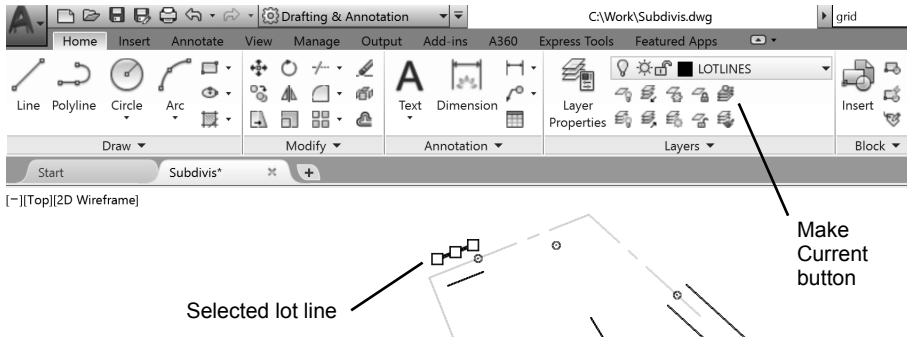

Figure 2.12

Next you will use the Make Current button to set LOTLINES as the current layer.

**Make sure a black lot line is still highlighted**



**Click: Make Object's Layer Current icon**

The current layer is changed to LOTLINES, and any new objects will be added to this layer. In the command prompt is the message: LOTLINES is now the current layer.

Now you will change the current layer back to CENTERLINE by using the Layer Previous button. If you are not sure which button to select, hover your mouse over the buttons to show the tooltips.



**Click: to expand the Layer panel (down arrow near panel name)**

**Click: Layer Previous button**

Layer CENTERLINE returns as the current layer.

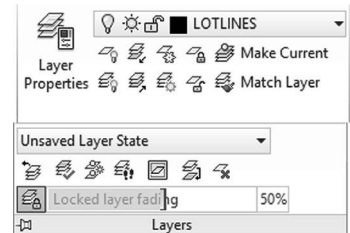

## Using Layer

The Layer command lets you create new layers and control the color and linetype associated with a layer. You can also use Layer to control which layers are visible or plotted at any one time and to set the current layer. Remember, only one layer at a time can be current. New objects are created on the current layer. Use the Layer Properties Manager icon from the Layer panel to create new layers and set their properties. (Its command alias is LA.)



**Click: Layer Properties Manager button**

The Layer Properties Manager appears on the screen, showing the list of existing layers (Figure 2.13).

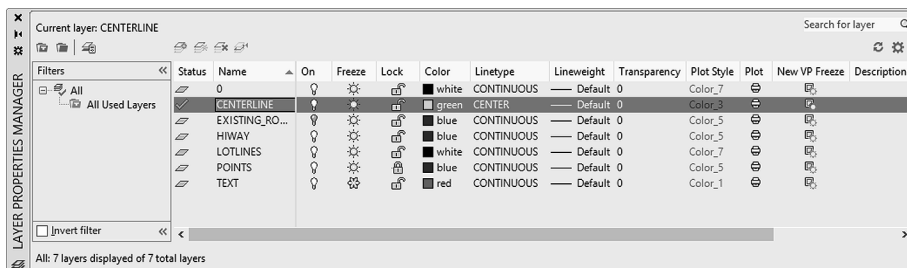

Figure 2.13

**Tip:** You can resize the Layer Properties Manager by dragging on its corners.

Notice that the layers you earlier turned off, locked, or froze are identified with those icons. Next you will create a layer named EASEMENTS which you will use later in Tutorial 3. It will have a hidden linetype and the color cyan (a light blue shade).



**Click: *New Layer icon*** (located near the top of the dialog box)

A new layer appears with the default name Layer1, which should be highlighted as shown in Figure 2.14.

**Tip:** You can right-click on a heading in the Layer Properties Manager, and select Maximize All Columns from the pop-up menu that appears.

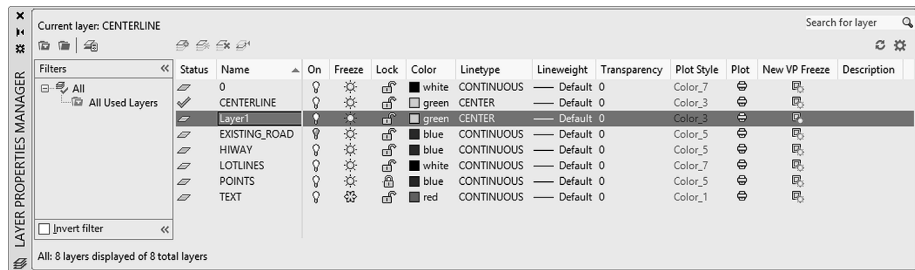

**Figure 2.14**

By default it has the same properties as the currently selected layer (CENTERLINE). You will change the layer name, color and linetype for the new layer next.

Layer names can be as long as 255 characters. Layer names can contain almost any characters, except for restricted operating system characters like comma (,) and others like <>/'?:\*|'=. Letters, numbers, spaces, and the characters dollar sign (\$), period (.), number sign (#), underscore (\_), and hyphen (-) are valid. While Layer1 is still highlighted,

**Type: *EASEMENTS [Enter]***

Next, set the color for layer EASEMENTS. To the right of the layer names are the various layer controls mentioned previously. Each column title is labeled with the name of the function: On (light bulb), Freeze (sun), Lock/Unlock (lock), Color (small color box), Linetype, Lineweight, Plot Style, Plot, and Description. You can resize these columns to show more or less of the names by dragging the line between the name headings.

To change the color for layer EASEMENTS,

**Click: *on the Color column box corresponding to layer EASEMENTS***

The Select Color dialog box containing color choices pops up on the screen as shown in Figure 2.15.

**Make sure that the Index Color tab is uppermost.**

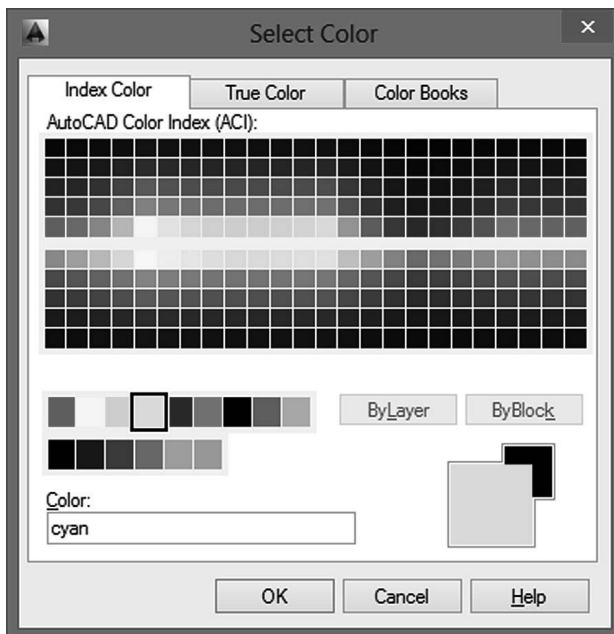

Figure 2.15

## Color in Layers

The Select Color dialog box allows you to specify the color for objects drawn on a layer. You will select the color cyan for the easement layer that you are creating. The color helps you visually distinguish linetypes and layers in drawings. You also use color to select the pen and pen width for your printer or plotter.

The Select Color dialog box has the choices `BYLAYER` and `BYBLOCK` on the right side. As you are specifying the color for layer `EASEMENTS` only, you can't select these choices, so they are shown grayed. Move the arrow cursor over the Standard Colors boxes, where cyan is the fourth color from the left.

*Click: cyan from the Standard Colors boxes to the left of the ByLayer button*

The name of the color that you have selected appears in the Color: box at the bottom of the screen. (If you select one of the standard colors, the name appears in the box; if you select one of the other 255 colors from the palette, the color number appears.)

*Click: OK*

Now the color for layer `EASEMENTS` is set to cyan. Check the listing of layer names and colors to verify that cyan has replaced green in the Color column to the right of the layer name `EASEMENTS`.

## Linetype in Layers

The linetype column allows you to set the linetype drawn for the layer. You will select the linetype **HIDDEN** for your layer named **EASEMENTS**.

**Click: on Center in the Linetype column across from layer EASEMENTS**

The Select Linetype dialog box appears on your screen.

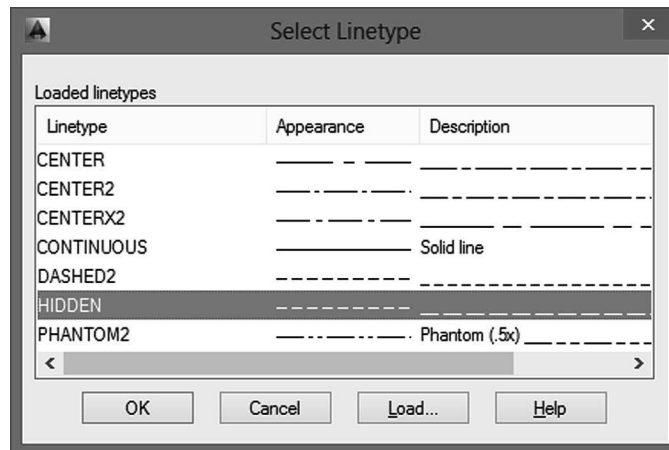

**Figure 2.16**

**Click: *HIDDEN* as shown in Figure 2.16**

**Click: *OK***

You return to the Layer Properties Manager. Layer **EASEMENTS** should have the properties set as shown in Figure 2.16.

**Click: *[X]* from its upper left to close the Layer Properties Manager**

**CENTERLINE** should still be the current layer on the Layer toolbar, showing a green square to the left of the layer name. You will use the **EASEMENTS** layer you created later in this tutorial.

Using layers to control the color and linetype of new objects that you create will work only if **BYLAYER** is active as the method for establishing object color, object linetype, and lineweight.

On your own, examine the Color Control, Linetype Control, and the Lineweight Control on the Properties panel. All three should be set to **BYLAYER**.

Now that you know the basics of using and creating layers, you will begin creating the curved sections of the road centerline for the subdivision. The straight-line sections that the curves are tangent to have been drawn to get you started.

## Using Object Snap

The object snap feature accurately selects locations based on existing objects in your drawing. When you click points from the screen without using object snaps, the resolution of your screen makes it impossible for you to select points with the accuracy stored in the drawing database. You have learned how to click accurately by snapping to a grid point. *Object snap* makes it possible for you to click points accurately on your drawing geometry by snapping to an object's center, endpoint, midpoint, and so on. Whenever prompted to select a point or location, you can use an object snap to help make an accurate selection. Without this command, locating two objects with respect to each other in correct and useful geometric form is virtually impossible. Object snap is one of the most important CAD tools. There are several different ways to access and use the Object Snaps.

 **Right-click: the Object Snap button on the Status bar**

The menu of Object Snap modes appears on your screen as shown in Figure 2.17.

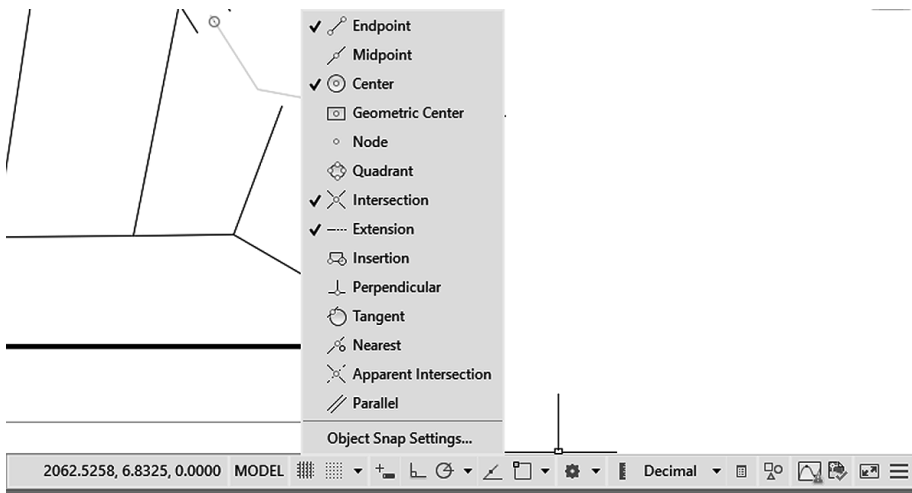

**Figure 2.17**

Object Snap can operate in two different ways. The first is called *override mode*. With this method, you select the object snap during a command. The object snap acts as a modifier within the command string to *target* the next point you select. You activate object snaps from within other commands by clicking the appropriate icon from the Object Snap toolbar. The object locations they select are indicated by small circles on the icons. When you activate an object snap in this manner, it is active for one click only. Remember, you can use this method only during a command that is prompting you to select points or objects.

A special feature is active when Object Snap is in use. It displays a marker and description (SnapTip) when the cursor is placed near or on a snap point. This feature helps you to determine what location on the object will be selected.

The second method for using Object Snap is called *running mode*. With this method, you turn on the object snap and leave it on before using

**Tip:** You can click the arrow to the right of the Object Snap button to expand the options.

**Tip:** You can also activate an object snap by typing the three-letter name any time you are prompted to enter points or select objects. Refer to the Command Summary for the three letter codes.

commands. When a running mode object snap is on, the marker box and SnapTip will appear during any future command when you are prompted for a point location, object selection, or other choice. The SnapTip will tell you which object snap location is being targeted.

*Click: **Object Snap Settings** from the menu (see Figure 2.17)*

The Drafting Settings dialog box you used to set the snap and grid appears on your screen. Notice it has many tabs: Snap and Grid, Polar Tracking, and Object Snap, and so on. Object Snap should be on top.

*Click: **Clear All** (to unselect any current modes)*

*Click: **Node***

A check appears in the box when it is selected, as shown in Figure 2.18. Node snaps to objects drawn with the AutoCAD Point command. The symbol next to the Node setting represents the AutoSnap marker shape that will appear in the drawing.

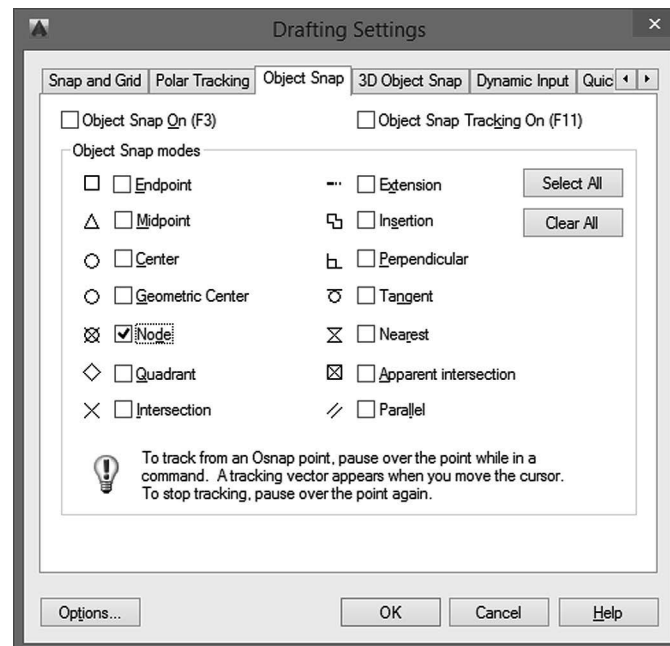

**Figure 2.18**

*Click: **Options** (from the lower left of the dialog box)*

The Options dialog box appears on your screen as shown in Figure 2.19. You can use it to change Marker size, color, and settings. You may want to make the Marker box smaller or larger, depending on your drawing's complexity and size.



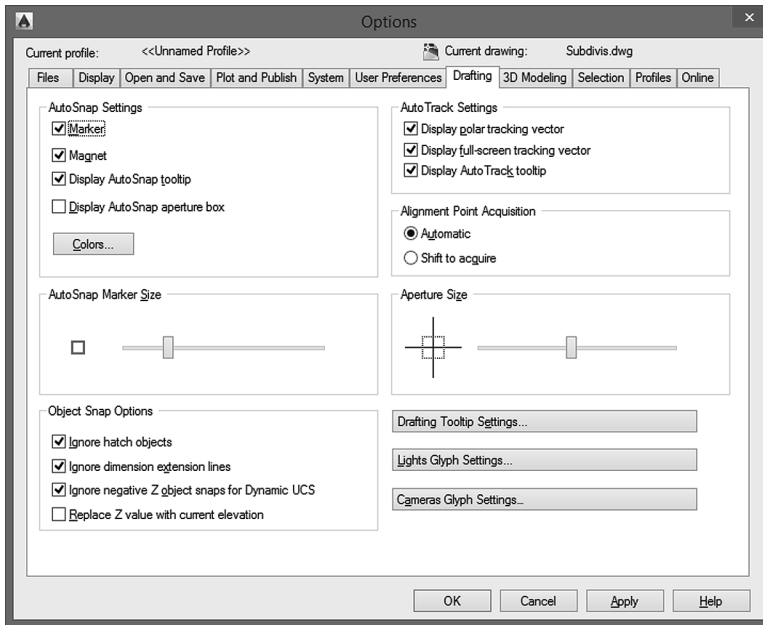

Figure 2.19

On your own, try using the slider to make the box smaller and then larger. Next, you may want to change the Marker color to a more noticeable color, such as red. When you have finished,

Click: **OK** (to exit the Options dialog box)

Click: **OK** (to exit the Drafting Settings dialog box)

Click: **Object Snap** button to turn it on, if it is not already on

On your own, click the small downward arrow to the right of the Object Snap button on the status bar to expand the options. Notice that now Node is checked and the other modes do not have check marks. You can also set the object snap modes quickly by checking or unchecking them from this list.

Make sure that **Ortho mode, Polar tracking, and Object snap tracking** are **off**.

Object Snap is a very useful tool and you will use it frequently throughout the rest of this guide. It can be very important to turn it on and off as needed. Notice that the Object Snap button on the Status bar is highlighted, meaning it is active. You may click the Object Snap button to toggle it on or off, similar to the Snap Mode and Grid buttons. Check your status bar to make sure that the Object Snap button is turned on (it appears highlighted).

Now you are ready to start creating arcs at accurate locations in the drawing. When you are prompted to select, look for the marker box on the crosshairs. When it's there, you know that Snap to Node is being used to select the points that were set previously in the drawing.

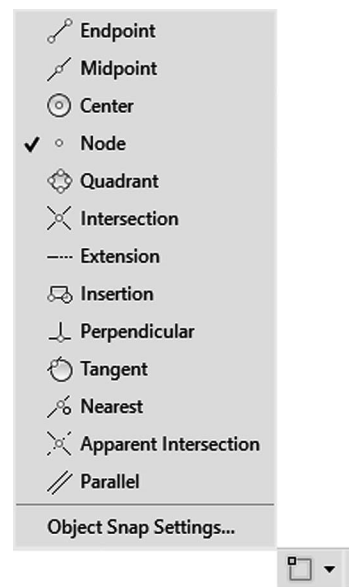

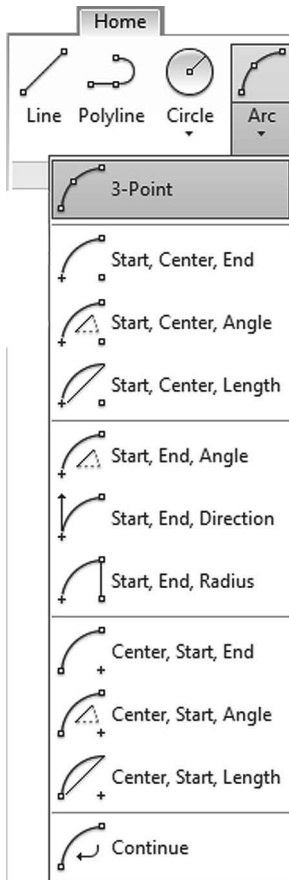

Figure 2.20

## Using Arc

The Arc command is on the ribbon Home tab, Draw panel, or you can type ARC at the command prompt. There are eleven different ways to create arcs. To see the options, click on the small triangle next to show the Arc flyout as shown in Figure 2.20.

Each Arc command option requires that you input point locations. The icons on the buttons help show you which points that option expects for input. You can define those point locations by manually typing in the coordinate values or locating the points with the cursor and clicking your mouse. For the exercises presented in this tutorial, follow the directions carefully so that your drawing will turn out correctly. Keep in mind that if you were designing the subdivision, you might not use all the command options demonstrated in this tutorial. When you are using AutoCAD software later for design, select the command options that are appropriate for the geometry in your drawing.

### Arc 3 Points

The 3 Points option of the Arc command draws an arc through three points that you specify. The dots located on the icon represent the three points of definition. This means that three point locations will be necessary for drawing that arc. Remember, to specify locations you can click them or type in absolute, relative, or polar coordinates. You will draw an arc using the 3 Points option. The Snap to Node running object snap will help you click the points drawn in the datafile.

 Click: **3 Point** button

Specify start point of arc or [Center]: **select point 1**, using the AutoSnap marker as shown in Figure 2.21

As can be seen in Figure 2.21, the AutoSnap marker for Node appears when the cursor is near a node point.

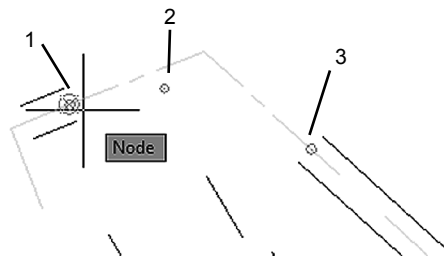

Figure 2.21

Now you will continue with selecting the points.

Specify second point of arc or [Center/End]: **select point 2**

The cursor enters drag mode, whereby you can see the arc move on the screen as you move the cursor. Many AutoCAD commands permit dynamic specification, or dragging, of the image on the screen.

Move the cursor around the screen to see how it affects the way the arc would be drawn. Recall your use of this feature to draw circles in Tutorial 1.

Specify end point of arc: **select point 3**

The third point defines the endpoint of the arc. The radius of the arc is calculated from the locations of the three points. Your drawing should now show the completed arc, as shown in the upper part of Figure 2.22.

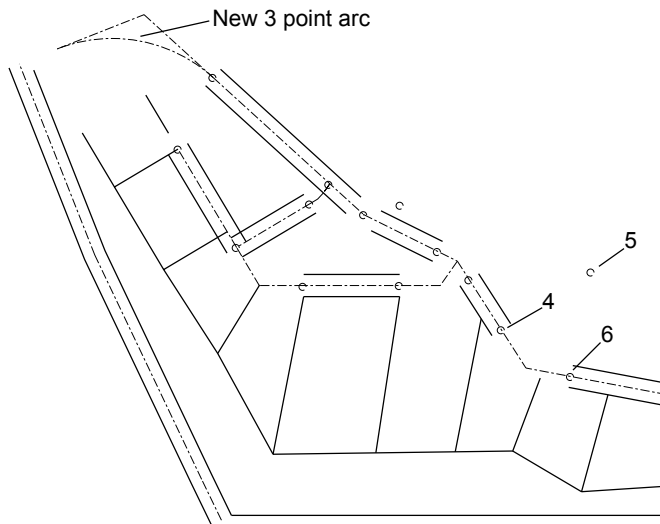

Figure 2.22

### Arc Start, Center, End

Next, you will draw an arc by specifying the start, center, and endpoints. Figure 2.22 shows the points used to create this arc.



Click: **Start, Center, End** button from the Arc flyout

Specify start point of arc or [Center]: **select point 4 as the start point**

Specify center point of arc: **select point 5 to act as the arc's center**

Specify end point of arc or [Angle/chord Length]: **select point 6 to end the arc**

The arc is drawn counterclockwise from the start point. Notice that now Start, Center, End is the top button on the Arc flyout. When you are using a flyout, the last item you clicked appears as the top flyout button, so options you use frequently take only one click.

Figure 2.22 shows the point locations needed to draw a *concave arc*. If the start point were located where the endpoint is, a *convex arc* outside the centerlines would have been drawn. When you have added the arc correctly, your arc should look like that in the lower part of Figure 2.23.

On your own, try drawing another arc with the Arc Start, Center, End option, this time clicking point 6 first, then the center, and then point 4.

Note that this arc is drawn counterclockwise, resulting in a convex arc.

Undo this backward arc by typing U [Enter] at the command prompt.

**Tip:** Pressing the space bar or [Enter] key to restart the arc command uses Arc in a more general way, where you must select the command options by clicking on or typing in the option letter(s).

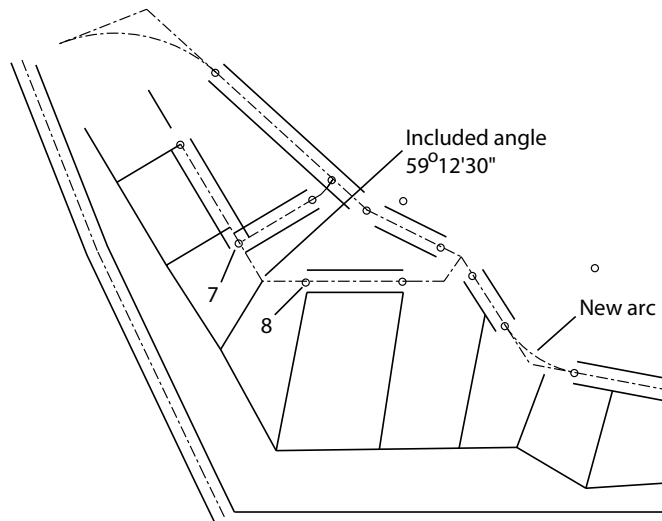

Figure 2.23

### Arc Start, End, Angle

Arc Start, End, Angle draws an arc through the selected start and endpoints by using the included angle you specify. Next, draw an arc with the Start, End, Angle option, referring to Figure 2.23. This time you will use dynamic entry.

Click: **to turn on Dynamic Input** from the Status Bar



Click: **Start, End, Angle** button from the Arc flyout

Specify start point of arc or [Center]: **select point 7**

Specify end point of arc: **select point 8**

Specify included angle: **59d12'30" [Enter]**

The arc is defined by the *included angular value* (often called the *delta angle* in survey drawings) from the start point to the end point. Positive angular values are measured counterclockwise. Negative angular values are measured clockwise. (Type d for the degree symbol when typing in surveyor angles. Use the single quote and double quote for minutes and seconds.)

### Arc Start, Center, Length

Arc Start, Center, Length draws an arc specified by the start and center points of the arc and the chord length. The chord length is the straight-line distance from the start point of the arc to the endpoint of the arc. You can enter negative values for the chord length to draw an arc in the opposite direction. Figure 2.24 shows a diagram describing the geometry of this type of arc.

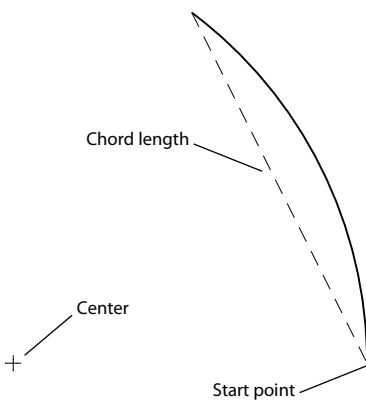

Figure 2.24

You will draw the next arc by using Arc Start, Center, Length.  
 Figure 2.25 shows the dynamic entry to use for the chord length.

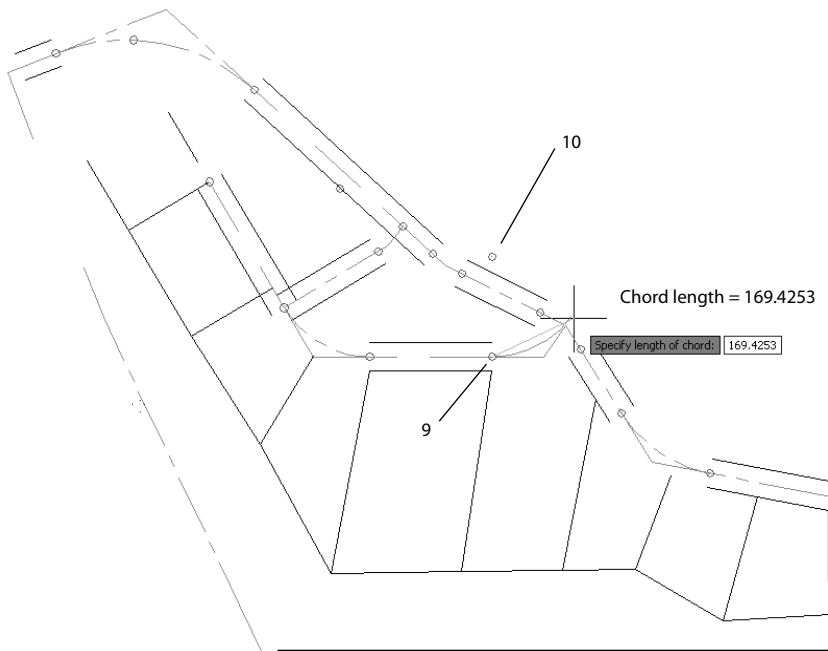

Figure 2.25



Click: **Start, Center, Length** button from the Arc flyout

Specify start point of arc or [Center]: **select point 9**

Specify center point of arc: **select point 10**

Specify length of chord: **169.4253 [Enter]**

Your new arc should look like the one shown in Figure 2.26.

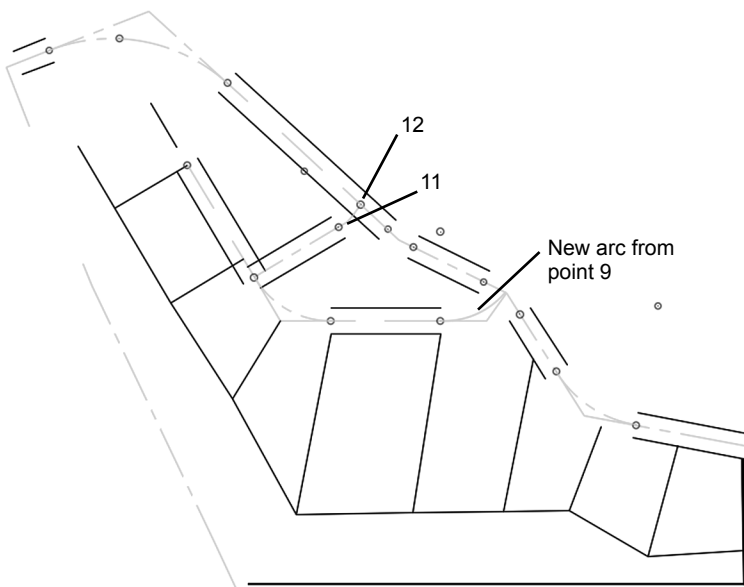
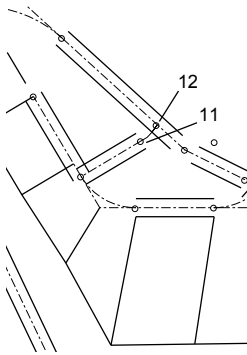

Figure 2.26



## Arc Start, End, Radius

Draw the next arc using Start, End, Radius. The locations of the start and end points are at 11 and 12.

Click: **Start, End, Radius button** from the Arc flyout

Specify start point of arc or [Center]: **select point 11**

Specify end point of arc: **select point 12**

Specify radius of arc: **154.87 [Enter]**

Your drawing should be similar to that in Figure 2.27.

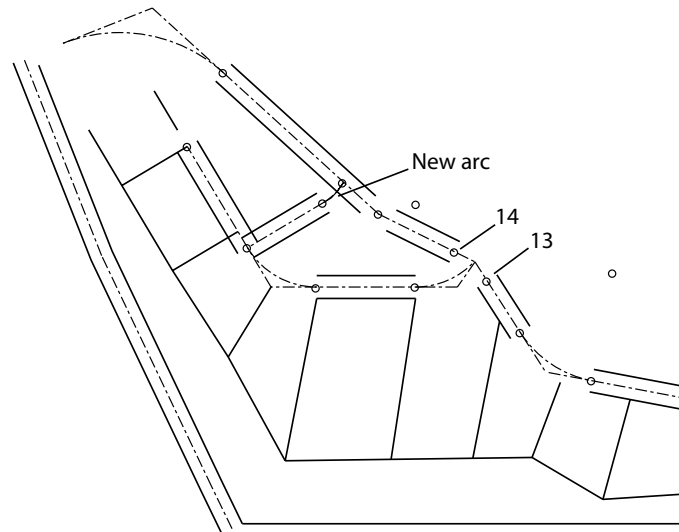

Figure 2.27

## Continuing an Arc

Arc Continue allows you to join an arc to a previously drawn arc or line. You will give it a try off to the side of the subdivision drawing and then erase or undo it, as it is not a part of the drawing. To draw an arc that is the continuation of an existing line,

Click: **Line button**

On your own, draw a line anywhere on your screen.

Click: **Continue** from the Draw panel, Arc flyout

The last point of the line becomes the first point for the arc. The cursor is in drag mode, and an arc appears from the end of the line. You are prompted for an endpoint.

Specify end point of arc: **select an endpoint**

Next you will use Arc Start, Center, End to draw another arc. Then you will continue an arc from the endpoint of that arc.

Click: **Start, Center, End** from the Draw panel, Arc flyout

Specify start point of arc or [Center]: **select a start point**

Specify center point of arc: **select a center point**

Specify end point of arc or [Angle/chord Length]: **select an endpoint**

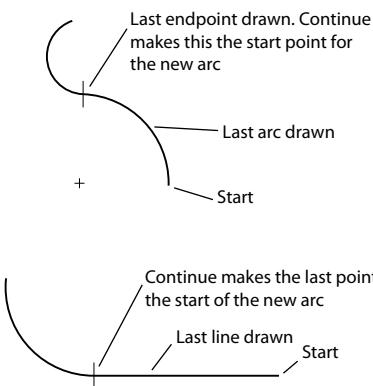

Figure 2.28

**Click:** *Continue from the Draw panel, Arc flyout*

Specify end point of arc: **select an endpoint**

Your drawings should look similar to those in Figure 2.28.

On your own, erase or undo the extra continued arcs and lines that you created.

## Using Arc at the Command Line

To select the Arc command, you can also type the command alias, A, at the command prompt. When you start the Arc command this way, the default is the 3 Points option you used earlier. If you want to use another option, you can type the command option letter at the prompt. You will start the Arc command by typing its alias. You will then specify the start, end, and angle of the arc by typing the command option at the prompt. Refer to Figure 2.27 for the points, 13 and 14, to select.

Command: **A [Enter]**

The command Arc is echoed at the command prompt, followed by

Specify start point of arc or [Center]: **click point 13**

Specify second point of arc or [Center/End]: **E [Enter]**

Specify end point of arc: **click point 14**

Specify center point of arc or [Angle/Direction/Radius]: **A [Enter]**

Specify included angle: **30d54'04" [Enter]**

**Click:** *to turn Dynamic Input button off*

The arc is added to your drawing. However, it may be hard to see because of the small size of the arc relative to the size of the screen and drawing.

## Using Zoom

The Zoom commands change the size of the image on your display. The Zoom flyout is on the ribbon View tab, Navigate panel (Figure 2.29). If it does not already show you can use Show panels to turn it on.

**Right-click in the gray space at the left of the View tab**

**Click:** *Show panels from the context menu, Click Navigate*

The Navigate panel now appears on the ribbon View tab (Figure 2.30).



**Figure 2.30** Navigate Panel on View Tab

To zoom in on an area of the drawing, you can select Zoom In from the Zoom flyout.

**Click:** *Zoom In button*

Your drawing is enlarged to twice its previous size (Figure 2.31).

**Tip:** *After you draw an arc, restarting the command and then pressing the space bar or [Enter] also engages the Continue option. You can use this method to continue a line from the previously drawn arc or line.*

**Tip:** *You can click on the command option from the list instead of typing the letter. Try it both ways.*

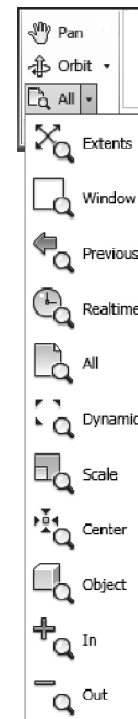

**Figure 2.29**

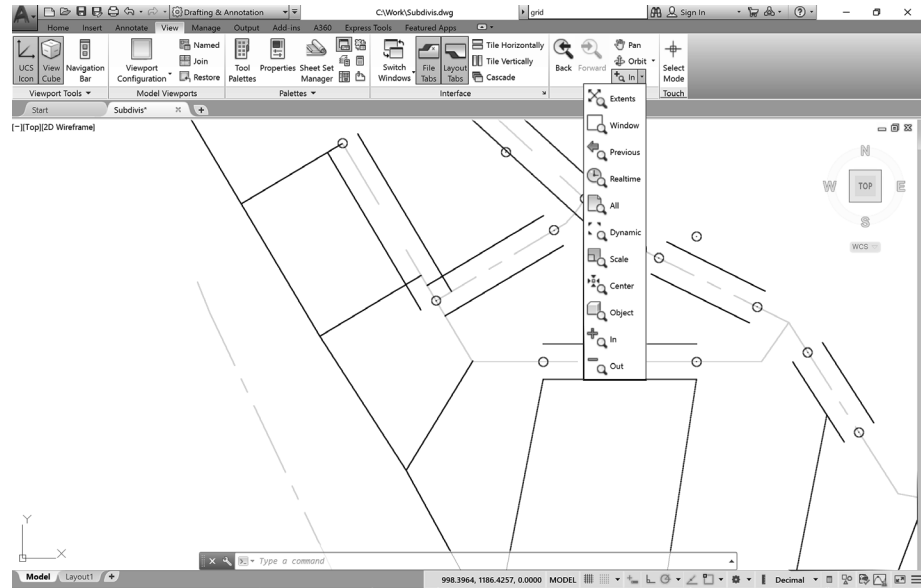

**Figure 2.31**

Next you will zoom out, using the Zoom Out button from the flyout.



**Click: Zoom Out button**

Your drawing should return to its original size on the screen. Zoom In and Zoom Out use the Scale feature of the Zoom command to zoom to a scale of 2X (twice the previous size) and 0.5X (half the previous size).

## Zooming Using Scale Factors

You can also use *scale factors* to zoom when you click the Scale option of the Zoom command. Scale factor 1.00 shows the drawing limits (where the grid is shown). Scale factor 0.5 shows the drawing limits half-size on the screen. Typing X after the scale factor makes the zoom scale relative to the previous view. For example, entering 2X causes the new view to be shown twice as big as the view established previously, as you saw when using Zoom In. A scale factor of 0.5X reduces the view to half the previous size, as you saw when using Zoom Out. Zoom Scale uses the current left corner or (0,0) coordinates as the base location for the zoom. Typing XP after the scale factor makes the new zoom scale relative to paper space. A scale factor of 0.5XP means that the object will be shown half-size when you are laying out your sheet of paper. You will learn more about paper space in Tutorial 5.

You will select the Zoom command by typing its alias at the prompt.

Command: **Z [Enter]**

Specify corner of window, enter a scale factor (nX or nXP), or [All/Center/Dynamic/Extents/Previous/Scale/Window/Object] <real time>: **2X [Enter]**

The view is enlarged to twice the previous size.

Repeat the Zoom command.

Command: **[Enter]** (to restart the last command)

Specify corner of window, enter a scale factor (nX or nXP), or [All/Center/Dynamic/Extents/Previous/Scale/Window/Object] <real time>: **.5 [Enter]**



The drawing limits appear on the screen at half their original size. The area shown on the screen is twice as big as the drawing limits. Now, restore the original view.

Command: **[Enter]** (to restart the Zoom command)

Specify corner of window, enter a scale factor (nX or nXP), or [All/Center/Dynamic/Extents/Previous/Scale/Window/Object] <real time>: **1 [Enter]**

### Zoom Window

To use Zoom Window, create a window around the area that you want to enlarge to fill the screen. This lets you quickly enlarge the portion of the drawing that you are interested in. You can select this command using the Zoom flyout. The Zoom command is “transparent.” This means you can select it during another command. You will zoom in on the area shown in Figure 2.32.

**Tip:** When typing transparent commands, use an apostrophe in front of the command name.

 Click: **Zoom Window icon**  
Specify first corner: **select point A**  
Specify opposite corner: **select point B**

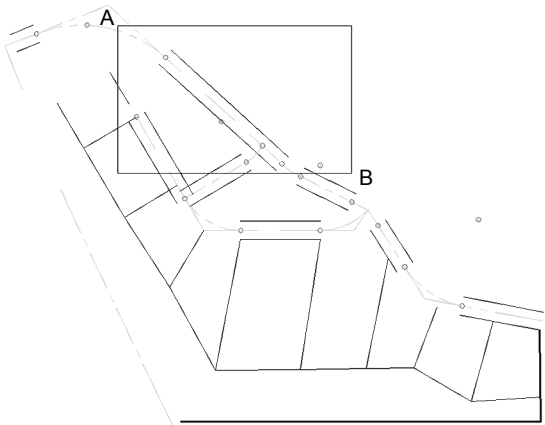

Figure 2.32

The defined area is enlarged to fill the screen as shown in Figure 2.33.

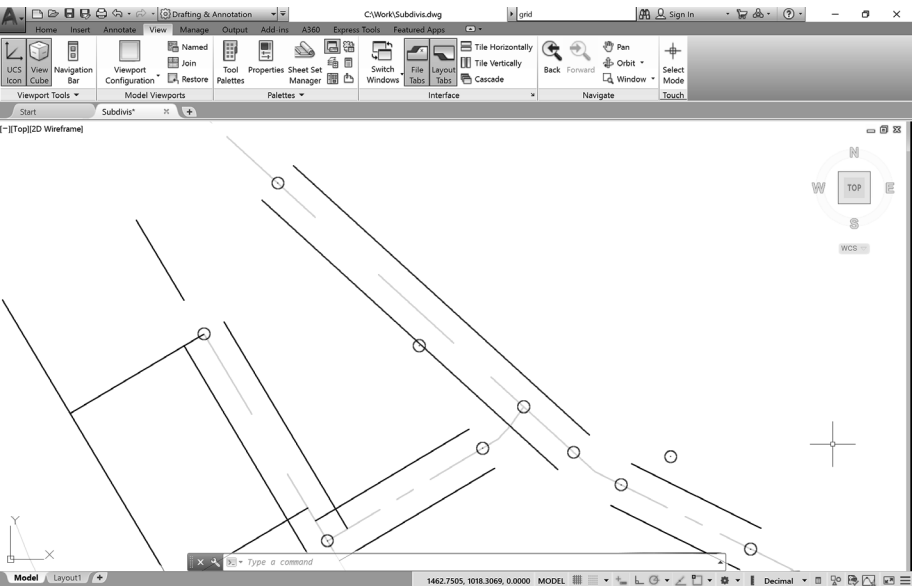

Figure 2.33

## Zoom Previous

To return an area to its previous size, you will click **Zoom Previous** from the Standard toolbar.



**Click: *Zoom Previous button***

Your drawing is returned to its original size. Areas can be repeatedly zoomed, that is, you can zoom in on a zoomed area; in fact, you can continue to zoom until the portion shown on the display is ten trillion times the size of the original.

## Zoom Realtime

An easy way to zoom your drawing to the desired size is to use the **Zoom Realtime** feature on the Standard toolbar.



**Click: *Zoom Realtime button***

Select an arbitrary point in the middle of your drawing and hold down the click button of your pointing device while dragging the cursor up and down. When you move the cursor upward, you zoom in closer to the drawing; when you move the cursor downward, you zoom out farther from the drawing.

***Press ESC or ENTER to exit, or right-click to use the shortcut menu.***

Scrolling the middle mouse wheel acts similar to **Zoom Realtime**. It is quick to use this method at any time during commands.

## Zoom All

**Zoom All** returns the drawing to its original size by displaying the drawing limits, or displaying the drawing extents (all of the drawing objects), whichever is larger. Select the **Zoom All** icon from the **Zoom** flyout.



**Click: *Zoom All button***

The drawing should return to its original size, that is, as it was before you began the **Zoom** command. Experiment on your own with the other options of the **Zoom** command and read about them in the **Help** window.

## Using the Scroll Wheel to Zoom

The scroll wheel on your mouse also provides **Zoom** functions. Try these out now.

***Roll the scroll wheel forward.***

The view of the drawing is enlarged on your screen.

***Roll the scroll wheel towards yourself.***

The view zooms out and appears smaller.

***Double-click the scroll wheel.***

The drawing fills the screen.

**Tip:** If you open a drawing that you've saved with the view zoomed in, you can use **Zoom All** or double-click the scroll wheel to show the full drawing.

## Zoom Dynamic

Another way to zoom in and move around in a large drawing quickly is to use the Zoom Dynamic.

 Click: **Zoom Dynamic**

The *view box* appears on your screen, as shown in Figure 2.34.

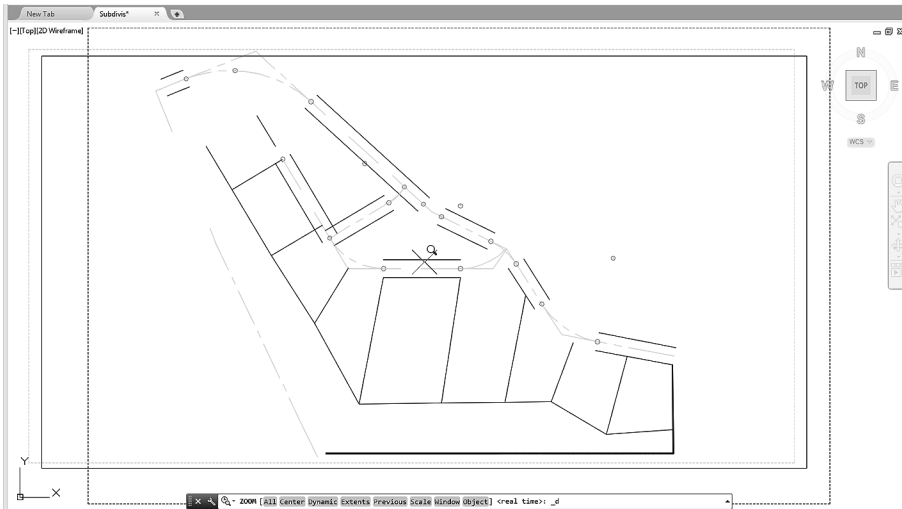

Figure 2.34

**Move your mouse to position the view box.**

The box shows an X in the center, indicating it is in position mode. As you move your mouse around, the view box moves with your mouse movements.

**Position the view box at the location you desire and click the mouse.**

Now an arrow appears at the right edge of the box and as you move your mouse, the size of the box is enlarged or reduced as shown in Figure 2.35.

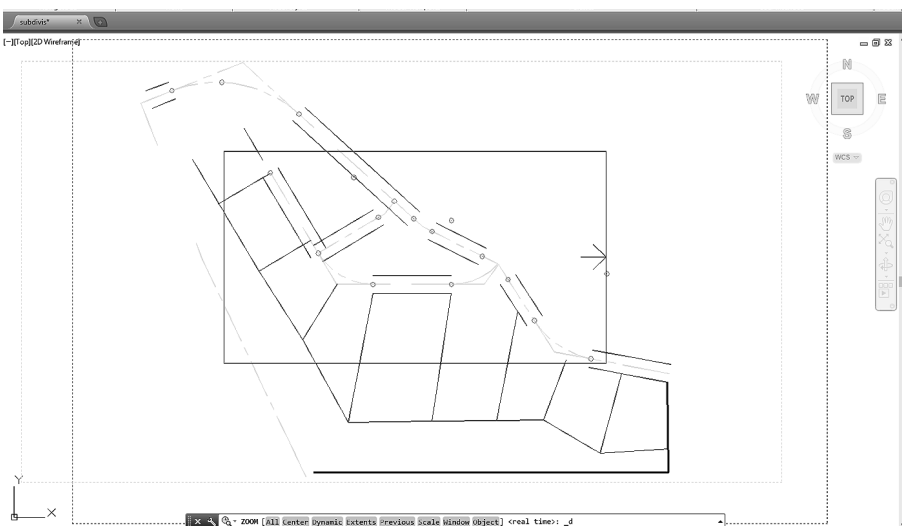

Figure 2.35

**Try reducing the box and then click the mouse button.**

You return to the position mode, so that you can move the box again.

**When you are satisfied with the location of the box, right-click the mouse and select Enter.**

The area enclosed in the box fills the graphics window.

## Using Pan Realtime

The Pan command lets you position the drawing view on the screen without changing the zoom factor. Unlike the Move command, which moves the objects in your drawing to different locations on the coordinate system, the Pan command does not change the location of the objects on the coordinate system. Rather, your view of the coordinate system and the objects changes to a different location on the screen.

**Press and hold the scroll wheel and move your mouse.**

Doing this, you can drag your drawing around on the screen. The drawing should move freely about the drawing area until you let go of the scroll wheel, at which point it will stop.

You can also select to use the Pan command from the ribbon,



Click: **Pan button** from the View tab, Navigate panel

**Press and hold the left mouse button to position the drawing on the screen.**

Press: **[Esc]** or **[Enter]** to exit the command

**Double-click the scroll wheel to Zoom to the drawing extents.**

Your drawing should now fill the drawing window.

## Using Circle Options

In Tutorial 1 you learned to use the Circle command by specifying a center point and a radius value. You can also use the Circle command to draw circles by specifying any two points (Circle 2 Point), any three points (Circle 3 Point), or two tangent references and a radius (Circle Tan Tan Radius). You will use the Endpoint object snap mode to make circles that line up exactly with the ends of the existing lot lines.

Right-click: **Object Snap button** from the status bar

Click: **Endpoint** so it appears checked on the list

The Endpoint and Node running mode object snaps are now turned on. When you see the AutoSnap marker appear on the endpoint of a line, the crosshairs will snap to the marker point. If you see the Node marker, move the crosshairs until the endpoint you want is highlighted.

Click: **LOT LINES** from the Layer Control to make it current

### Circle 2-Point

You will draw a circle using Circle 2-Point. Points 1 and 2 will be endpoints of the circle's diameter, as shown in Figure 2.36.

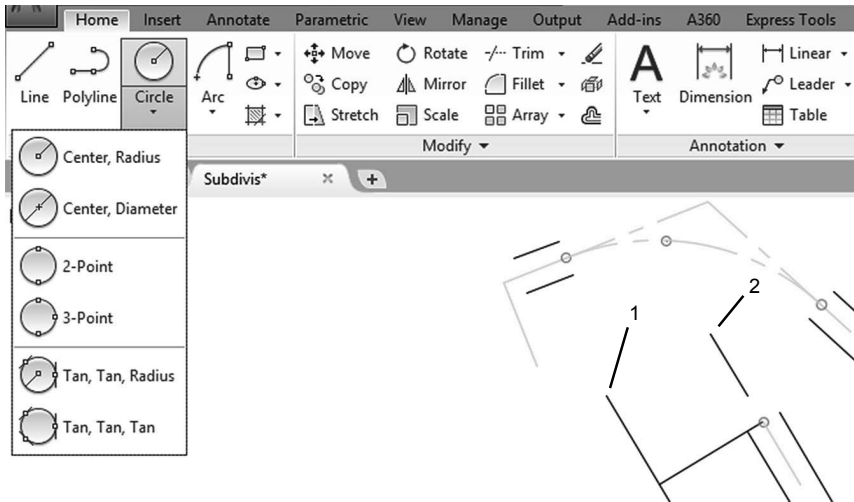

Figure 2.36



Click: **2-Point** button from the Circle flyout

Specify first end point of circle's diameter: **select point 1**

Specify second endpoint of circle's diameter: **select point 2**

The circle has been defined by the two selected endpoints defining its diameter. Your screen should look like Figure 2.37.

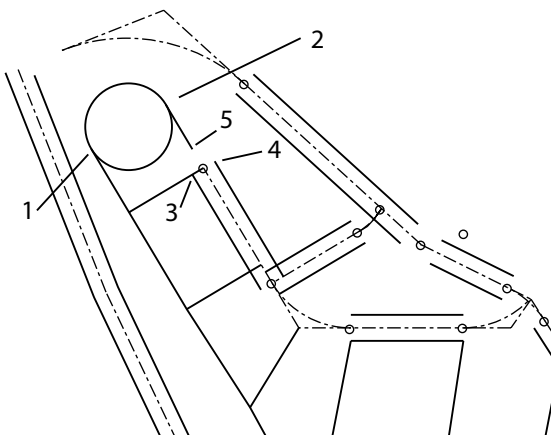

Figure 2.37

## Circle 3-Point

To draw a circle using Circle 3-Point, specify any three points on the circle's circumference. Refer to Figure 2.36 for the points to select.

Click: **3-Point** from the Circle flyout, Home tab Draw panel

Specify first point on circle: **select point 3**

Specify second point on circle: **select point 4**

Because you are in drag mode, you see the circle being created on your screen as you move the cursor.

Specify third point on circle: **select point 5**

The three points on its circumference have defined the circle. Your screen should look like Figure 2.37.

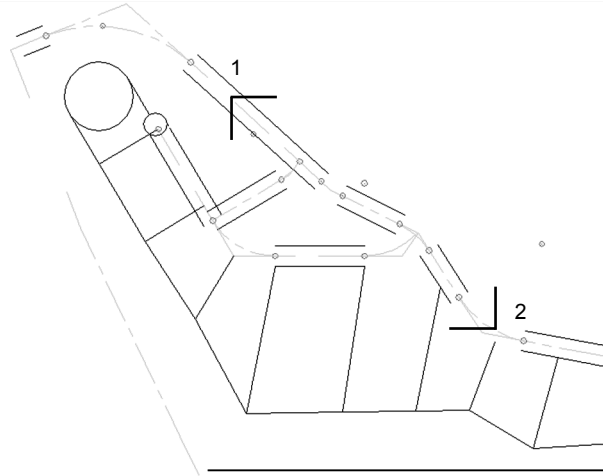

**Figure 2.38**

Next you will draw a circle tangent to two angled centerlines. First, you will change the current layer and zoom in on points 1 and 2, shown in Figure 2.37.

**Tip:** You can quickly zoom in using the scroll wheel on your mouse. To position the area near the center of the drawing window, hold down the scroll wheel to use Pan.

Click: **CENTERLINE** from the Layer Control list to make it current

Click: **Zoom Window** button

Specify first corner: **click point 1**

Specify opposite corner: **click point 2**

The area should be enlarged on your screen, as shown in Figure 2.39.

Click: **Object Snap** button to turn it off

The Object Snap button should now appear unselected, meaning that all running mode object snaps are temporarily turned off. You should do so because sometimes object snaps can interfere with the selection of points and the operation of certain commands. You will use the Circle Tangent, Tangent, Radius option, which uses the Tangent object snap. This will not work well unless other object snaps are turned off.

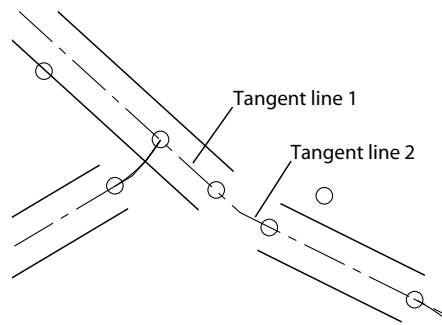

**Figure 2.39**

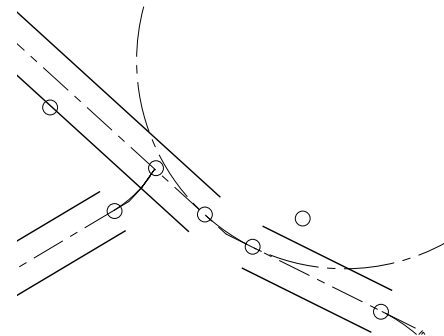

**Figure 2.40**

## Circle Tangent, Tangent, Radius

Circle Tangent, Tangent, Radius requires that you specify two objects to which the resulting circle will be *tangent*. Then give the radius of the resulting circle. This method is frequently used in laying out road centerlines. It involves selecting the two straight sections of the road centerline to which the curve is tangent and then specifying the radius.



Click: **Tan, Tan, Radius** from the Circle flyout on the Draw panel

Note that the AutoSnap marker appears any time the cursor is near a line. Refer to Figure 2.39 for the lines to select. You can select either line first.

Specify point on object for first tangent of circle: **click tangent line 1**

Specify point on object for second tangent of circle: **click tangent line 2**

Specify radius of circle <34.0000>: **267.3098 [Enter]**

A circle with a radius of 267.3098 is drawn tangent to both original lines, as shown in Figure 2.39.

You can also use Circle Tangent, Tangent, Radius to draw a circle tangent to two circles. You will try this next by drawing two circles off to the side of the drawing and then adding a circle that is tangent to both of them.

On your own, draw two circles off to the side of your subdivision drawing.

Click: **Tan, Tan, Radius** from the Circle flyout

Specify point on object for first tangent of circle: **select one of the circles you just drew**

Specify point on object for second tangent of circle: **select the other circle**

Specify radius of circle <267.3098>: **150 [Enter]**

A circle with a radius of 150 is drawn tangent to both circles.

## Circle Tangent, Tangent, Tangent

The Circle Tangent, Tangent, Tangent command lets you quickly define a circle that is tangent to three entities in the drawing.

Try it on your own by selecting the Tan, Tan, Tan button from the Circle flyout and then selecting three lot lines to draw a circle tangent to.

Now erase the extra circles on your own.

## Using Ellipse

The command options for specifying an ellipse can be selected from the Ellipse flyout on the Home tab Draw panel.

Next, you will practice using the Ellipse command by drawing some ellipses off to the side of the drawing. You will erase them when you are through. To draw an ellipse by specifying three points,

**Tip:** If you get the message, *Circle does not exist, the radius you specified may be too small or too large to be tangent to both lines.*

**Tip:** The value shown as the default radius for the circle depends on the size of the last circle you drew.

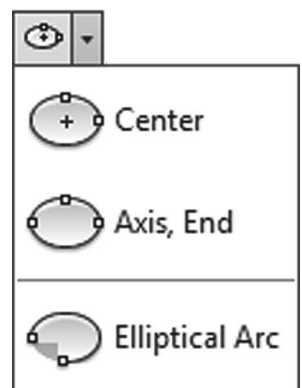

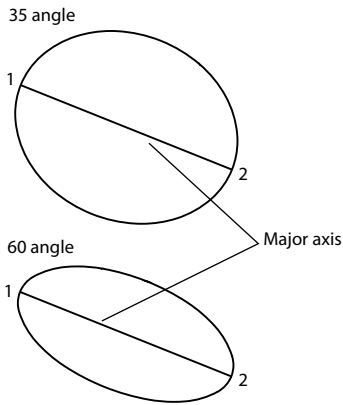

Figure 2.41

Click: **Axis, End button from the Ellipse flyout**

Specify axis endpoint of ellipse or [Arc/Center]: **select a point**

Specify other endpoint of axis: **select a point**

Specify distance to other axis or [Rotation]: **select a point**

An ellipse is created on your screen, using the three points that you selected. The ellipse has a *major axis* (the longest distance between two points on the ellipse) and a *minor axis* (the shorter distance across the ellipse). The AutoCAD program determines which axis is major and which is minor by examining the distance between the first pair of endpoints and comparing it to the distance specified by the third point.

One way to describe an ellipse is to create a circle and then tip the circle away from your viewing direction by a rotation angle. This method requires you to specify the angle of rotation instead of the endpoint of the second axis.

You will draw an ellipse using two endpoints and an angle of rotation. See Figure 2.41 to determine the location of the points.



Click: **Axis, End button from the Ellipse flyout**

Specify axis endpoint of ellipse or [Arc/Center]: **select point 1**

Specify other endpoint of axis: **select point 2**

This defined the distance between points 1 and 2 as the major axis (diameter) of the ellipse. This time at the command prompt, use the options to specify the rotation angle, as though tipping a circle.

Specify distance to other axis or [Rotation]: **R [Enter]**

Specify rotation around major axis: **35 [Enter]**

On your own, **erase** the ellipses that you created.

The remaining construction methods for ellipses are similar to specifying the axes, but use radius values rather than diameter values. This way, when the center point of the ellipse is known, you can use it as a starting point. Refer to Figure 2.42 for the locations of the points in the next steps. This time type the command.

Command: **ELLIPSE [Enter]**

Specify axis endpoint of ellipse or [Arc/Center]: **C [Enter]**

The center of the ellipse is the intersection of the major and minor axes. You can enter a coordinate or use the cursor to select a point on the screen.

Specify center of ellipse: **select point 1**

Next, you provide the endpoint of the first axis. The angle of the ellipse is determined by the angle from the center point to this endpoint.

Specify endpoint of axis: **select point 2**

Now specify the distance measured from the center of the ellipse to the endpoint of the second axis, measured perpendicular to the first axis (or a rotation angle can be used).

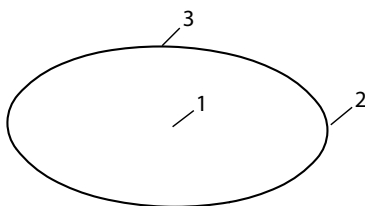

Figure 2.42



Specify distance to other axis or [Rotation]: **select point 3**

The point that you selected determined whether the first axis is a major or minor axis. The ellipse is drawn on your screen.

Next, draw an ellipse by specifying a center point, one axis point, and an angle of rotation. Refer to Figure 2.43.



Click: **Center from the Ellipse flyout**

Specify center of ellipse: **click point 1**

Specify endpoint of axis: **click point 2**

Specify distance to other axis or [Rotation]: **R [Enter]**

Specify rotation around major axis: **30 [Enter]**

Before you go on, **erase** the ellipses you drew for practice.

Use Zoom All to return to the original view.

Save your drawing at this time.

When you have successfully saved your drawing,

Click: **Application button, Exit AutoCAD**

You are now back at the Windows desktop.

You will finish the subdivision drawing in Tutorial 3.

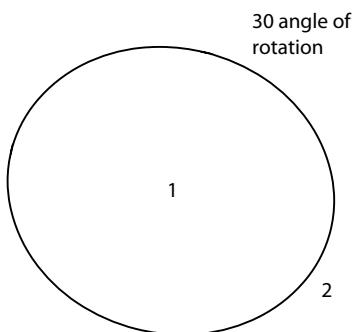

Figure 2.43

**Tip:** Recall that AutoCAD keyboard entry is not case-sensitive. You can type uppercase, lowercase, or mixed-case letters. In this book your keyboard entry is shown uppercase to help you identify easily what you are supposed to type, but the program does not require uppercase letters.

**Tip:** Notice that when you pick the Center button from the Ellipse flyout, the “C” option is automatically selected at the command prompt: Specify axis endpoint of ellipse or [Arc/Center]: **C**

**Tip:** If you have older AutoCAD versions you can use the Save As command to save your drawing to the 2010, R14 or other formats. In the Save Drawing As dialog box, scroll through the Save Drawing Type list for the various options.

## Key Terms

---

chord length	freeze	minor axis	running object snap
concave arc	included angular value	object snap	scale factor
convex arc	layer	override mode	tangent
current layer	locked layer	primitives	target
delta angle	major axis	regenerate	virtual screen

## Key Commands (keyboard shortcut)

---

Arc (A)	Circle Tan, Tan Radius	Open Drawing (CTRL+O)	Zoom In
Arc, 3 Points	Circle Tan, Tan, Tan	Pan Realtime (P)	Zoom Out
Arc, Continue	Color Control (COL)	SAVEAS	Zoom Previous
Arc Start, Center, End	DTEXT	Snap to Endpoint	Zoom Realtime
Arc Start, Center, Length	Ellipse (EL)	Snap to Node	Zoom Scale
Arc Start, End, Angle	Layer (LA)	Text	Zoom Window
Arc Start, End, Radius	Layer Control	Zoom (Z)	
Circle 2-Point	MTEXT	Zoom Dynamic	
Circle 3-Point	Object Snap (F3)		

## Exercises

Redraw the following shapes. If dimensions are given, create your drawing geometry exactly to the specified dimensions. The letter M after an exercise number means that the dimensions are in millimeters (metric units). If no letter follows the exercise number, the dimensions are in inches. Do not include dimensions on the drawings. The  $\varnothing$  symbol means diameter; R indicates a radius.

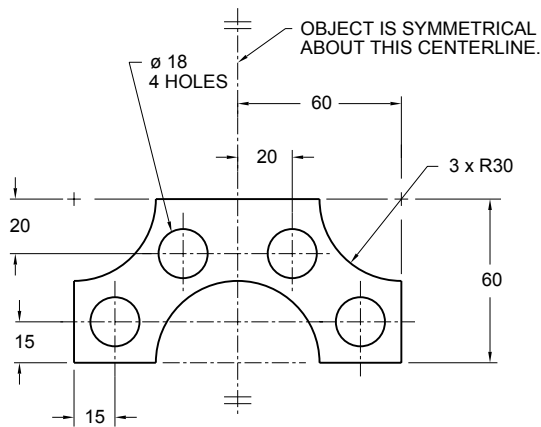

 **Exercise 2.1M Bracket**

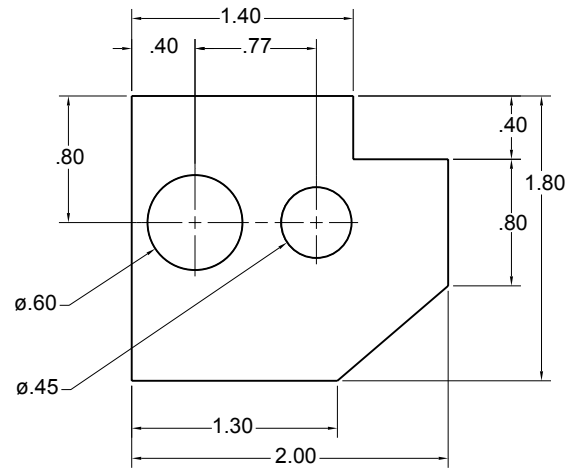

 **Exercise 2.2 Gasket**

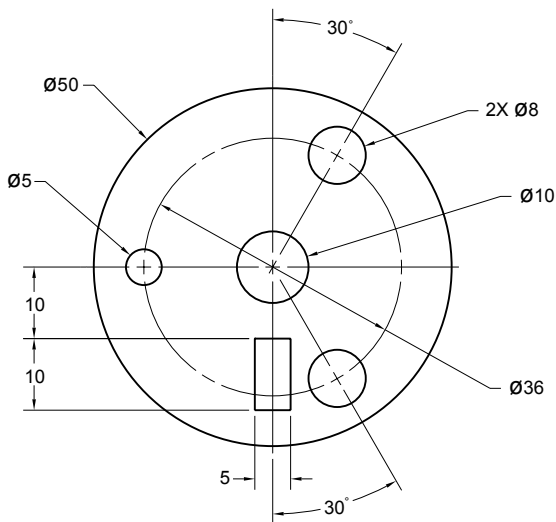

 **Exercise 2.3M Flange**

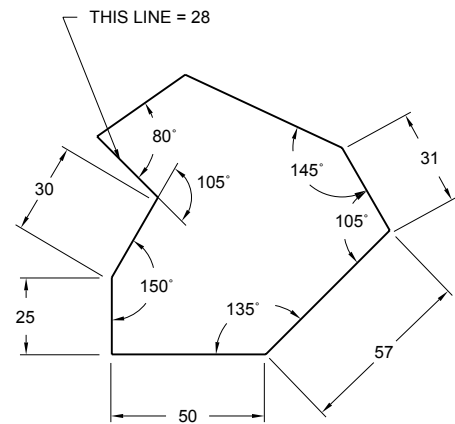

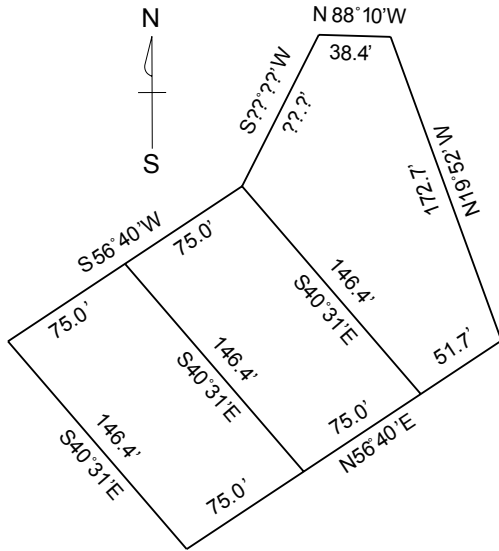

 **Exercise 2.4M Puzzle**

Draw the figure shown according to the dimensions provided. From your drawing determine what the missing distances must be (Hint: use DIST).

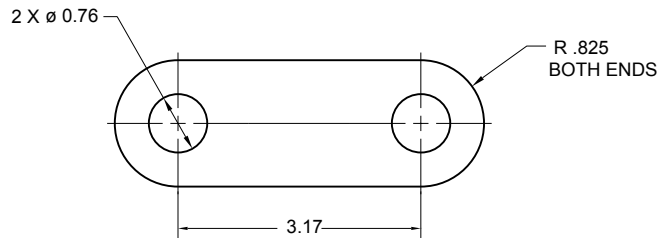

 **Exercise 2.5 Plot Plan**



 **Exercise 2.6 Link**

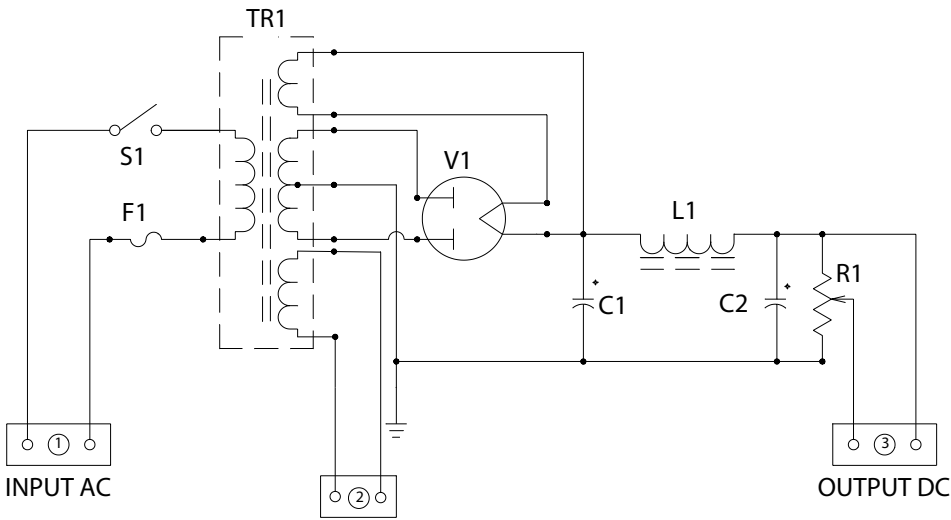

**POWER SUPPLY**

 **Exercise 2.7 Power Supply**

Draw this circuit, using the techniques you have learned.

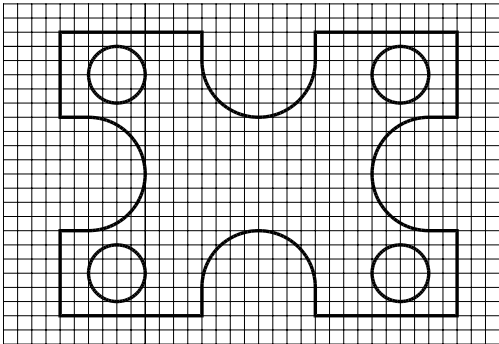

 Exercise 2.8 Gasket

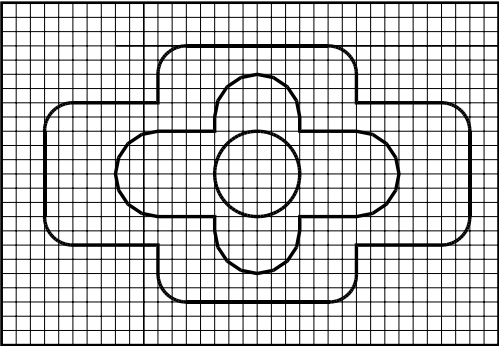

Exercise 2.9 Shape

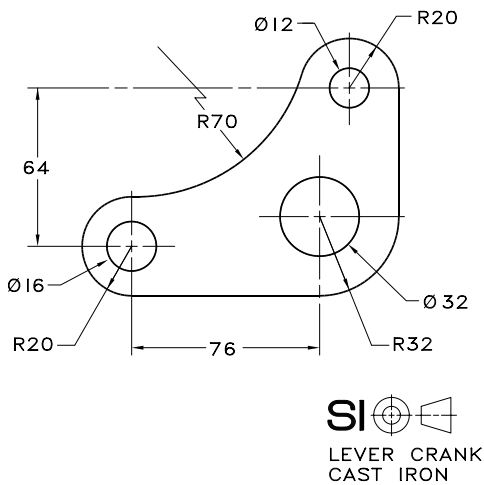

 Exercise 2.10M Lever Crank

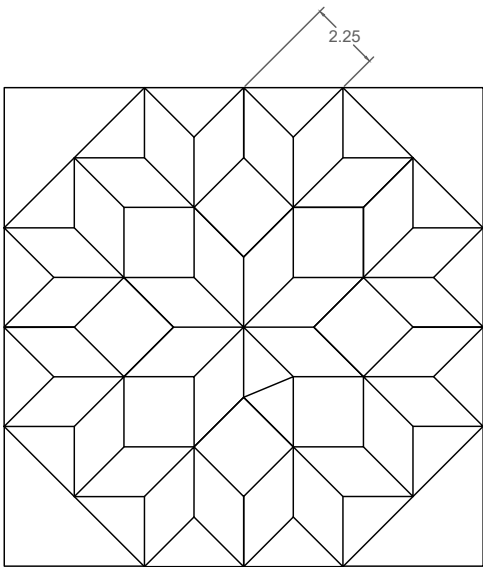

Exercise 2.11 Star Quilt Block

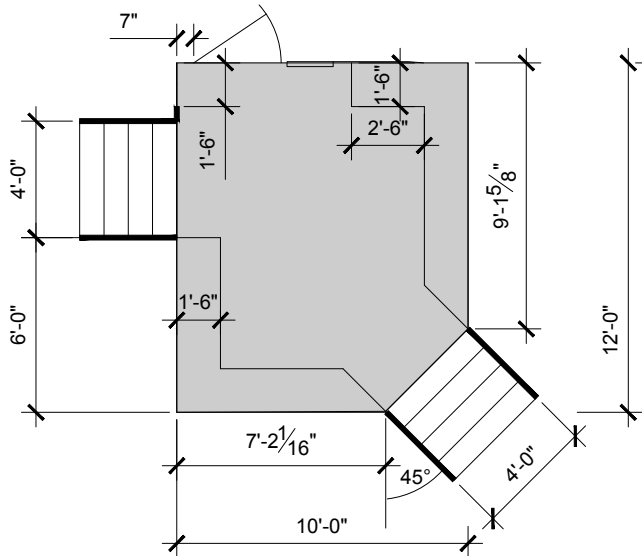

 Exercise 2.12 Deck Plan