

Certified SOLIDWORKS® Expert Preparation Materials

SOLIDWORKS® 2018

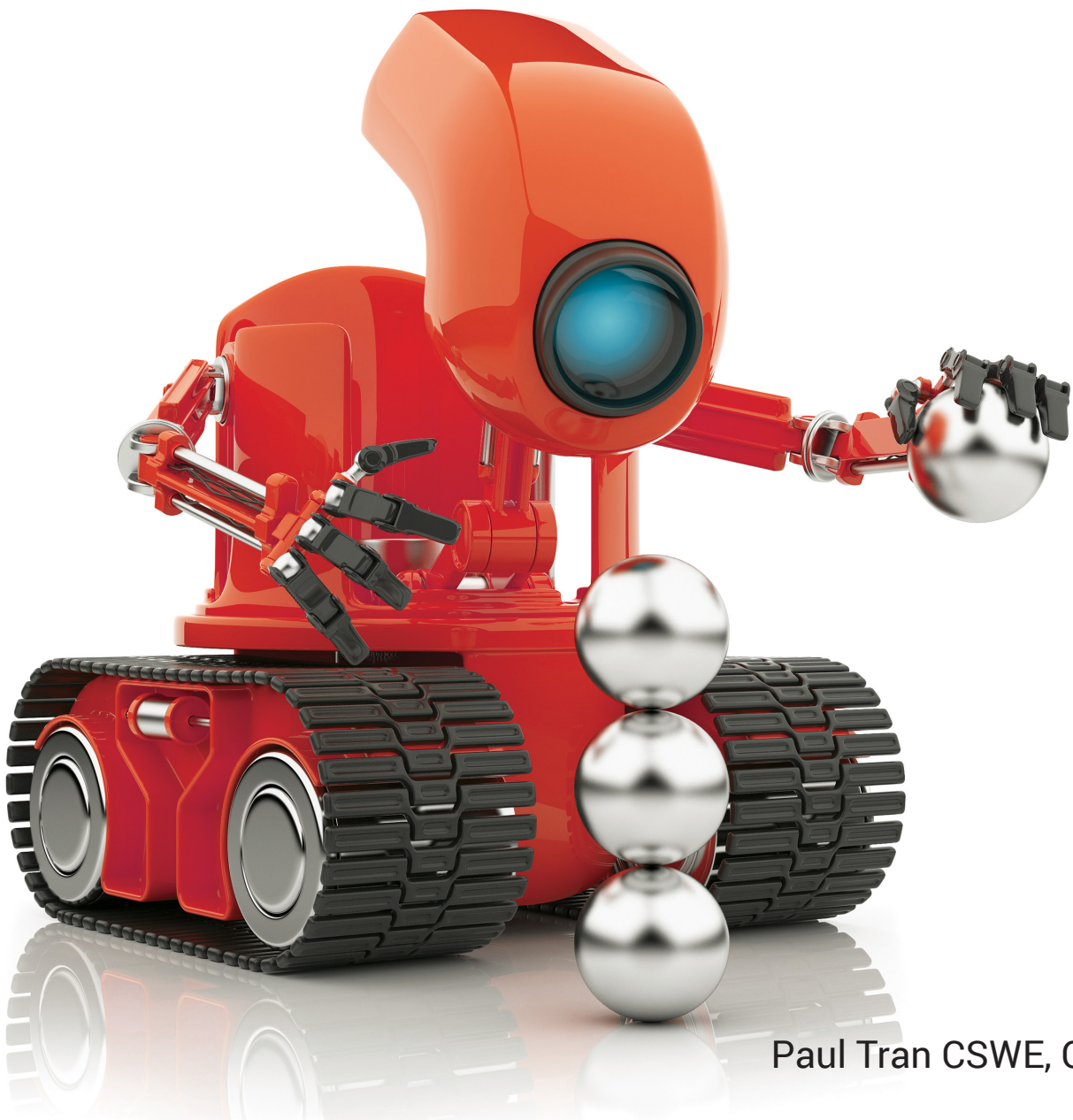

Paul Tran CSWE, CSWI

Visit the following websites to learn more about this book:



[amazon.com](https://www.amazon.com)

[Google books](https://books.google.com)

[BARNES & NOBLE](https://www.barnesandnoble.com)

CHAPTER 1

Using Belt Chain

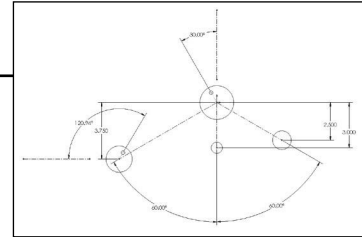

CSWE Exam Preparation Using Belt Chain

Belt / Chain is one of the unique features in SOLIDWORKS for designing sprockets, belts and pulleys.

The pulleys are created as a single sketch and converted into blocks. They get positioned with relations and dimensions, then a belt is added and its length is determined by the pulleys' positions.

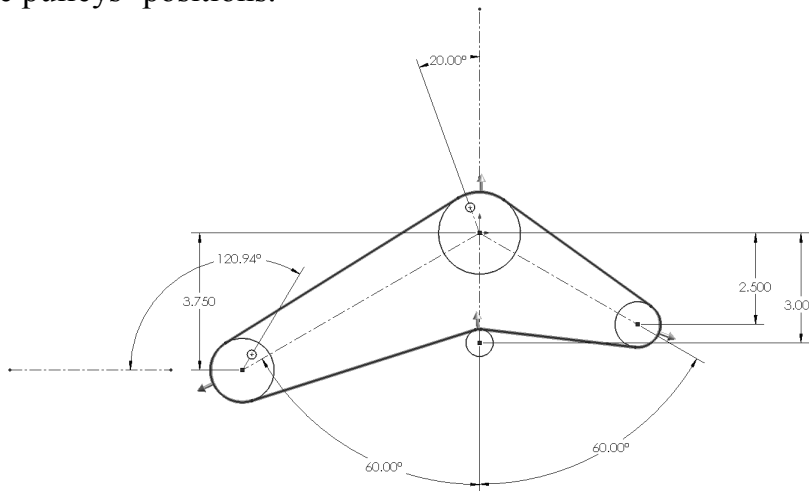
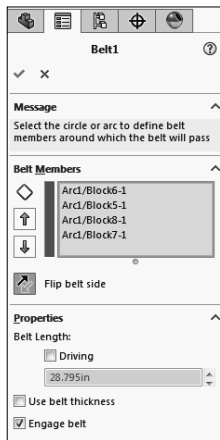

Depending on the location of the pulleys, SOLIDWORKS calculates the length for the belt automatically. Once the belt is created, the belt length can be altered and the pulleys are adjusted accordingly.

This chapter will guide you through the creation of the pulley system shown above. Four blocks will be developed independently, with an addition of a belt which will wrap around them. Next, a driving angular dimension will be utilized to test the movement of the pulleys. Then, when the angle is changed, not only will the pulleys move, but the length of the belt will be updated as well.

CSWE Exam Preparation

Using Belt Chain

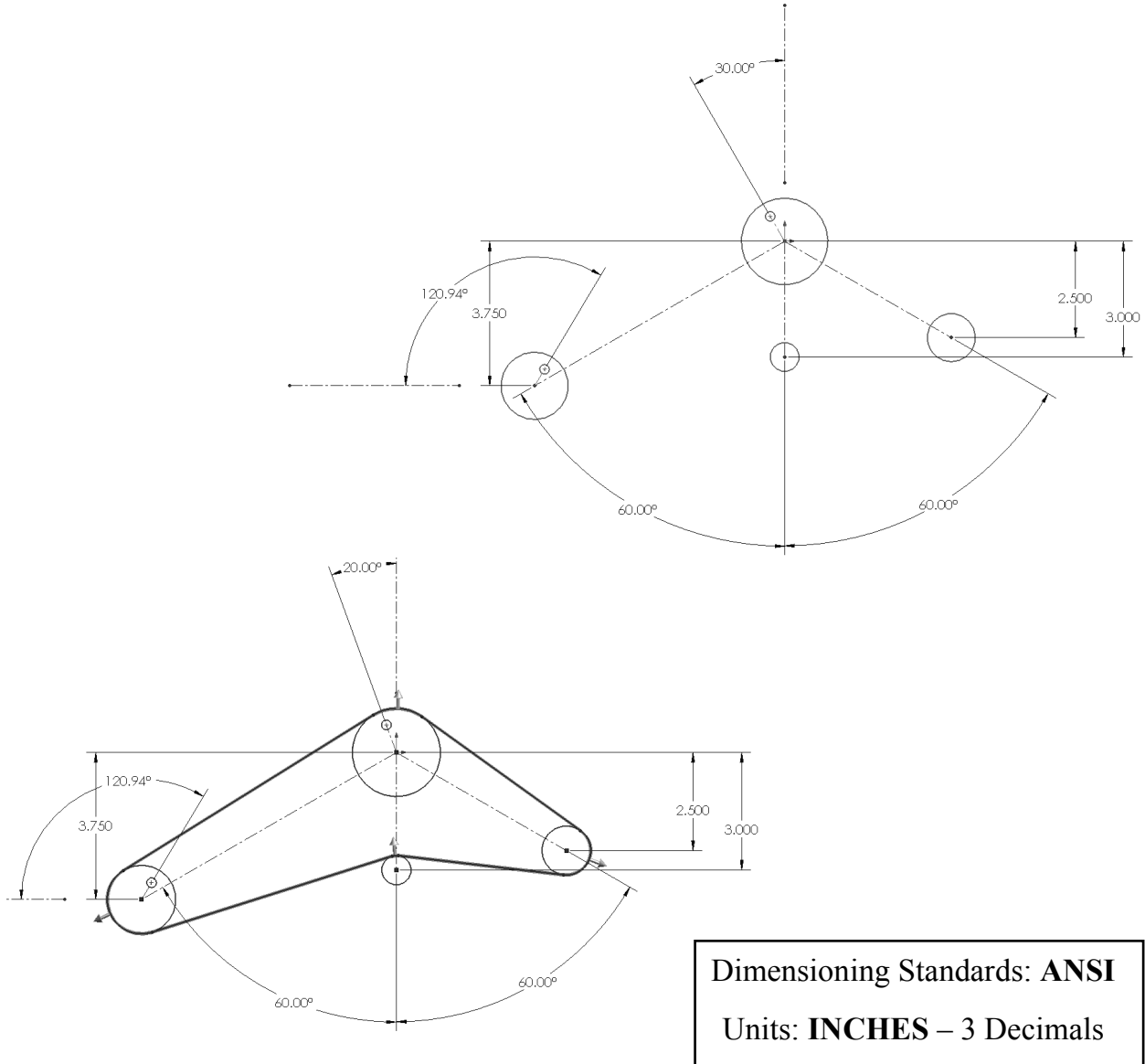

Tools Needed:



Sketch



Circle



Smart Dimension



Add Relation



Make Block



Belt Chain

1. Starting a new part template:

- Click **File / New**.
- Select the **Part** template and click **OK**.
- Select the system of unit **IPS** from the bottom right of the screen (Inch, Pound, Second).
- Select the **Front** plane and open a new sketch.

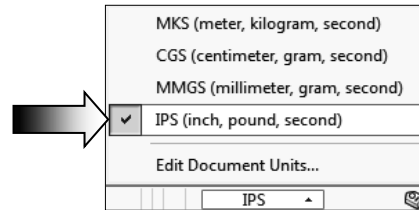
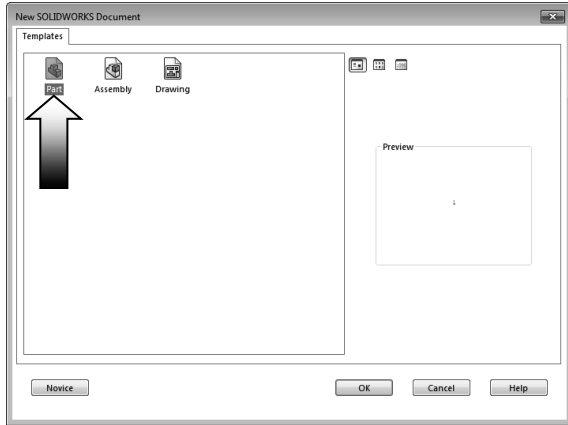

2. Creating the main sketch:

- Start sketching from the origin; add the centerlines and the circles as shown below. There should be a total of 7 centerlines all together.
- There should be 1 vertical and 1 horizontal centerline that are drawn away from the rest of the entities; one of them should be coincident to the origin, and the other is coincident to the center of the $\text{Ø}1.750$ circle. These centerlines will be used to add the driving angular and reference dimensions.

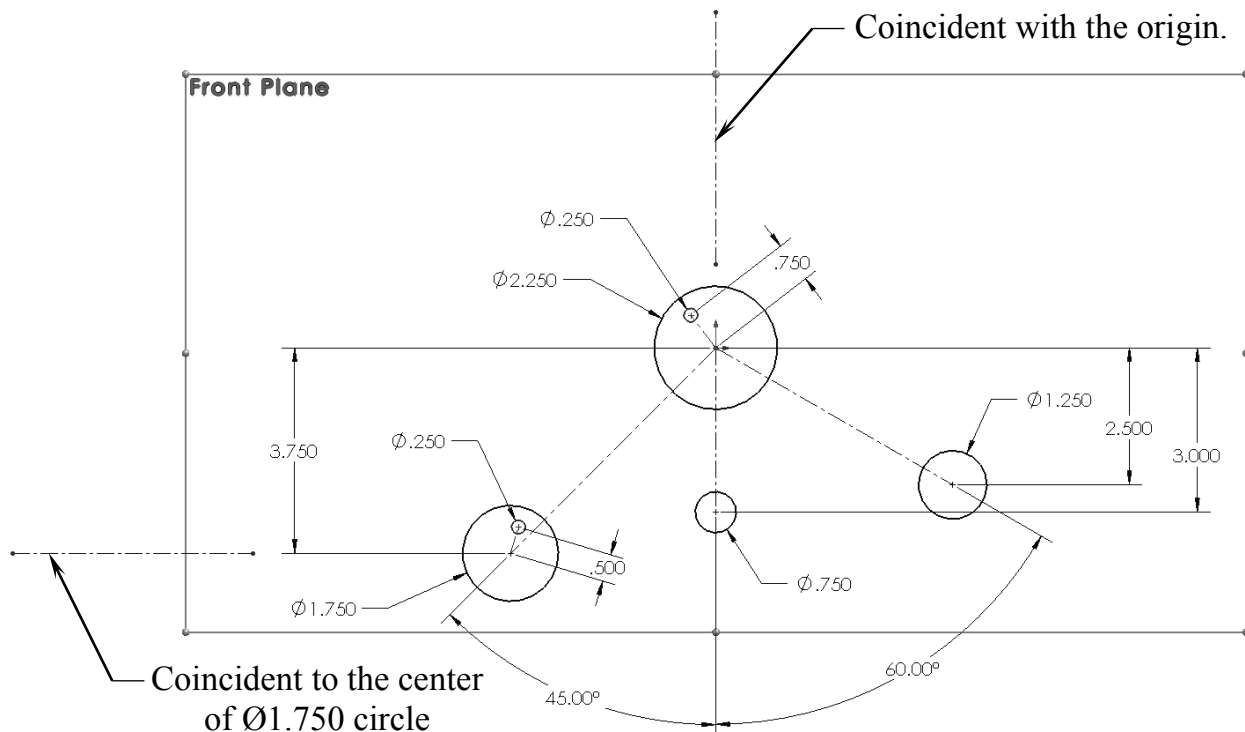

3. Making the blocks:

- A set of sketch entities and dimensions can be made into a group, or block. These blocks are used when creating the belt chain or the pulley systems.

- Box-select around the upper circle, including the small circle. As soon as the mouse button is released, a small menu appears; select the **Make Block** button from it (arrow).

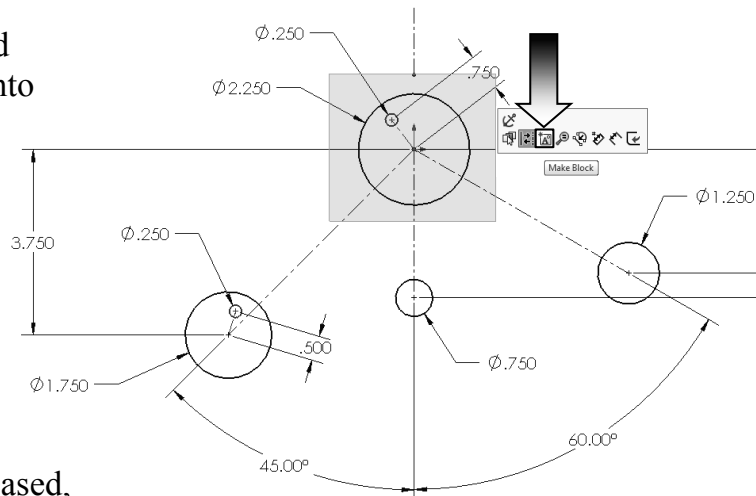

- We can ignore the Insertion Point since we do not need to re-use these blocks anywhere else.

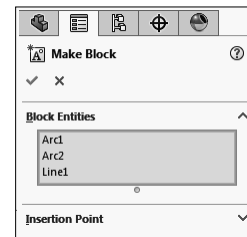

- Click **OK**.

- The selected circles turn gray indicating that they have been made into a block.

- Repeat the previous step by box-selecting around the circles on the left side.

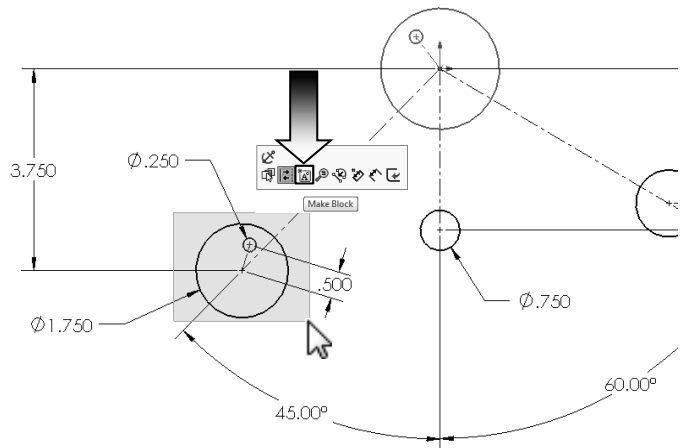

- Leave the dimensions when selecting the block; we do not need them to be part of the block.

- Click **OK**.

- The 2nd block is also changed to the gray color.

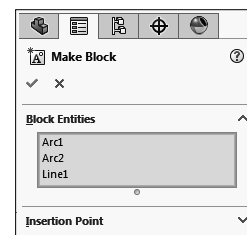

CSWE 2018 | Exam Preparation | Using Belt Chain

- Repeat the previous step and make the 3rd block.
- The 3rd block has only one circle, and similar to the last steps, we can just leave out the Insertion Point.
- Click **OK**.
- The last block, block number 4, is also created the same way. This block has only the $\text{Ø}1.250$ circle in it.
- On the FeatureManager, there should be only one sketch with 4 blocks under it.

4. Creating a Belt Chain:

- Click **Tools / Sketch Entities / Belt Chain**.

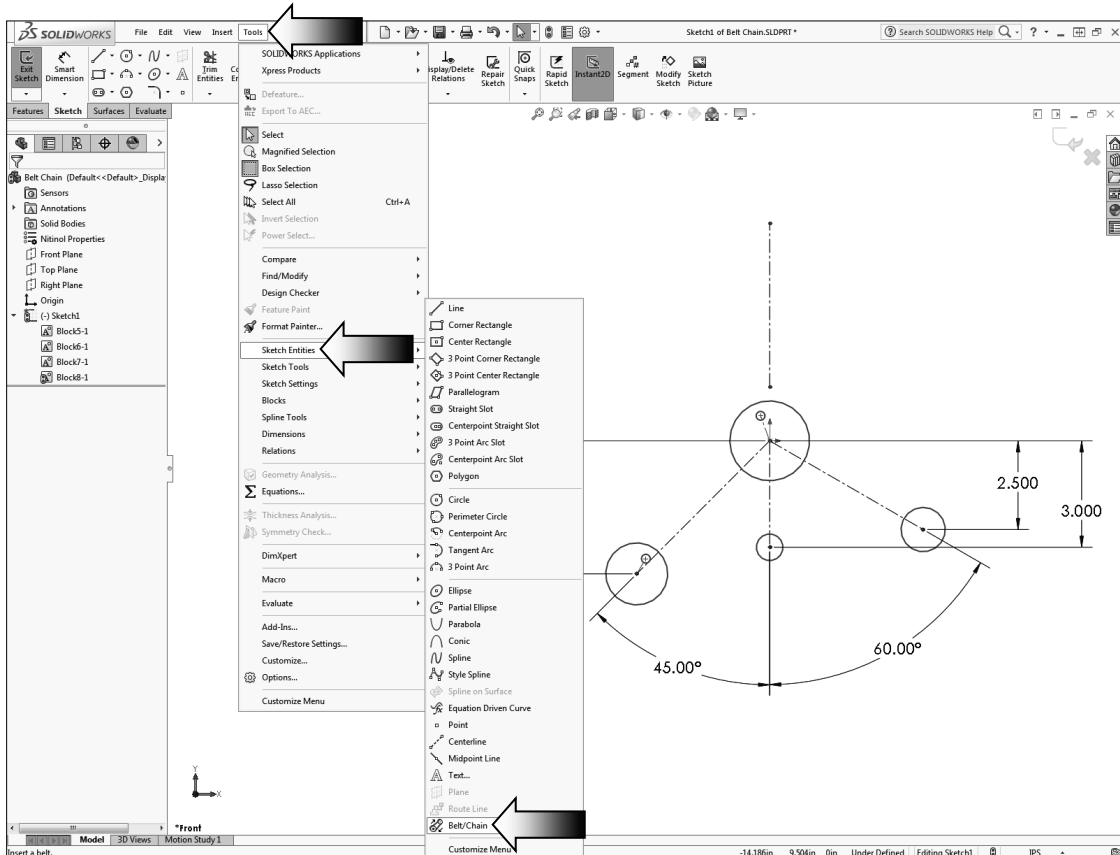
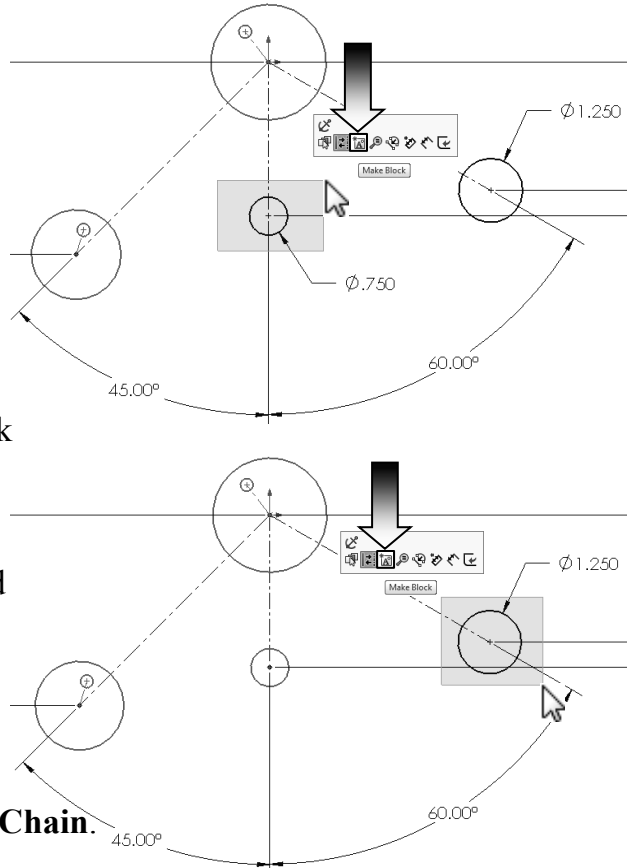

CSWE 2018 | Exam Preparation | Using Belt Chain

- To create a belt that wraps around these blocks, begin by clicking the circles in the order shown on the right.

- As you select the circles, the preview of a belt appears along with a "Flip Direction" arrow. Click these arrows as needed to change the wrap directions (arrow).

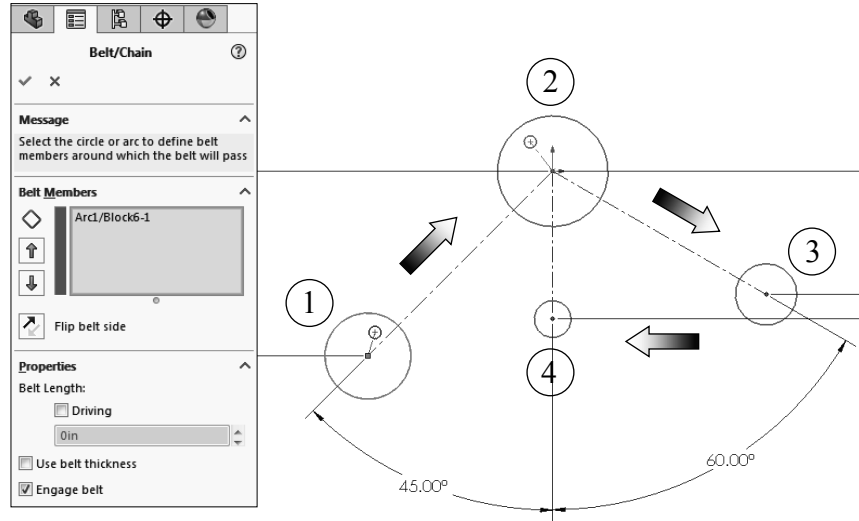

- After completing one revolution, compare your result with the image below and make any adjustments as needed. Flip the direction arrow for the small pulley as indicated.

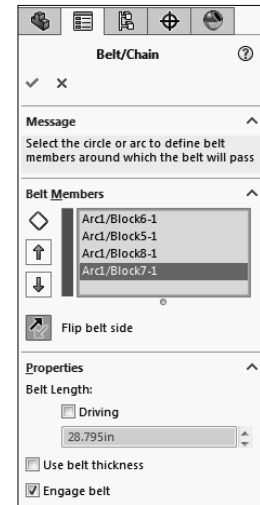
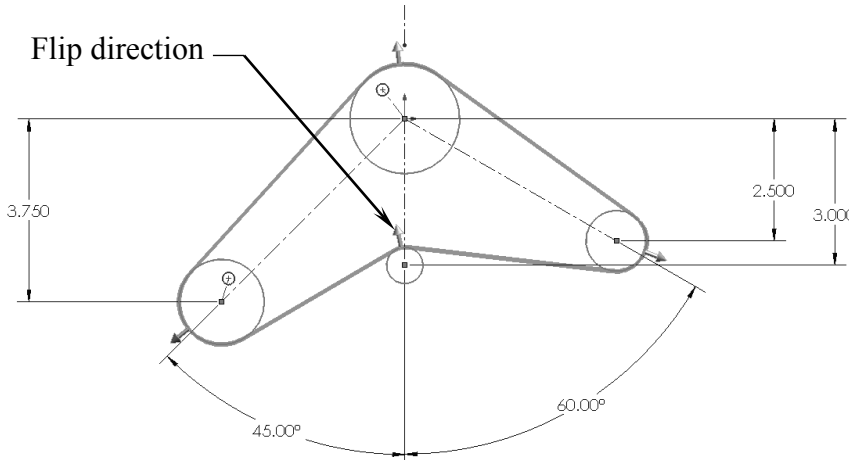

- Leave the checkbox for Driving unchecked. We will add a couple of Angular dimensions and use them to change the length of the belt in the next couple of steps.

- Check the length of the belt as this will be one of the questions in the Expert's exam.

- Using only two decimals enter the length of your belt here:

Belt Length = _____

5. Adding the Angular dimensions:

- We are going to add a couple of angular dimensions; one of them will be used as the driving dimension, and the other, the reference dimension.

- Select the Smart-Dimension command and click the two centerlines as noted.

- Enter **30deg** for angle and click **OK**.

- Next, add another angular dimension between the 2 lines of the 2nd block as noted. This dimension causes the sketch to become over defined, and the 1st angular dimension also turns to yellow. This indicates the two dimensions are conflicting with one another.

- Click the option **Leave-This-Dimension-Driven** (default) to overcome the error. This option will also revert the 1st angular dimension back to its driving status.

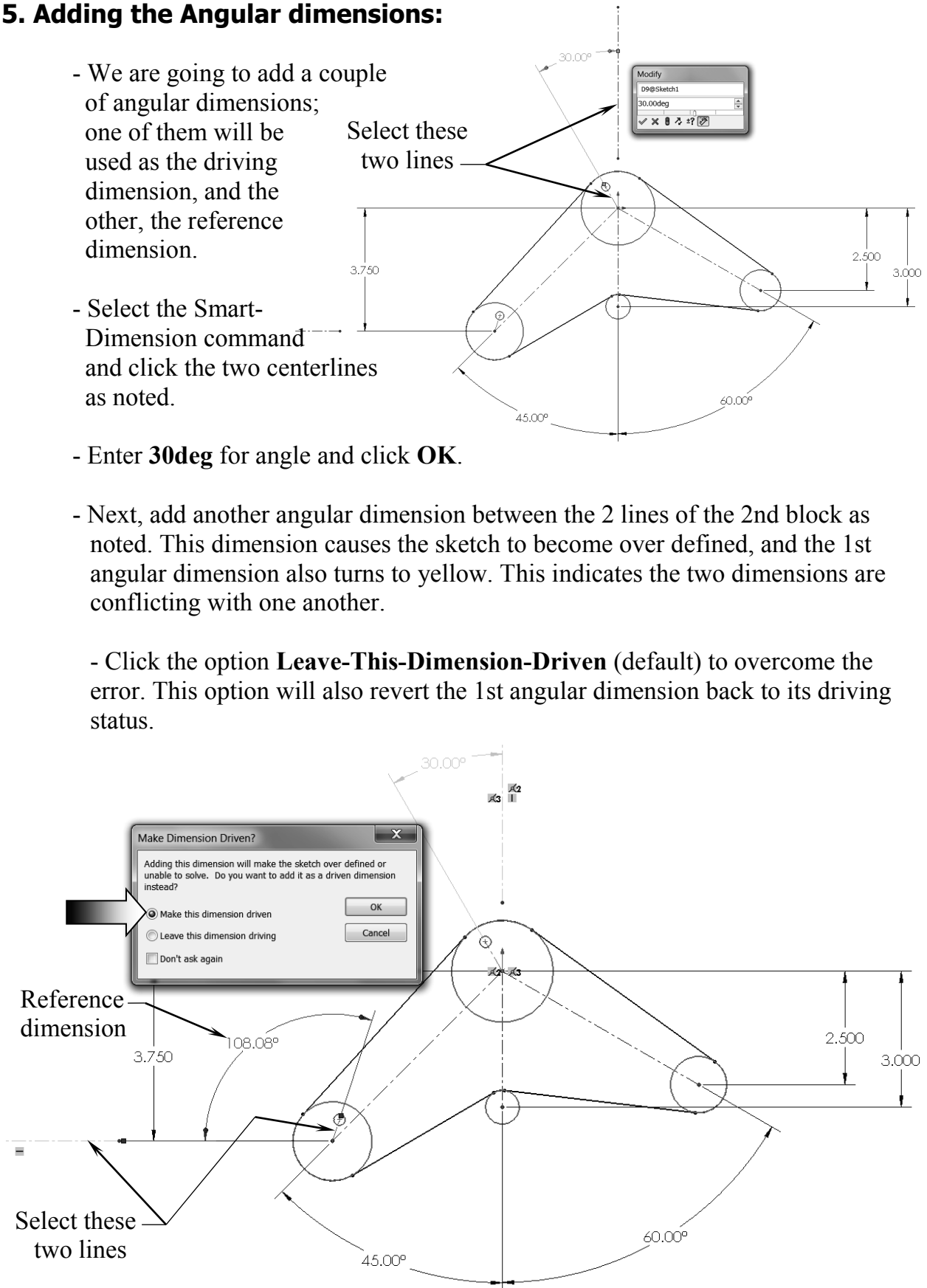

6. Applying dimension changes:

- Double click the driving dimension and change the value to **45deg**.
- Click **Rebuild** to execute the change.

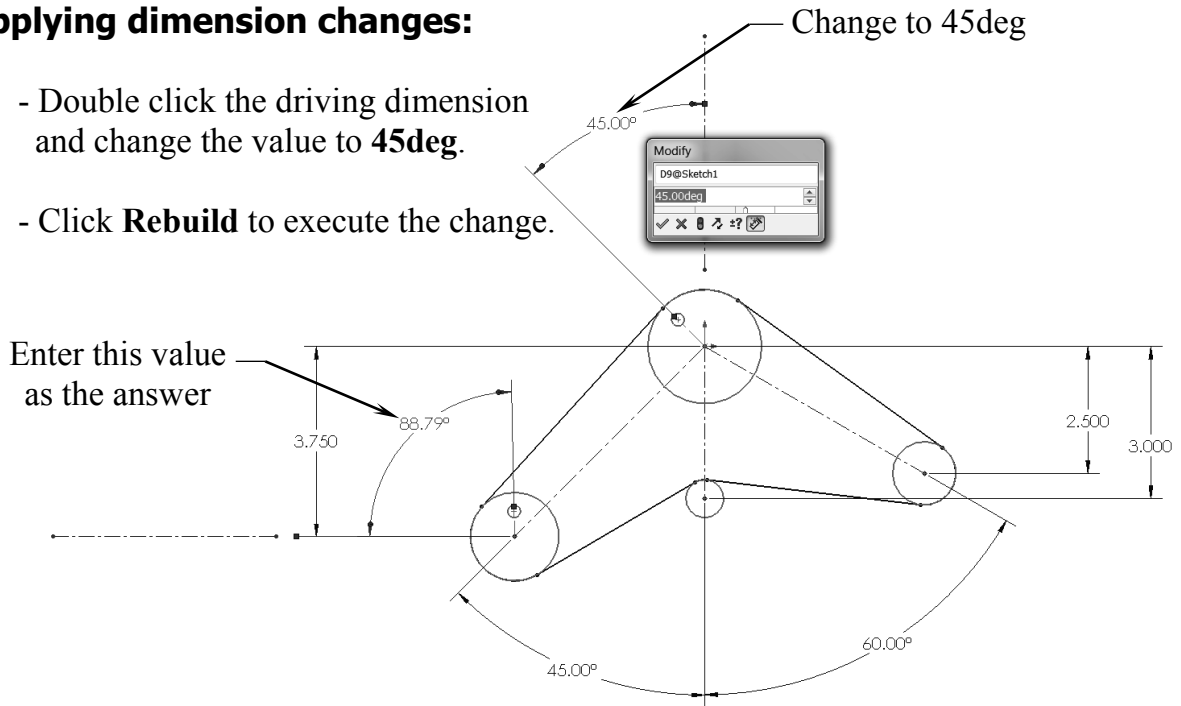

- Using 2 decimals, enter the value of the reference dimension here: _____ deg.
- Once again, change the value of the Driving dimension from 45deg to **20deg**.
- Click **Rebuild** to update the change.

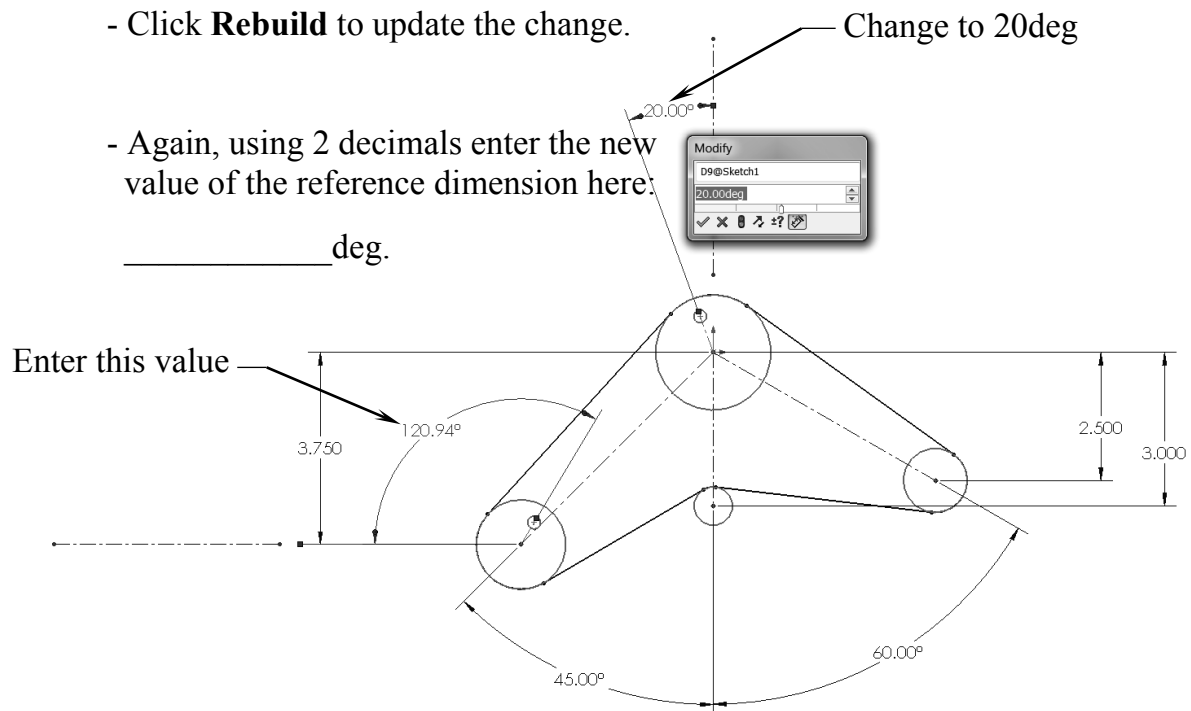

7. Checking the belt length:

- Double click the belt as noted.

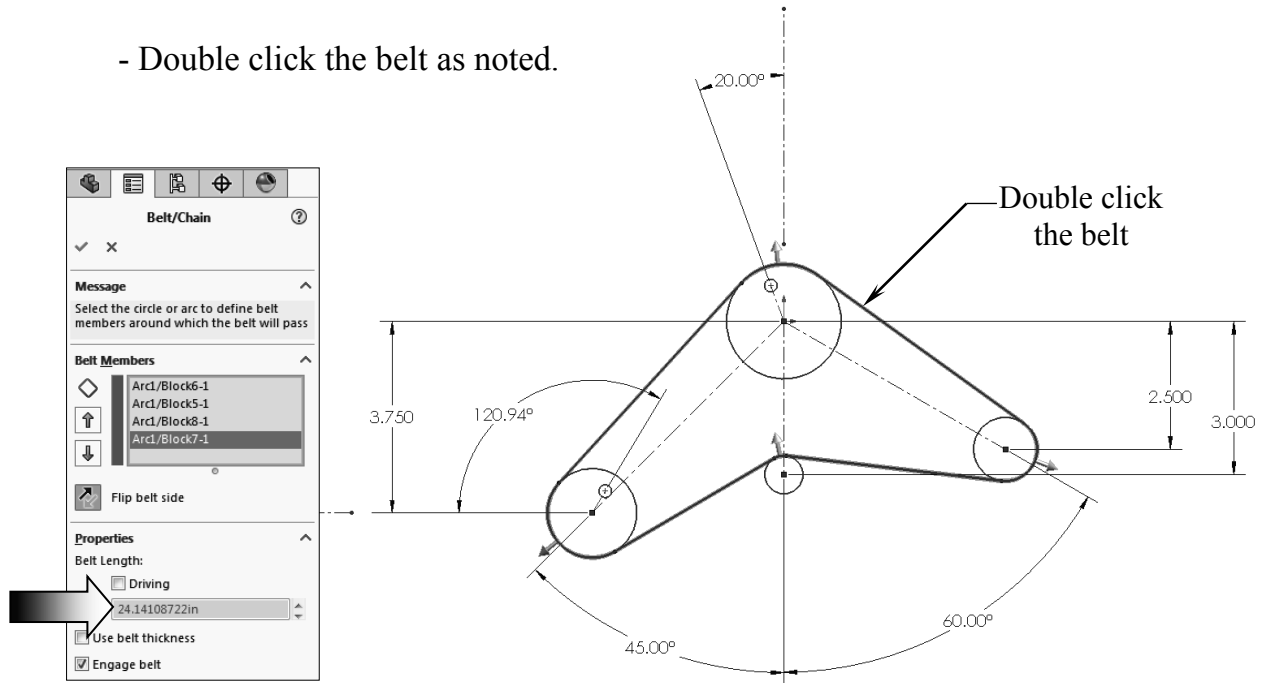

- At 20deg angle, the current belt length should be listed as **24.141in**.

- Click **OK**.

8. Changing the pulley's angle:

- Double click the 45deg dimension at the lower left corner of the sketch and change it to **60deg**.

- Click **Rebuild** to update the change.

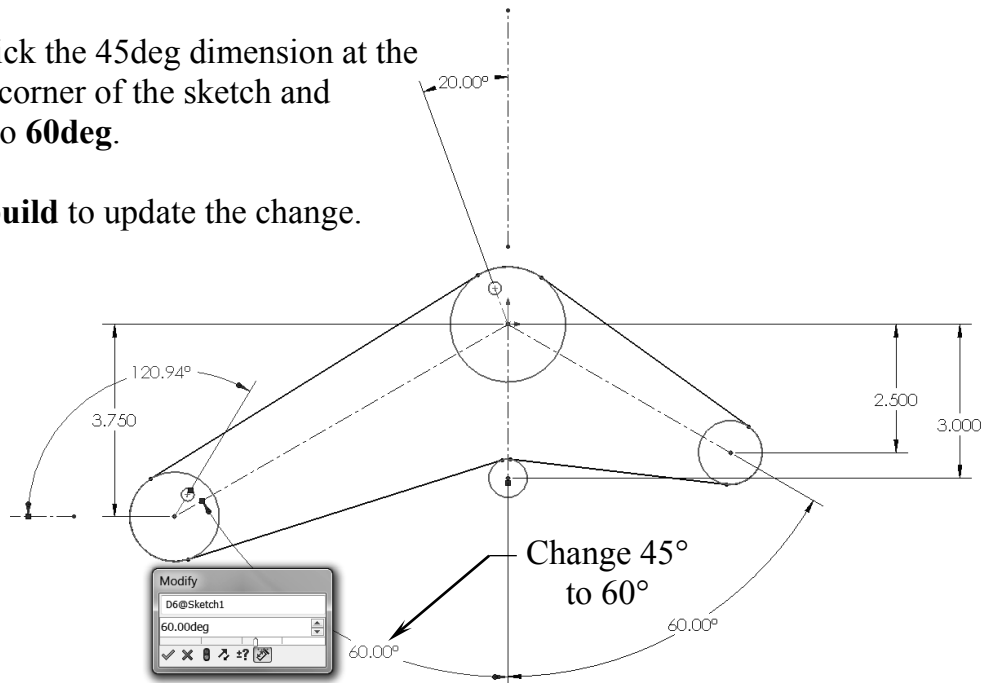

9. Verifying the new belt length:

- Double click the belt to reactivate it.

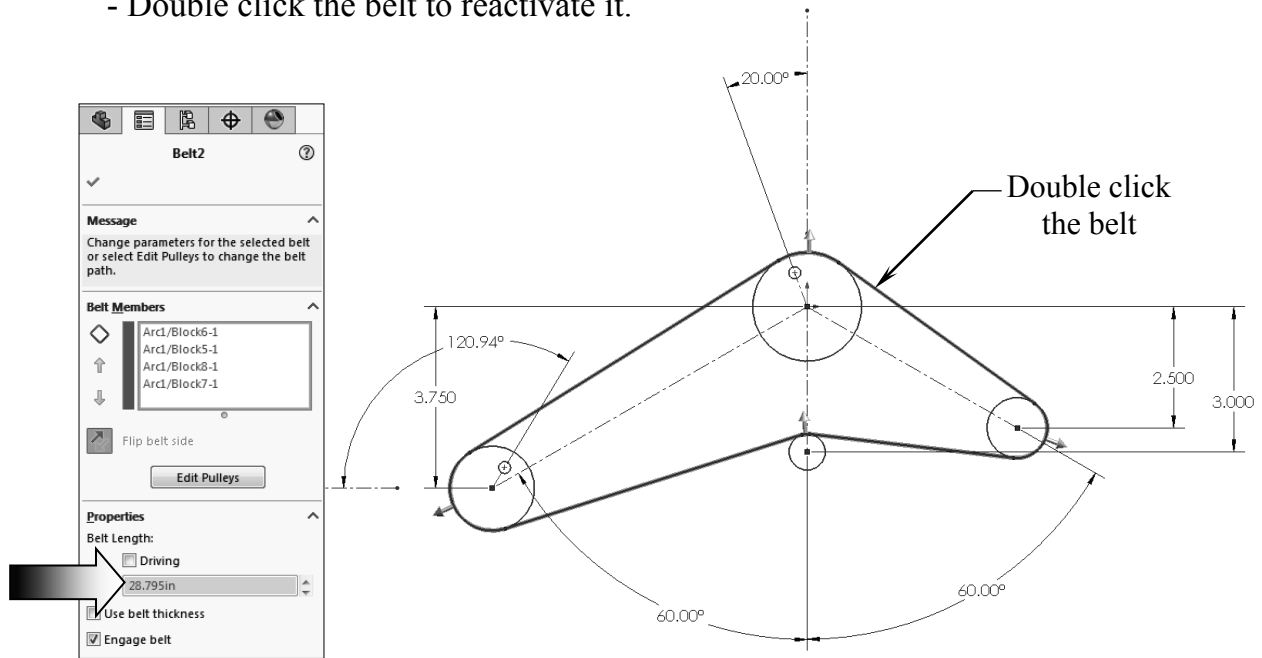

- The belt length has been increased as the result of the last dimension change.
- Enter the new belt length here: _____ in.

10. Saving your work:

- Click **File / Save As**.
- Enter **Belt Chain** for the name of the file.
- Click **Save**.

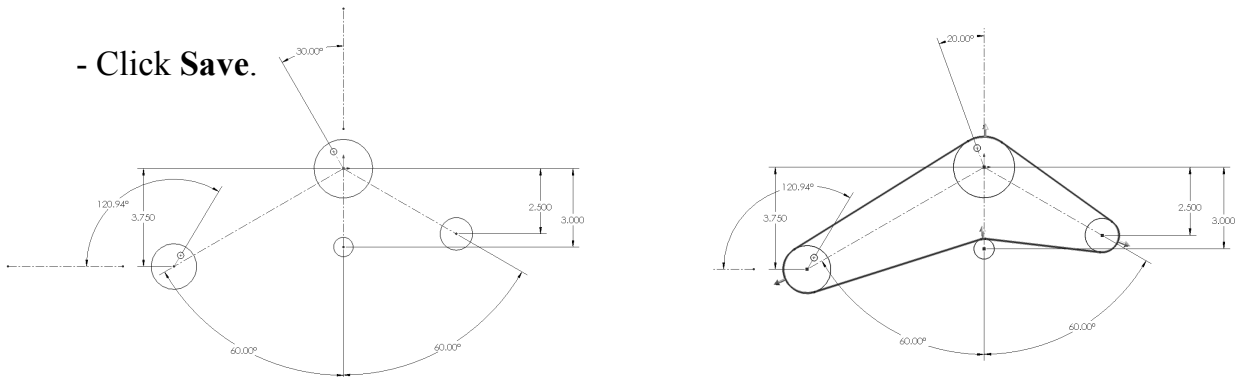

NOTE: Refer to the completed Belt Chain saved in the Training Files folder for reference, or to compare your results against it.

Exercise: Creating a Belt Chain

1. Creating the main sketch:

- Select the Front plane and open a new sketch.
- Sketch 3 circles approximately as shown and add dimensions to fully define the sketch.

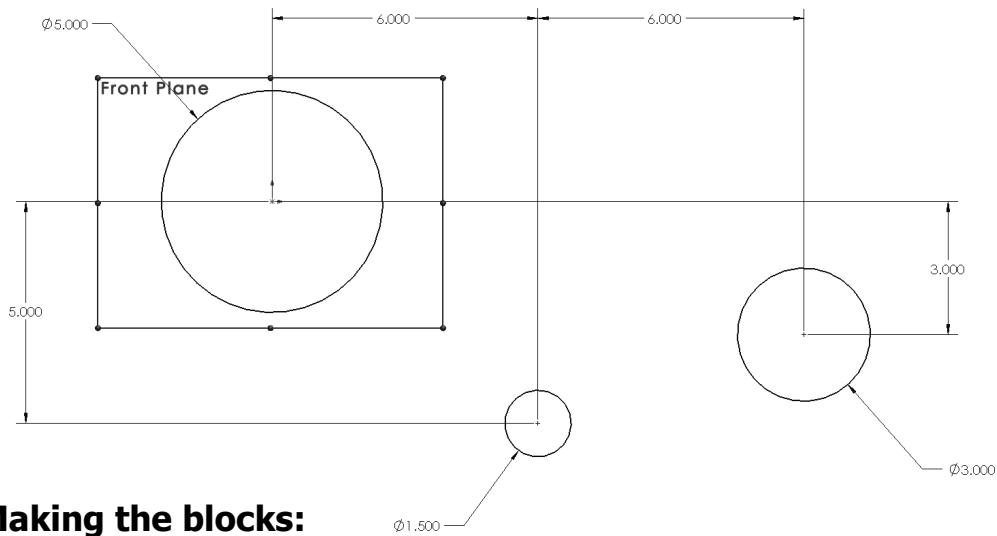
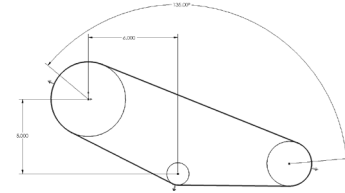

2. Making the blocks:

- Box-select the first circle on the left and click **Make Block** from the pop-up menu (arrow).
- The Make Block dialog appears on the left.
- Click **OK**.

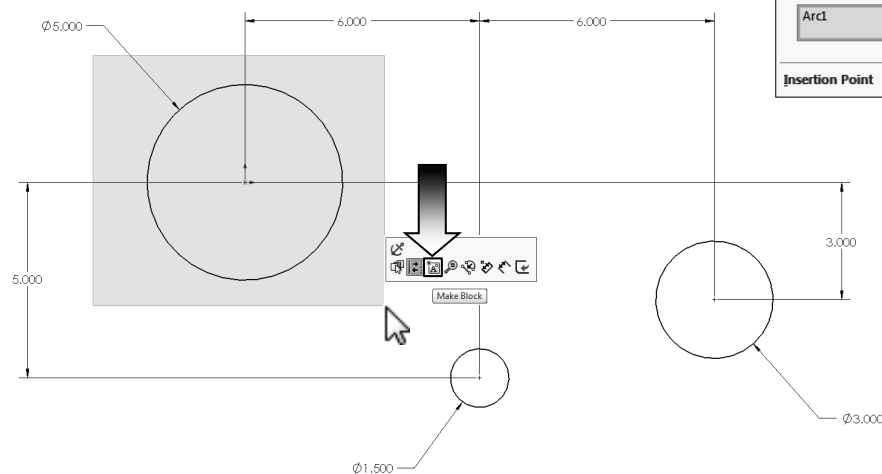

CSWE 2018 | Exam Preparation | Using Belt Chain

- Box-select the small circle in the middle and click the **Make Block** command once again.
- For this exercise, we will not need to create the Insertion Points for any of the blocks, since they will not need to be scaled or saved separately.
- Click **OK**.

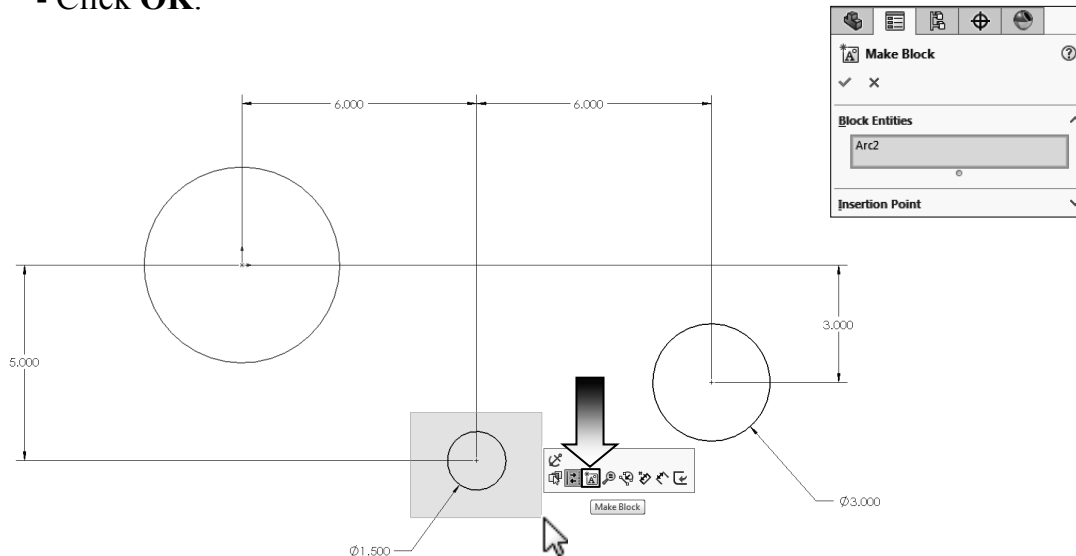

- Repeat the same step and make the 3rd block from the last circle.

NOTE: When making the blocks there is no order on which block you should make first or last; only when creating a Belt Chain you may have to follow a certain order to define the direction of the belt.

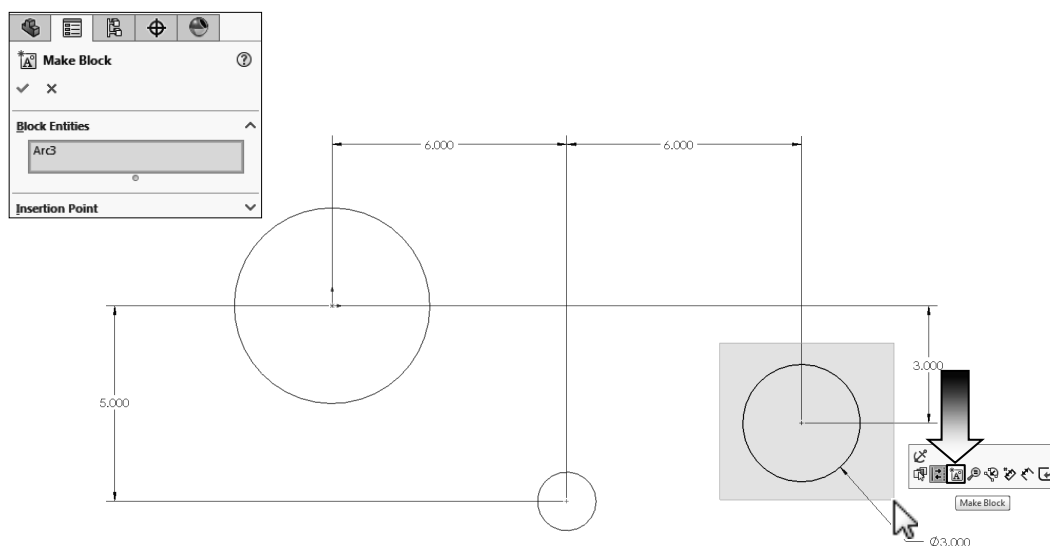

3. Creating the Belt Chain:

- From the Tools drop down menu, select **Sketch Entities / Belt Chain**.

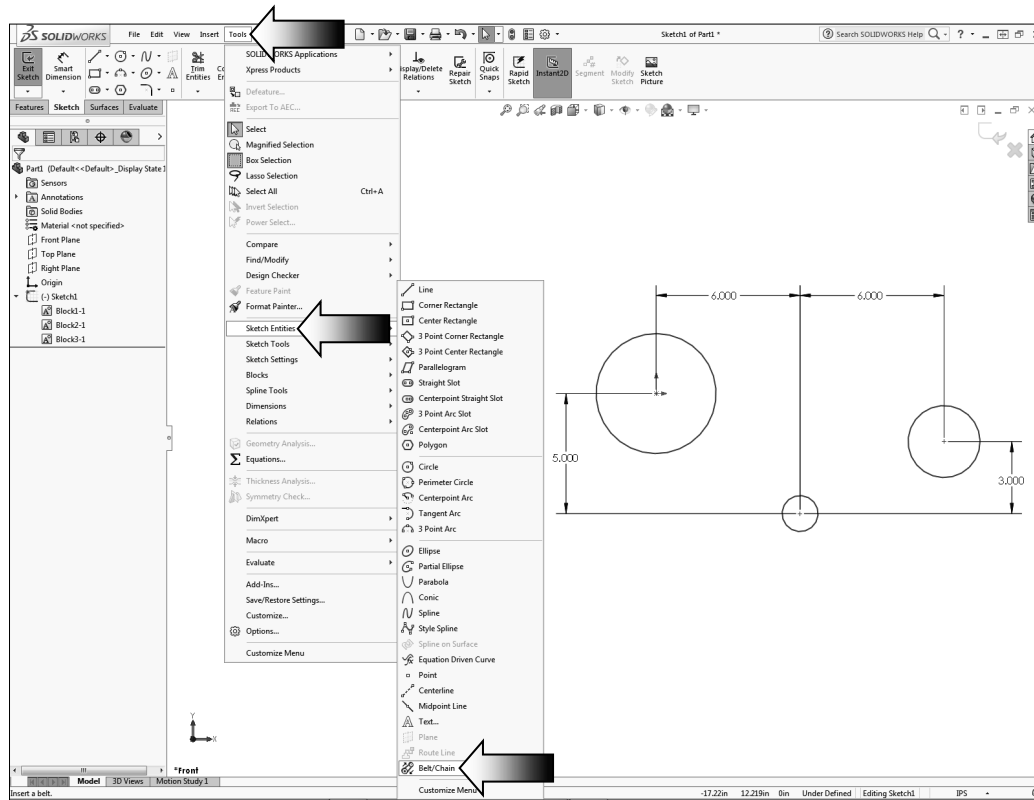

- Start the belt by clicking the largest circle on the left, then the smallest circle in the middle, and last, the one on the right.
- The preview of a belt appears along with the belt length.

- The current length of the belt is about **38.140in** (3 decimals).

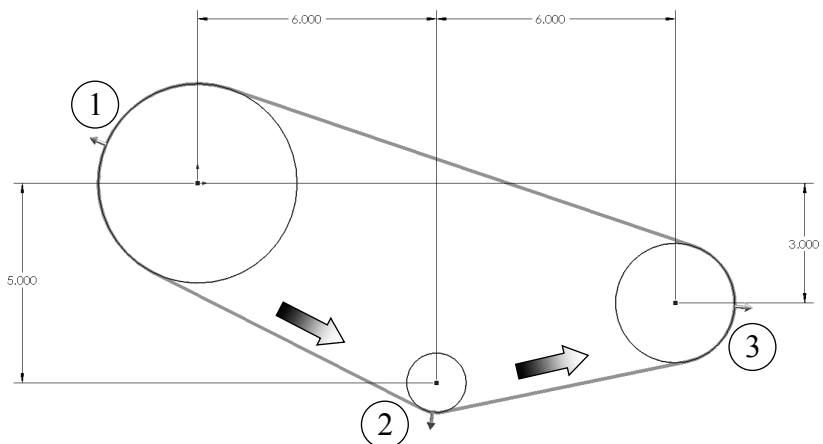
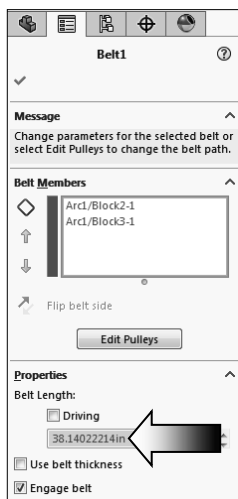

CSWE 2018 | Exam Preparation | Using Belt Chain

- Click **OK**.

- We are going to remove the 3.000 vertical dimension for now and later replace it with an angular dimension.

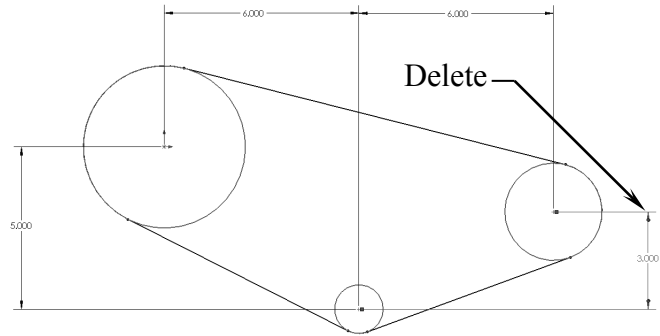

- The 2 lines on the right change to the blue color which indicates an under defined status.

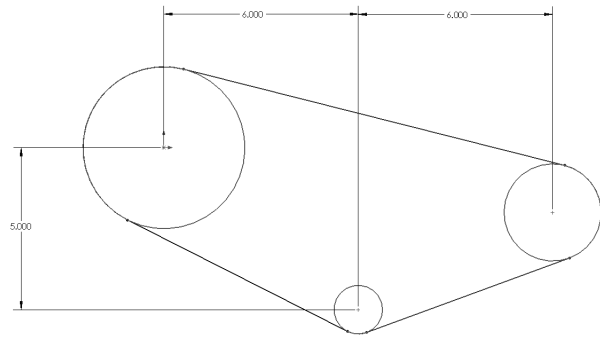

- Drag the center point of the largest circle away from the origin.

Drag the center to move it away from the origin

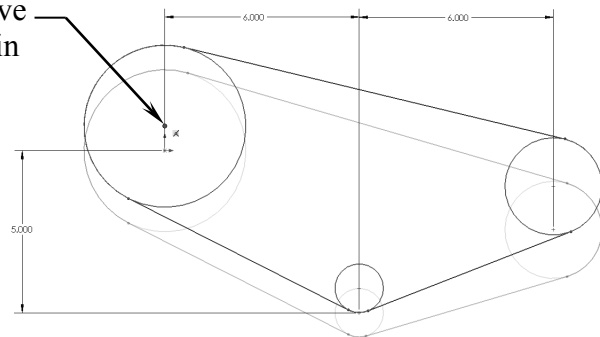

- Add a **Coincident** relation between the center of the large circle and the origin.

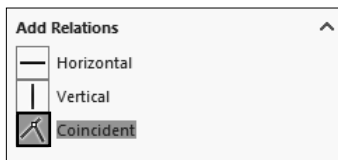

Add a Coincident relation

- Click **Rebuild**  to update the sketch.

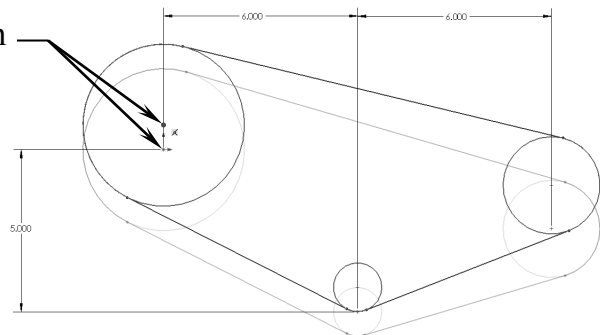
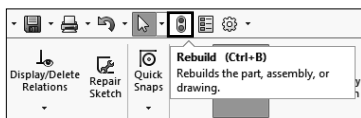

- Edit the Sketch1 from the FeatureManager tree.

- There should be three blocks tied to the Sketch1.

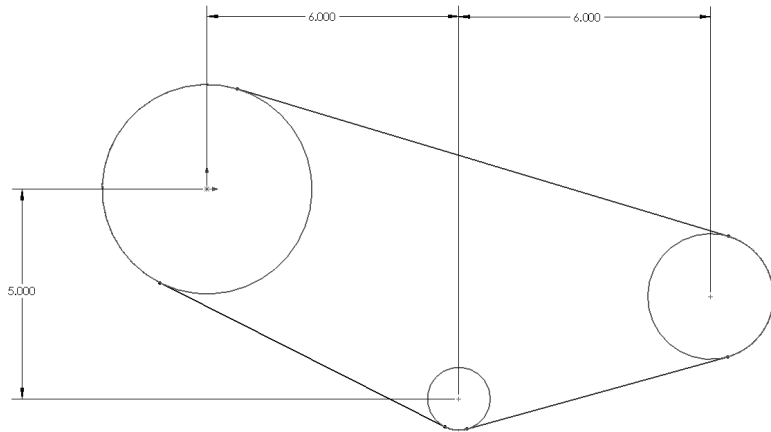
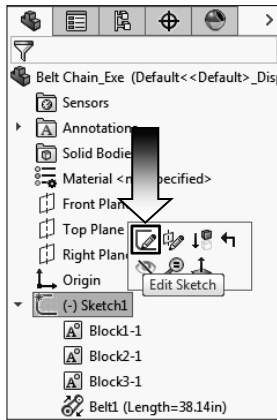

4. Adding an angular dimension:

- Select the **Smart Dimension** command and click the centers of the three circles in the order as labeled 1, 2, and 3 (clockwise direction).

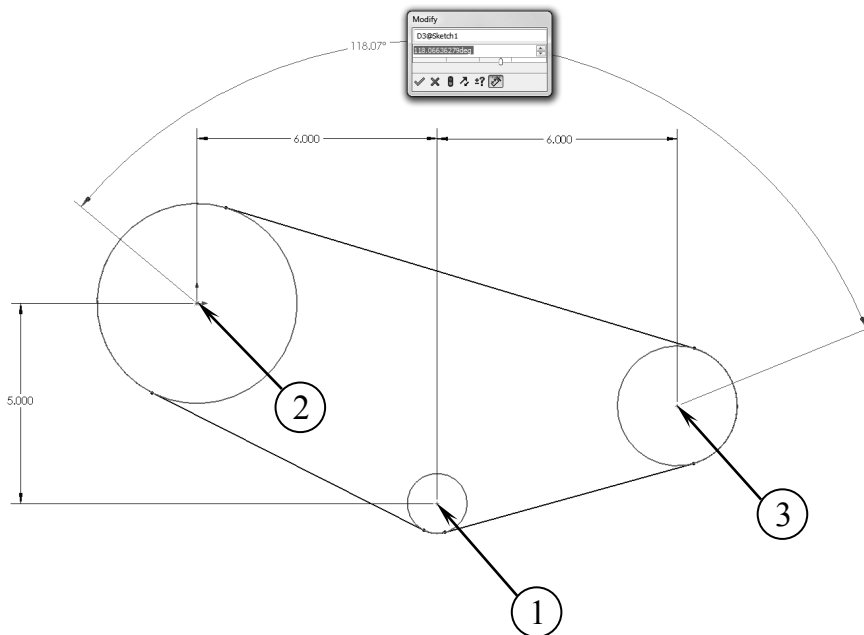

- Click **OK**.
- The default angle is about **115° to 122°**; we will change it in the next step.
- This angle also determines the length of the belt. Changing this angular dimension will also change the belt length.

5. Changing the angular dimension:

- Double click the Angular dimension and change its value to **135.00°**.
- Press the **Rebuild** button on the Modify box to execute the change.

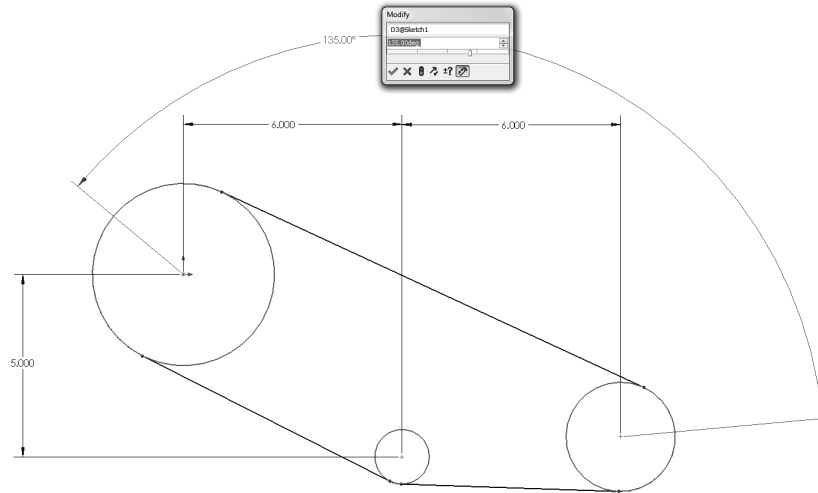

6. Verifying the belt length:

- **Edit** the Sketch1 from the Feature tree and double click the belt to edit it.
- The dimension change has updated the belt length to **38.556in**.

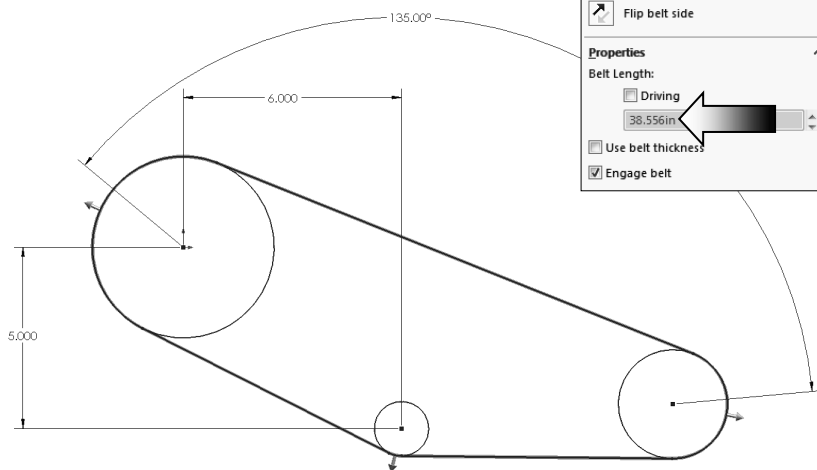
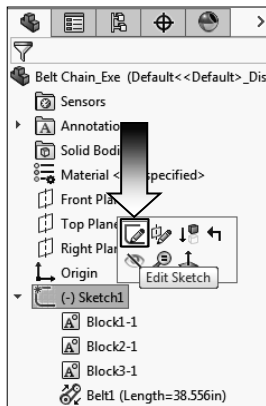

- Click **OK**.

7. Saving your work:

- Save your work as **Belt Chain_Exec**.
- Close all documents.