

SOLIDWORKS® 2018 Intermediate Skills

Expanding on Solids, Surfaces, Multibodies,
Configurations, Drawings, Sheet Metal
and Assemblies



Paul Tran CSWE, CSWI

Visit the following websites to learn more about this book:



[amazon.com](https://www.amazon.com)

[Google books](https://books.google.com)

[BARNES & NOBLE](https://www.barnesandnoble.com)

CHAPTER 2

Sketching

Sketching Handle

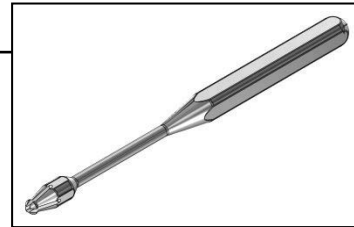

Most features in SOLIDWORKS start with a sketch. The sketch is the basis for a 3D model. You can create a sketch on any of the default planes (Front Plane, Top Plane, and Right Plane), or a created plane.

There are two modes for sketching in 2D: click-drag or click-click. The click-drag method will create a single entity each time but the click-click creates multiple, connecting lines.

While sketching the lines you can transition from sketching a line to sketching a tangent arc, and vice versa, without selecting the arc tool. Simply press the A key on the keyboard to switch from a line to a tangent arc – OR - start the line with the 1st click, move the pointer outward and back to the starting point, then away again.

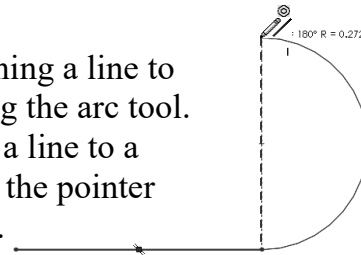

Inferencing lines are dotted lines that appear as you sketch, displaying relations between the pointer and existing sketch entities or model geometry. When your pointer approaches highlighted cues such as midpoints, the inferencing lines guide you relative to existing sketch entities.

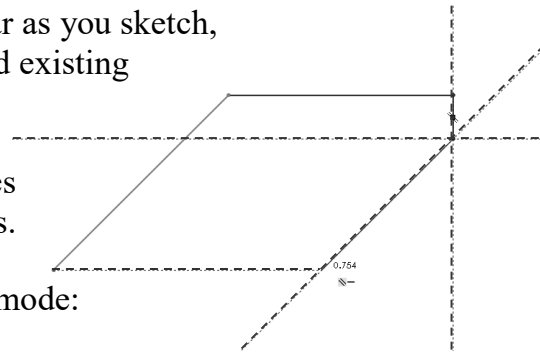

There are two types of Snaps in the sketch mode: Sketch Snap and Quick Snap.

Each Sketch Snap allows you to automatically snap to selected entities as you sketch. By default, all Sketch Snaps except Grid are enabled.

Quick Snaps are instantaneous, single operation Sketch Snaps. Sketching any sketch entity (such as a line) from start to finish is a single operation.

Sketching Handle

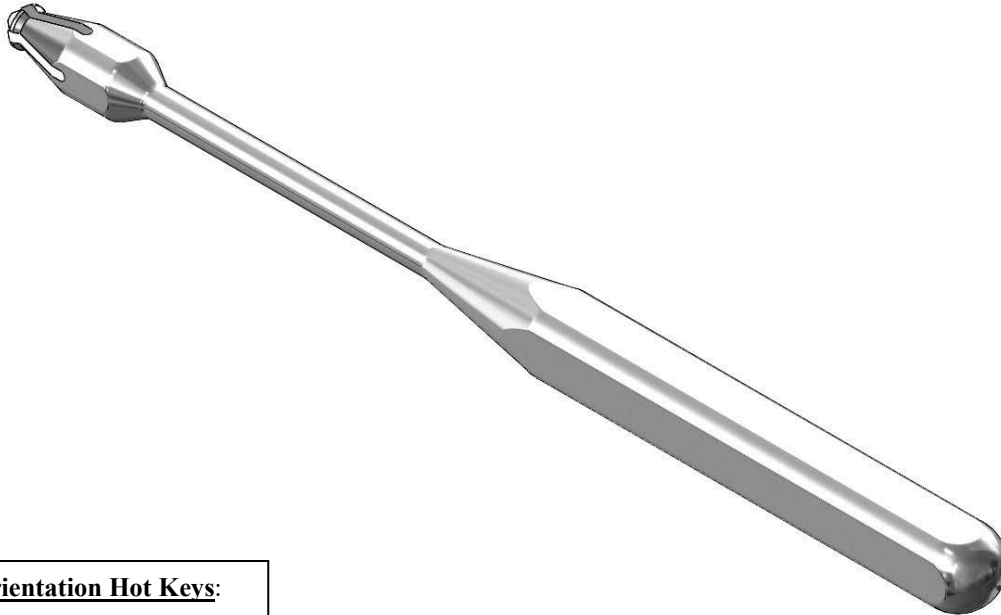

View Orientation Hot Keys:

Ctrl + 1 = Front View
Ctrl + 2 = Back View
Ctrl + 3 = Left View
Ctrl + 4 = Right View
Ctrl + 5 = Top View
Ctrl + 6 = Bottom View
Ctrl + 7 = Isometric View
Ctrl + 8 = Normal To Selection

Dimensioning Standards: **ANSI**

Units: **INCHES** – 3 Decimals

Tools Needed:



Insert Sketch



Line



Circle



Straight Slot



Centerline



Smart Dimension



Extruded Boss



Extruded Cut



Chamfer

1. Starting a new part document:

- Select **File / New**.
- The “Novice” dialog box by default is displaying three template options: **Part**, **Assembly**, and **Drawing**.
- Select the **Part** template and click **OK**.

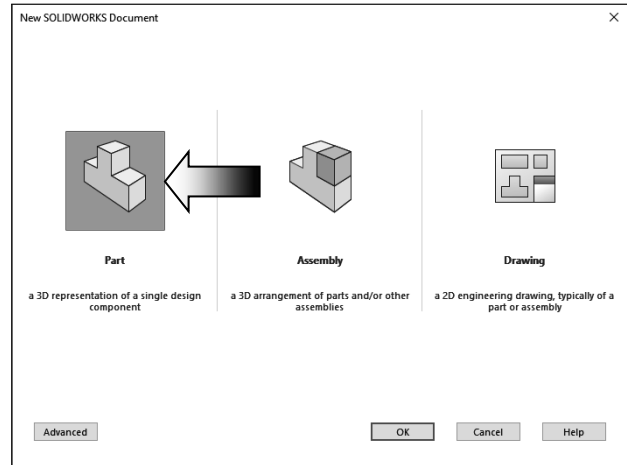

2. Changing the System Options:

- Click the small arrow  at the bottom right corner of the screen and select **IPS (Inch, Pound, Second)**.
- Select **Tools, Options**.

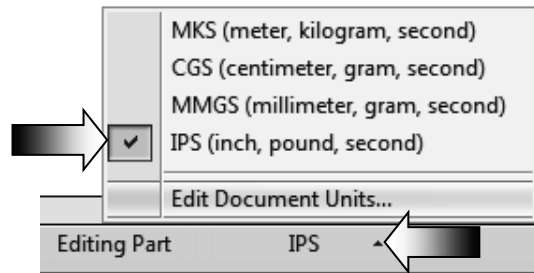

- Click the **Sketch** option.

- Enable the checkbox: **Auto-Rotate View Normal to Sketch plane on Sketch Creation**.

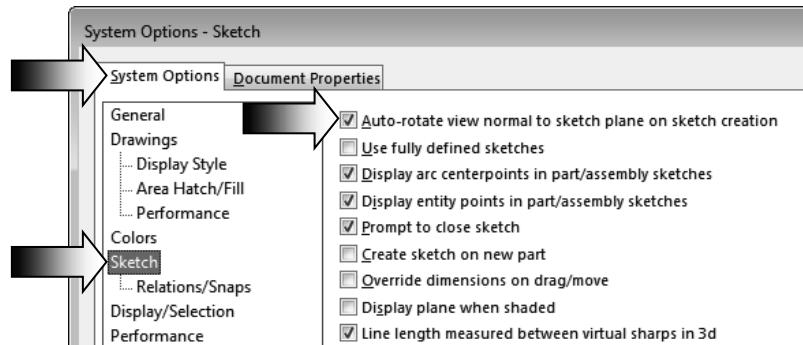

- Switch to the **Document Properties** tab.

- Click the **Drafting Standard** option and select the **ANSI** standard from the drop down list.

- Click **OK**.

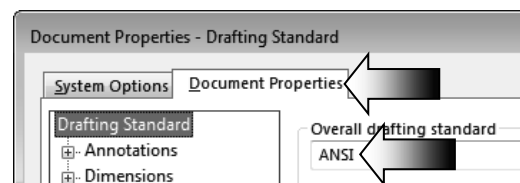

3. Creating the Parent sketch:

Sketching in SOLIDWORKS is the basis for creating features. Features are the basis for creating parts, which can be put together into assemblies. Sketch entities can also be added to drawings.

SOLIDWORKS sketch entities can snap to points (endpoint, midpoints, intersections, and so on) of other sketch entities. With Quick Snaps, you can filter the types of sketch snaps that are available.

Inferencing displays relations by means of dotted inferencing lines, pointer display, and highlighted cues such as endpoints and midpoints.

The sketch status appears in the window status bar. Colors indicate the state of individual sketch entities.

- The first sketch in a part document is considered the parent sketch.
- Select the **Front** plane and open a **new sketch** (arrow).

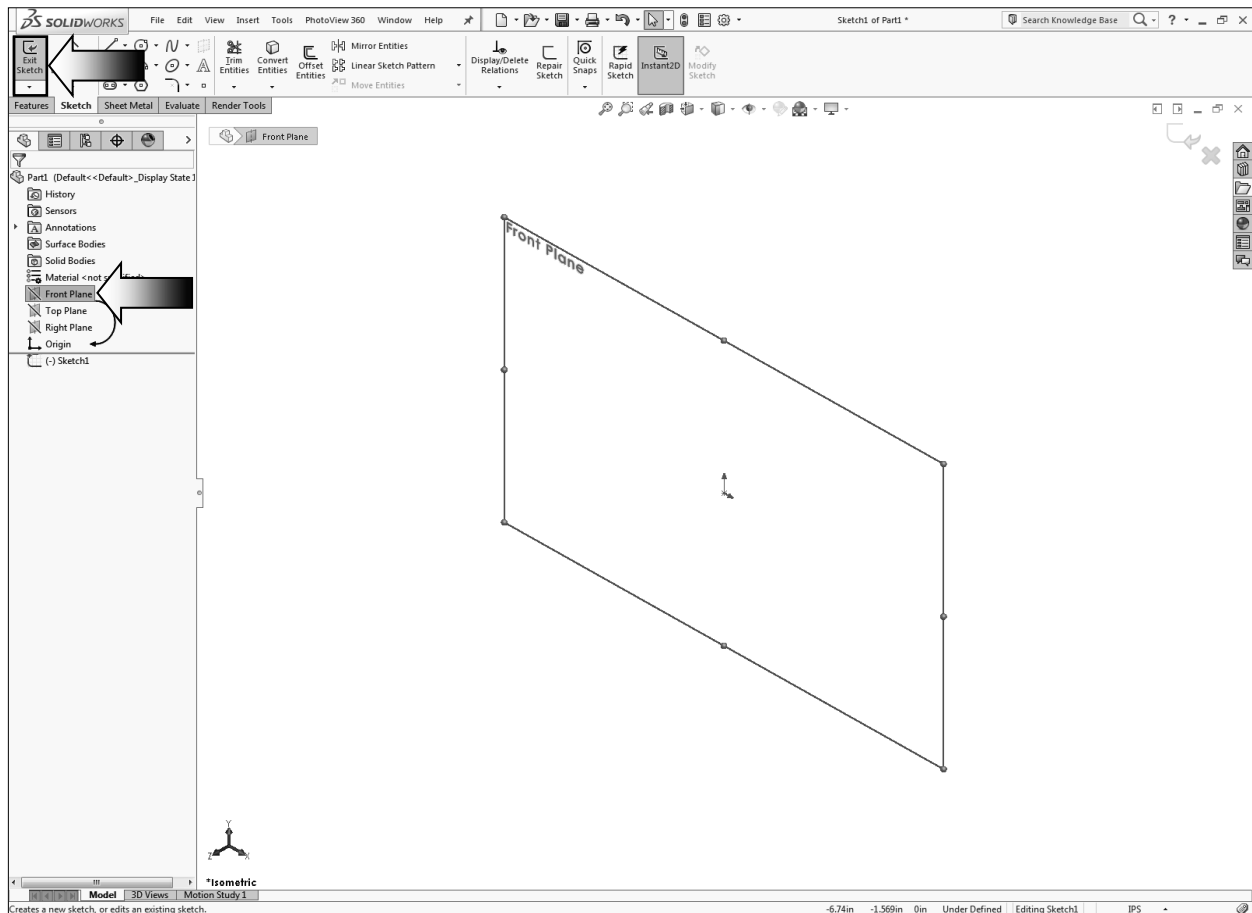

SOLIDWORKS 2018 | Intermediate Skills | Sketching

- Select the **Line** command  from the Sketch toolbar.

- Use the **Click + Click** method and start the first line at the Origin, move upward to make a vertical line, and then a horizontal line as indicated.



- Continue with sketching the rest of the lines as shown below.

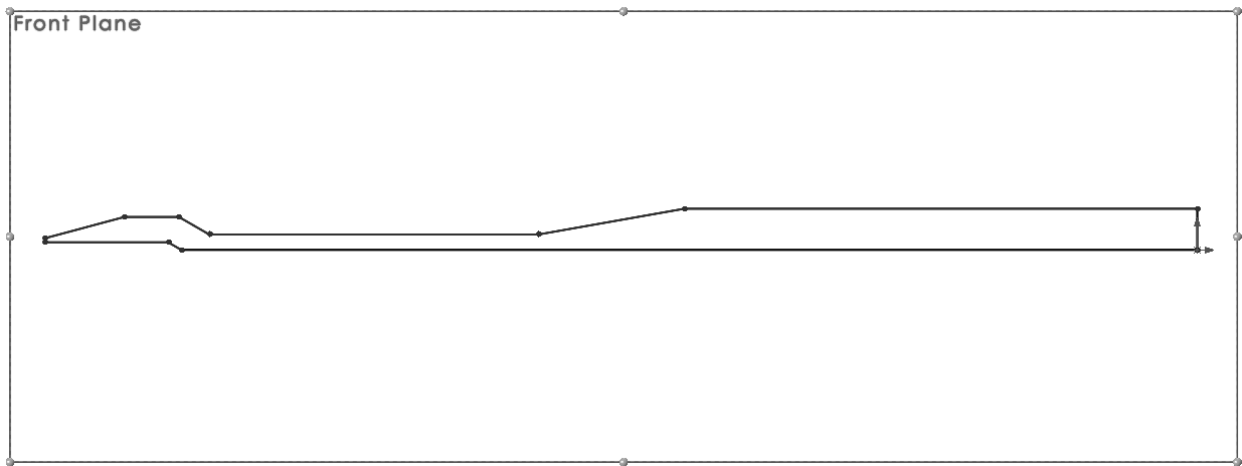

- Select the **Smart Dimension** command ; add the dimensions shown 

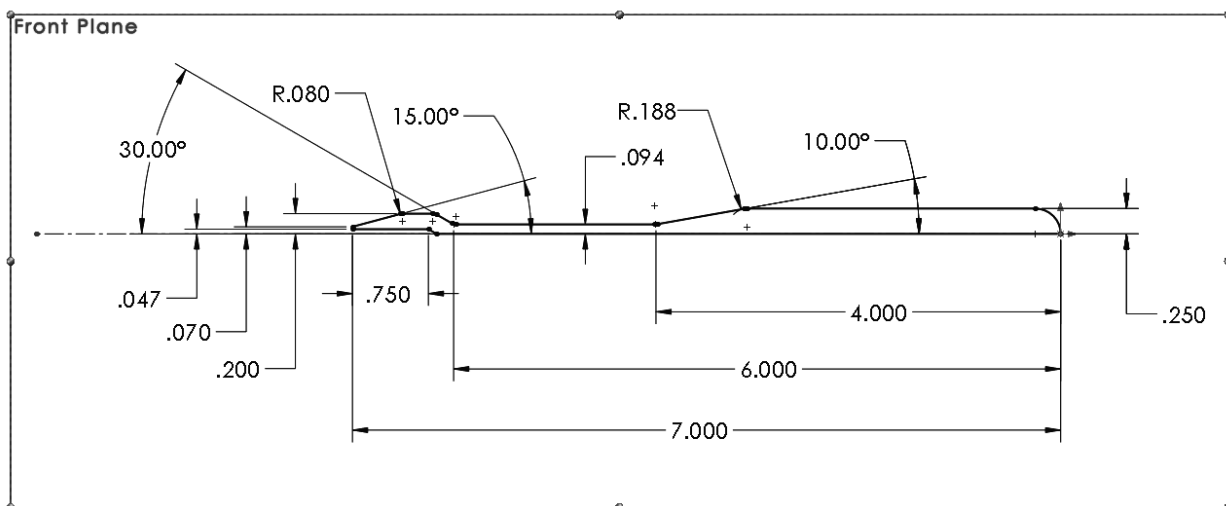

SOLIDWORKS 2018 | Intermediate Skills | Sketching

- It is better to add the Sketch Fillets after the sketch is fully defined.
- Add the dimensions to the left end of the sketch as indicated below.

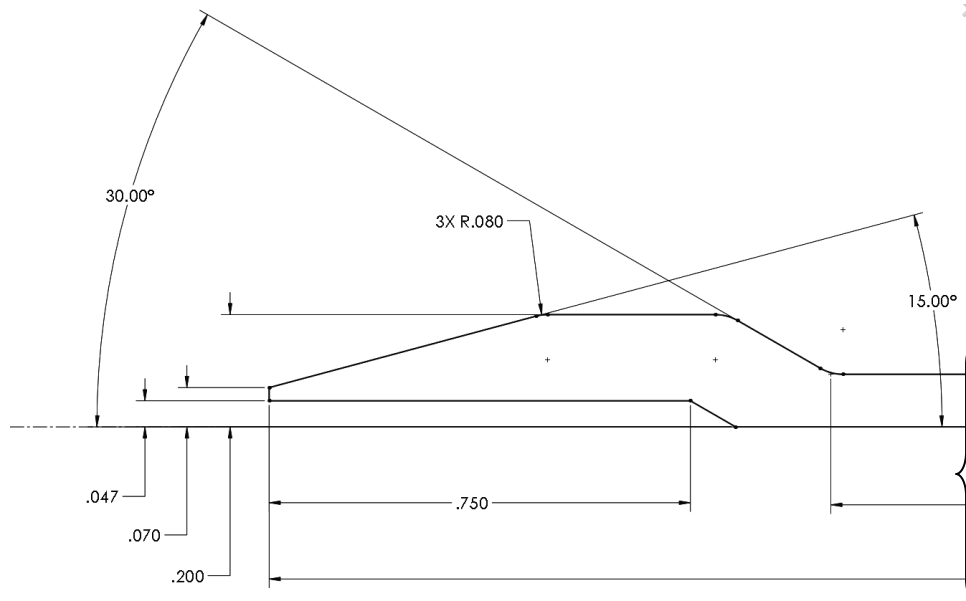

Left end of the sketch

- Add the dimensions to the right end of the sketch as shown.
- The dimension R.250 is a reference dimension and shown in gray color.

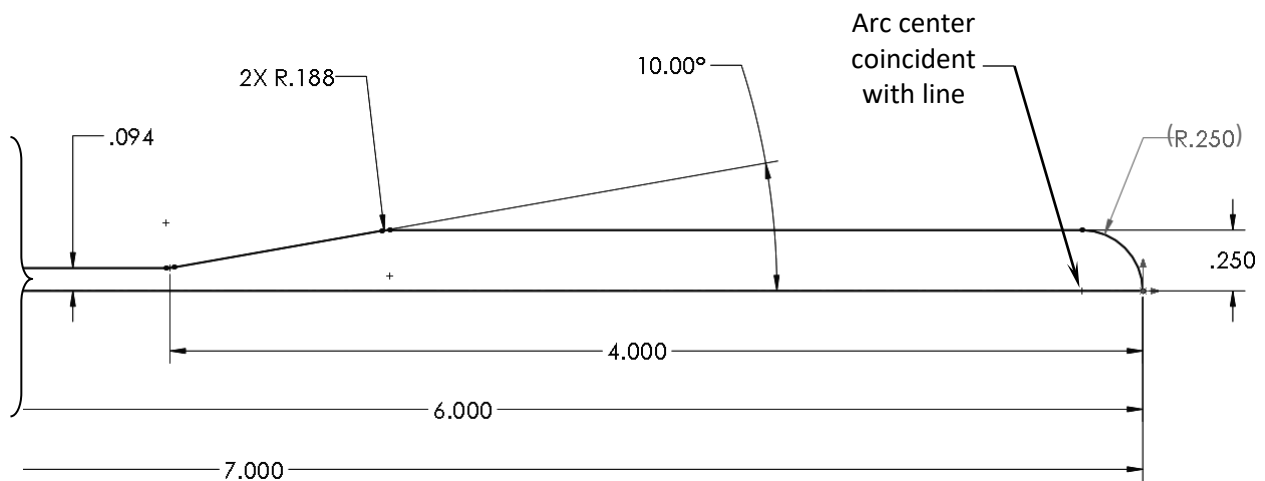

Right end of the sketch

4. Revolving the parent sketch:

- Switch to the **Features** tool tab.
- Select the revolved **Boss/Base** command.
- Use the default **Blind** type and **360°** angle.
- Click **OK**.

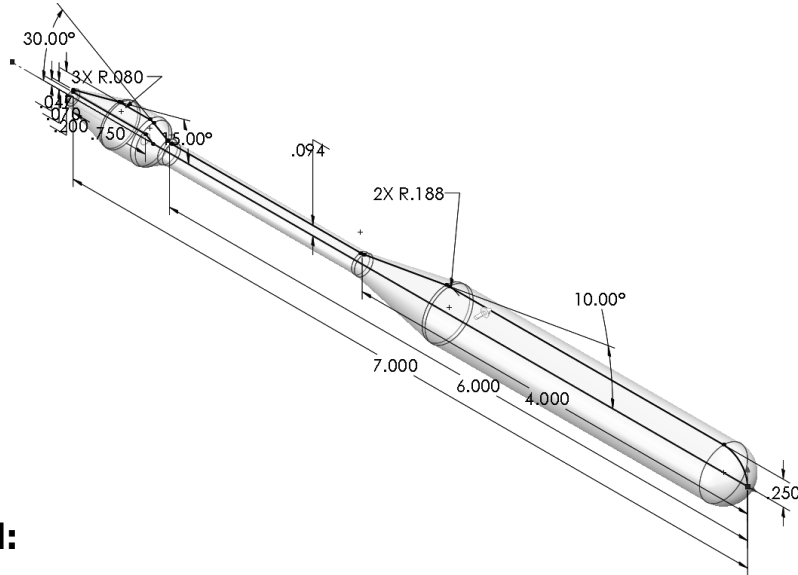
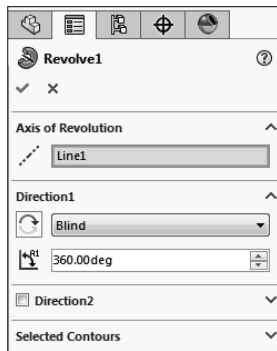
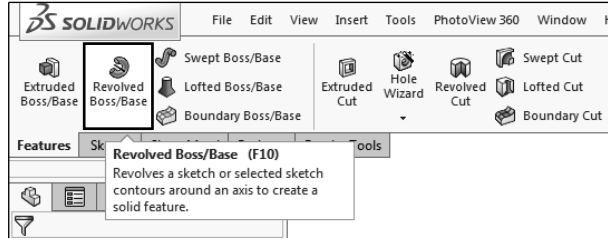

5. Adding the tip detail:

- Select the **Top** plane and open a new sketch.

- Sketch the profile shown on the right.

- Sketch a horizontal centerline to use as the revolve line.

- Add the relations and the dimensions as indicated.

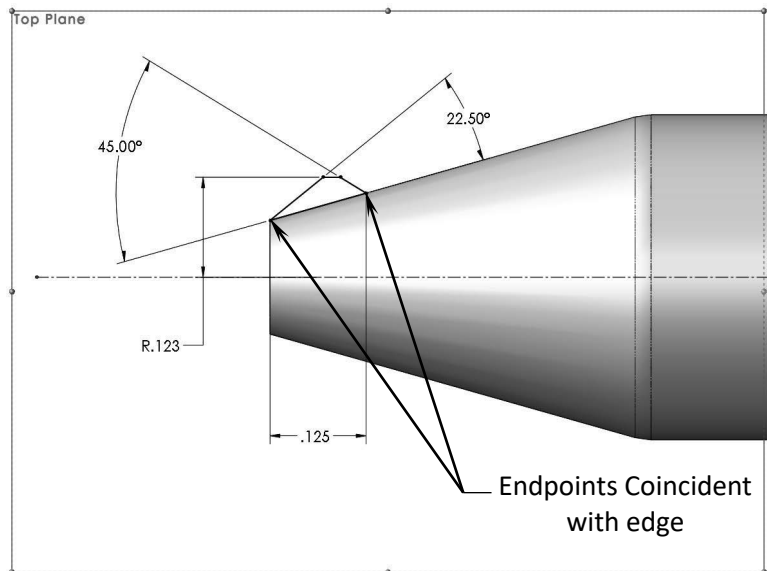

- Be sure to fully define the sketch before revolving it.

6. Revolving the sketch:

- Select **Revolved Boss/Base**.

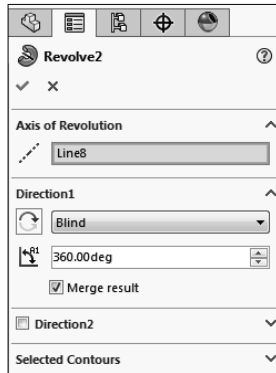

- Use the default **Blind** type.

- Revolved Angle **360°**.

- Click **OK**.

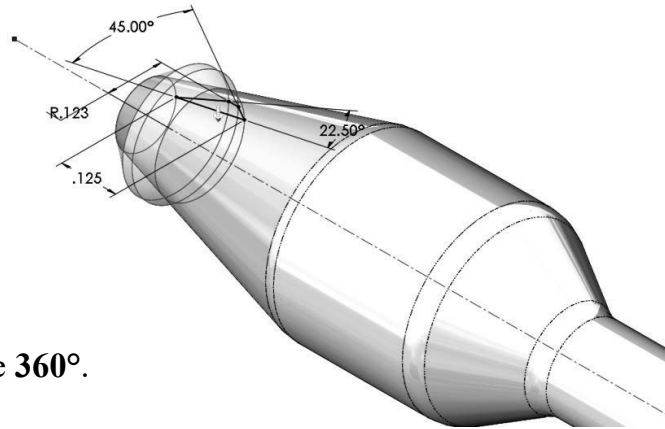

7. Transitioning from Line-to-Arc:

- Select the **Top** plane and open a new sketch.

- Use the **click-click** method and sketch a short vertical line and a horizontal line starting at the midpoint on the left side.

- To change from a line to a Tangent Arc first move the cursor outward as shown then push the **A** key on the keyboard; the tangent arc appears.

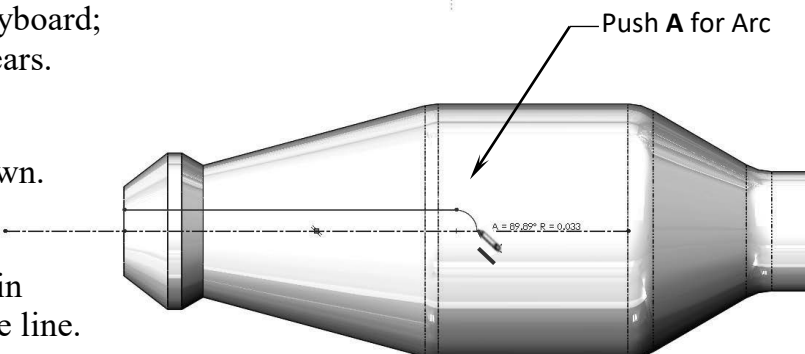
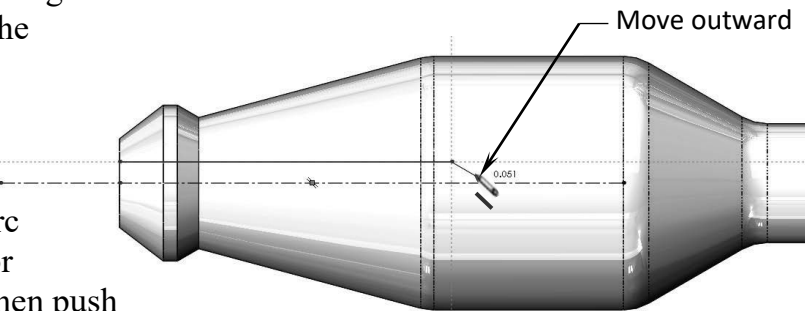
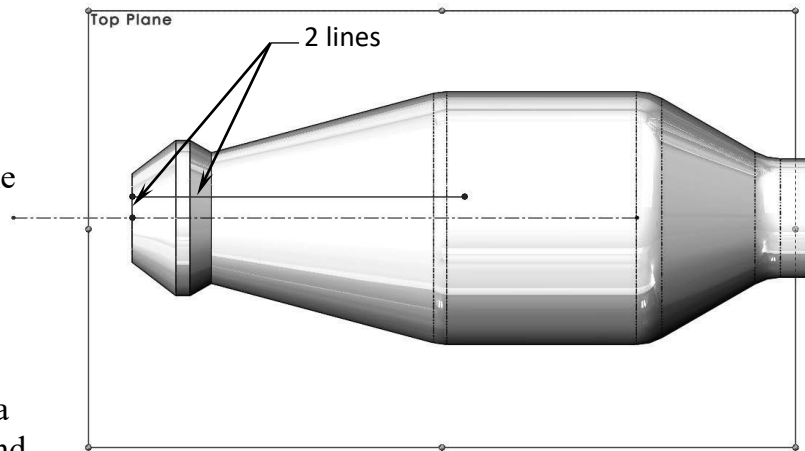

- Make an arc as shown.

- Push the **A** key again to switch back to the line.



8. Mirroring in sketch mode:

- Push **Esc** to exit the line command.
- **Box-Select** all sketch entities and click the **Mirror Entities** command.

 **Mirror Entities** 

Mirrors selected entities about a centerline, a line, or a model edge.
A Symmetric relation is added to each mirrored entity.

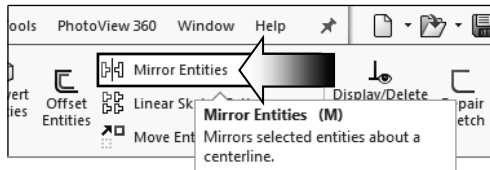

- All selected entities are mirrored about the horizontal centerline.

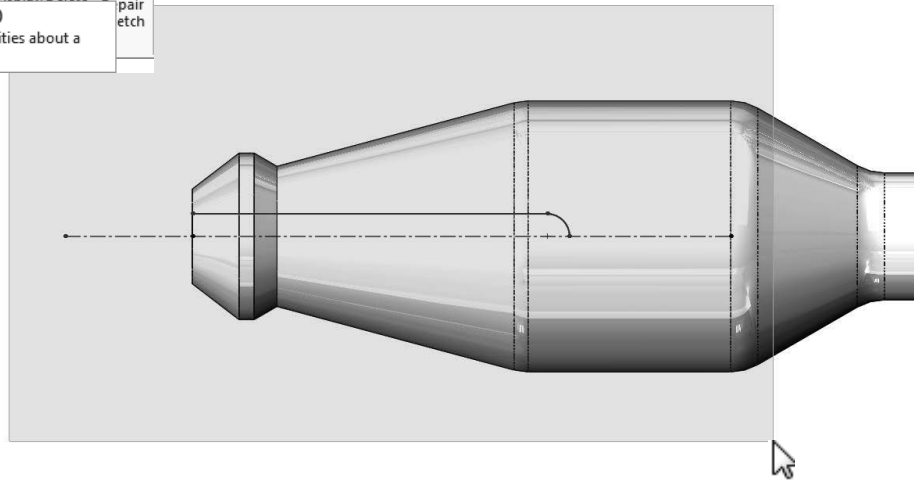

- A **Symmetric** relation is added to each mirrored entity.

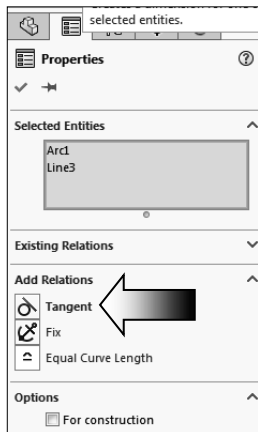
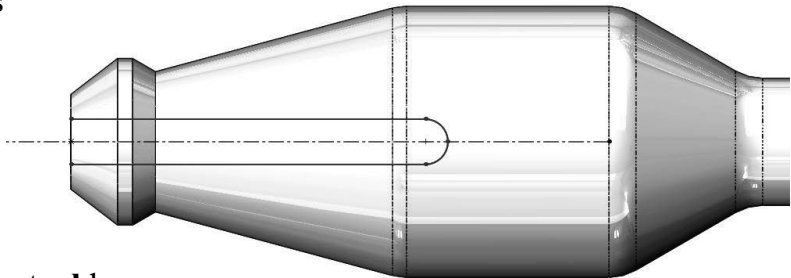

- Hold the **Control** key and select the 2 arcs; click the **Tangent** relation (arrow).

Add a Tangent relation to 2 arcs

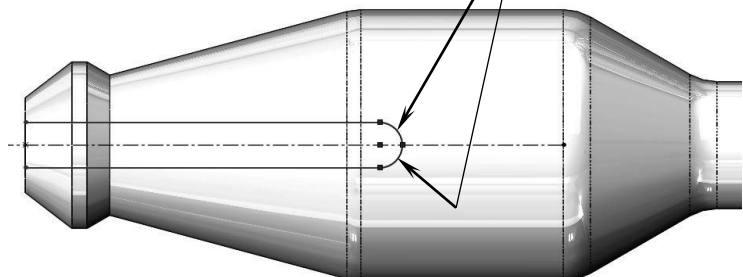

- Click **OK**.

9. Adding dimensions:

- Use Smart Dimension tool to specify the size and location for each sketch entity.

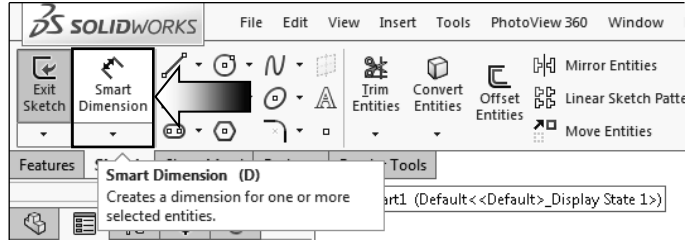

- The sketch entities appear in blue color when they are not yet constrained, but turn black when relations or dimensions are added.

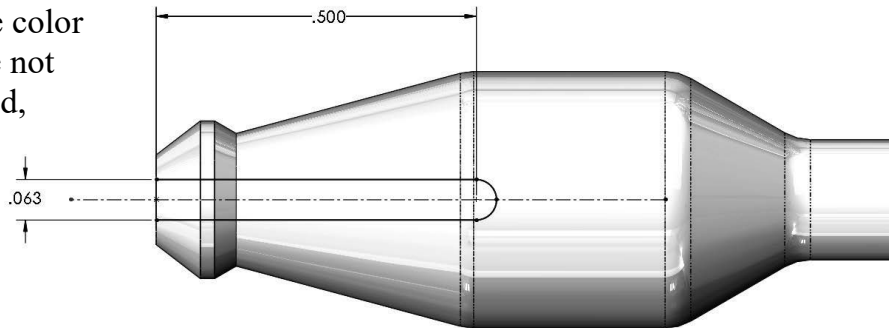

- Add the two dimensions shown.
- The Status of the sketch is displayed at the lower right corner of the screen.

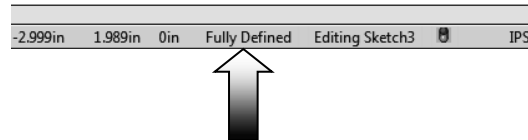

10. Extruding a cut:

- Switch to the Features tool tab and click **Extruded Cut**.
- Select the **Through All** condition from the list and click **Reverse** direction.
- Click **OK**.

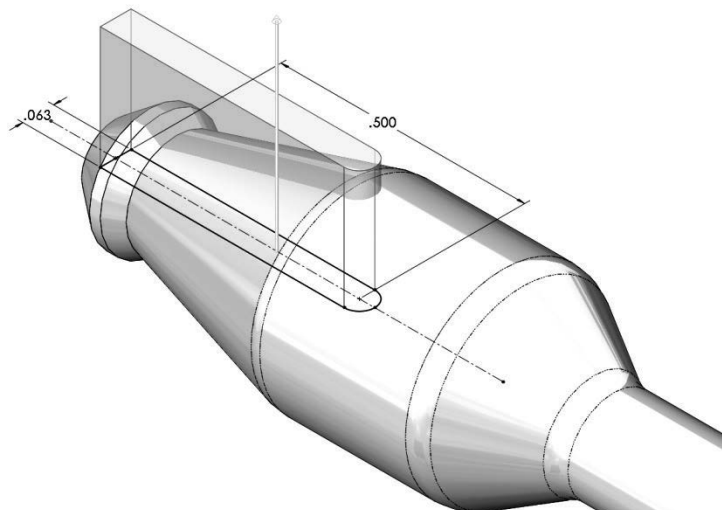
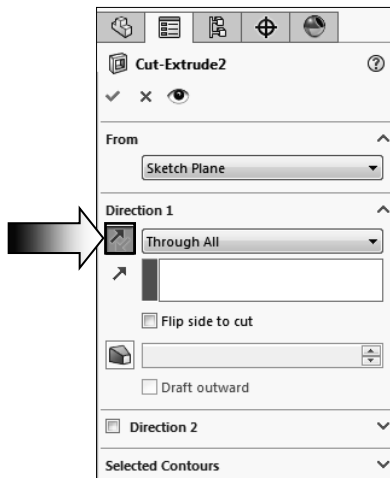

11. Creating a Circular Pattern:

- Circular patterns create multiple instances of one or more features and space them uniformly around an axis.

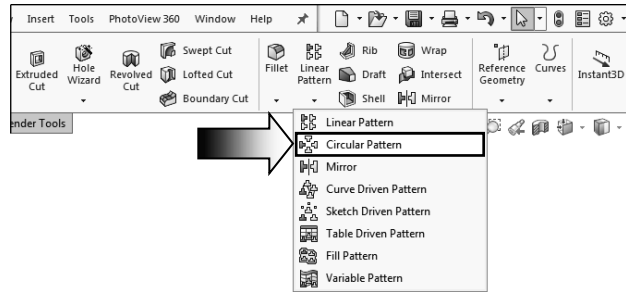

- Select the **Circular Pattern** command below the Linear Pattern drop down list.

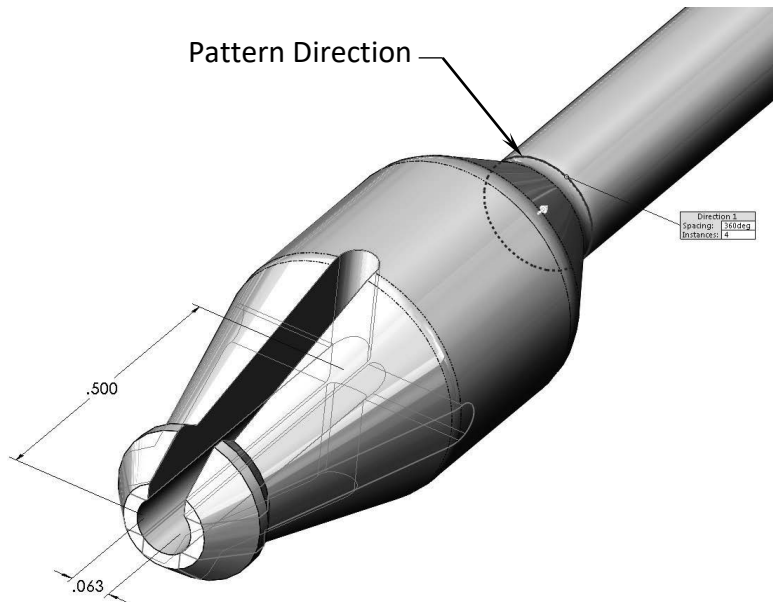
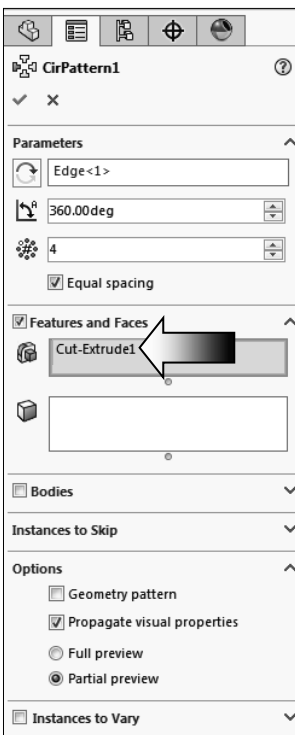

- For Pattern Direction, select one of the **circular edges** in the model.
- Enable the **Equal Spacing** checkbox (arrow).
- Enter **4** for Number of Instances.
- Select the **Cut-Extrude1** either from the Feature tree or from the graphics area. The preview graphics of the four instances appears.
- Click **OK**.

12. Adding other cut features:

- The flat features not only provide better grips but also help keep the device from rolling around.
- Select the **Top** plane and open a new sketch.
- Sketch **2 Corner Rectangles** at both ends of the model.

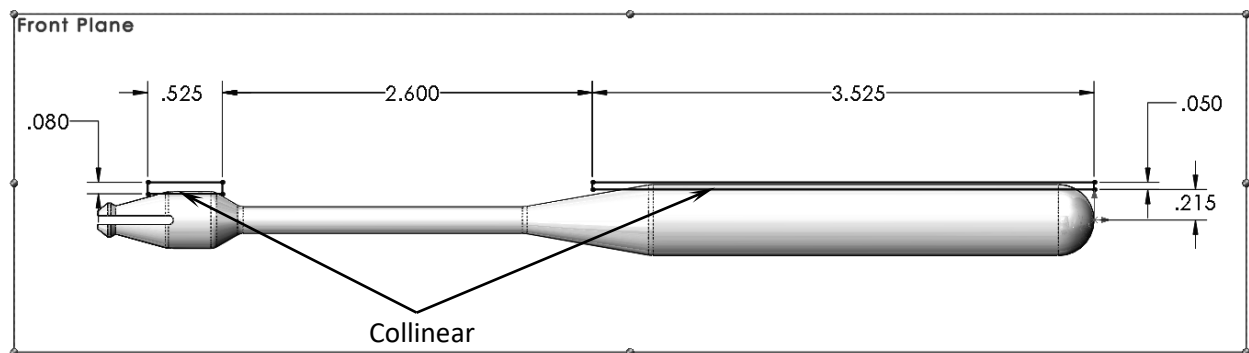

- Add the dimensions and relations shown to fully define the sketch.



Left end of the sketch

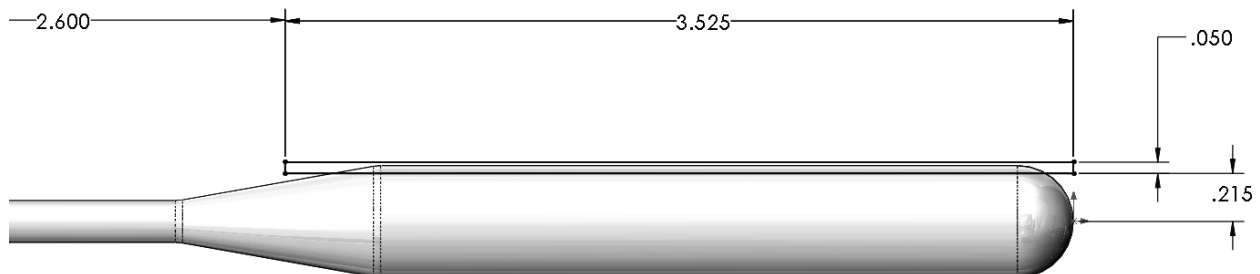

Right end of the sketch

SOLIDWORKS 2018 | Intermediate Skills | Sketching

- Switch to the **Features** tool tab and click the **Extruded Cut** command.
- Select the **Through All – Both** from the list to cut through both directions.

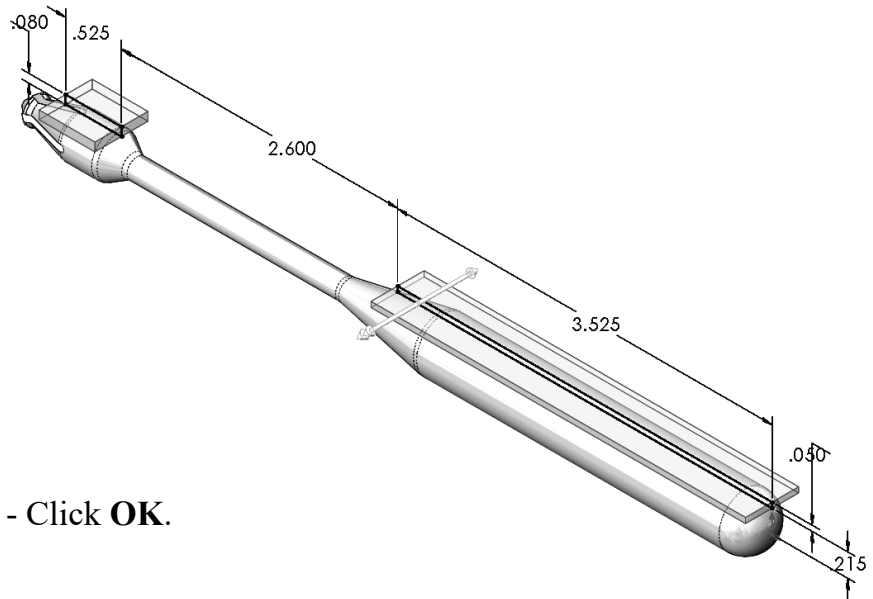
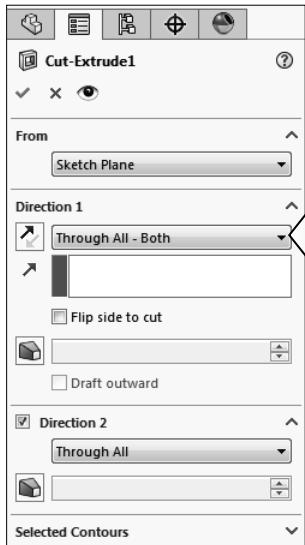

- Click **OK**.

13. Creating another Circular Pattern:

- Select the **Circular Pattern** command below the Linear Pattern option.
- For Pattern Direction, select one of the **circular edges** of the model.

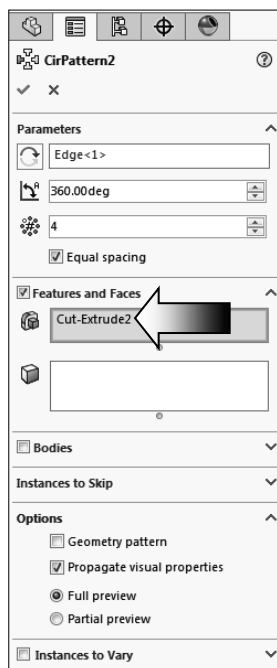

- Enable the **Equal Spacing** checkbox.

- Enter **4** for Number of Instances.

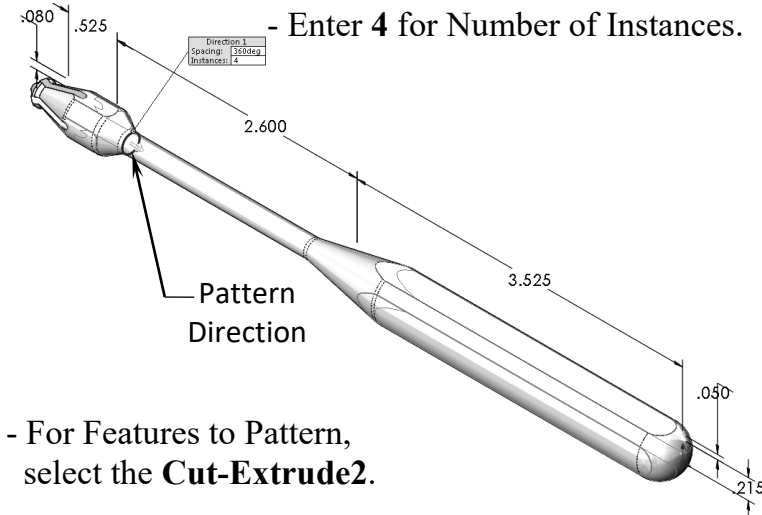

Pattern
Direction

- For Features to Pattern,
select the **Cut-Extrude2**.

- Click **OK**.

14. Adding a .032" Constant Size Fillet:

- Select the **Fillet** command  from the Features tool tab.

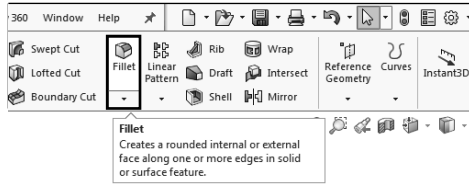

 **Constant Size Fillet**

Creates fillets that have a constant size for the entire length of the fillet.

- The **Constant Size Radius** is the default type.
- Select one edge for each flat feature, for a total of **8 edges**.

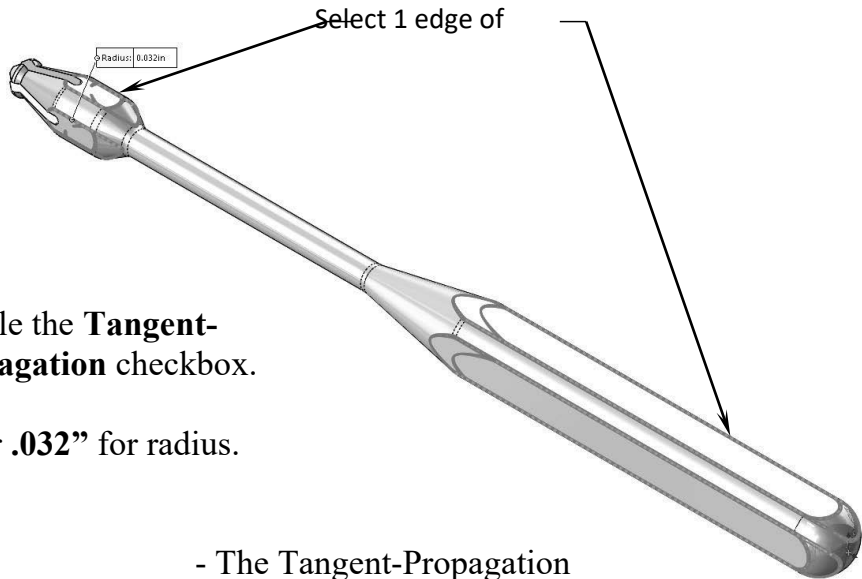
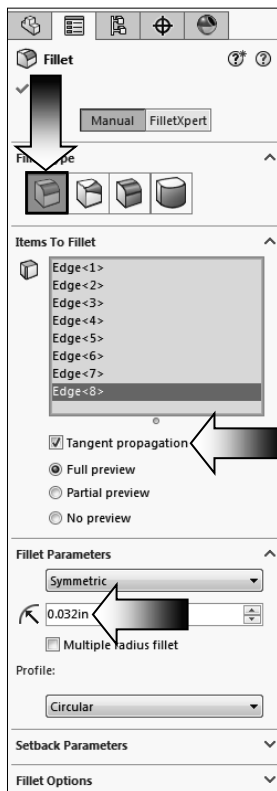

- Enable the **Tangent-Propagation** checkbox.
- Enter **.032"** for radius.

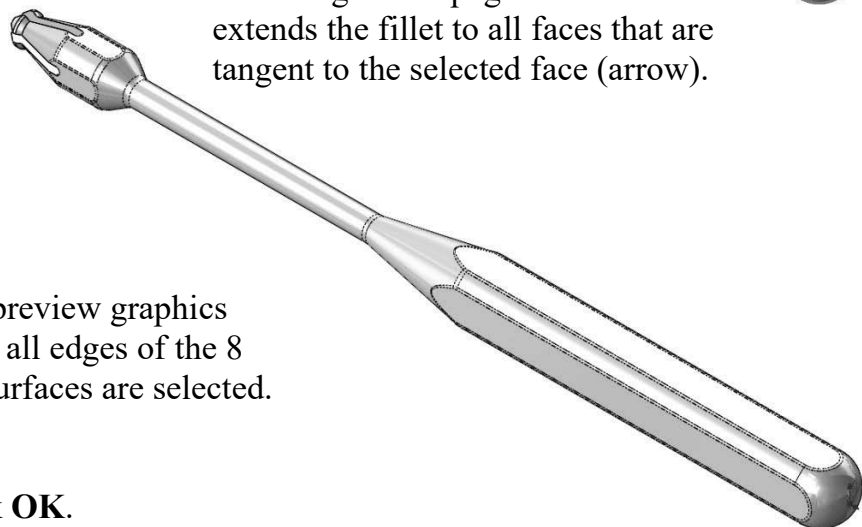

- The **Tangent-Propagation** extends the fillet to all faces that are tangent to the selected face (arrow).
- The preview graphics show all edges of the 8 flat surfaces are selected.
- Click **OK**.

15. Assigning material to the model:

- SOLIDWORKS has two sets of properties, visual and physical (mechanical). The response of a part when loads are applied to it depends on the material assigned.
- Right click **Material** on the FeatureManager tree and select **Edit Material**.
- In the SOLIDWORKS Materials folder, expand the **Steel** sub folder.

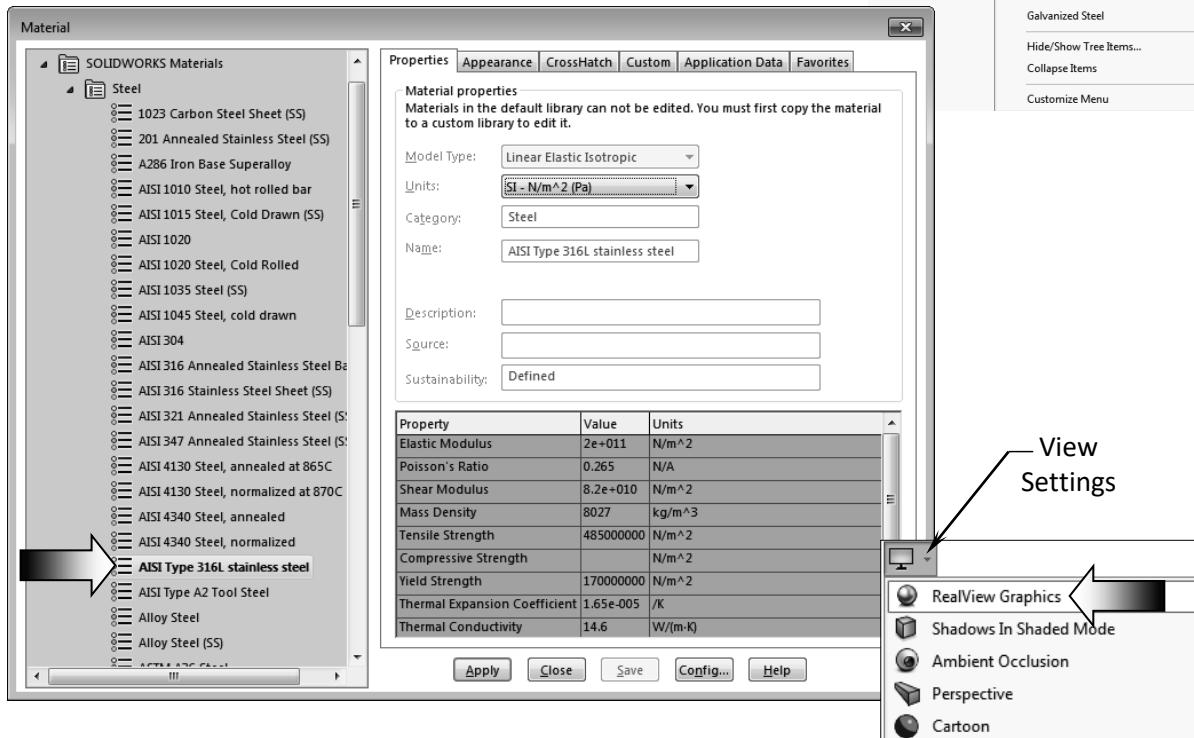
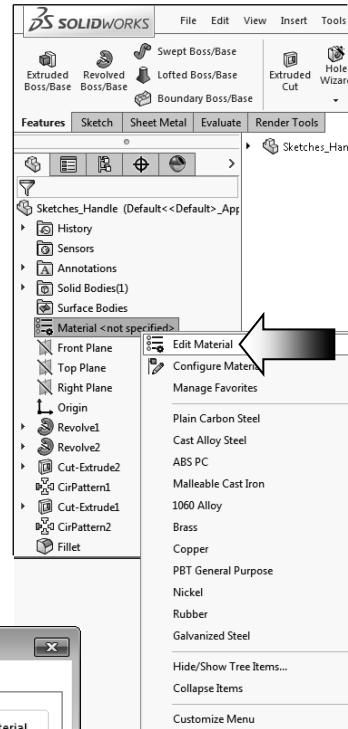

- Select the material **AISI Type 316L Stainless Steel** from the list (arrow).
- Click **Apply** and **Close**.
- Enable the **RealView Graphics** option (under View Settings) to enhance the model display if applicable.

16. Calculating the Mass of the model:

- Switch to the **Evaluate** tab.
- Click the **Mass Properties** command (arrow).

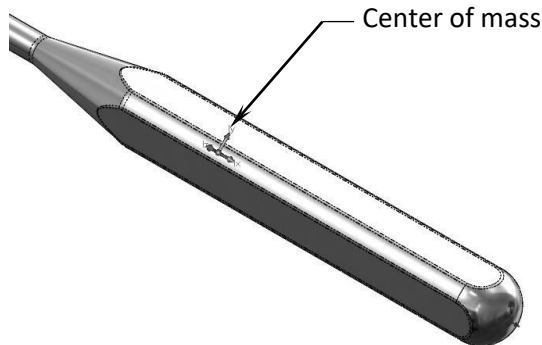
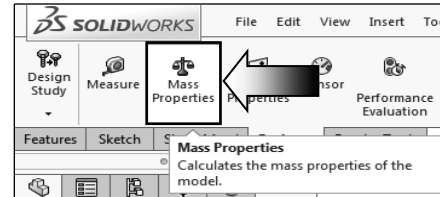

- In the graphics area, a single-colored triad indicates the principal axes and center of mass of the model.
- The mass of the model based on the selected material is **.212 pounds**.

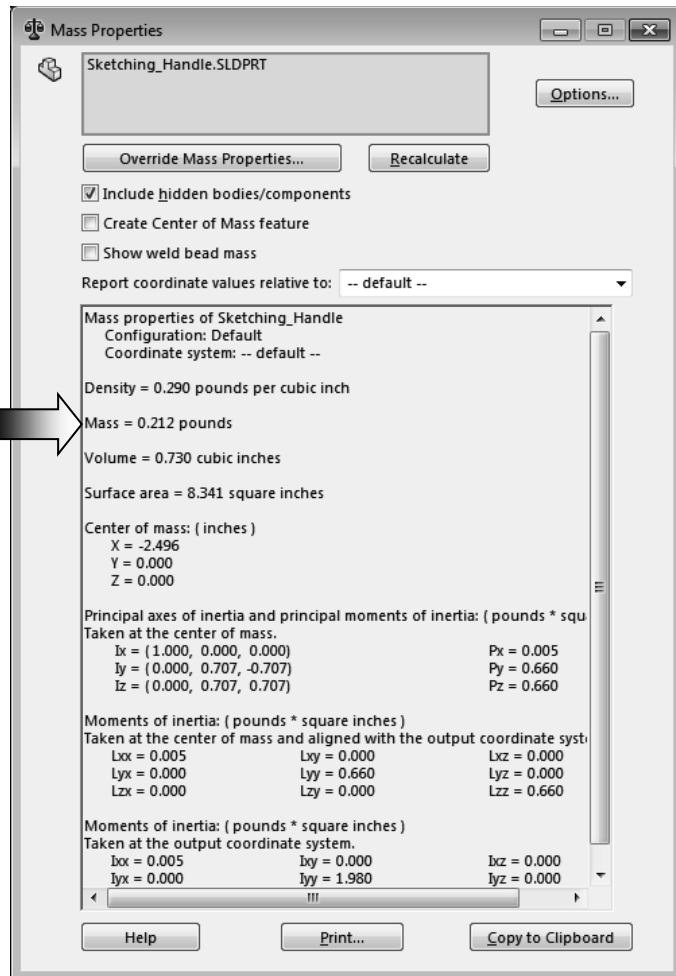

17. Saving your work:

- Select File / Save As.
- Enter **Sketching_Handle.sldprt** for the name of the part.
- Click **Save**.

Working with Sketch Pictures

Working with Sketch Pictures

Pictures and images that were saved as one of the file formats supported by the Windows operating system can be inserted into SOLIDWORKS, and used as an underlay for creating 2D sketches (raster data to vector data).



The supported formats are .jpg, .tif, .bmp, .gif, .png, .wmf, and .psd. The source image should be hi-resolution, with a minimum of 300dpi. The line art should be pen on paper (not pencil), and with precise contours and high contrast. The current supported resolution is limited to 4096 x 4096.

There are a few things to keep in mind when working with sketch pictures:

- The picture will be embedded in the document, but if the original image is changed, the sketch picture will not update.
- If you sketch over the picture, there is no snap to picture, inferencing, or auto tracing capability. If the image is moved, or deleted and replaced, the sketch will not update. And if the sketch is hidden, the picture will be hidden as well.

If the sketch or the picture becomes inactive, simply double-click the picture to reactivate it. The values in the PropertyManager allow the picture to be moved, rotated, or scaled either proportionally or un-proportionally.

There is an Auto-Trace option in SOLIDWORKS Add-Ins, but it only works well if the image's outline is sharp and the background is clear or clear. This lesson discusses a different approach, where a jpeg file gets converted to a SOLIDWORKS 2D sketch, by tracing its outline with the sketch tools, and then revolves it into a 3D model.

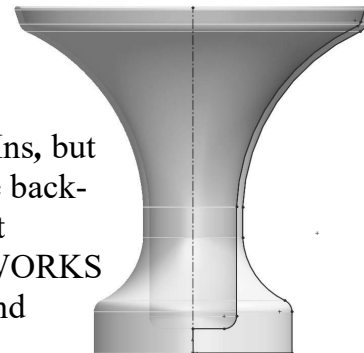

Working with Sketch Pictures



Dimensioning Standards: **ANSI**

Units: **INCHES** – 3 Decimals

Tools Needed:



Insert Sketch



Sketch Picture



Centerline



Line



Tangent Arc



Sketch Fillet



Dimension



Revolve
Boss/Base

1. Starting with a layout sketch:

- Most of the time, a sketch picture will get inserted into SOLIDWORKS with a wrong size or scale. It would be quite helpful to have an overall full-size construction box laid out ahead of time, to use as a guide to scale the picture.

NOTE: *There will be no links or snaps between the layout sketch and the picture. If the sketch is moved or changed, the picture will not update.*

- Click **File / New / Part**. Set the Units to **IPS**, 3 decimals. Select the **Front** plane and open a new sketch.
- Sketch eight centerlines and add the dimensions as shown below to fully define the sketch. The centerlines will be used to help scale the image to size.

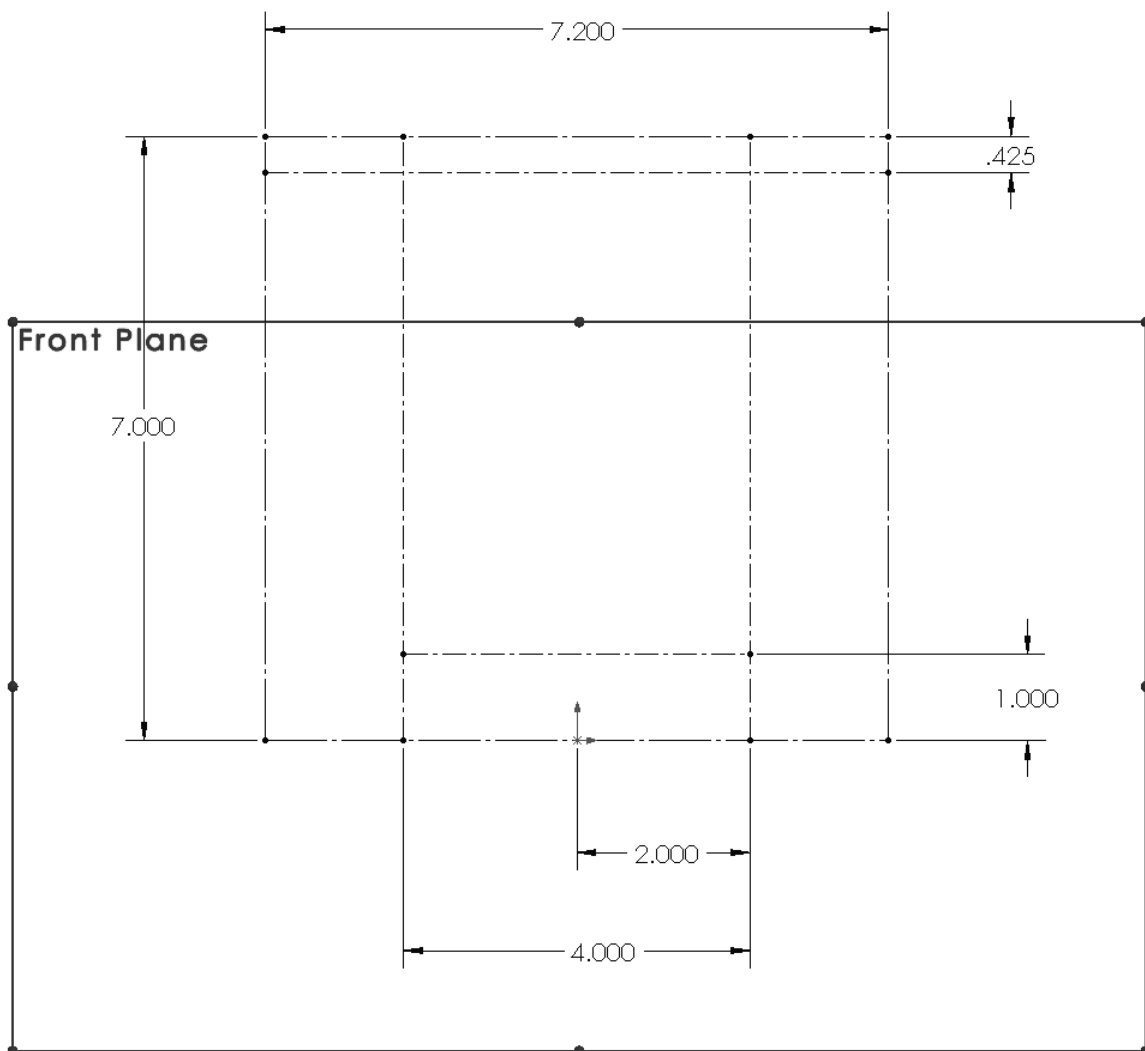

2. Inserting the picture:

- Click Tools / Sketch tools / Sketch Picture.

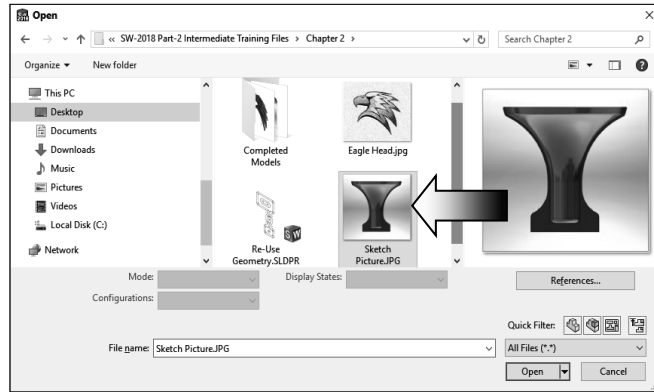
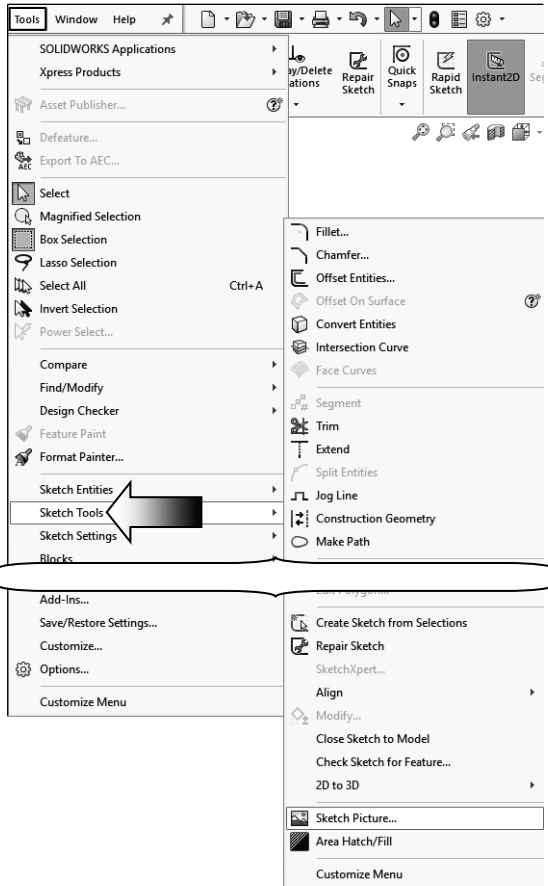

- Browse to the Training Files open the picture named Sketch Picture.jpg

Picture's properties

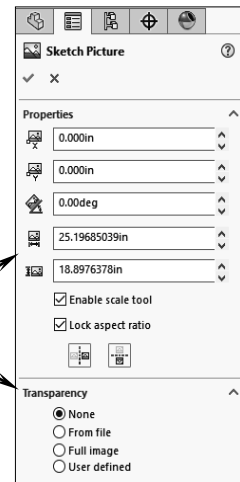

- The lower left corner of the picture is placed on the origin by default, and the picture's properties appear displaying the options for moving, rotating, and scaling the picture.

The lower left corner is placed on origin.

- We will need to scale the picture to match the construction box.

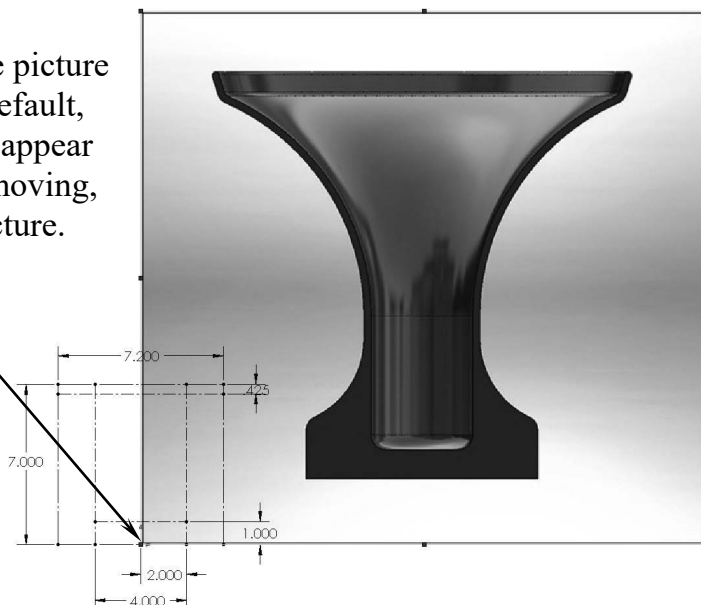

3. Scaling the picture:

- Using the Properties tree enter the following:

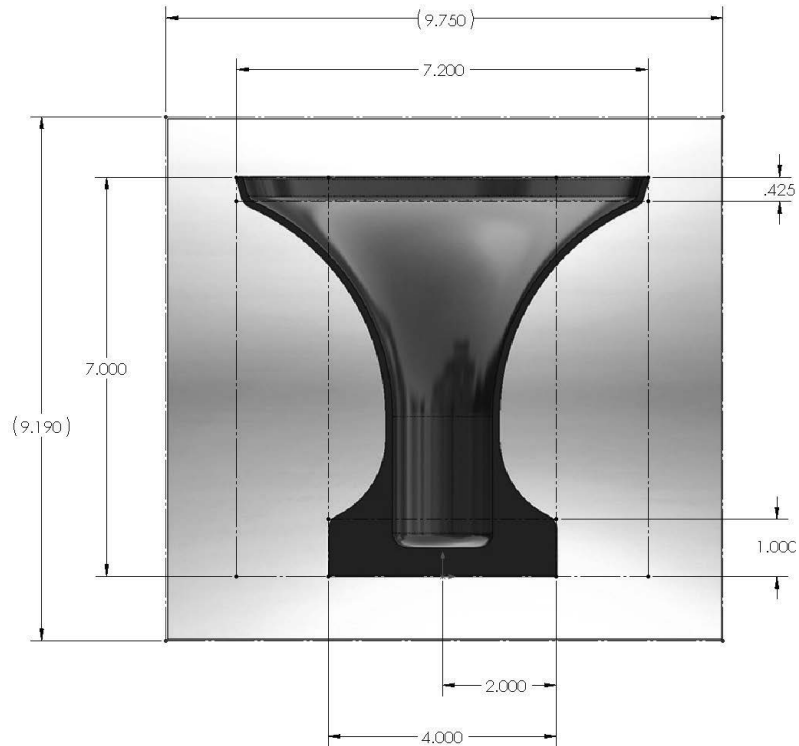
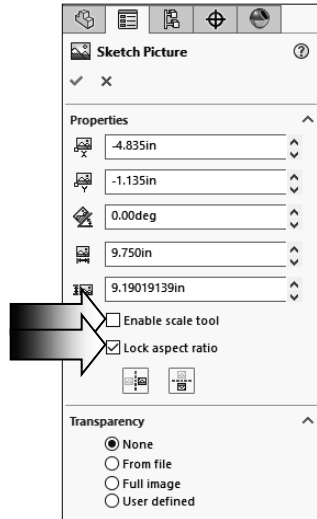

Location:

X = -4.835in.

Y = -1.135in.

Size:

Horizontal = 9.750in.

Vertical = 9.190in.

- Keep the option **Lock Aspect Ratio** checked and clear the **Enable Scale Tool** (arrows).
- Click **OK**.

4. Tracing the picture:

- The geometry in this picture can be traced with the line and arc commands.
- Sketch a line approx. as shown and connect it with a tangent arc.

Add a line and a tangent arc

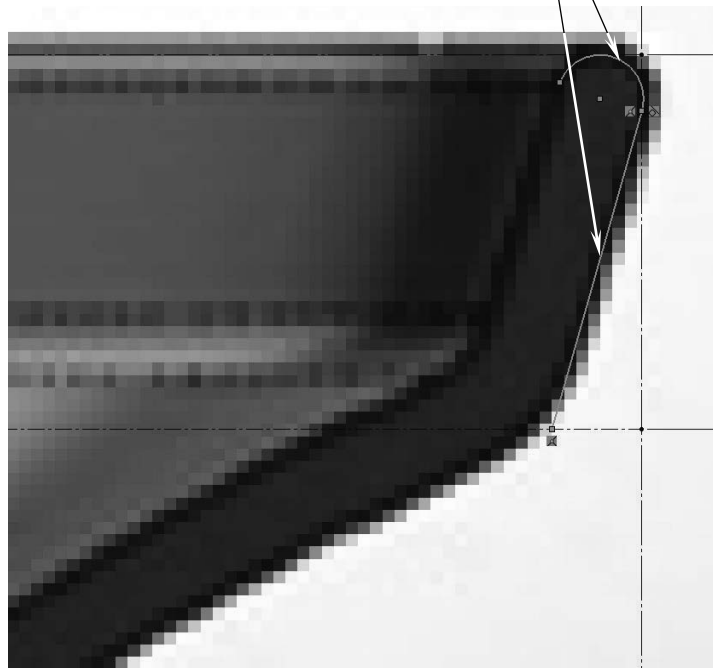

SOLIDWORKS 2018 | Intermediate Skills | Sketching

- Continue tracing the outline of the picture using the sketch tools as noted.
- Keep the corners sharp; they will be filleted at the end. Sketch only one half of the picture; the horizontal line at the bottom should stop right at the origin. The sketch will get revolved once completed.

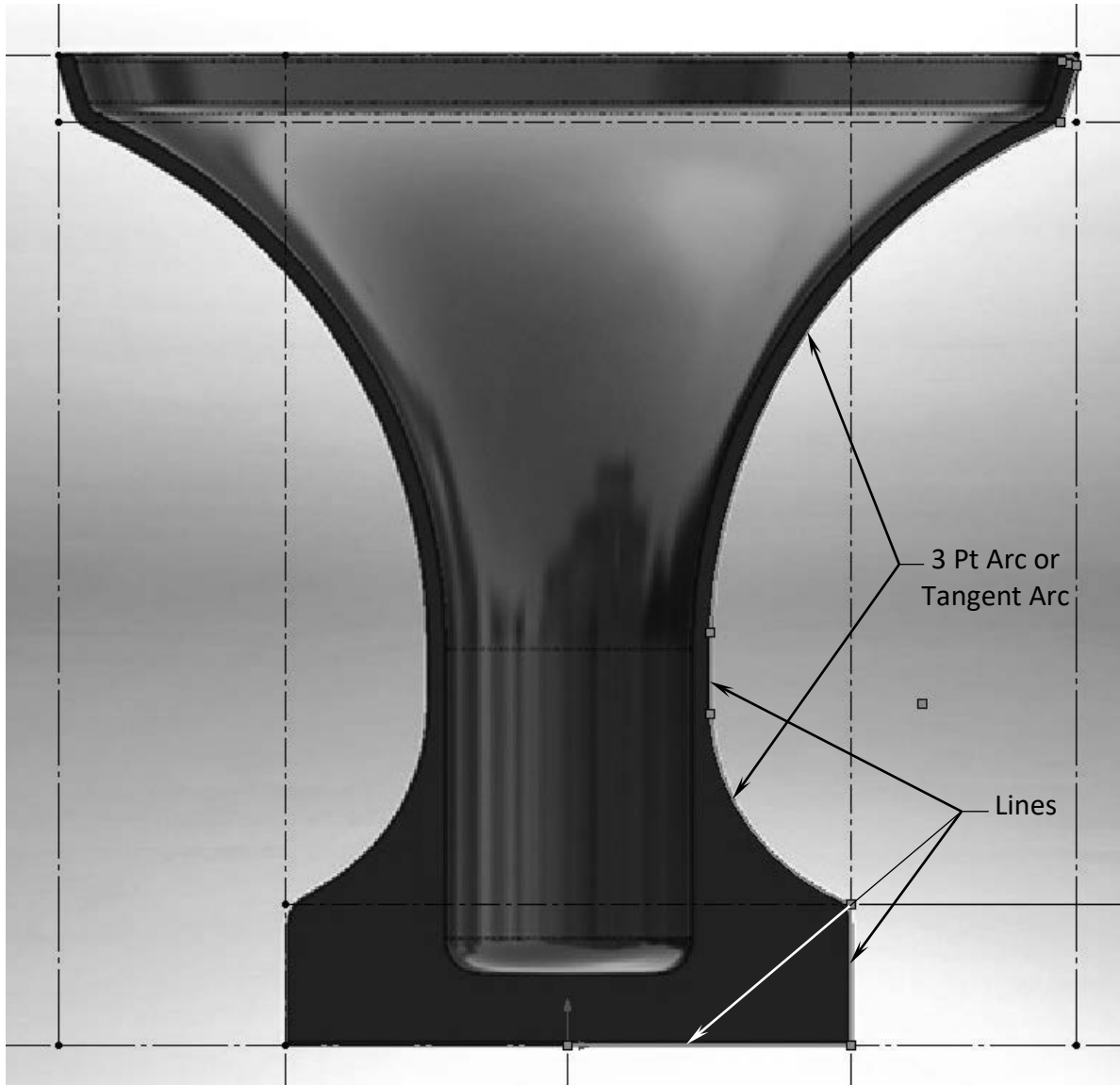

- If you accidentally got out of the sketch mode and the picture becomes inactive, simply double click the picture to reactivate it.
- You can adjust the sketch afterwards. When the sketch is completed, zoom in a little closer to the area that needs adjustment and drag the sketch entities back and forth.

5. Creating the offset entities:

- Click the **Offset Entities** command from the Sketch toolbar.
- Select the 3 entities as noted.
- Enter **.125in** for offset distance.
- Verify that the offset is showing on the left side, and click the reverse checkbox if needed.
- Click **OK** to close the offset command.

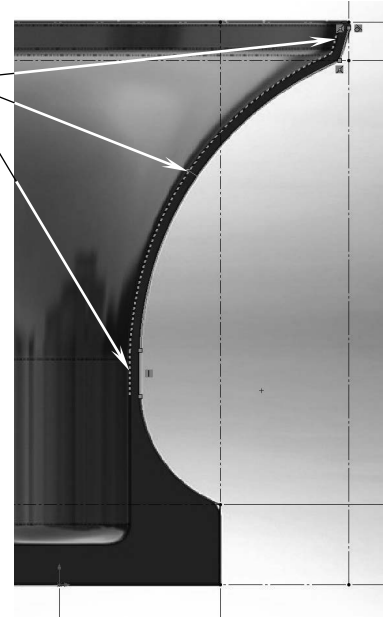
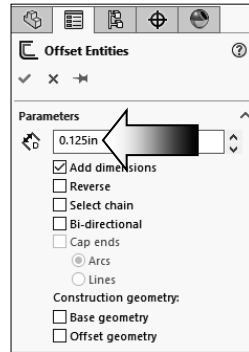

- Drag the endpoint of the vertical line downward as indicated.

Drag the endpoint until it lines up with the horizontal edge

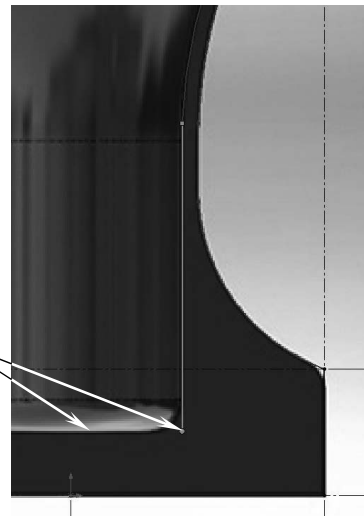

6. Closing off the sketch profile:

- Add **2 more lines** to close off the sketch profile.
- Snap the end of the last line to the origin. At this point, the sketch profile should be closed. To verify that all entities are in fact connecting with one another, right click one of the lines and pick **Select Chain**.

- If the entire sketch highlights, it indicates that all entities are connected properly.

Stop at origin

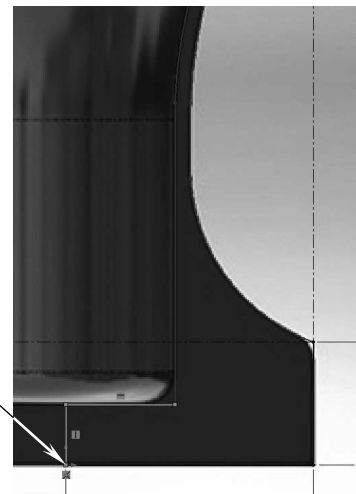

- Add a **Tangent** relation between the Arc and the line as indicated.

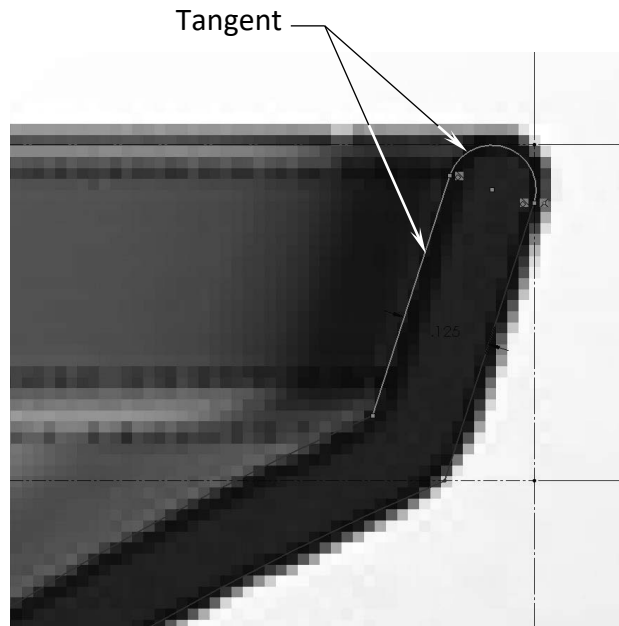

7. Adding the sketch fillets:

- It would be easier to create the fillets within the same sketch. That way we can see if they are going to look right while the sketch still overlays with the picture.

- Click the **Sketch Fillet** command from the Sketch toolbar.

- Enter **.250"** for radius.

- Select the 3 vertices as noted, and keep the **Constraint Corners** option checked.

- The preview fillets should look similar to your image.

- Click **OK**.

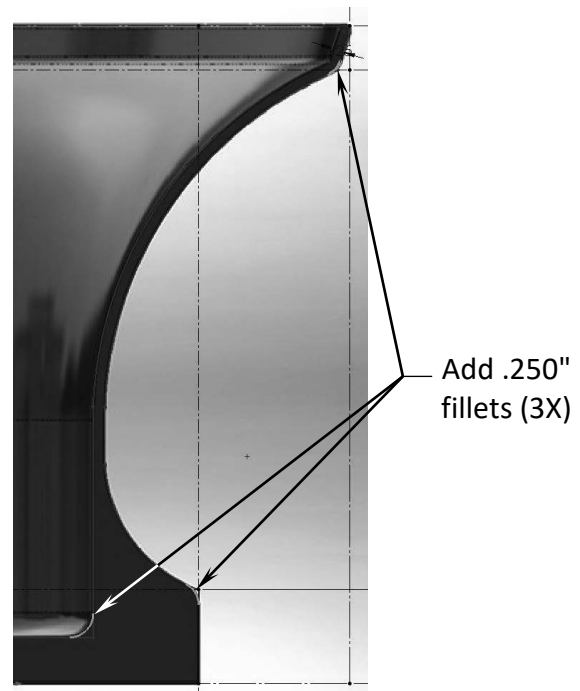
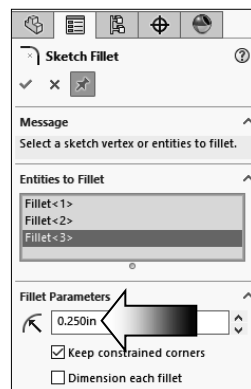

SOLIDWORKS 2018 | Intermediate Skills | Sketching

- Change the fillet size to **.125"**.

- Select the vertex as noted to apply the new fillet.

- Keep the option **Constraint Corners** checked.

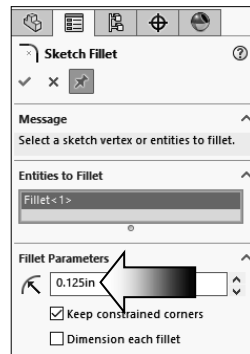

Add .125"
fillet (1X)

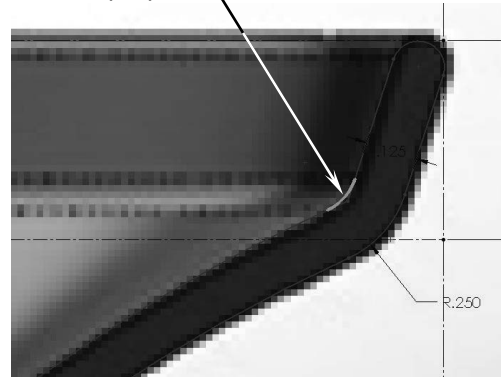

- Click **OK** twice to exit the fillet command.

- Add a vertical centerline as shown. It will be used to revolve the sketch profile.

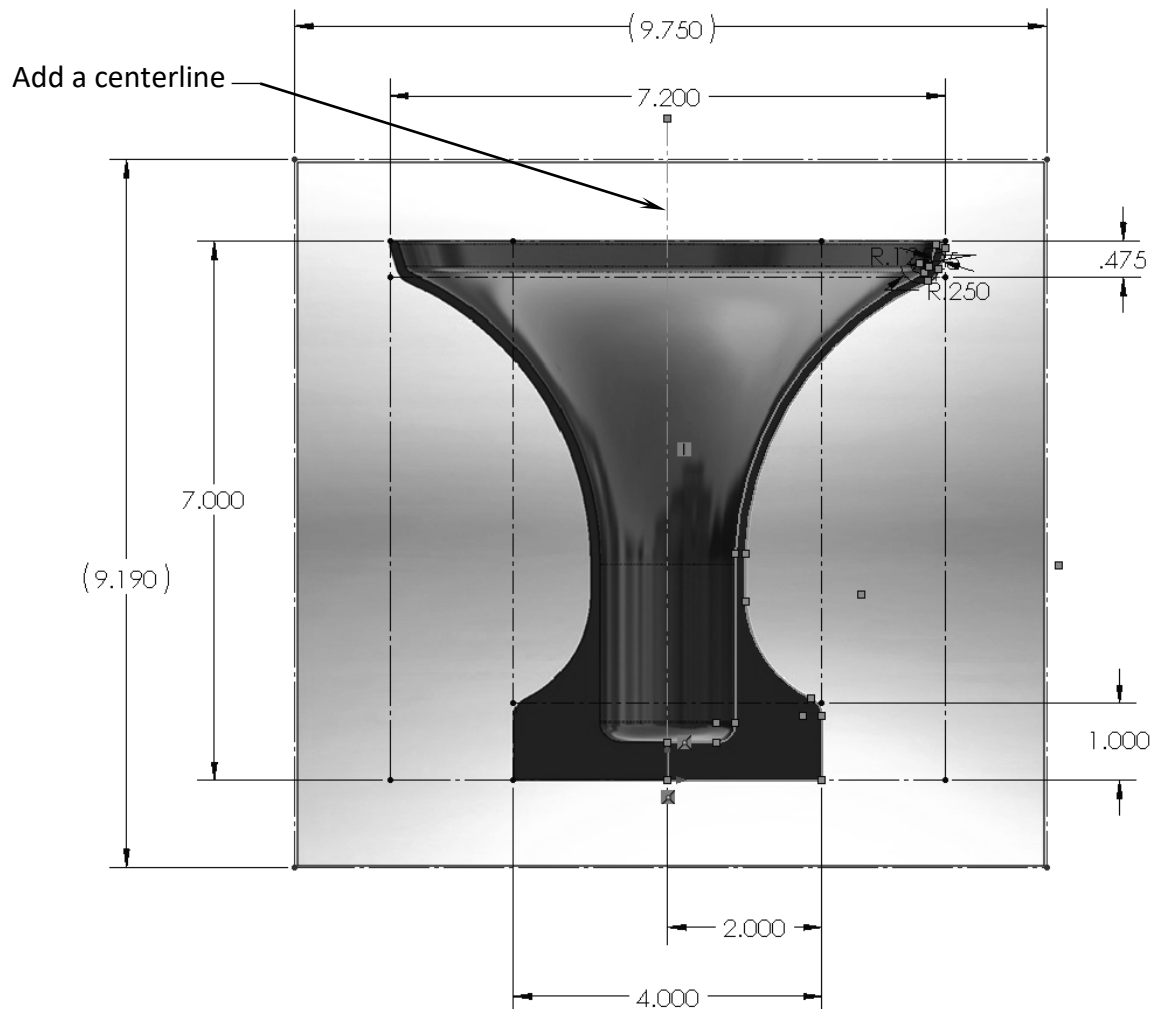

8. Revolving the profile:

- Select the vertical centerline and click the **Revolve Boss/Base** from the Features toolbar.

- Use the default **Blind** type and the **360°** angle.

- Click **OK**.

- Expand the Revolved1 feature and suppress the Sketch Picture.

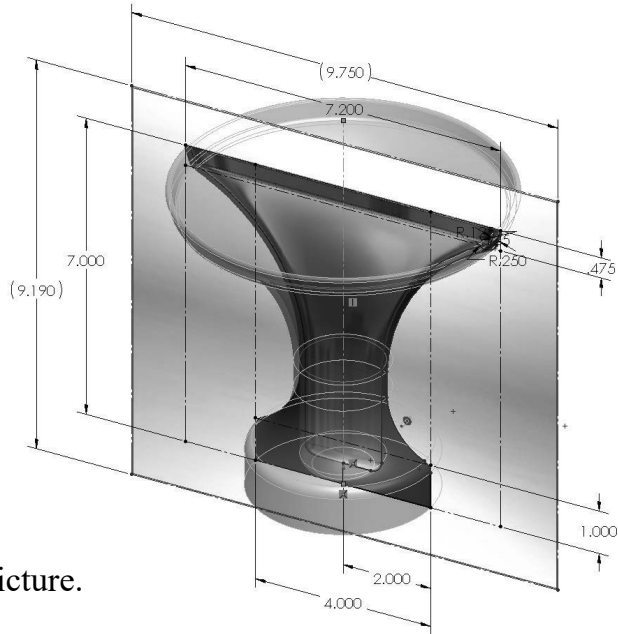
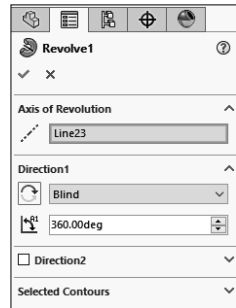

- Use the Front plane and create a section view to verify the thickness of the revolved part. Exit the section view when you are done viewing.

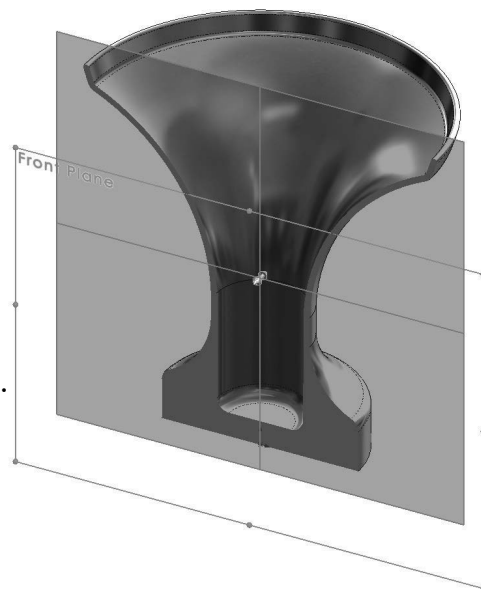

9. Measuring the Mass:

- Switch to the **Evaluation** tool tab.
- Change the material to **Aluminum Bronze**.
- Click the **Mass Properties** command.
- Using 3 decimals, enter the mass here:

_____ (6.35lbs +/- .15 lbs.)

10. Saving your work:

- Save your work as **Sketch Picture Completed**.
- **Close** the part document.

NOTE: Refer to the completed part saved in the Training Files folder for reference, or to compare your results against it.



Exercise: Working with Sketch Pictures & using the Spline tool

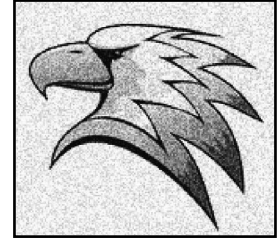

- A digital image can be used as a reference to model a part. Each image can be placed on its own plane, so several images can be inserted to help define the shape of the model from different orientations.
- Formats such as jpg, tif, bmp, gif, png, etc., are supported in SOLIDWORKS. They can be inserted and converted into a sketch, so that a feature can be made from it.



- When scanning or saving the digital images, it is best to use fine resolution and high contrast pictures. Sketching over the sharp edges would be much easier than the blurry edges.
- Splines are often used to do the tracing of the images due to their flexibility in manipulating the shapes, and splines offer a set of control tools to assist you with creating and maintaining the smoothness of the curves.

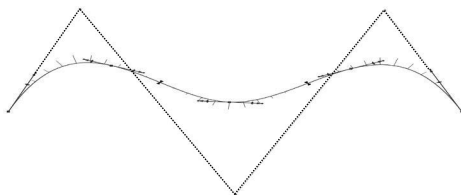

- - The digital or scanned image can be scaled to size and repositioned with reference to the origin so that dimensions can be added for accuracy.

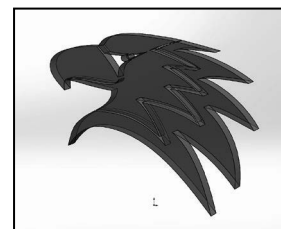
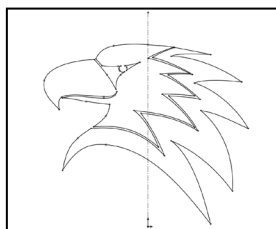

1. Inserting the scanned image:

- The scanned image should be inserted onto an active sketch.
- In a new part file, select the Front plane and open a new sketch.
- From the **Tools** menu, click **Sketch Tools / Sketch Picture**. 

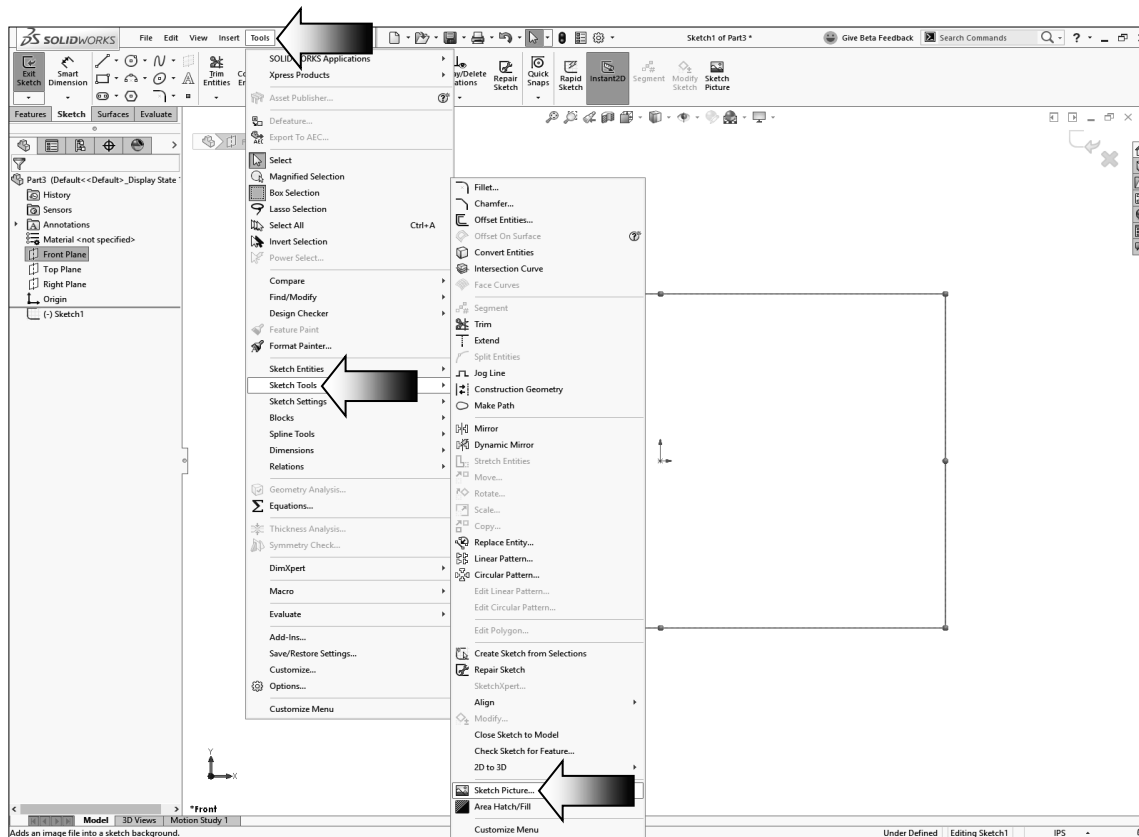

- Browse to the Training Files folder and select the file named **Eagle Head.jpg** and open it.

- The lower left corner of the image is placed on the origin.

- The image size and locations appear on the properties tree; we will modify those dimensions in the next step.

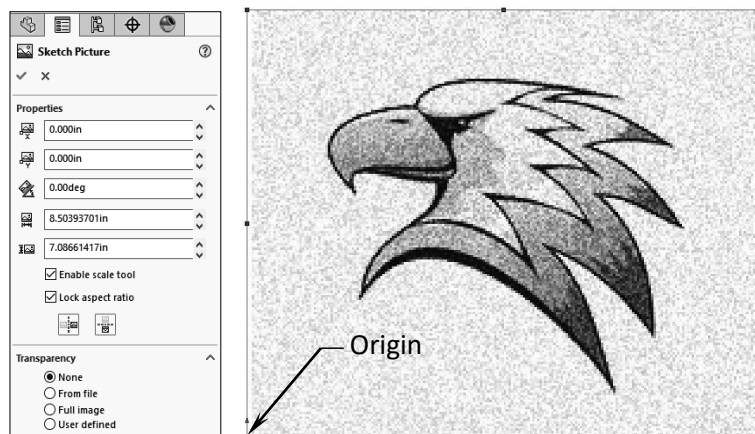

2. Positioning and sizing the scanned image:

- Sketch a **vertical centerline** to help center the image.
- Double click the image to activate it.
- Enter the following dimensions to re-position and re-size the image:

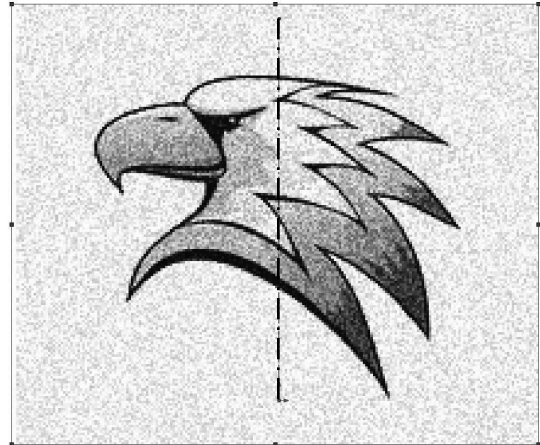
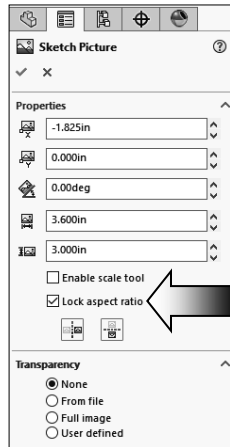

- * X = **-1.825in.**
- * Y = **-0.00in.**
- * Angle = **0deg.**
- * Width = **3.600in.**
- * Height = **3.000in.**

- Be sure to enable the **Lock Aspect Ratio** checkbox (arrow).
- Click **OK**.

Splines:

- A spline is a sketch entity that gets its shape from a set of spline points. This tool is great for modeling free-form shapes that require a little more “flexibilities” than other curve tools.
- During the creation of a spline, each click creates a spline point and these points can be added or deleted when needed.

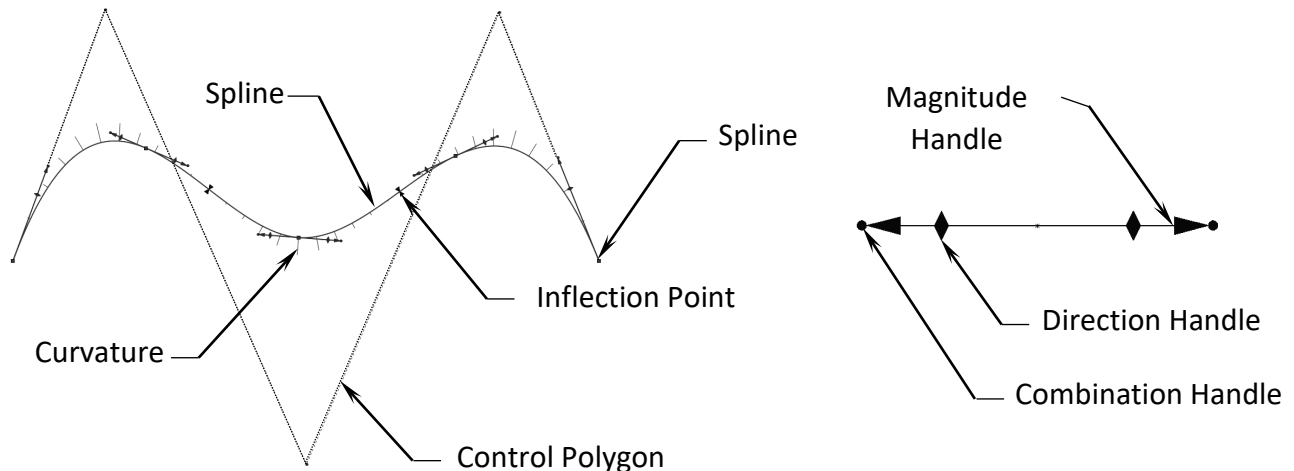

SOLIDWORKS 2018 | Intermediate Skills | Sketching

- Try to use as few spline points as possible in the general, long curving areas.
- Only use more spline points on tighter, smaller radiuses.
- Use the spline handles to drag freely, or hold the ALT key to drag symmetrically. The spline handles are used to change the direction and magnitude of the tangency at a spline point.
- Use the Control Polygons in place of the spline handles. Drag its control points to manipulate the spline.
- The Curvature Combs display the curvature of the spline in a form of a series of lines called a comb. The length of the lines represents the curvature. The longer the line, the larger the curvature, and the smaller the radius.
- Inflection Points or Markers are used to show the inflection changes in a spline, whether it is convex or concave.

3. Tracing the image with the spline tool:

- The sketch should still be active at this time; select the **Spline** command from the Sketch toolbar.

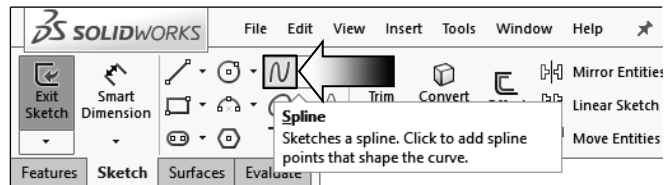

- Keep in mind that the simpler the spline, the easier it is to manipulate it. So we are going to create one spline with two or three spline points each time, and then adjust it to match the outline of the image as close as possible. (Zoom in a little closer.)

- Start at “**point 1**,” and “**point 2**,” then “**point 3**” as indicated.

- Push the **Escape** key when done.

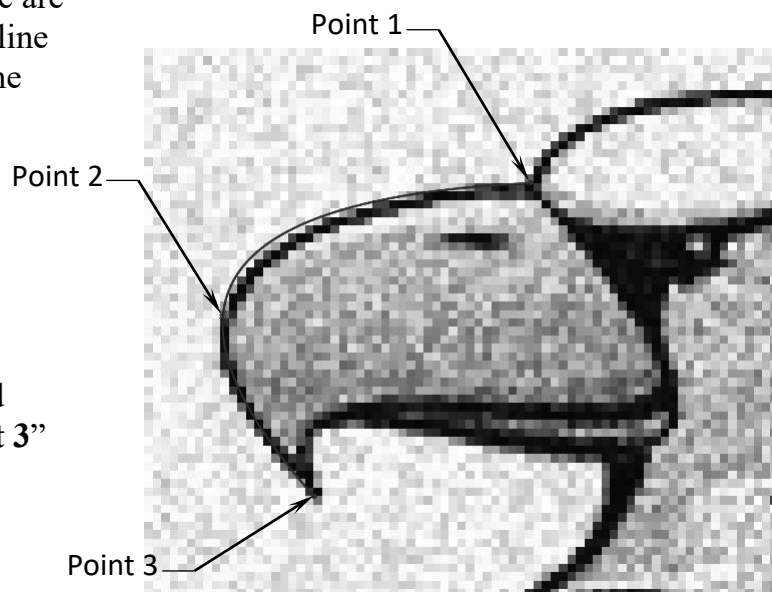

SOLIDWORKS 2018 | Intermediate Skills | Sketching

- Zoom in even closer so that you can adjust the spline a little easier.

Drag the Spline-Handles to adjust the curvature

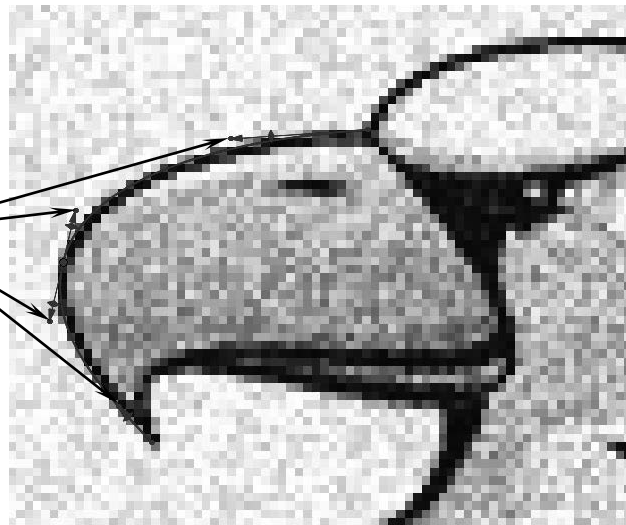

- Click on the spline to see its handle points and start pulling on the points at the tips of each handle.

- It may take some getting used to, so work on a small area each time. Create only one spline each time, and each spline should have two or three points only.

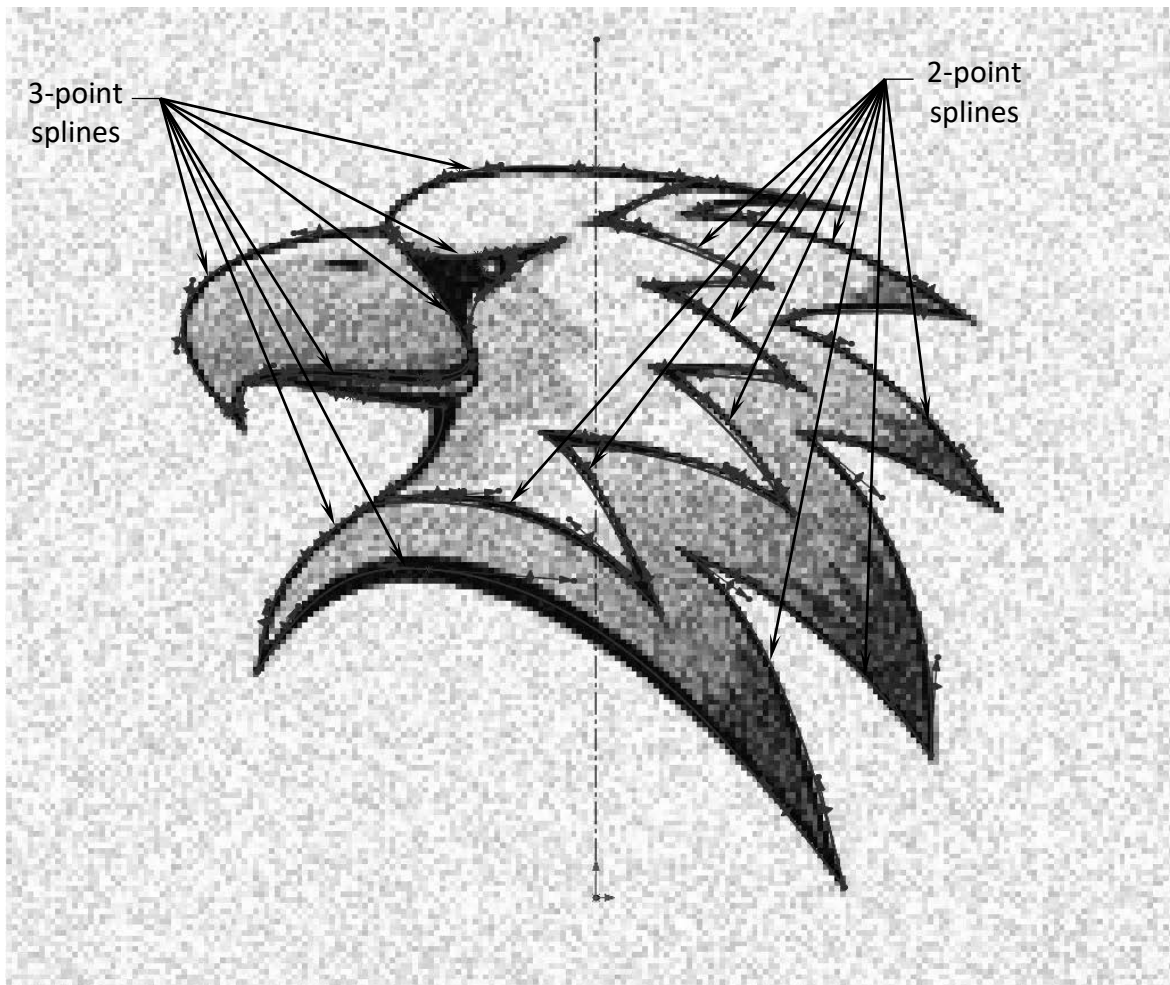

- There should be a small gap around the sketch (as noted) so that a single sketch can be extruded into a feature.

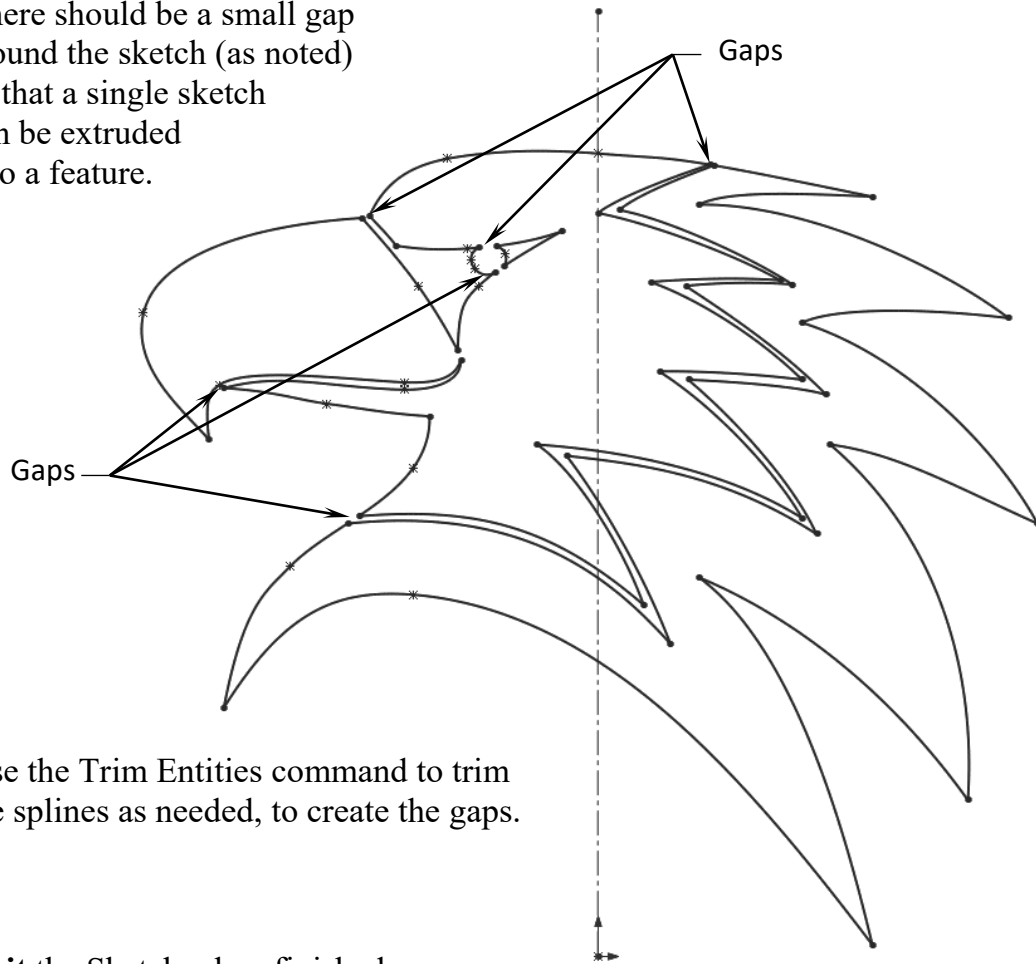

- Use the Trim Entities command to trim the splines as needed, to create the gaps.

- **Exit** the Sketch when finished.

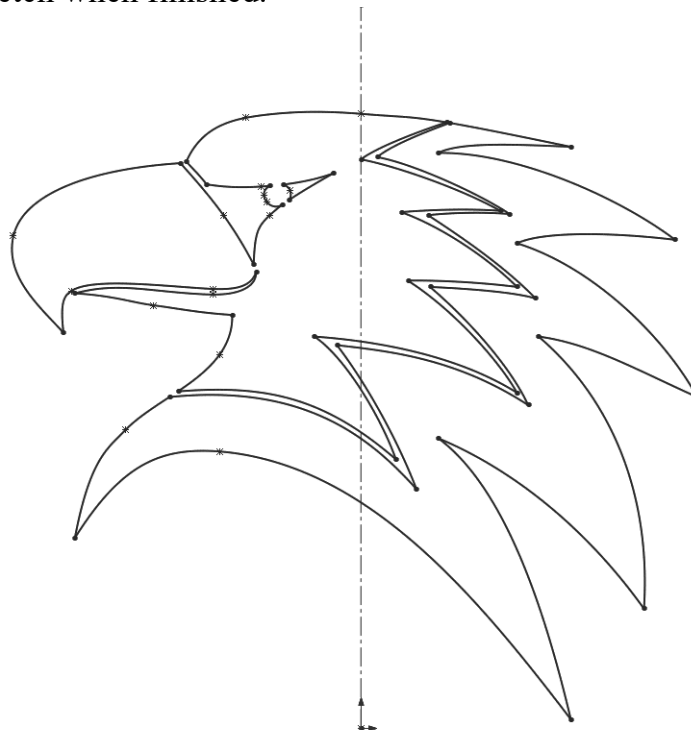

4. Extruding the traced sketch:

- Click **Extruded Boss-Base**.
- Use the default **Blind** type and enter **.125"** for thickness.
- Click **OK**.

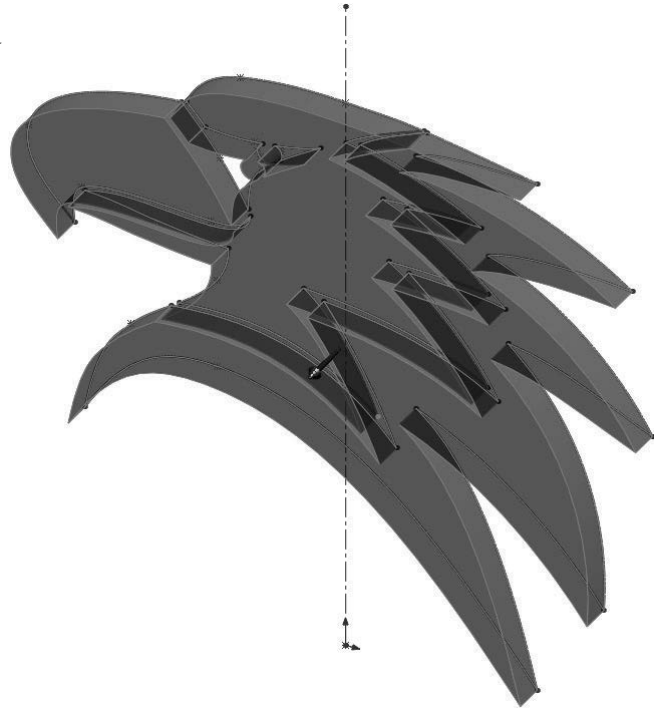
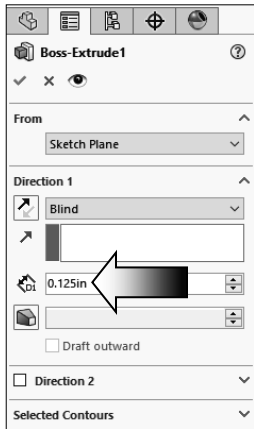

5. Optional:

- Use **Photoview 360** and render the model with the following settings:
- Appearances: **Glass / Clear Thick Gloss / Clear Thick Glass**.
- Scene: **Studio Scenes / Reflective Floor Black**.
- Lighting: **Green**
Brown
Blue
- Output Image Quality:
1280 X 1024



6. Saving your work:

- Save your work as **Eagle Head_Sketch Picture**.

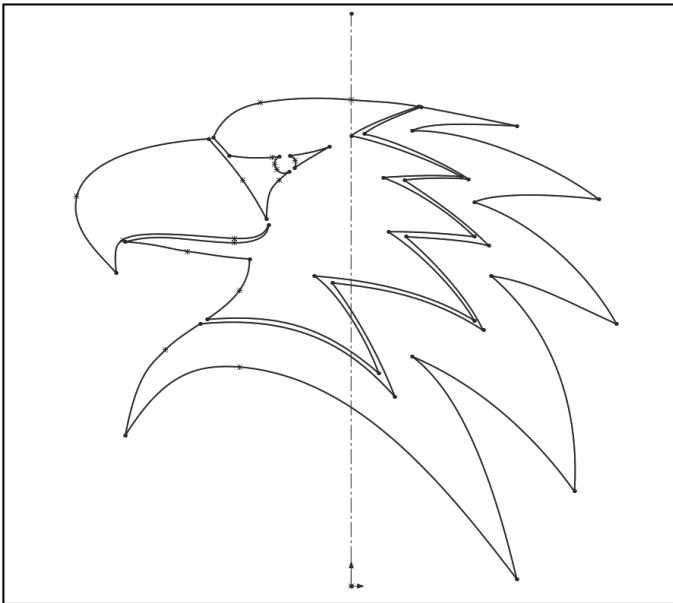
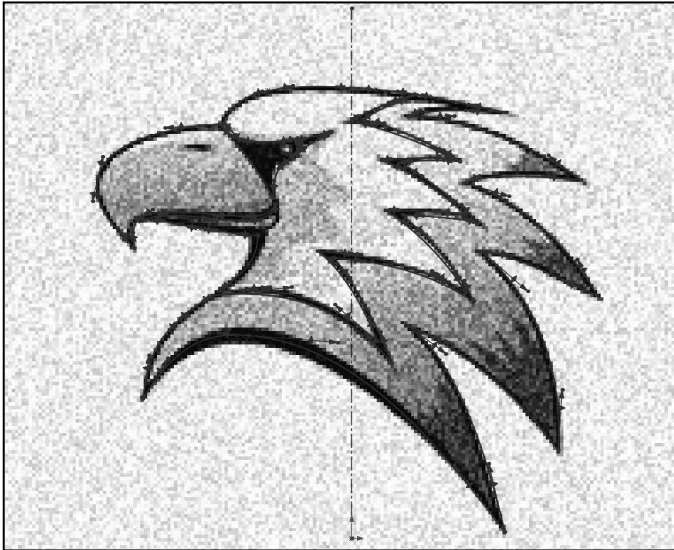

Re-use Geometry

The Contour Select Tool  allows you to select sketch contours and model edges, and apply features to them. The same sketch can be re-used over and over again.

Contour selection is also restricted as follows:

- * When reusing a sketch, you can select only on the original face. If, for example, part of the face has been extruded, the tool does not recognize the new face.

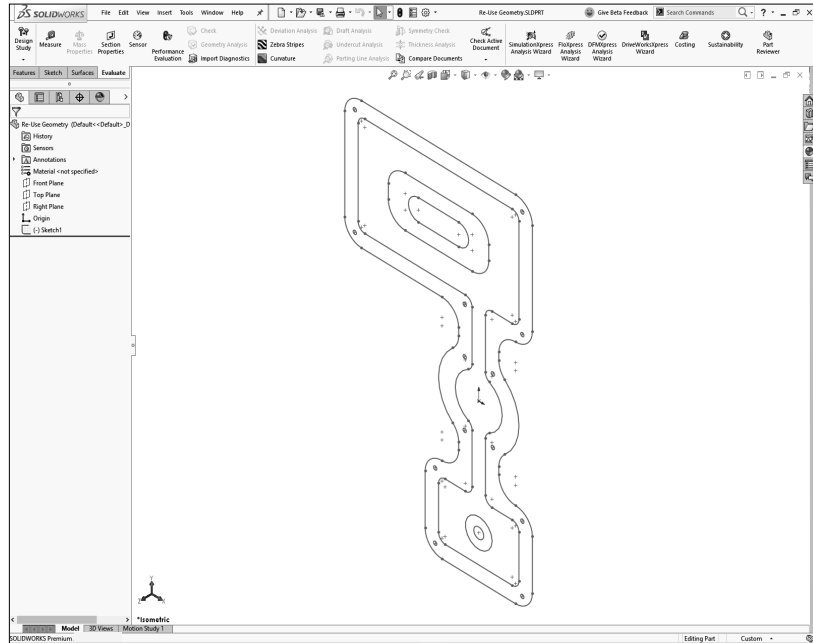

- * You can select contours only on the face with the sketch. If, for example, the face with the sketch is cut by a solid object (as shown below), the tool can select the part of the face still visible but does not recognize the solid object.

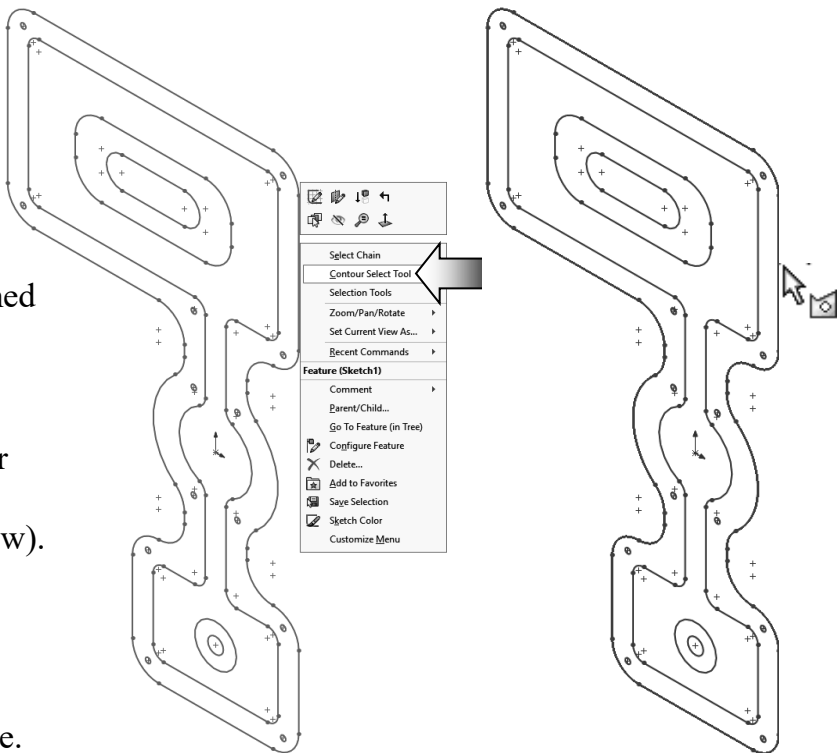

1. Open a part document named **Re-Use Geometry.sldprt**

2. Right click one of the outer sketch entities and select **Contour Select Tool** (arrow).

The entire outer contour is selected; it will be extruded first to create the parent feature.

3. Switch to the Features tool bar and click **Extruded Boss Base**.

4. Use the default **Blind** type and enable the **Reverse** direction.

5. Enter a thickness of **1.500in**.

6. Click **OK**.

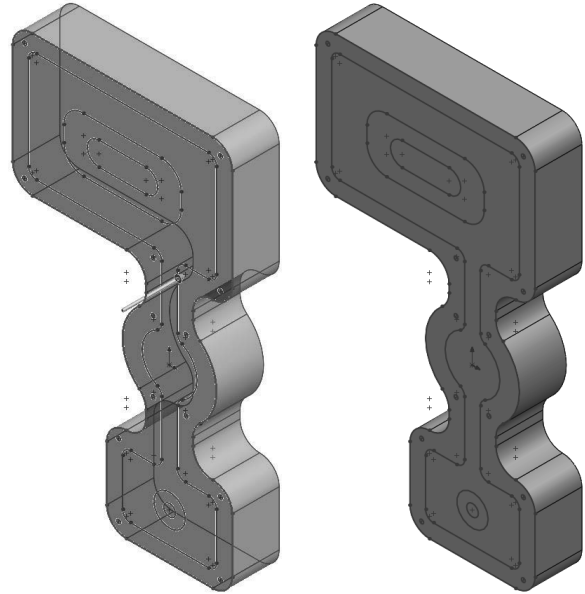
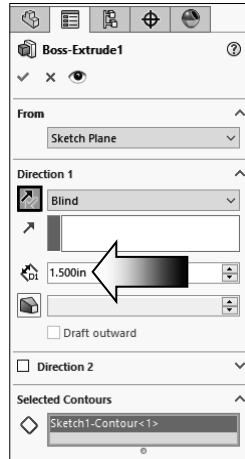

7. Right click one of the sketch entities and select **Contour Select Tool** again (arrow).

8. Hold the **Control** key and select the **3 contours** as indicated below.

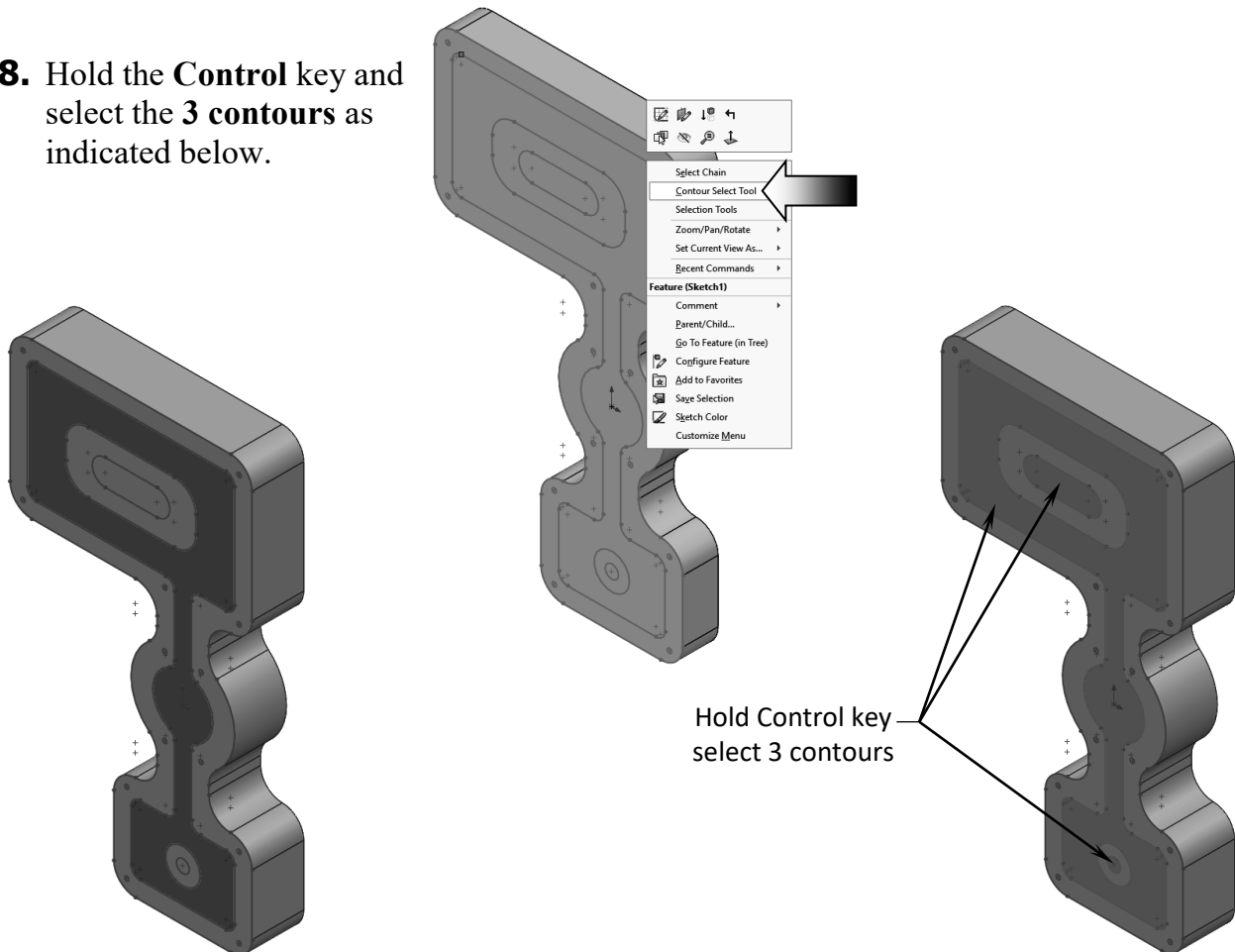

9. Switch to the Features tool bar and click **Extruded Cut**.

10. Use the default **Blind** type.

11. Enter a depth of **1.000in**.

12. Click **OK**.

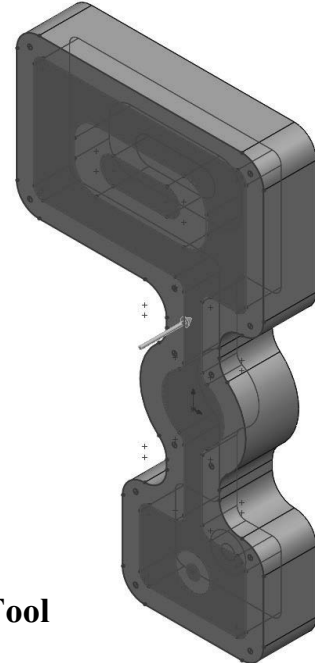
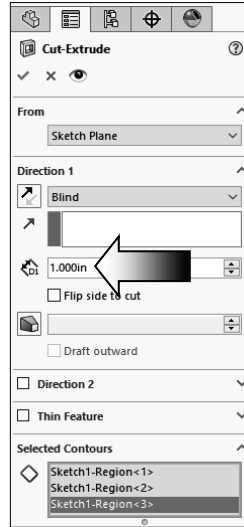

13. Right click one of the circles and select **Contour Select Tool** once again (arrow).

14. Hold the **Control** key and select all 13 circles as indicated below.

15. Click **Extruded Cut**.
For Direction 1, select **Through All**.

16. Click **OK**.

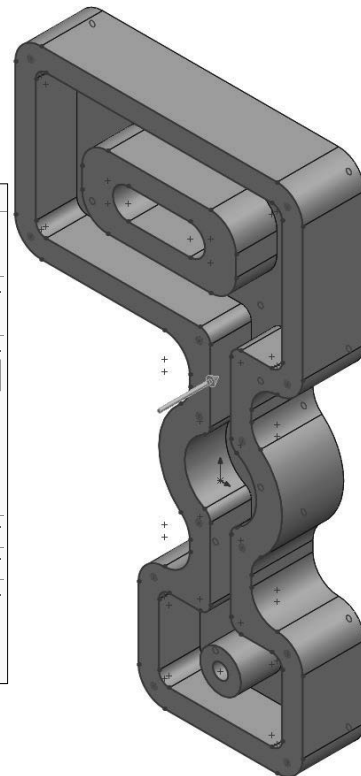
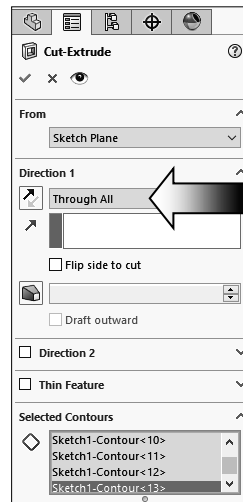
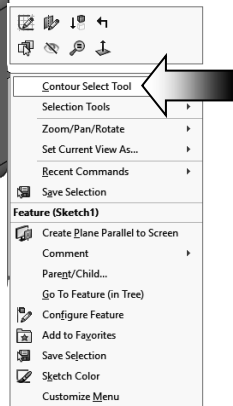
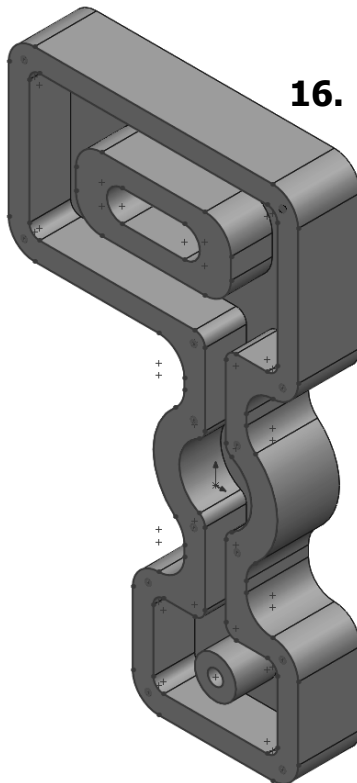

SOLIDWORKS 2018 | Intermediate Skills | Sketching

Expand the features to see the sketches under them.

The symbol  means the sketch has been used several times to create multiple features. It is called **Share Sketch**.

Click one of the sketch entities and select **HIDE**.

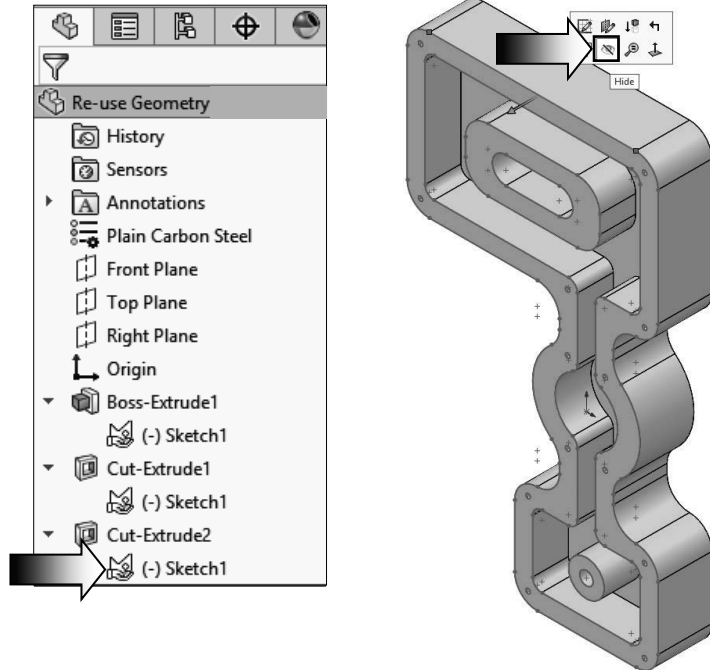

17. Save and close the part document.

