

Certified SOLIDWORKS® Professional Advanced Preparation Material

Sheet Metal, Weldments, Surfacing,
Mold Tools and Drawing Tools

SOLIDWORKS® 2019

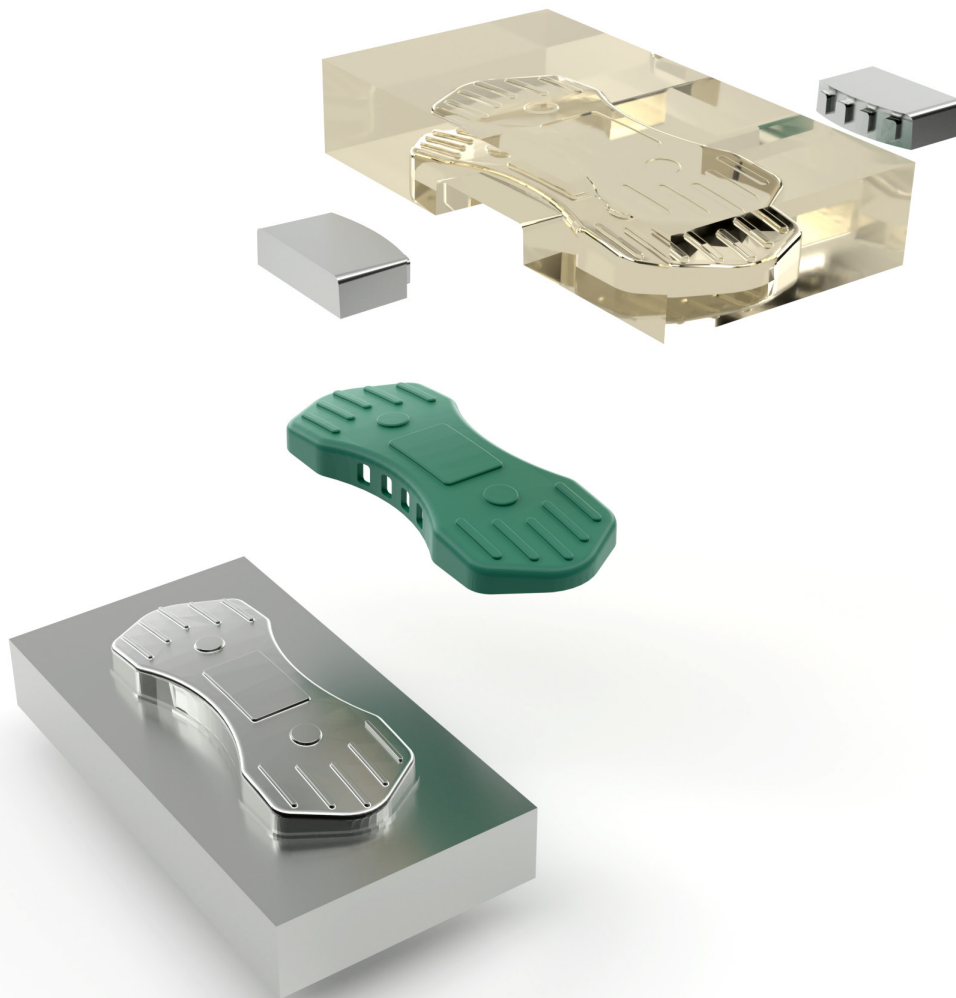

Paul Tran CSWE, CSWI

Visit the following websites to learn more about this book:



[amazon.com](https://www.amazon.com)

[Google books](https://books.google.com)

[BARNES & NOBLE](https://www.barnesandnoble.com)

CHAPTER 1

Drawing Tools



CSWPA - Drawing Tools

Certified SOLIDWORKS Professional Advanced Drawing Tools

The completion of the Certified SOLIDWORKS Professional Advanced Drawing Tools (CSWPA-DT) exam proves that you have successfully demonstrated your ability to use the tools found in the SOLIDWORKS Drawing environment.

Employers can be confident that you understand the tools and functionality found in the SOLIDWORKS Drawing environment.

Note: You must use at least SOLIDWORKS 2010 for this exam. Any use of a previous version will result in the inability to open some of the testing files.

Exam Length: 100 minutes

Minimum Passing grade: 75%

Re-test Policy: There is a minimum 30 day waiting period between every attempt of the CSWPA-DT exam. Also, a CSWPA-DT exam credit must be purchased for each exam attempt.

All candidates receive electronic certificates and a personal listing on the CSWP directory when they pass.

Exam features hands-on challenges in many of these areas of SOLIDWORKS drawing functionality such as:

Basic View Creation, Section Views, Auxiliary Views, Alternate position Views, Broken Out Sections, Lock View/Sheet Focus, Transferring Sketch Entities to/from Views, Bill of materials, and Custom Properties.

CSWPA - Drawing Tools

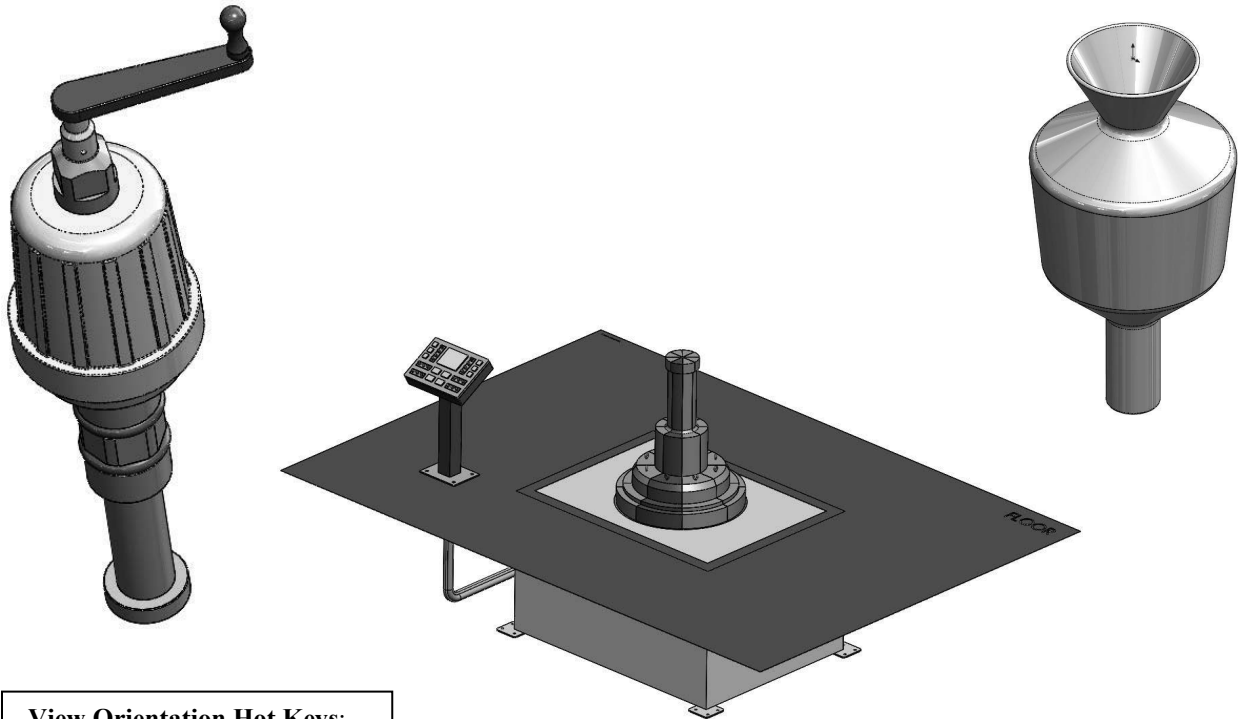

View Orientation Hot Keys:

- Ctrl + 1 = Front View
- Ctrl + 2 = Back View
- Ctrl + 3 = Left View
- Ctrl + 4 = Right View
- Ctrl + 5 = Top View
- Ctrl + 6 = Bottom View
- Ctrl + 7 = Isometric View
- Ctrl + 8 = Normal To Selection

Dimensioning Standards: **ANSI**

Units: **INCHES** – 3 Decimals

Tools Needed:



Part Template



Assembly Template



Drawing Template



View Palette



Section View



Named View



Measure



Auto Balloon



Bill of Materials

CHALLENGE 1

1. Opening a part document:

- Select **File / Open**.
- Browse to the Training Folder and open the part document named **Tank.sldprt**.

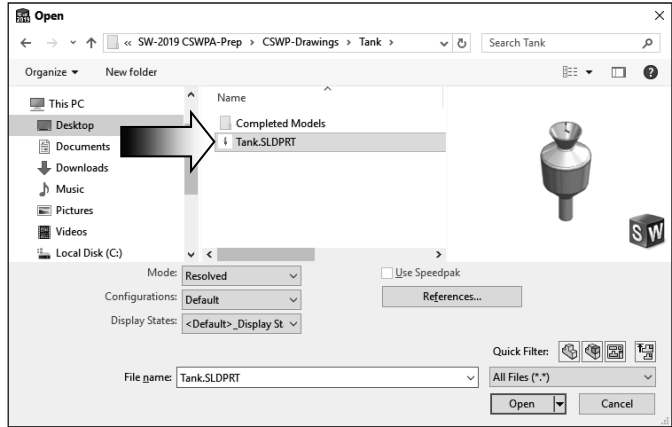

2. Transferring to a drawing:

- Select **File / Make Drawing From Part** (arrow).

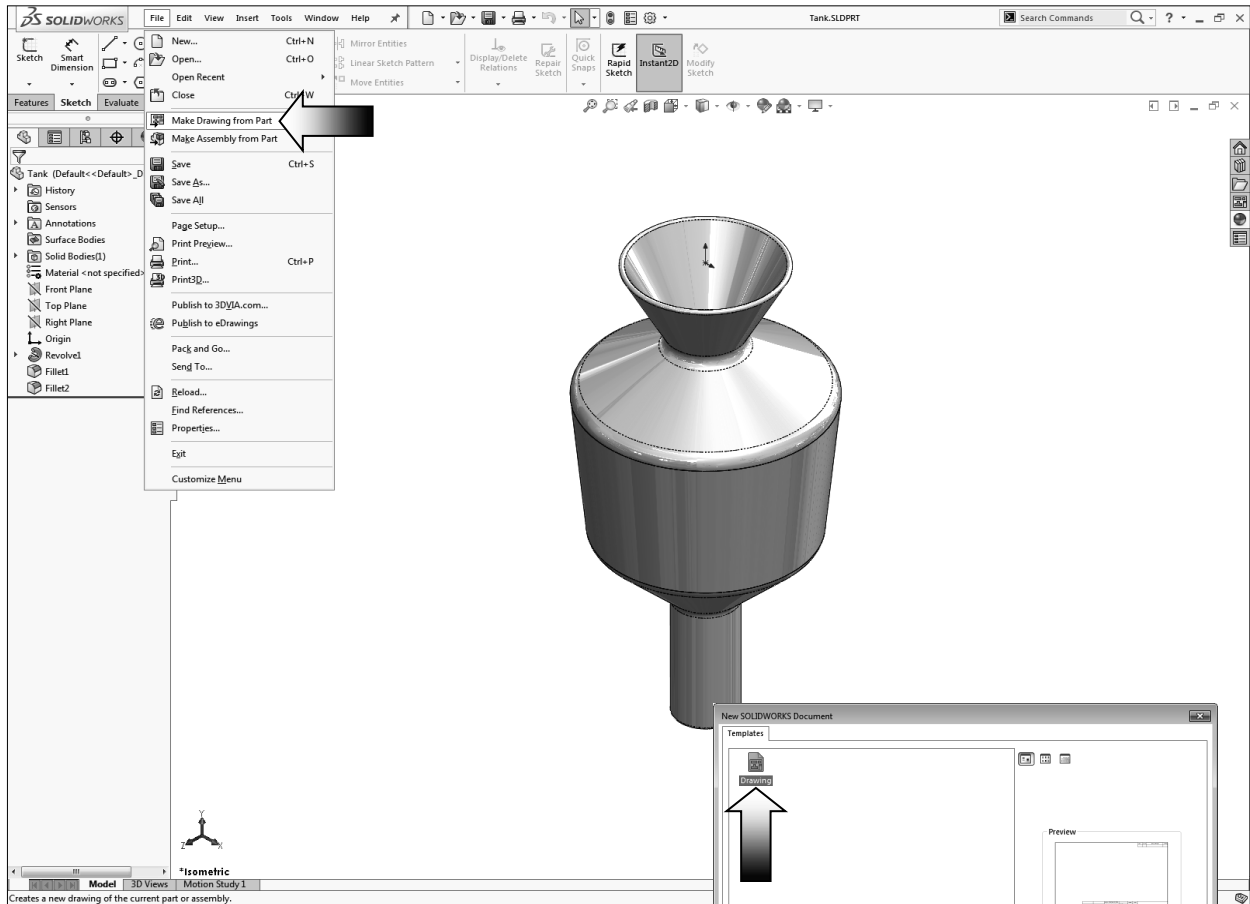

- Select the default **Drawing** template.
- Click **OK**.

3. Changing the paper size:

- Right click inside the drawing and select **Properties**.

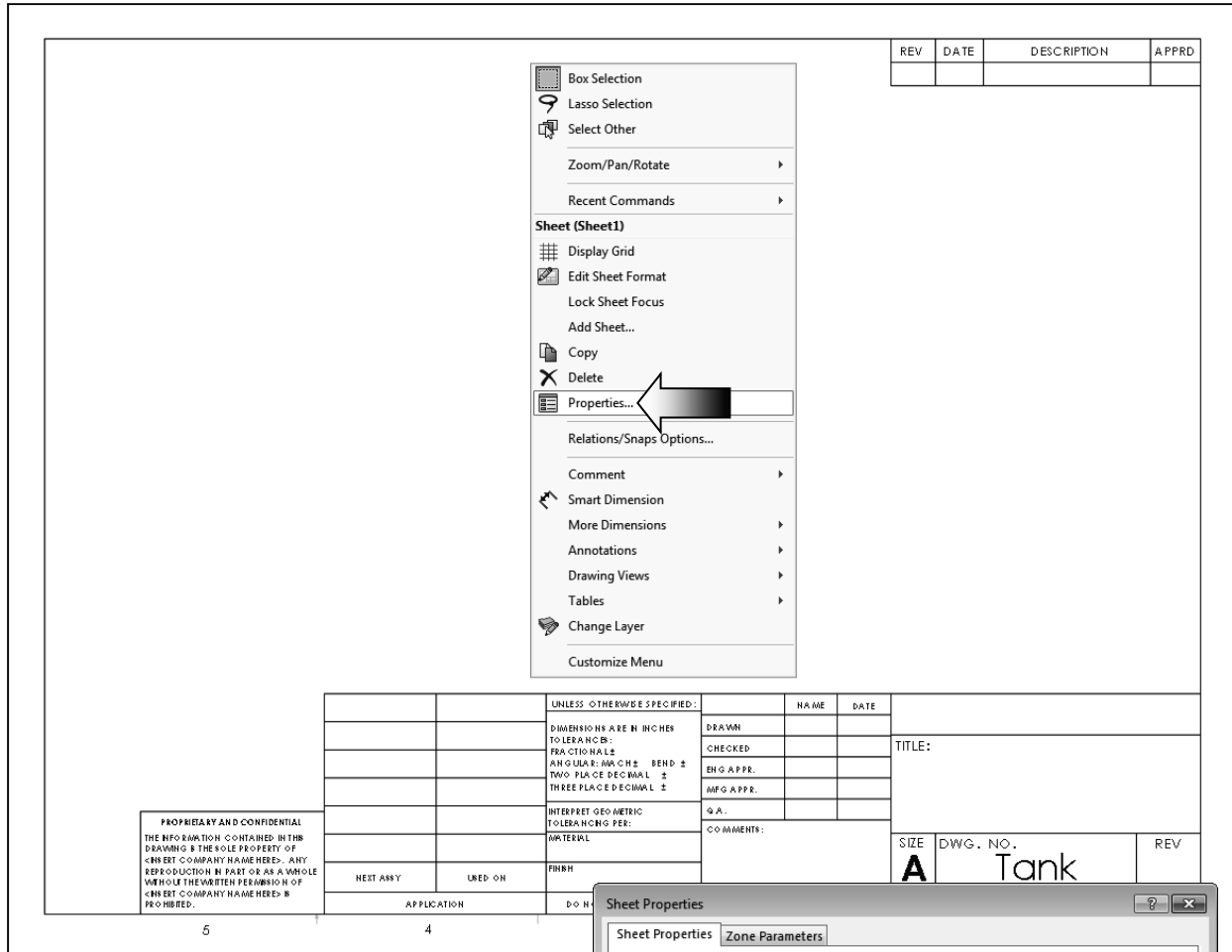

- Set the following:

- * **Scale: 1:1**
- * **Third Angle Projection.**
- * **C (ANSI) Landscape.**
- * **Display Sheet Format enabled.**

- Click **OK**.

4. Adding the drawing views:

- Expand the **View Palette** (arrow) and drag the **Front-View** approximately as shown.

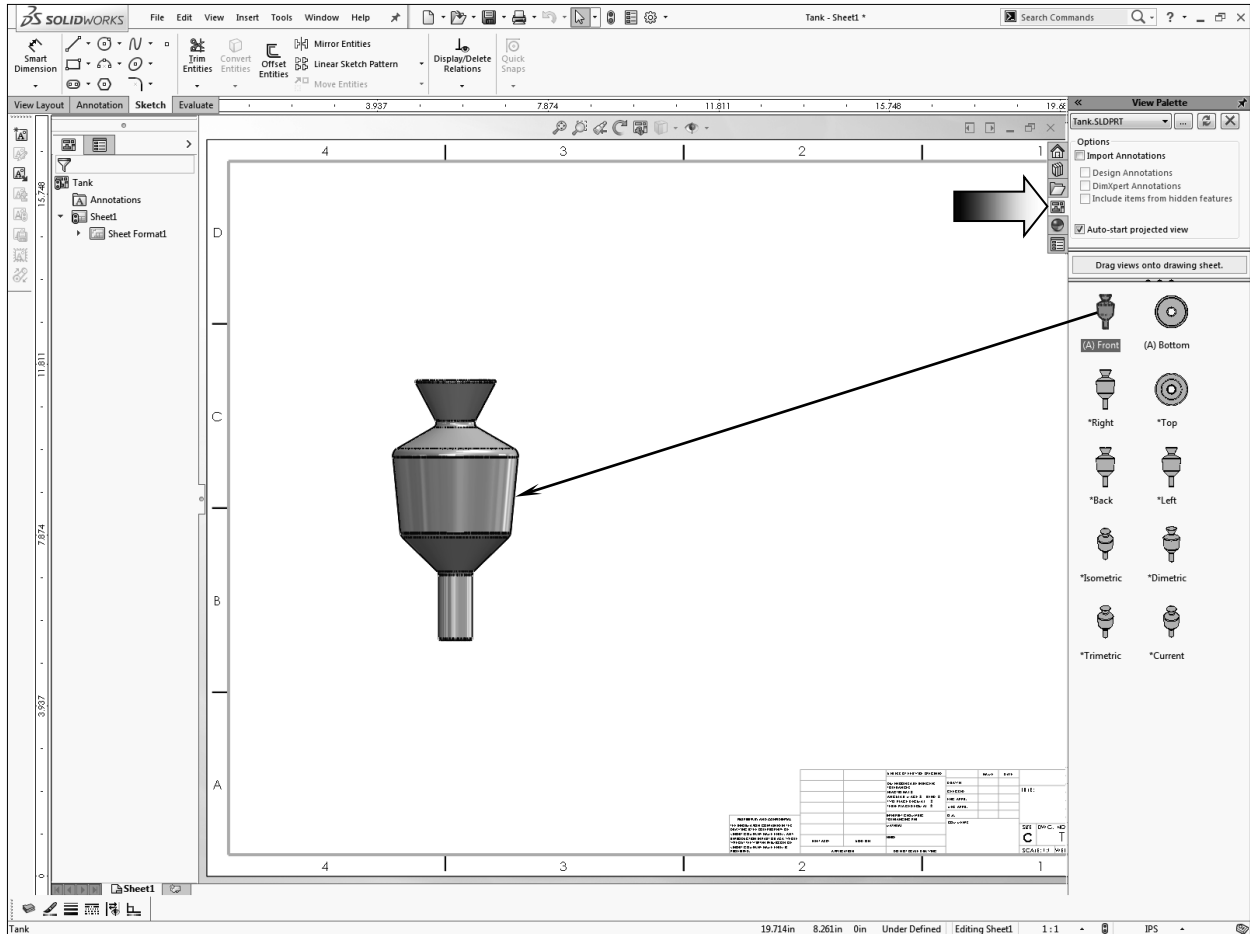

- Project from the Front view or drag and drop the Isometric view from the View Palette.
- Place the Isometric view on the right side of the Front view.
- For clarity, change the tangent edges to With-Font (right click the view's border and select Tangent Edges With Font).

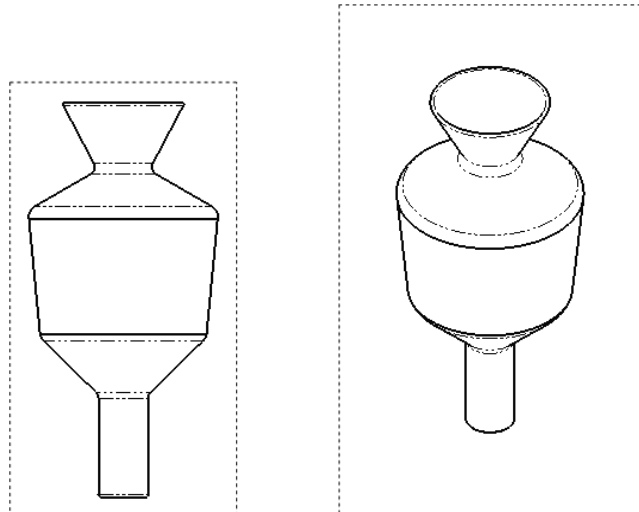

5. Creating a section view:

- Change to the **View Layout** tool tab.
- Click the **Section View** command.
- For Cutting Line, select the **Vertical** option (arrow).
- Place the Cutting Line in the middle of the Front view and click the green check mark (arrow) to accept the line placement.

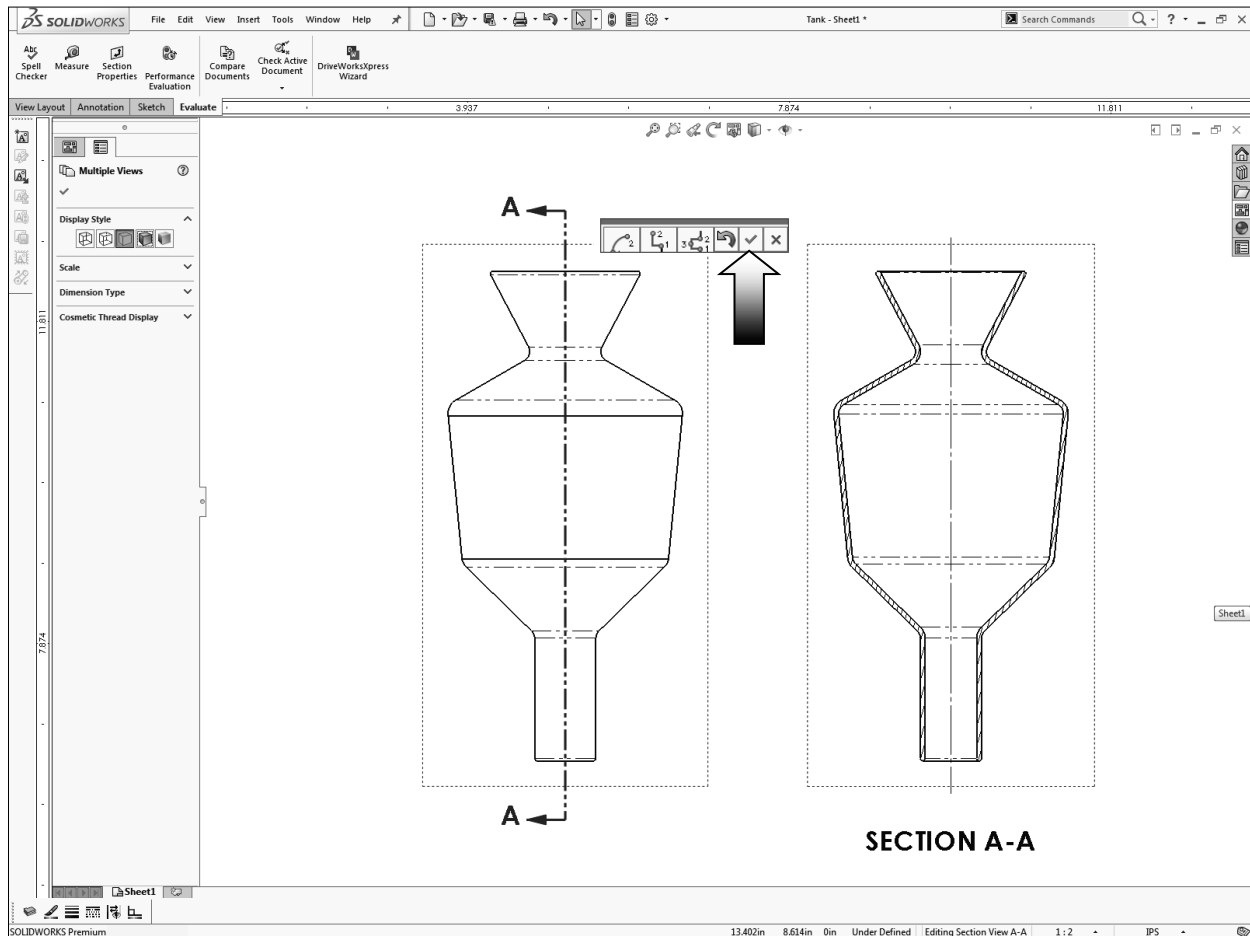
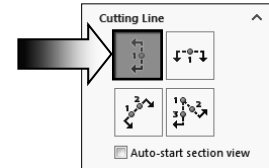
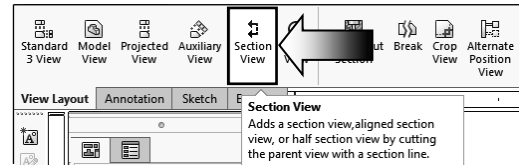

- Place the section view to the right side of the Front view.
- Move the Isometric view to the far right hand side. This view is for reference use only.

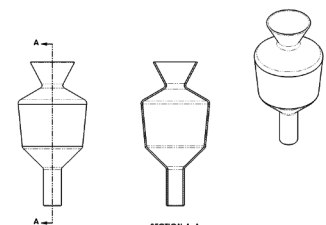

6. Measuring the surface area:

- Zoom in on the section view; we will need to select the sectioned surfaces and measure the total area.

- Change to the **Evaluate** tool tab and select the **Measure** command.

- Hold the Control key and select the 2 sectioned faces as noted.

- Locate the **Total Area** measurement and enter it here:

_____ Inches².

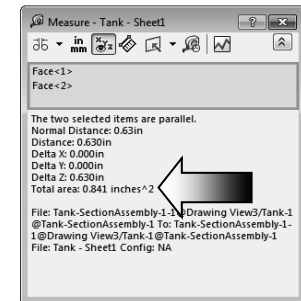
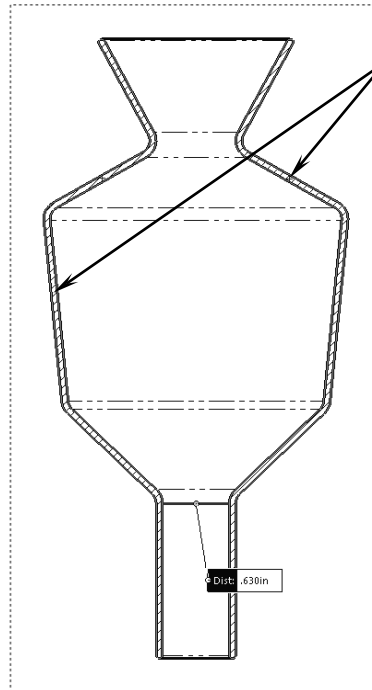
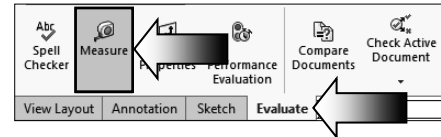

7. Creating an aligned section view:

- Double click the dotted border of the Front view to lock it.
- The Lock View Focus option allows you to add sketch entities to a view, even when the pointer is close to another view. You can be sure that the items you are adding belong to the view you want.
- Switch to the **Sketch** tool tab and sketch **2 Lines** as shown.
- Add the vertical and horizontal dimensions to fully define the sketch.

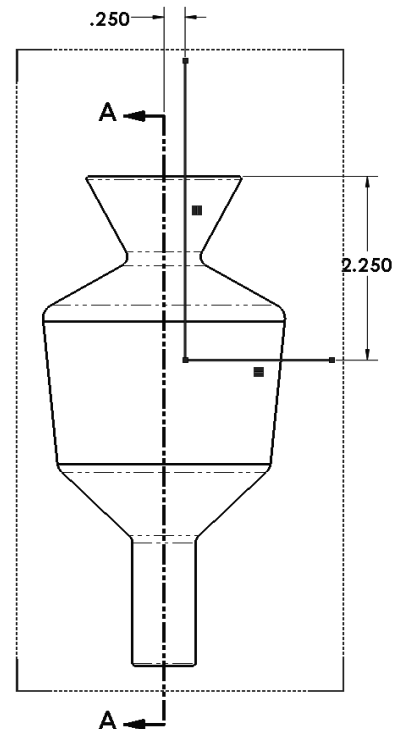

SOLIDWORKS 2019 | CSWP Advanced | Drawing Tools

- Multiple lines are normally used to create an Aligned Section View.
- Hold the **Control** key and select the Vertical Line 1st, and then select the Horizontal Line after.
- Switch to the **View Layout** tab and select the **Section View** command (arrow)

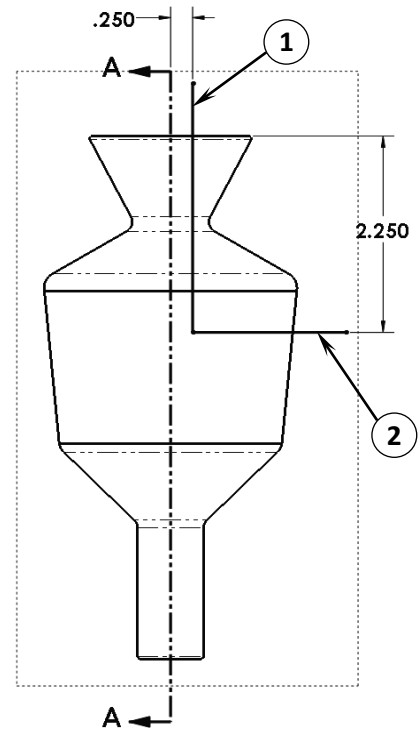
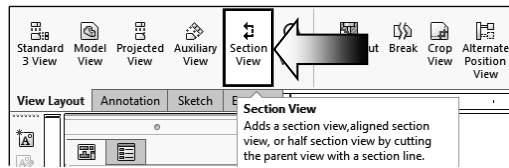

- An Aligned Section View is created and labeled as Section B-B.
- Be sure the Direction Arrows match the image shown below. Click the **Flip Direction** button if needed (arrow).

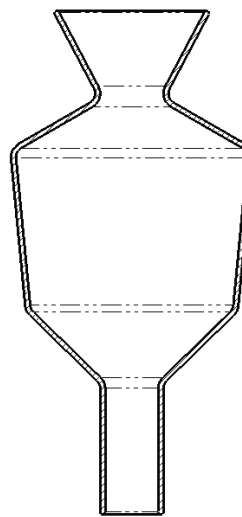
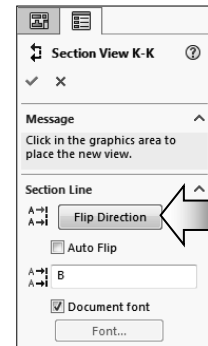
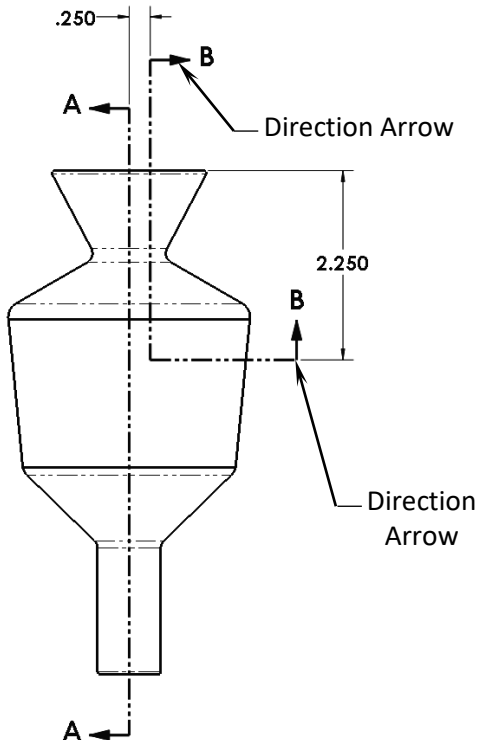

SECTION A-A

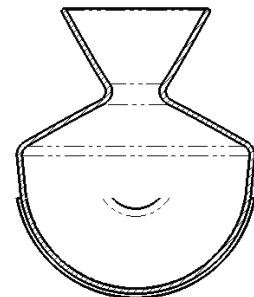

SECTION B-B

8. Measuring the surface area:

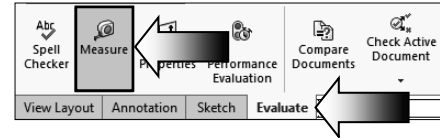

- Zoom in on the section view; we will need to select the surface of the Section B-B and measure its area.

- Change to the **Evaluate** tool tab and select the **Measure** command.

- Select the sectioned face as noted.

- Locate the **Area** measurement and enter it here:

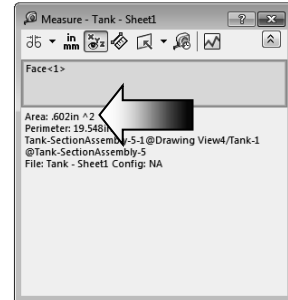
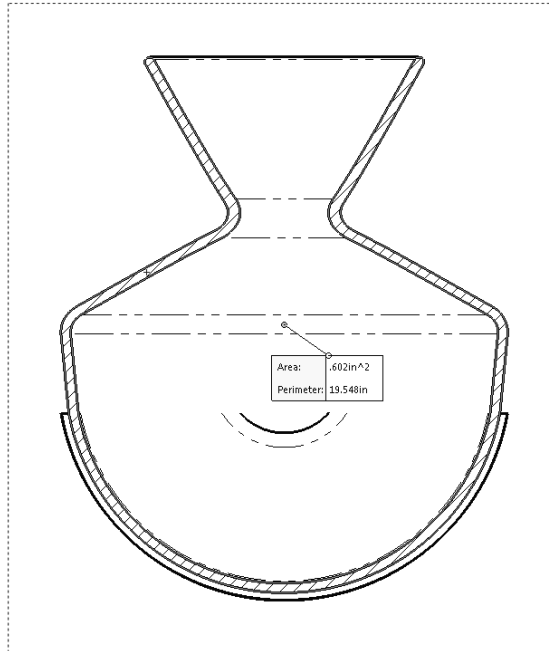

_____ Inches².

9. Saving your work:

- Select **File / Save As**.
- Enter **Tank.slddrw** for the file name.
- Click **Save**.

Summary:

The key features to Challenge 1 are:

- Creating the **Section Views** and **Measuring the total surface areas** of the sectioned surfaces.

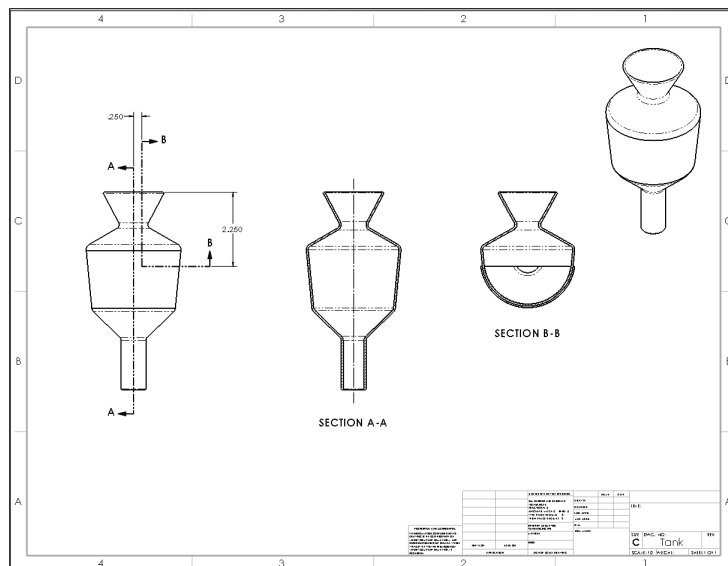

CHALLENGE 2

1. Opening an assembly document:

- Select **File / Open**.
- Browse to the Training Folder and open the assembly document named **Piston Assembly.sldasm**.

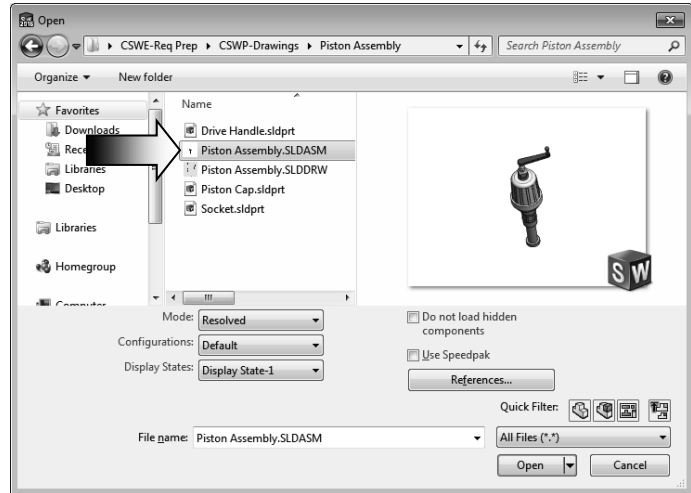

- In this Challenge, the orientation of the assembly has been changed to some oblique angle. You will need to come up with a way to find the correct angle and change the orientation of the assembly prior to making a drawing.



Top View

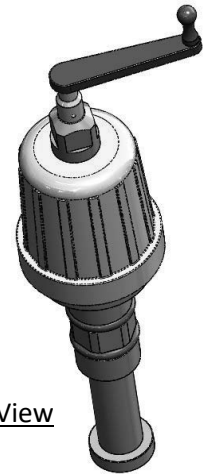

Isometric View

- Change to different view orientations such as the Front, Top, Right, and Isometric view to examine the default orientation of this assembly.

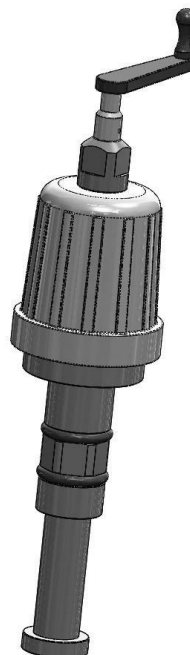

Front View

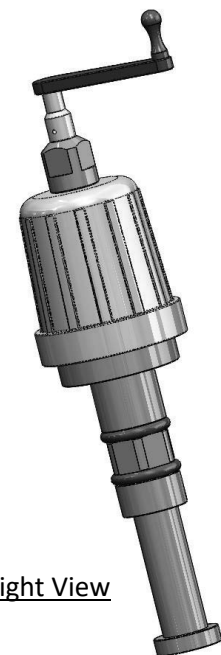

Right View

- The Top view will be used to correct the orientation of the assembly. Remain in Isometric view.

2. Creating a reference sketch:

- Open a **new sketch** on the face as indicated.
- We will need to rotate the Handle to the horizontal position. There are several methods to find the current angle of the Handle but we will go with creating a reference sketch approach.
- Sketch a centerline that is **coincident** with the **2 centers** of the crank handle.

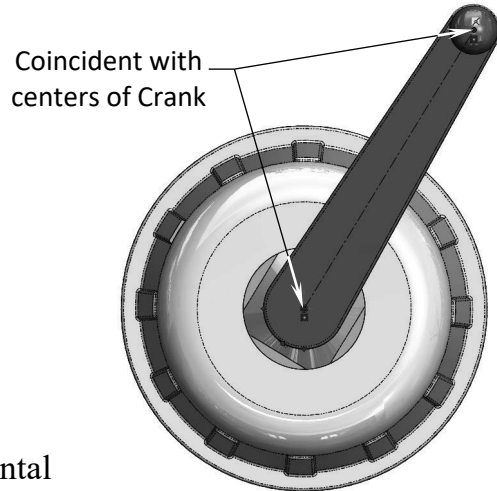
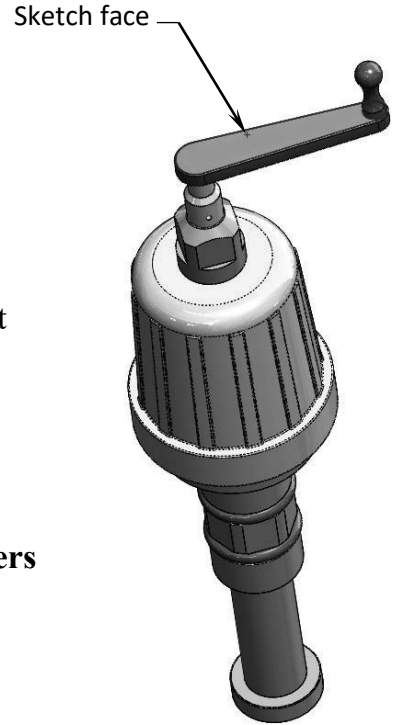

- Sketch a horizontal **centerline** and **delete** the Horizontal relation, so that we can add the angular dimension without over defining the sketch.

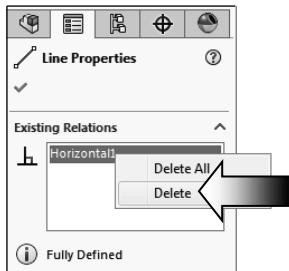
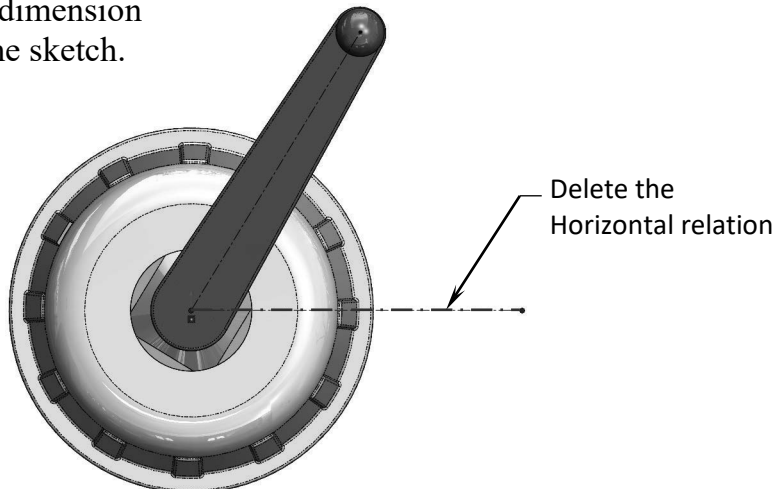

SOLIDWORKS 2019 | CSWP Advanced | Drawing Tools

- Add an angular dimension as shown to fully define this sketch.

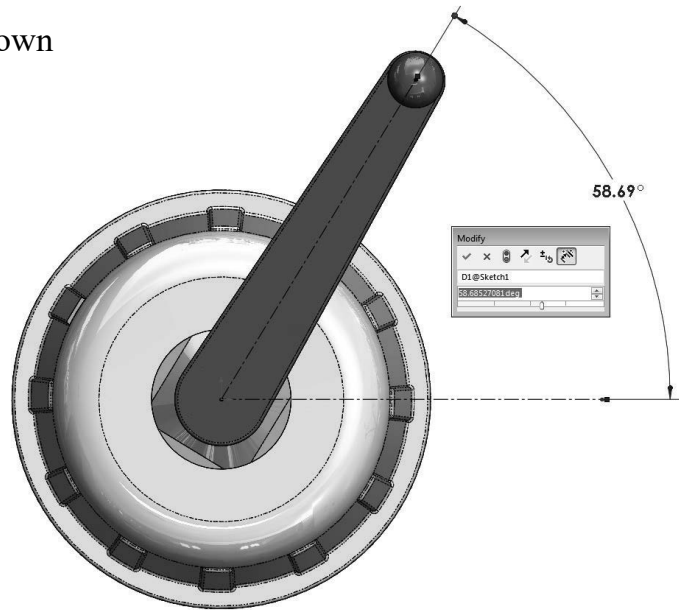

- Keep the default dimension value at **58.685°**.

- Highlight the angular dimension and press **Control+C** to copy it to the clipboard.

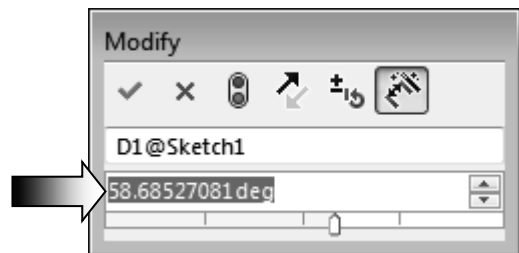

3. Modifying the view angle:

- Click the **Option** button or select **Tools / Options**.
- Select the **View** option (arrow) and change the angle of the Arrow Keys to **58.685°**.

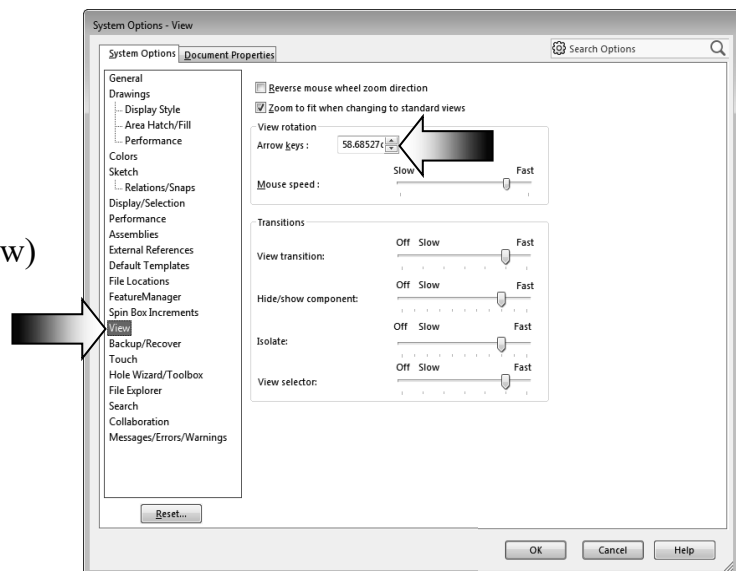
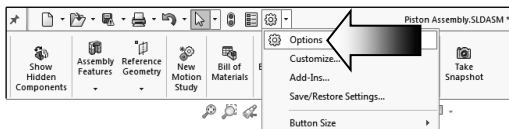

SOLIDWORKS 2019 | CSWP Advanced | Drawing Tools

- The upper surface of the Crank Handle should be rotated to a flat position first.

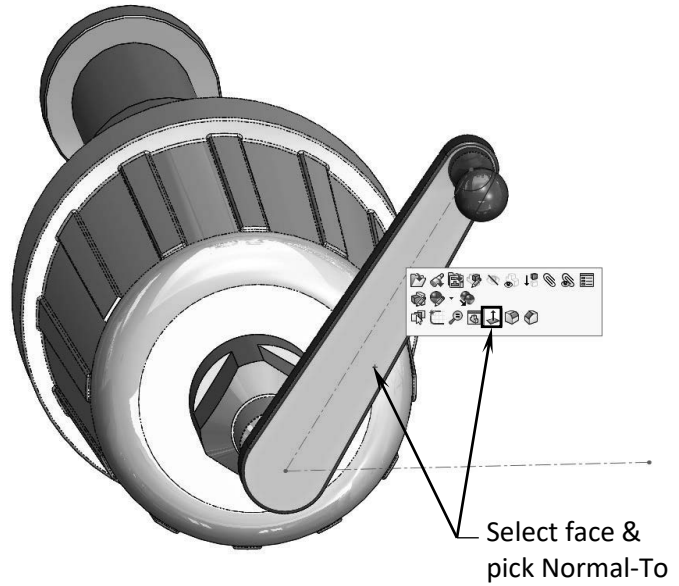

- Click the face as noted and select **Normal-To** (arrow). This option rotates the selected face perpendicular (flat) to the screen.

- Hold the **Alt** key and press the **Left arrow** once, to rotate the view **58.685°** downward.

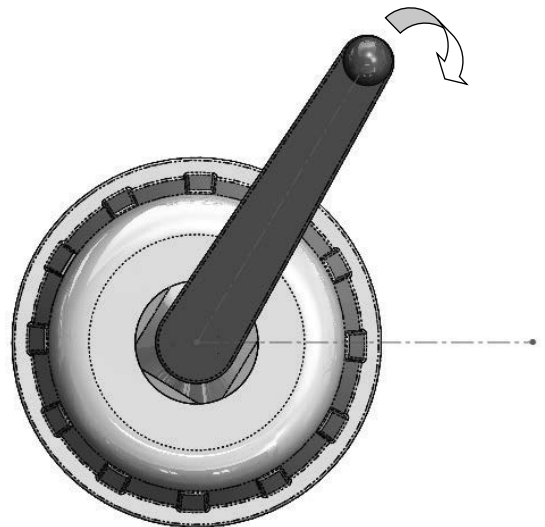

- The Crank Handle and its assembly is now rotated to a horizontal position.

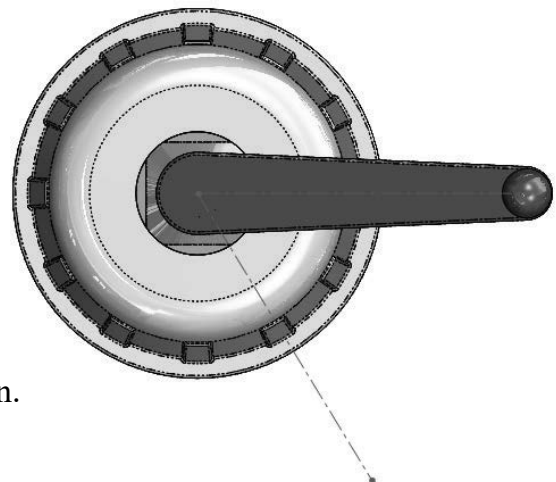

- We will save the new position as a named-view, or a custom view so that we could retrieve it in the drawing later on.

4. Saving a new named-view:

- Custom views can be created and saved in the model or in an assembly so that they can be displayed in a drawing.

- The views are saved in the Orientation dialog and get carried over to the drawing and listed on the Properties tree.

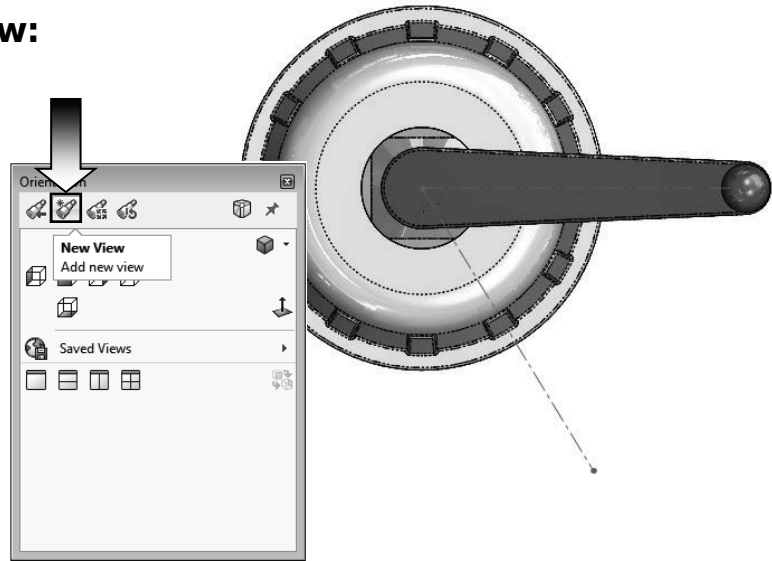

- Press the **Spacebar** to bring out the Orientation dialog.

- Click the **New View** button .

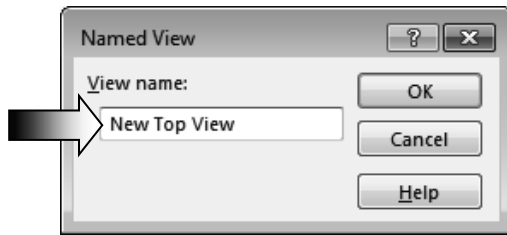

- Enter: **New Top View** in the Named View dialog and press **OK**.

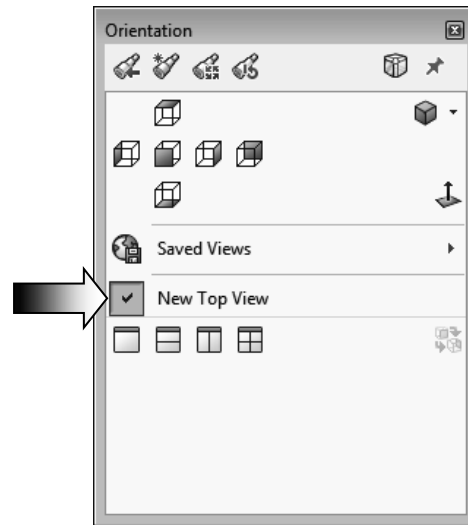



- The new view is saved and displayed in the Orientation dialog.

- It would be much more difficult to use the original orientations to create the new drawing views in a drawing. The **New Top View** will be used to create the other drawing views by projecting them along the vertical or horizontal directions.

5. Making a drawing from assembly:

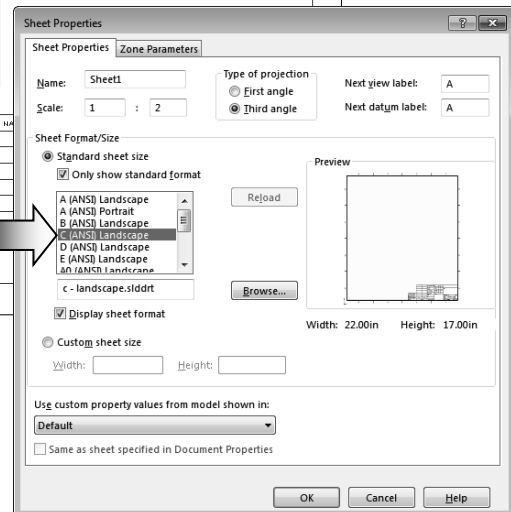
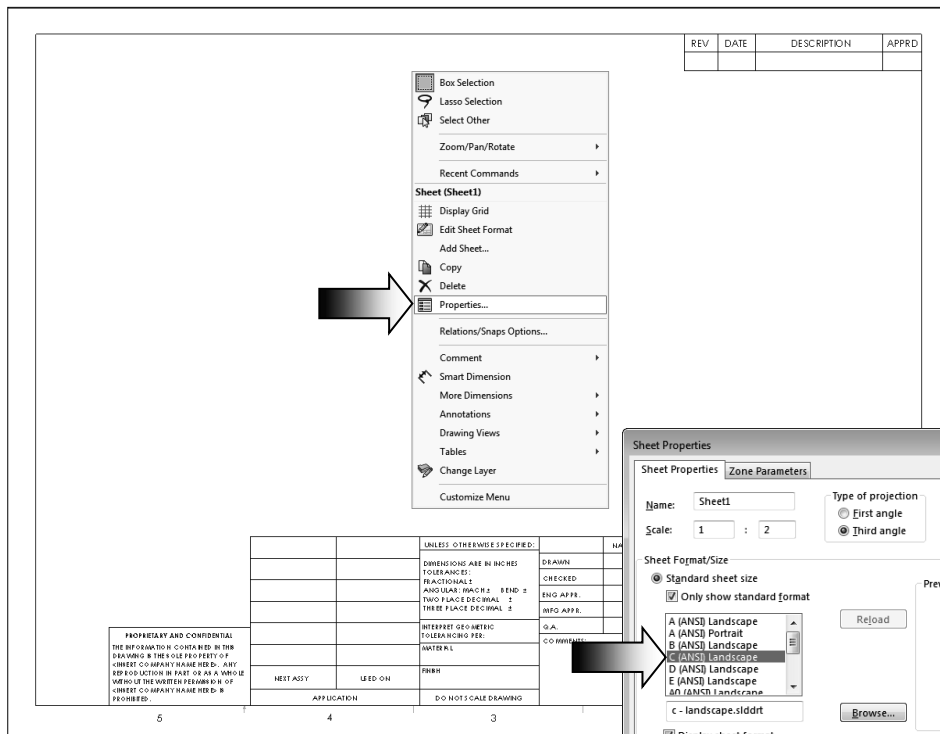
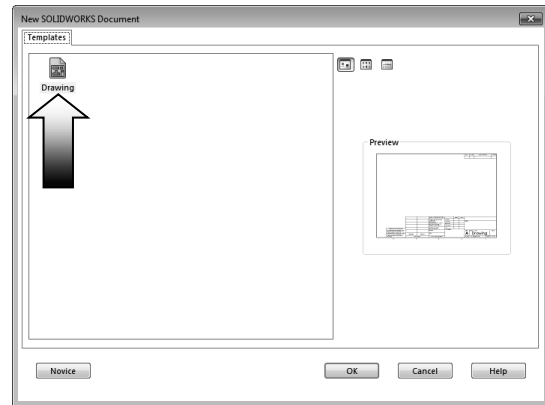
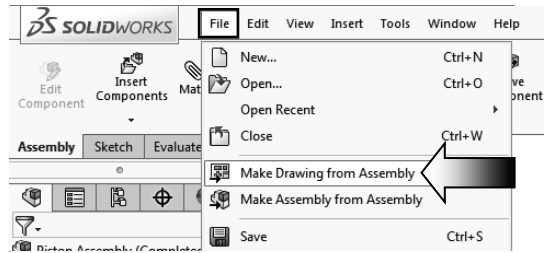
- Select **File / Make Drawing from Assembly** (arrow).
- Select the **Drawing** template.
- The default drawing (A-Size) is displayed. Right click inside the drawing and select **Properties**.
- Change the paper size to **C-Landscape**.
- Change the **Scale** to **1:2**.



- Set the Type of Projection to **Third Angle**.
- Click **OK** .

6. Adding the first drawing view:

- Drag and drop the **Top** view from the View Palette (change scale to 1:2 if needed).

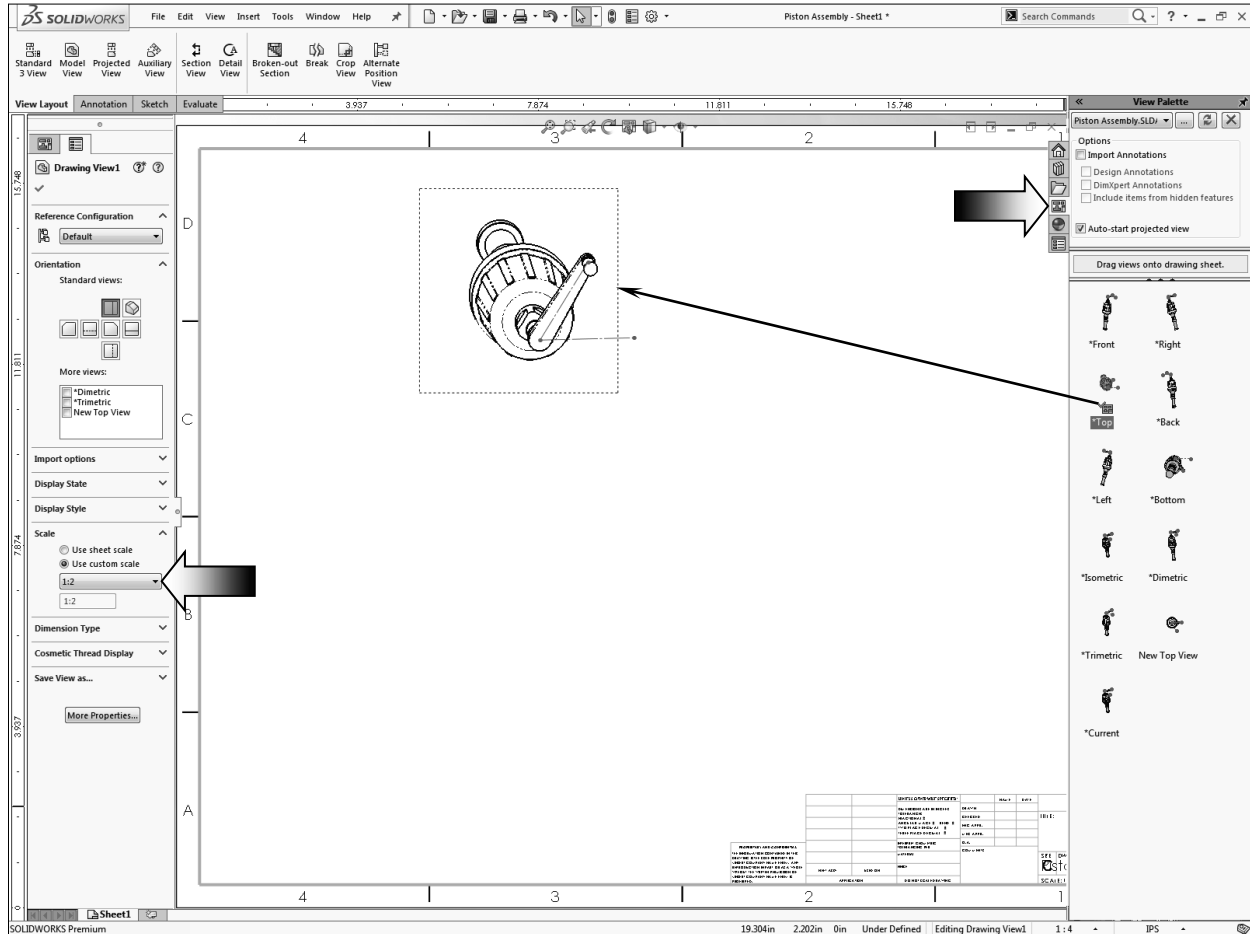

- Locate the **Orientation** section on the Properties tree.

- Enable the named-view **New Top View** check box.

- Click **OK**.

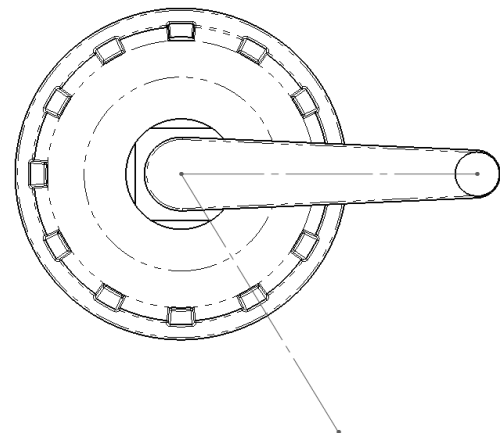
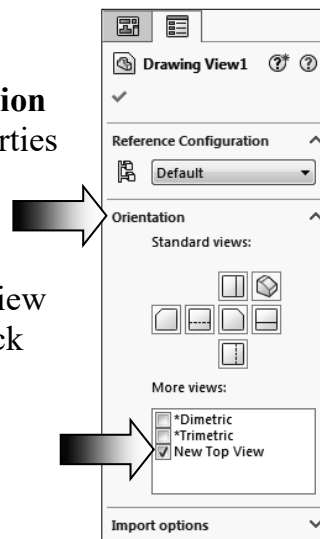

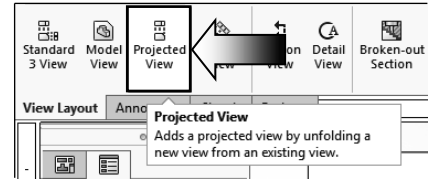

7. Creating the projected drawing views:

- New drawing views can now be projected vertically or horizontally from the new view.

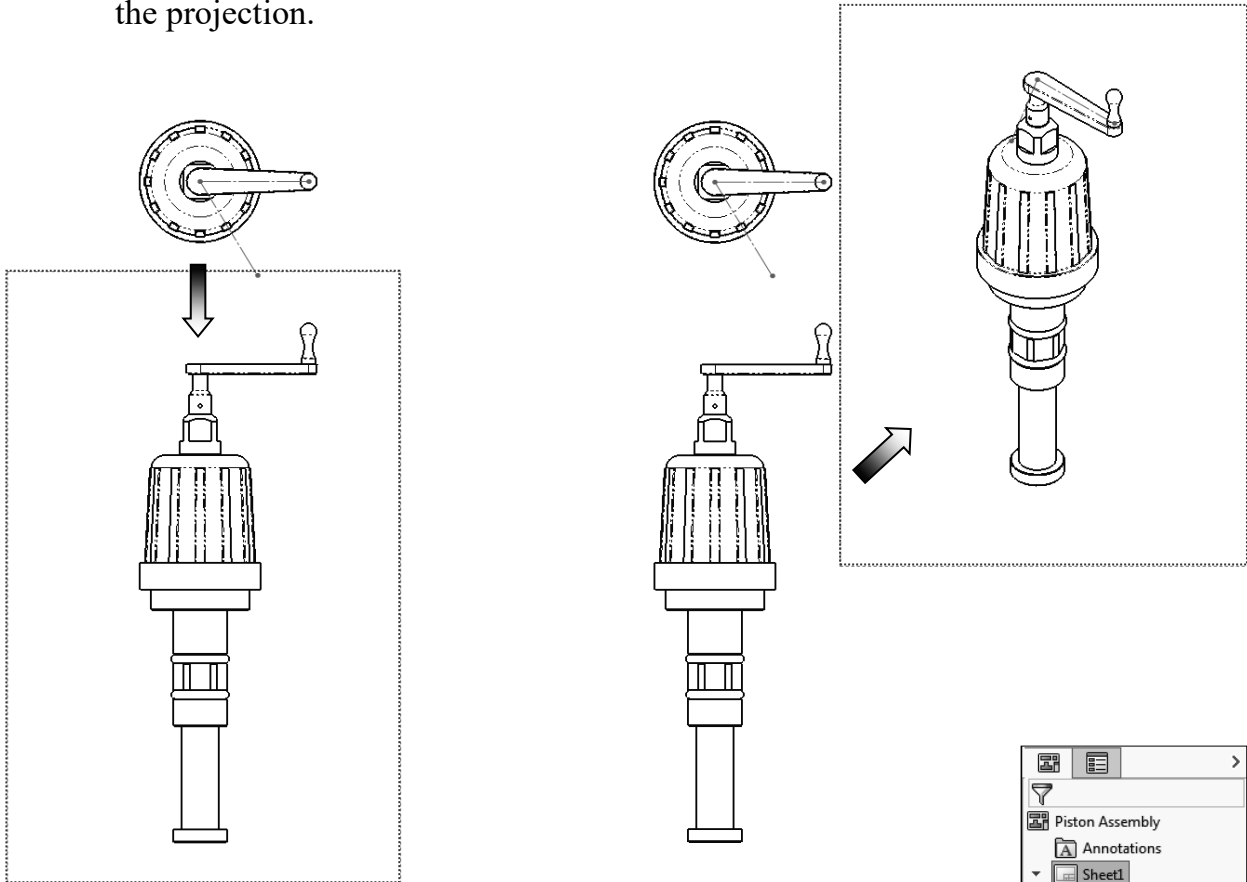

- Switch to the **View Layout** tool tab and click the **Projected View** command .
- Select the dotted border of the **Top** view to start the projection.



- Move the mouse cursor downward to see the preview of the Front view. Place the Front view under the Top view approximately as shown.
- Additionally, create an isometric view and position it similar to the one shown above.
- Locate the **Sketch1** from the Drawing tree and **Show** it .

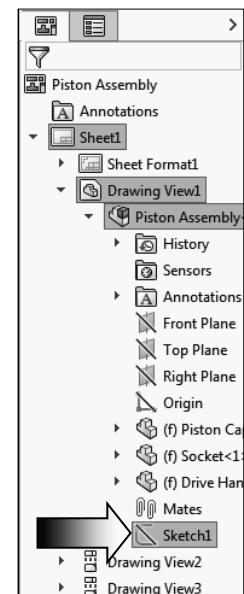

8. Adding reference lines:

- Zoom in on the lower left corner of the drawing and select the **Line** command from the Sketch tool tab.
- Right click on the dotted border of the Front view and select **Lock View Focus**. This will make the new lines a part of the view. When the drawing view is moved, the lines will also move.

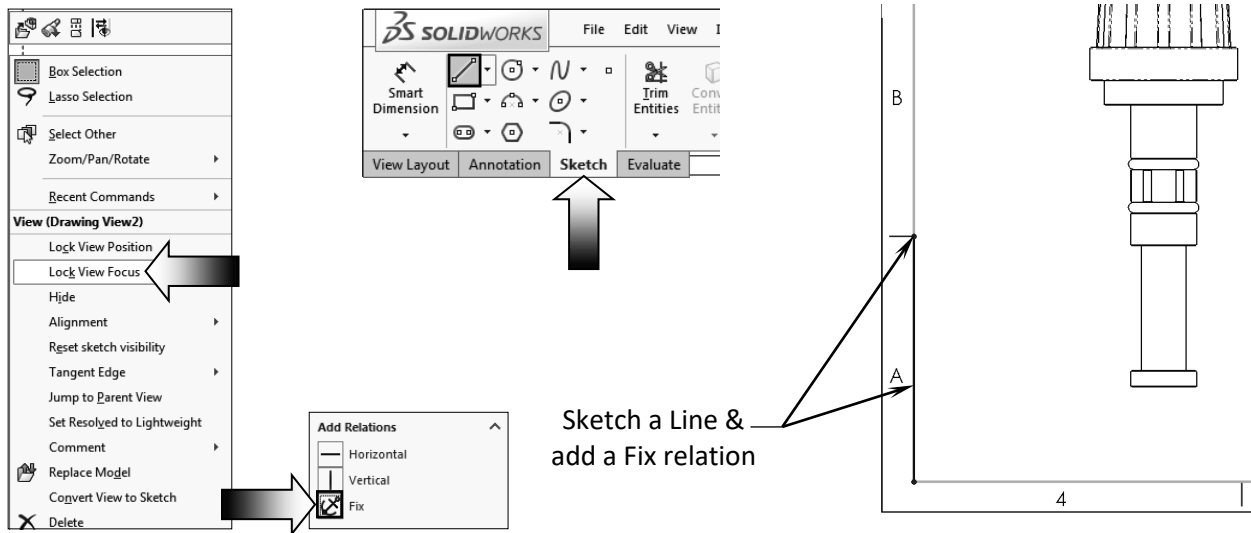

- Sketch a **vertical line** starting at the lower left corner of the border.
- Add a **Fix relation** to the line so that it will not move.
- Sketch the **second line** to the right side of the first line approximately as shown.
- Add the **5.00 inches** spacing dimension between the 2 lines.

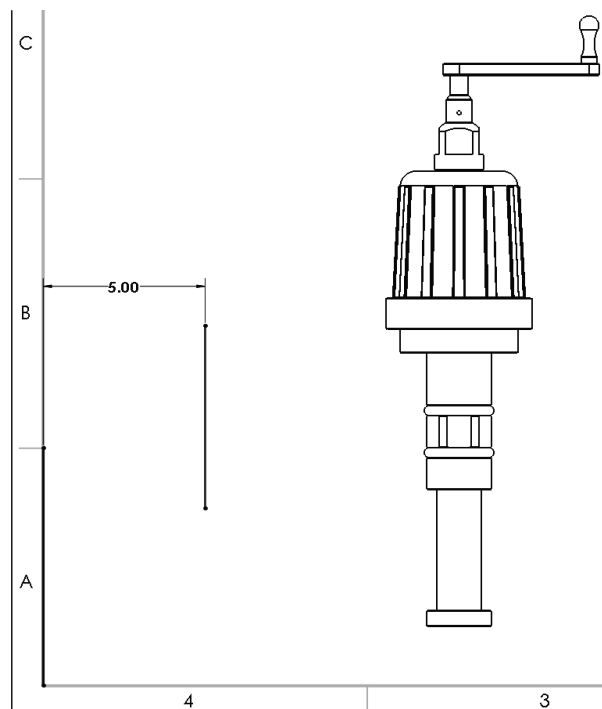

9. Converting an entity:

- Remain in the **Lock View Focus** Mode; this way the next entity will get converted into a line and belongs to the View, not the Sheet.
- Select the vertical edge as noted and press the **Convert Entity** command from the Sketch tool tab.
- The selected edge is converted to a line. When the drawing view is moved, the line will move along.

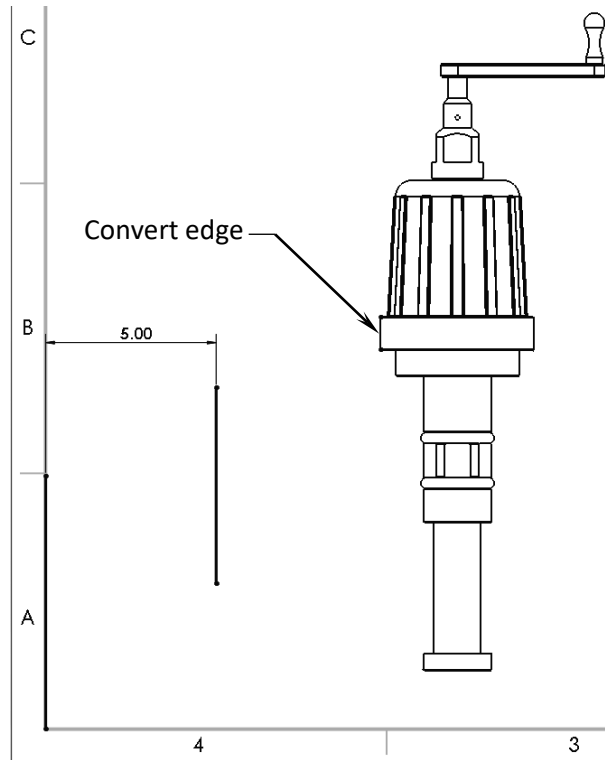

10. Adding a reference dimension:

- The question is: how can we create a dimension between a line and an edge of a drawing view?
- There are several ways to achieve this, and one approach is to lock the View-Focus and add the reference lines.
- Add a **Driven** dimension as shown.
- Enter the dimension value here:

_____ inches.

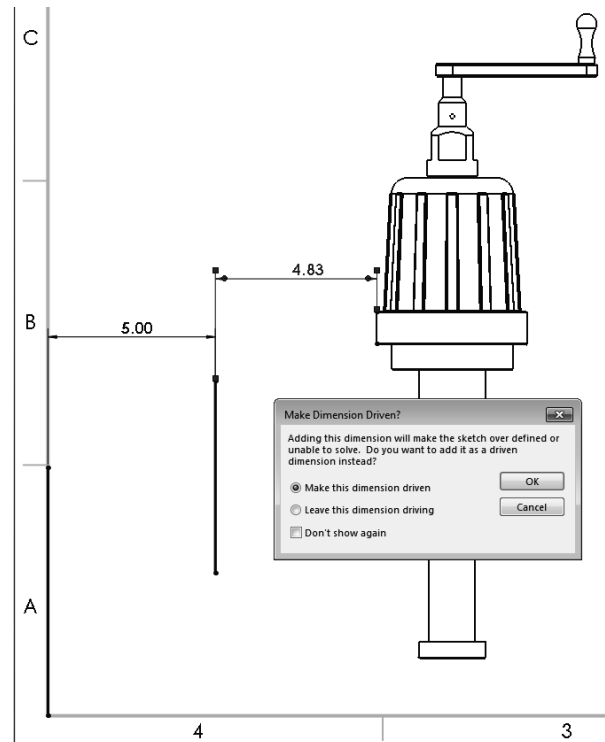

11. Adding a Top drawing view:

- Expand the **View Palette**.
- Drag and drop the **Top** drawing view approximately as shown below.

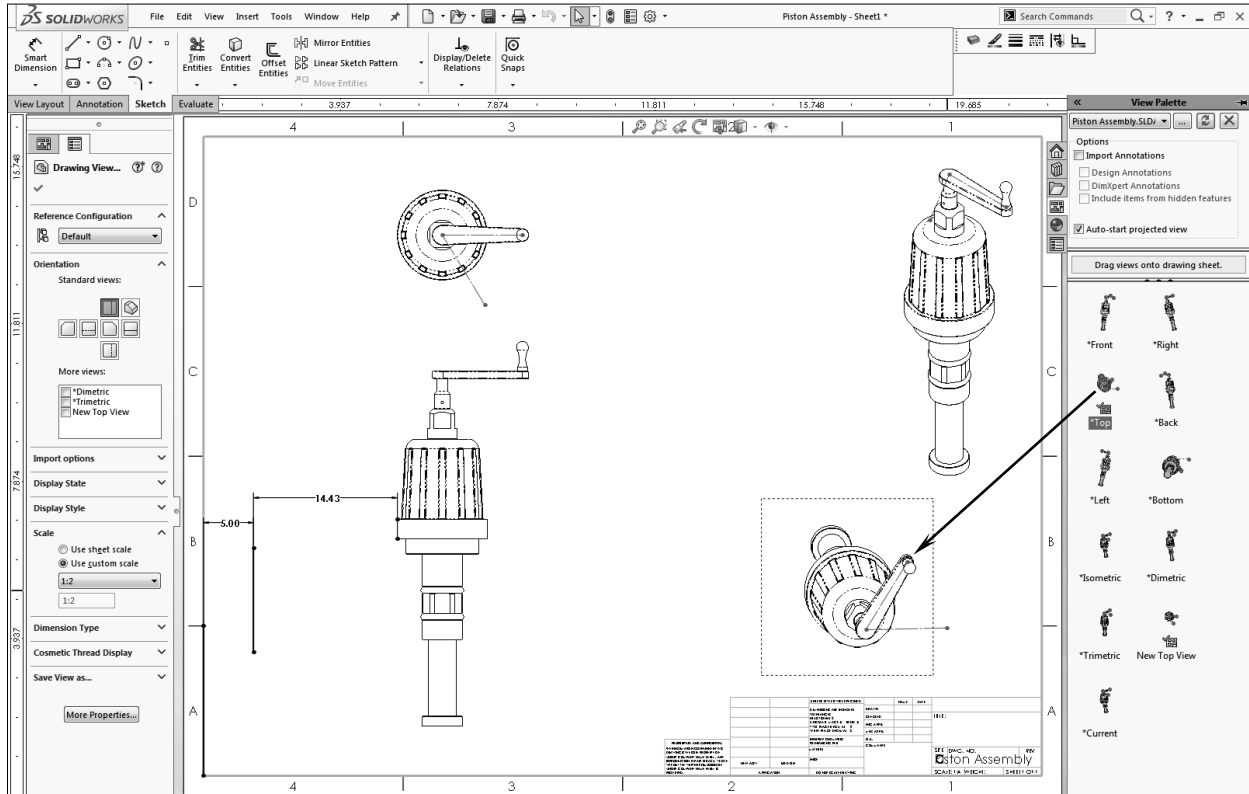

- Switch to the **Sketch** tab and sketch a **line** to the left side of the drawing view as shown.
- Add a **Parallel** relation between the sketch line and the centerline in the middle of the crank handle.
- This line will be used to create a Section view in the next step.

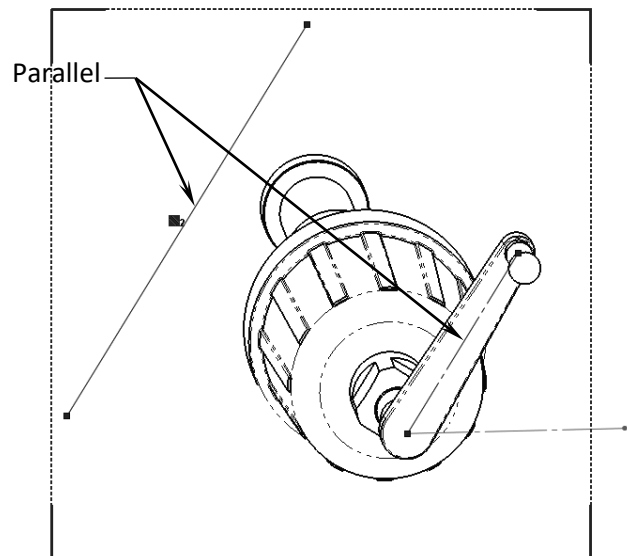

- Click the **Section View** command (arrow) from the **View Layout** tab.

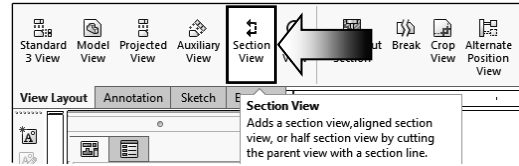

- Place the section view on the upper left side of the Top view.

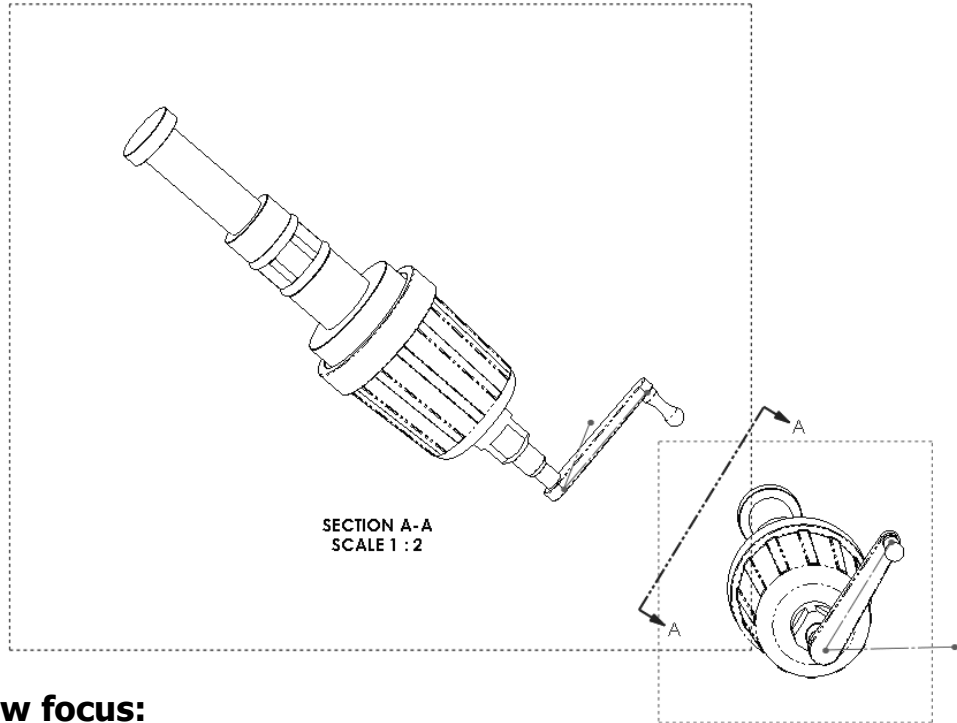

12. Locking a view focus:

- Use **Lock-View-Focus** to keep a drawing view active while adding other reference geometry.

- The reference geometry can be measured to and from the geometry of the drawing view.

- Right click the border of the new View; select **Lock View Focus**.

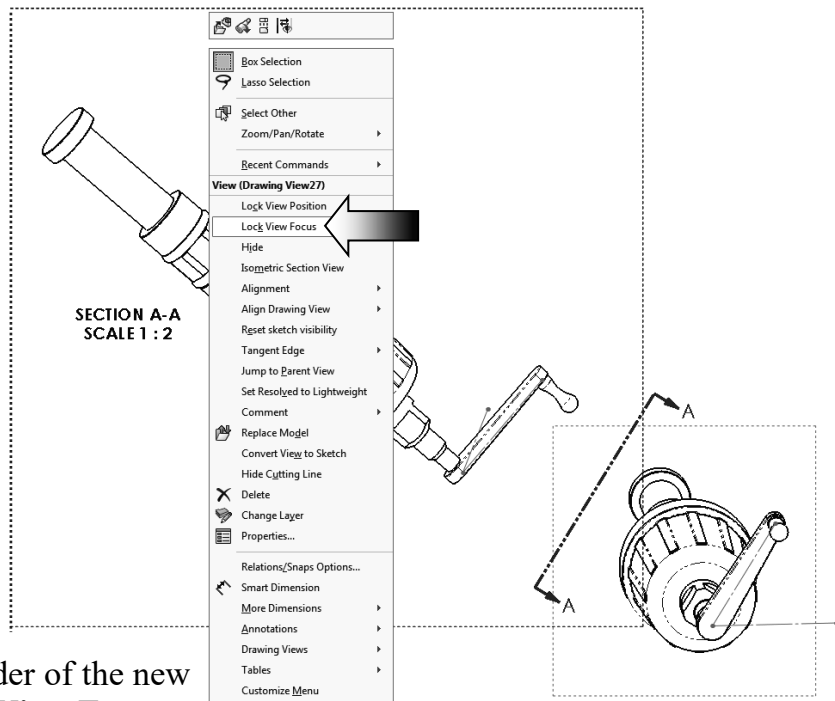

- Sketch a new **Line** approximately as shown below.

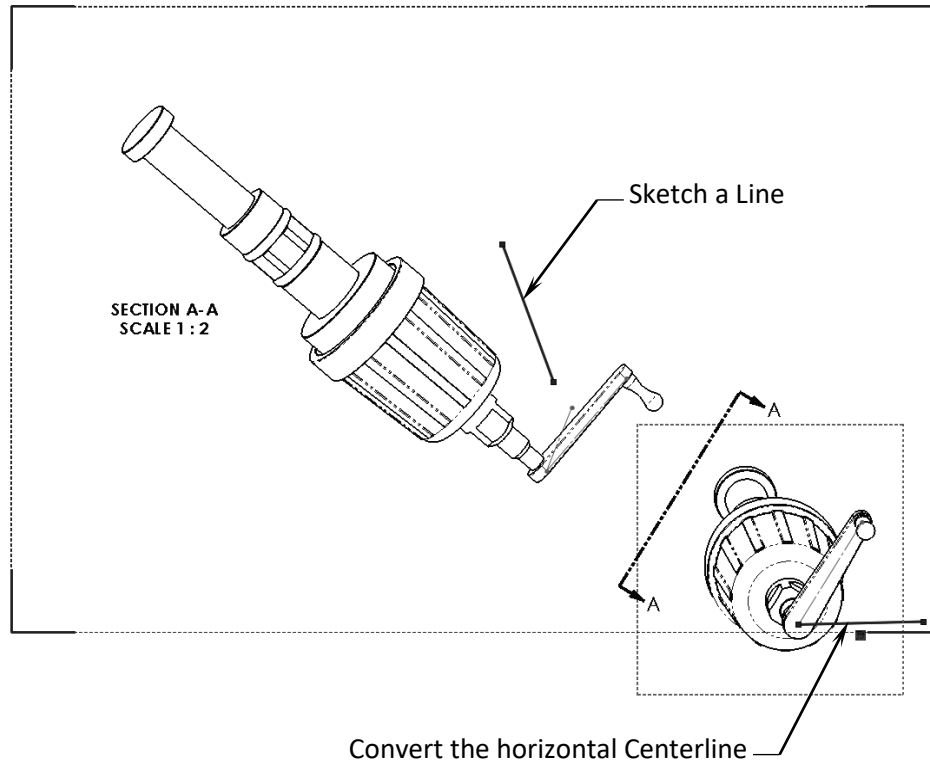

- Select the horizontal centerline and press **Convert Entities**  .

- Add the two dimensions shown.

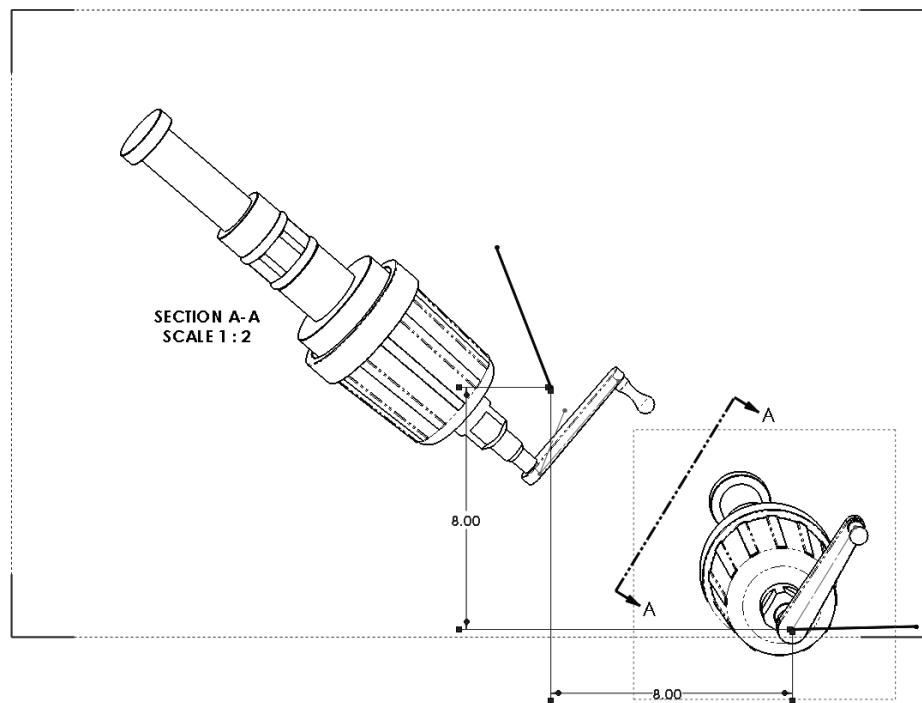

- Attach the dimensions from the left end of the converted line to the bottom endpoint of the sketched line.

13. Adding an angular dimension:

- The angular dimension will be used as the answer for this question.
- Add an angular dimension between the sketched line and the left-most edge of the crank handle.

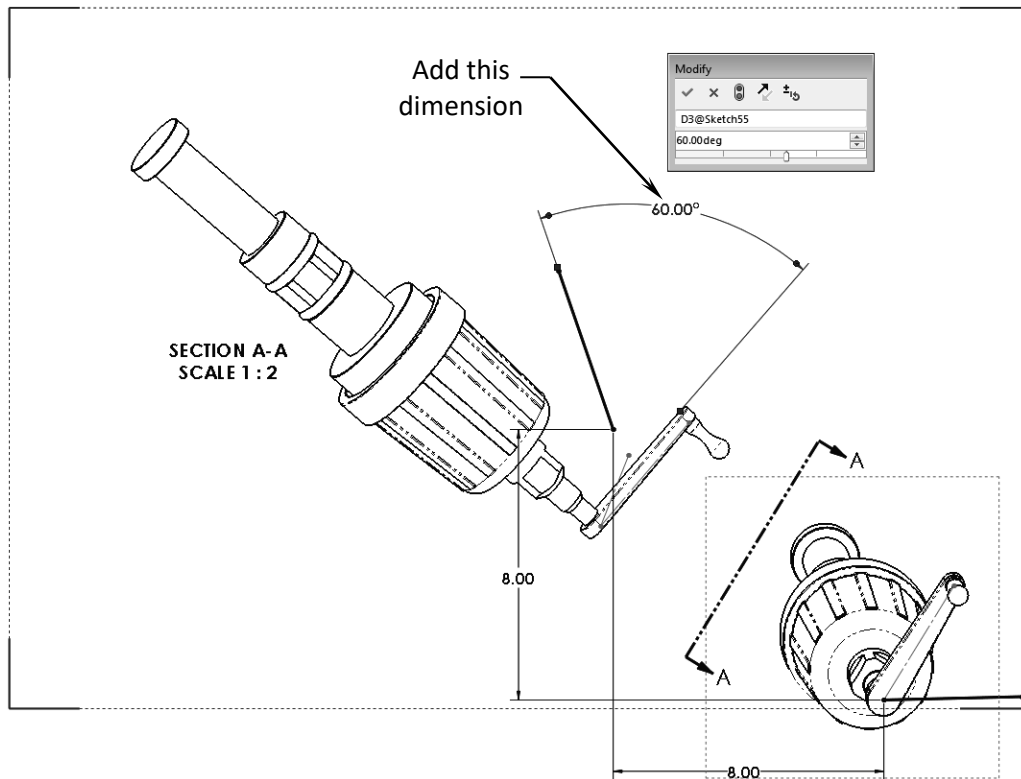

- Enter the **dimension value** here:

_____ degrees.

Summary:

The key features to Challenge 2 are:

- Creating the drawing views and finding the right orientations to assist with creating the other drawing views.
- Lock and Un-lock the View Focus so that reference geometry can be added for measuring and locating other references.

CHALLENGE 3

1. Opening an assembly document:

- Select **File / Open**.
- Browse to the Training Folder and open the assembly document named **Radial Stretcher.sldasm**.

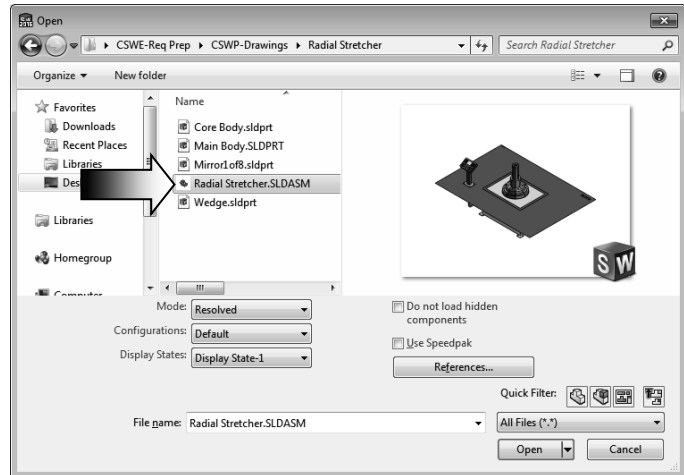

- This challenge examines your skills on the following:
 - * Creating an assembly drawing.
 - * Adding balloons.
 - * Customizing a bill of materials.

2. Transferring to a drawing:

- Select **File / Make Drawing from Assembly** (arrow).

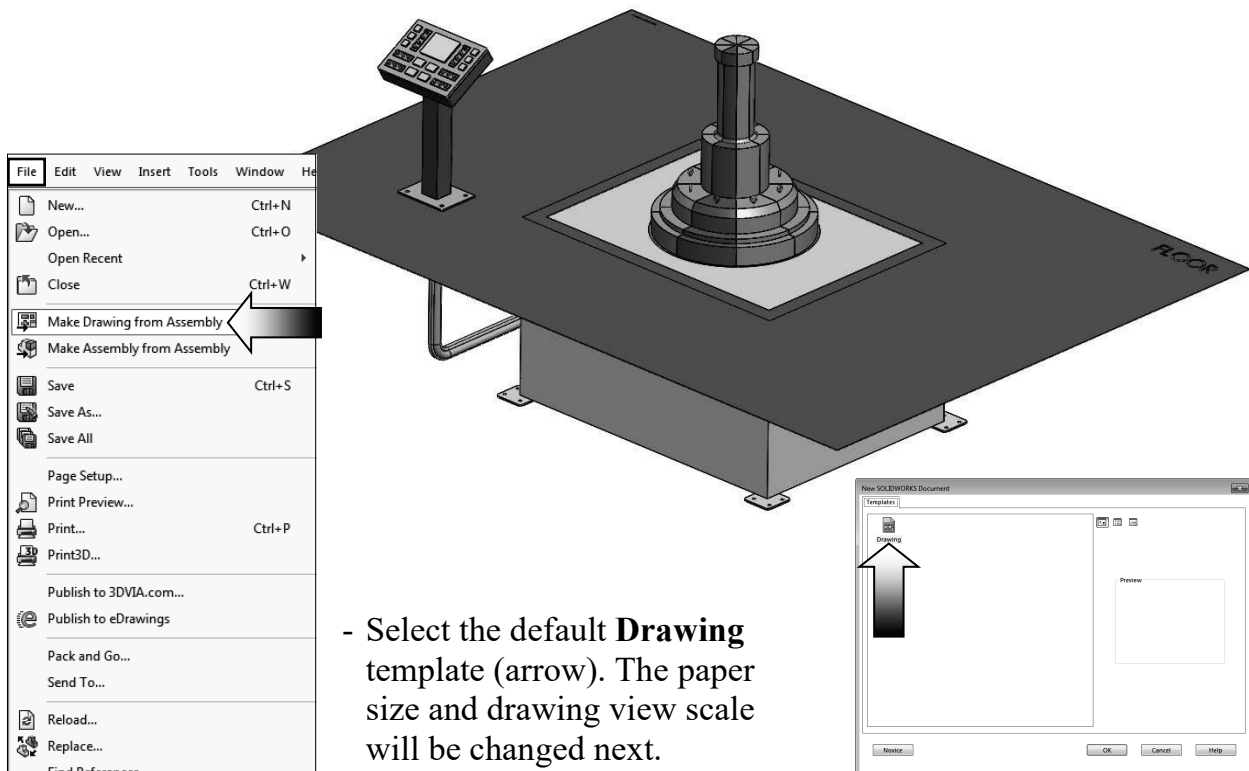

- Select the default **Drawing** template (arrow). The paper size and drawing view scale will be changed next.

SOLIDWORKS 2019 | CSWP Advanced | Drawing Tools

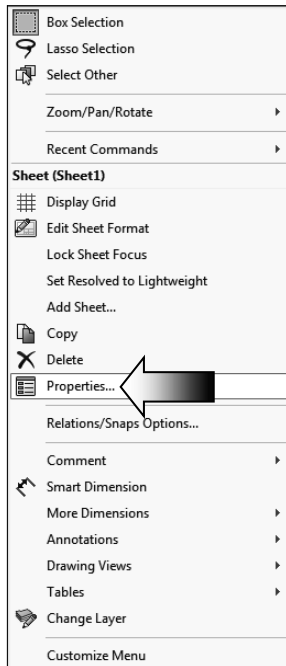

- Right click inside the drawing and select **Properties**.

- Set the following:

* **Scale: 1:32**

* **Third Angle**

* **C (ANSI) Landscape**

- Click **OK**.

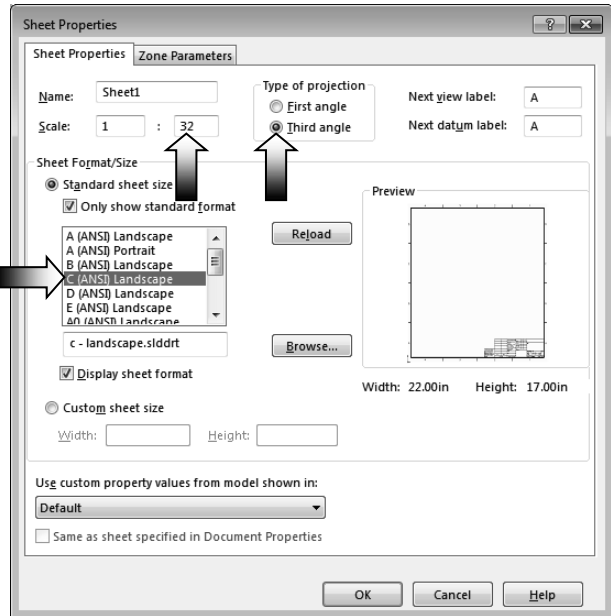

3. Adding drawing views from the View Palette:

- Expand the **View Palette** and drag/drop the **Isometric Exploded View** to the drawing.

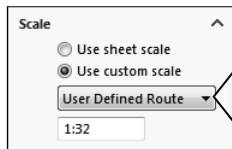

- Locate the **Scale** option and set it to **Use-Custom-Scale 1:32**.

- Click **OK**.

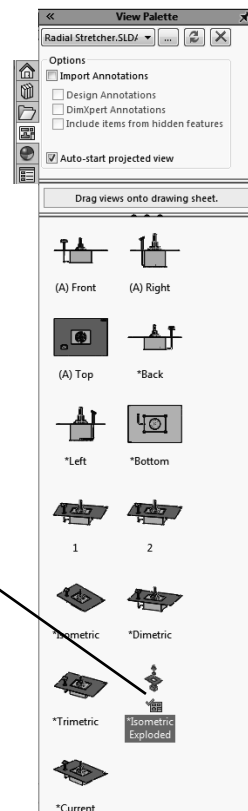
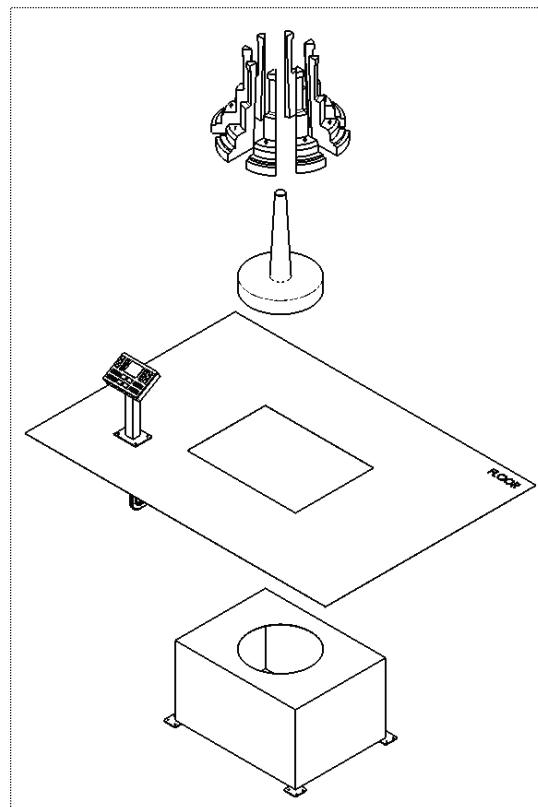

- Next, drag and drop the **Isometric View** also from the View Palette. The drawing view is aligned horizontally with the first view by default.

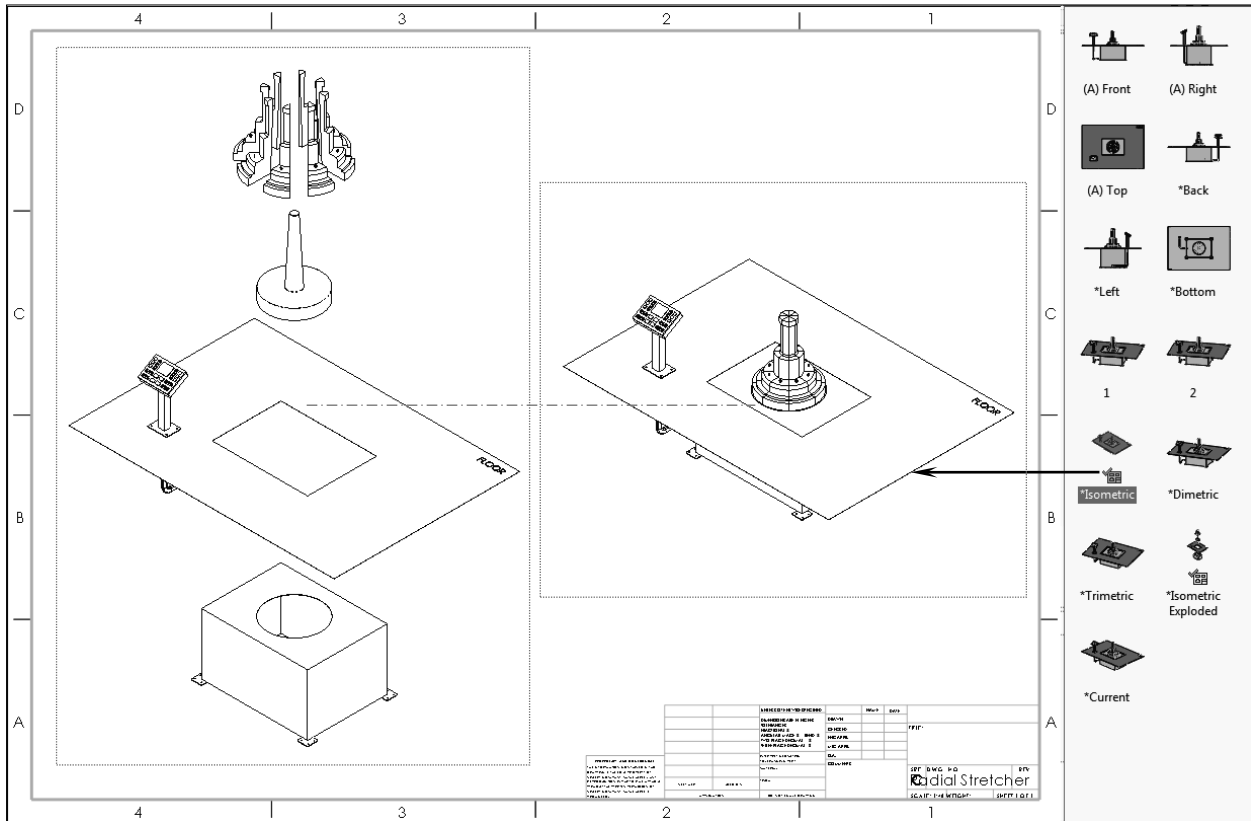

4. Breaking the view alignment:

- Right click the Isometric view's border and select **Alignment / Break-Alignment.**

- The isometric view can now be moved freely. Move it to the upper right side.

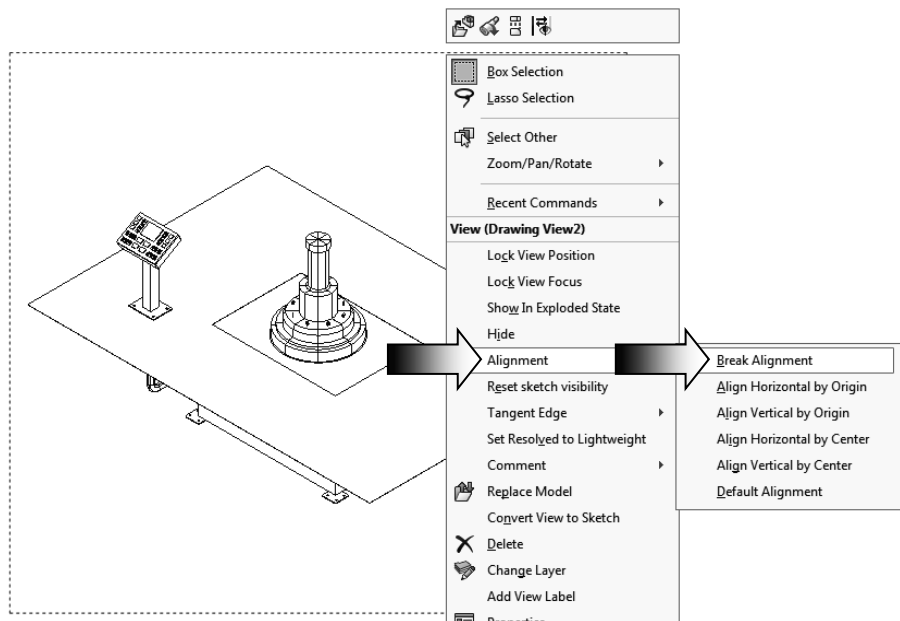

5. Adding balloons:

- Balloons are used to identify the item numbers in the bills of materials.

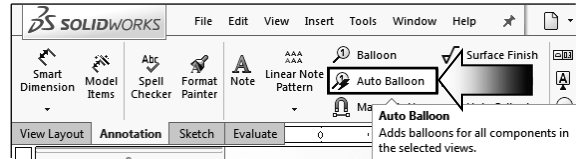

- Switch to the **Annotation** tab and click the **Auto Balloon** command  .

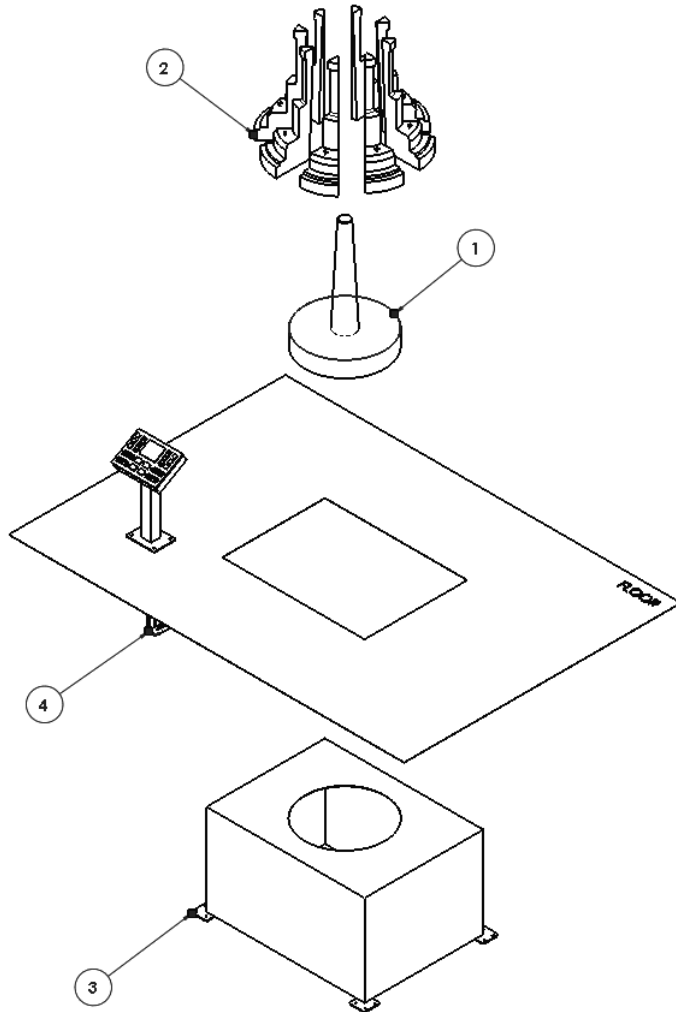
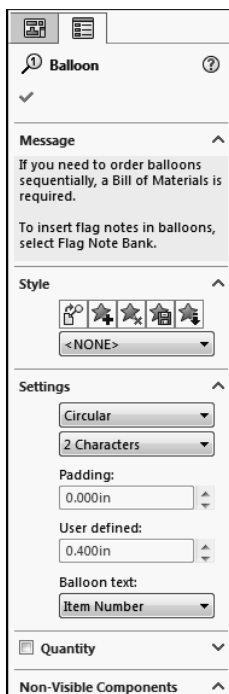

- By default, each unique component gets a balloon assigned to it automatically. Change the balloon settings to **Circular, 2 characters** and click **OK**.

- The item numbers reflect the order of the components listed in the top level assembly. Changes done to the order of the components in the assembly design tree will populate to the balloons and the bill of materials.

6. Adding a bill of materials:

- In an assembly drawing a bill of materials is created to display the item numbers, quantities, part numbers, and custom properties of the assembly.
- From the Annotation tab, select **Tables / Bill of Materials**.

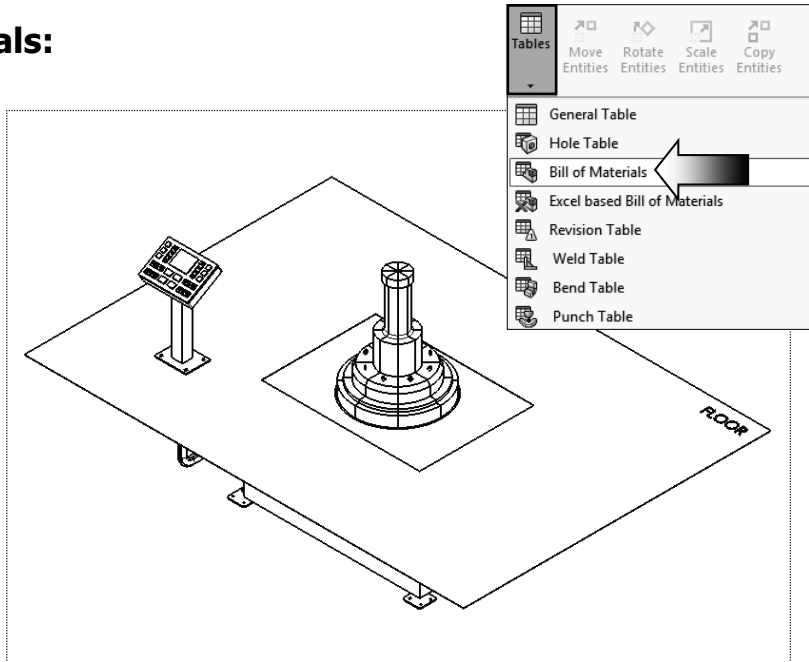

- In the BOM Type, select the option **Parts Only** (arrow).

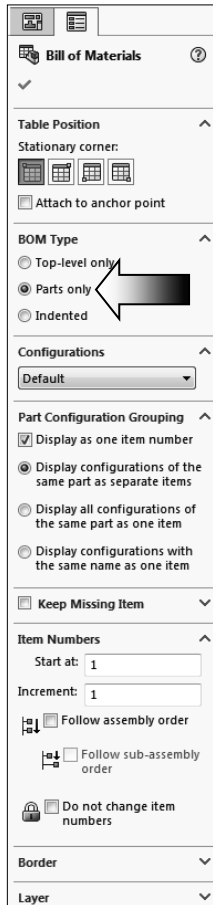

- Click **OK**.

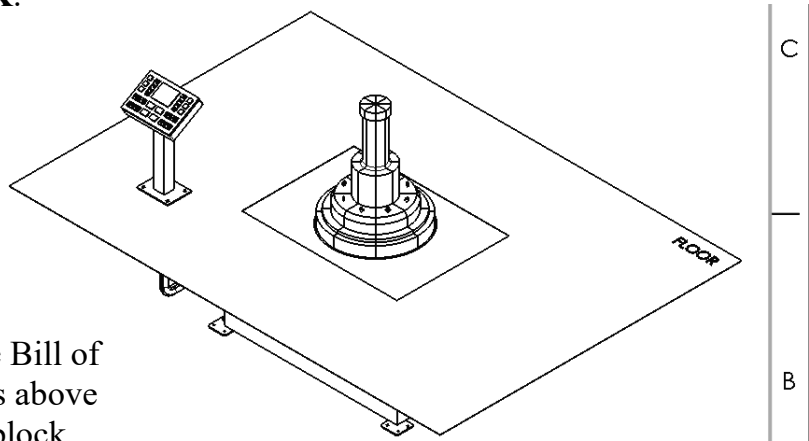

- Place the Bill of Materials above the title block.
- The table will be modified to include some custom properties in the next couple steps.

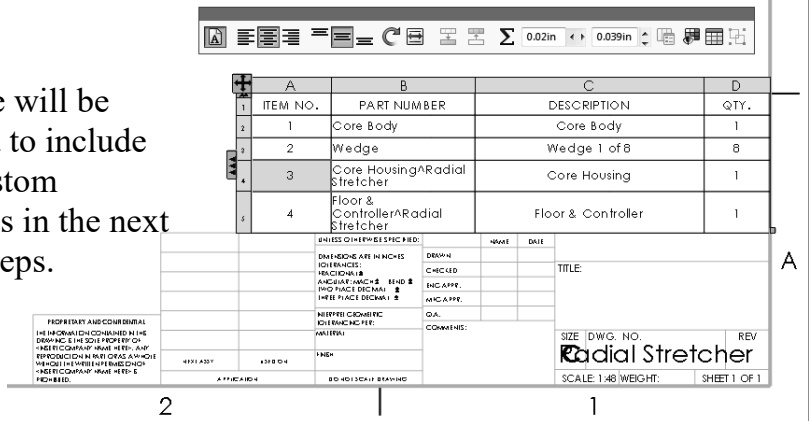

SOLIDWORKS 2019 | CSWP Advanced | Drawing Tools

ITEM NO.	PART NUMBER	DESCRIPTION	QTY.
1	Core Body	Core Body	1
2	Wedge	Wedge 1 of 8	8
3	Core Housing^Radial Stretcher	Core Housing	1
4	Floor & Controller^Radial Stretcher	Floor & Controller	1

- Zoom in on the Bill of materials. We will change the Part Number column to include the actual part numbers that were assigned earlier from the part level.

7. Changing custom properties:

- Double click the column header **B** to access the Custom Property options.

	A	B	C	D
1	ITEM NO.	PART NUMBER	DESCRIPTION	QTY.
2	1	Core Body	Core Body	1
3	2	Wedge	Wedge 1 of 8	8
4	3	Core Housing^Radial Stretcher	Core Housing	1
5	4	Floor & Controller^Radial Stretcher	Floor & Controller	1

- Change the Column Type to **Custom Property** (arrow).
- For Property Name, select **PartNo** from the list (arrow).

	A	B	C	D
1	ITEM NO.	PartNo	DESCRIPTION	QTY.
2	1	232 178 0313	Core Body	1
3	2	417902661	Wedge 1 of 8	8
4	3	424 514 6229	Core Housing	1
5	4	292 436 5662	Floor & Controller	1

- The part numbers for each component are displayed in column B.

SOLIDWORKS 2019 | CSWP Advanced | Drawing Tools

- Adjust the column width by dragging the row divider  .

Drag to adjust

ITEM NO.	PartNo	DESCRIPTION	QTY.
1	232 178 0313	Core Body	1
2	417902661	Wedge 1 of 8	8
3	424 514 6229	Core Housing	1
4	292 436 5662	Floor & Controller	1

8. Adding a new column:

- Right click the column header **D** and select **Insert / Column Right** (arrow).

	A	B	C	D
1	ITEM NO.	PartNo	DESCRIPTION	QTY.
2	1	232 178 0313	Core Body	1
3	2	417902661	Wedge 1 of 8	8
4	3	424 514 6229	Core Housing	1
5	4	292 436 5662	Floor & Controller	1

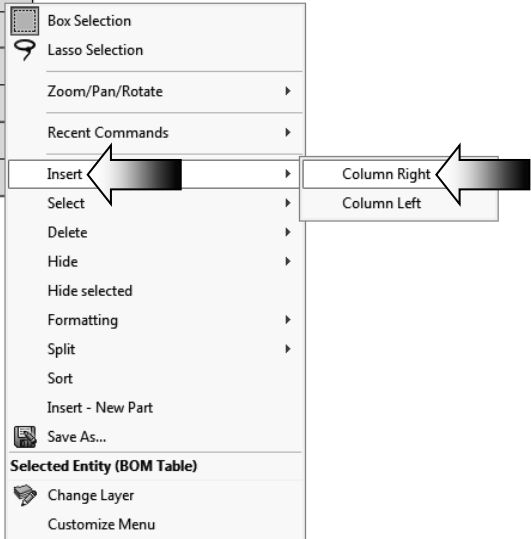

- Change the Column Type to **Custom Property**.

- For Property Name, select **Project** from the list.

- The project **Radial Stretch** is displayed in the new column.

	A	B	C	D	E
1	ITEM NO.	PartNo	DESCRIPTION	QTY.	Project
2	1	232 178 0313	Core Body	1	Radial Stretch
3	2	417902661	Wedge 1 of 8	8	Radial Stretch
4	3	424 514 6229	Core Housing	1	Radial Stretch
5	4	292 436 5662	Floor & Controller	1	Radial Stretch

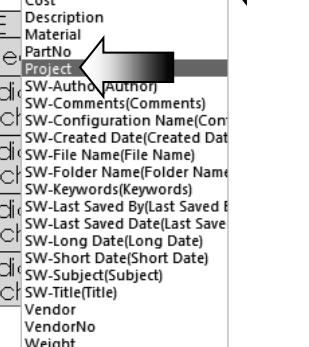

SOLIDWORKS 2019 | CSWP Advanced | Drawing Tools

- The completed Bill of Materials.

ITEM NO.	PartNo	DESCRIPTION	QTY.	Project
1	232 178 0313	Core Body	1	Radial Stretcher
2	417902661	Wedge 1 of 8	8	Radial Stretcher
3	424 514 6229	Core Housing	1	Radial Stretcher
4	292 436 5662	Floor & Controller	1	Radial Stretcher

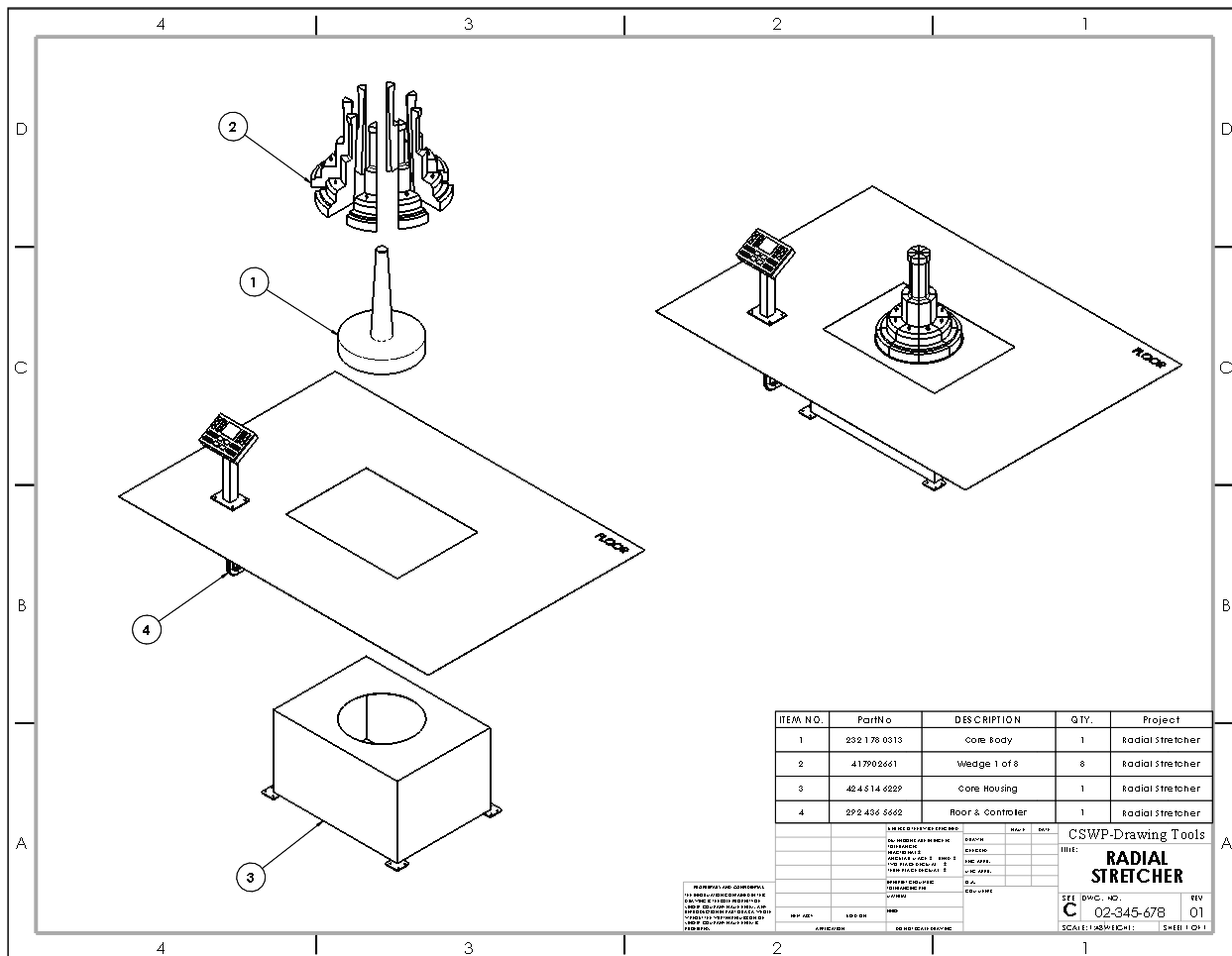

Summary:

The key features to Challenge 3 are:

- Creating an assembly drawing complete with balloons, bill of materials, and custom properties.

9. Optional:





- You can expand a BOM to view the assembly structure. For models with balloons, the assembly structure column is preceded by a per-component listing of balloons.

	A	B	C	D	E
1	ITEM NO.	PartNo	DESCRIPTION	QTY.	Project
2	1	232 178 0313	Core Body	1	Radial Stretcher
3	2	417902661	Wedge 1 of 8	8	Radial Stretcher
4	3	424 514 6229	Core Housing	1	Radial Stretcher
5	4	292 436 5662	Floor & Controller	1	Radial Stretcher

UNLESS OTHERWISE SPECIFIED:		NAME	DATE	TITLE:
DIMENSIONS ARE IN INCHES		DRAWN		
TOLERANCES:		CHECKED		
FRACTIONALS		ENG APPR.		
ANGULAR: MACH ± BEND ±		MFG APPR.		G.A.
TWO PLACE DECIMAL ±		COMMENTS:		
THREE PLACE DECIMAL ±				SIZE DWG. NO. REV
INTERPRET GEOMETRIC TOLERANCING PER:				C Draw1
MATERIAL				SCALE: 1:48 WEIGHT: SHEET 1 OF 1
PROPRIETARY AND CONFIDENTIAL		FINISH		
THE INFORMATION CONTAINED IN THIS DRAWING IS THE SOLE PROPERTY OF <INSERT COMPANY NAME HERE>. ANY REPRODUCTION IN PART OR AS A WHOLE WITHOUT THE WRITTEN PERMISSION OF <INSERT COMPANY NAME HERE> IS PROHIBITED.	NEXT ASSY	USED ON	APPLICATION	DO NOT SCALE DRAWING

- Click the side expansion arrows  at the left side of the BOM to display the assembly structure.
- The expanded BOM displays the assembly structure and indicates components that have balloons.

Hover the cursor over a balloon...

	A	B	C	D	E	
1		ITEM NO.	PartNo	DESCRIPTION	QTY.	Project
2		1	232 178 0313	Core Body	1	Radial Stretcher
3		2	417902661	Wedge 1 of 8	8	Radial Stretcher
4		3	424 514 6229	Core Housing	1	Radial Stretcher
5		4	292 436 5662	Floor & Controller	1	Radial Stretcher

UNLESS OTHERWISE SPECIFIED:		NAME	DATE	TITLE:
DIMENSIONS ARE IN INCHES		DRAWN		
TOLERANCES:		CHECKED		
FRACTIONALS		ENG APPR.		
ANGULAR: MACH ± BEND ±		MFG APPR.		G.A.
TWO PLACE DECIMAL ±		COMMENTS:		
THREE PLACE DECIMAL ±				SIZE DWG. NO. REV
INTERPRET GEOMETRIC TOLERANCING PER:				C Draw1
MATERIAL				SCALE: 1:48 WEIGHT: SHEET 1 OF 1
PROPRIETARY AND CONFIDENTIAL		FINISH		
THE INFORMATION CONTAINED IN THIS DRAWING IS THE SOLE PROPERTY OF <INSERT COMPANY NAME HERE>. ANY REPRODUCTION IN PART OR AS A WHOLE WITHOUT THE WRITTEN PERMISSION OF <INSERT COMPANY NAME HERE> IS PROHIBITED.	NEXT ASSY	USED ON	APPLICATION	DO NOT SCALE DRAWING