

**New**  
Contains three  
new chapters

# An Introduction to ANSYS® Fluent® 2020



John E. Matsson, Ph.D., P.E.



**Better Textbooks. Lower Prices.**  
[www.SDCpublications.com](http://www.SDCpublications.com)

Visit the following websites to learn more about this book:



[amazon.com](https://www.amazon.com)

[Google books](https://books.google.com)

[BARNES & NOBLE](https://www.barnesandnoble.com)

## CHAPTER 2. FLAT PLATE BOUNDARY LAYER

### A. Objectives

- Creating Geometry in ANSYS Workbench for ANSYS Fluent Flow Simulation
- Setting up ANSYS Fluent Simulation for Laminar Steady 2D Planar Flow
- Setting up Mesh
- Selecting Boundary Conditions
- Running Calculations
- Using Plots to Visualize Resulting Flow Field
- Compare with Theoretical Solution using Mathematica Code

### B. Problem Description

In this chapter, we will use ANSYS Fluent to study the two-dimensional laminar flow on a horizontal flat plate. The size of the plate is considered as being infinite in the spanwise direction and therefore the flow is 2D instead of 3D. The inlet velocity for the 1 m long plate is 5 m/s and we will be using air as the fluid for laminar simulations. We will determine the velocity profiles and plot the profiles. We will start by creating the geometry needed for the simulation.



### C. Launching ANSYS Workbench and Selecting Fluent

1. Start by launching ANSYS Workbench. Double click on Fluid Flow (Fluent) that is located under Analysis Systems in Toolbox.

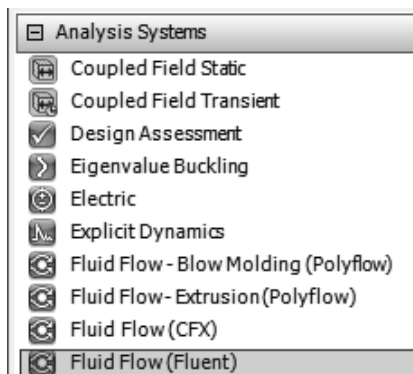

Figure 2.1 Selecting Fluid Flow

**D. Launching ANSYS DesignModeler**

2. Select Geometry under Project Schematic in ANSYS Workbench. Right-click on Geometry and select Properties. Select 2D Analysis Type under Advanced Geometry Options in Properties of Schematic A2: Geometry. Right-click on Geometry in Project Schematic and select to launch New DesignModeler Geometry. Select Units>>Millimeter as the length unit from the menu in DesignModeler.

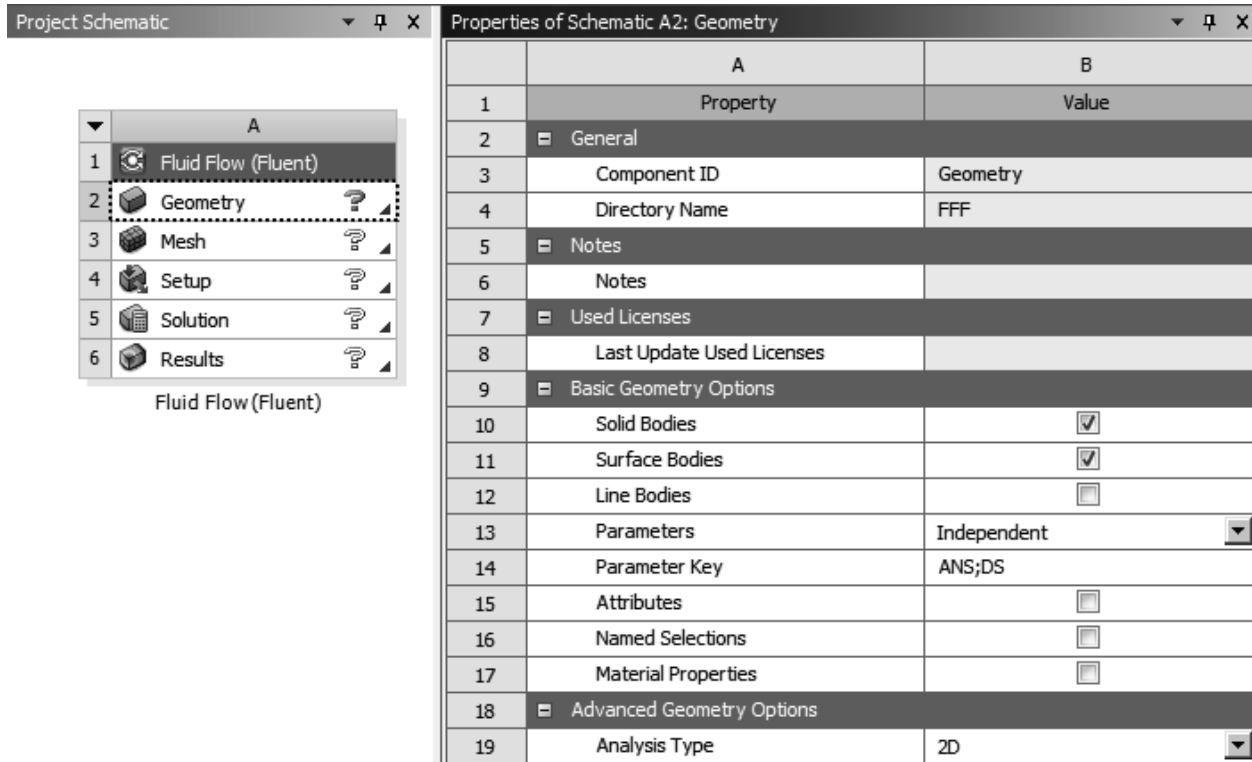

Figure 2.2a) Selecting Geometry and 2D Analysis Type

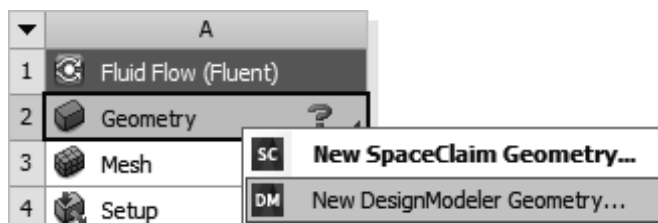

Figure 2.2b) Launching DesignModeler

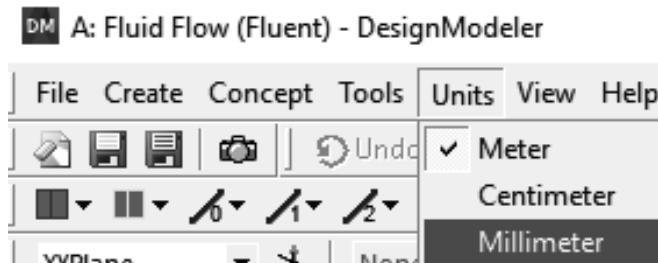

Figure 2.2c) Selecting the length unit

## CHAPTER 2. FLAT PLATE BOUNDARY LAYER

- Next, we will be creating the geometry in DesignModeler. Select XYPlane from the Tree Outline on the left-hand side in DesignModeler. Select Look at Sketch . Click on the Sketching tab in the Tree Outline and select the Line sketch tool.

Draw a horizontal line 1,000 mm long from the origin to the right. Make sure you have a *P* at the origin when you start drawing the line. Also, make sure you have an *H* along the line so that it is horizontal and a *C* at the end of the line.

Select Dimensions within the Sketching options. Click on the line and enter a length of 1,000 mm. Draw a vertical line upward 100 mm long starting at the end point of the first horizontal line. Make sure you have a *P* when starting the line and a *V* indicating a vertical line. Continue with a horizontal line 100 mm long to the left from the origin followed by another vertical line 100 mm long.

The next line will be horizontal with a length 100 mm starting at the endpoint of the former vertical line and directed to the right. Finally, close the rectangle with a 1,000 mm long horizontal line starting 100 mm above the origin and directed to the right.

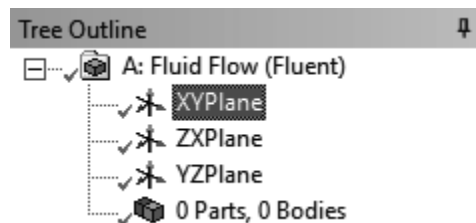

Figure 2.3a) Selection of XYPlane

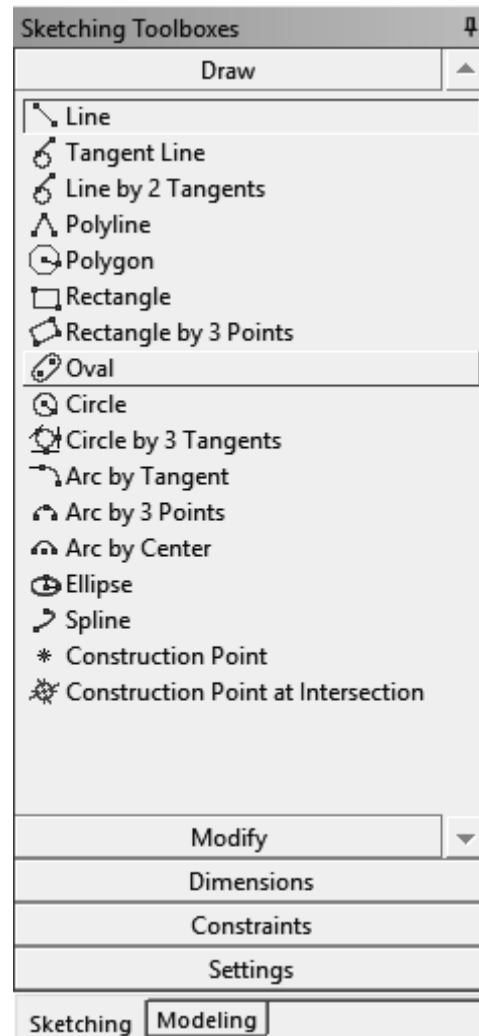

Figure 2.3b) Selection of Line tool

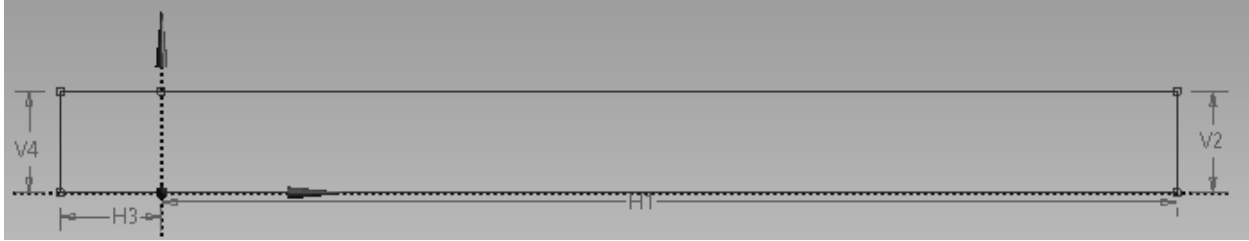

Figure 2.3c) Rectangle with dimensions

Details View	
[-] <b>Details of Sketch1</b>	
Sketch	Sketch1
Sketch Visibility	Show Sketch
Show Constraints?	No
[-] <b>Dimensions: 4</b>	
<input type="checkbox"/> H1	1000 mm
<input type="checkbox"/> H3	100 mm
<input type="checkbox"/> V2	100 mm
<input type="checkbox"/> V4	100 mm

Figure 2.3d) Dimensions in Details View

- Click on the Modeling tab under Sketching Toolboxes. Select Concept>>Surfaces from Sketches in the menu. Control select the six edges of the rectangle as Base Objects and select Apply in Details View. Click on Generate in the toolbar . The rectangle turns gray. Right click in the graphics window and select Zoom to Fit and close DesignModeler.

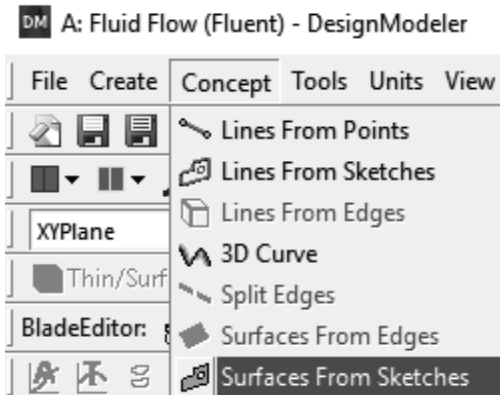

Figure 2.4a) Selecting Surfaces from Sketches

Details View	
[-] <b>Details of SurfaceSk1</b>	
Surface From Sketches	SurfaceSk1
Base Objects	Apply Cancel
Operation	Add Material
Orient With Plane Normal?	Yes
Thickness (>=0)	0 mm

Figure 2.4b) Applying Base Objects

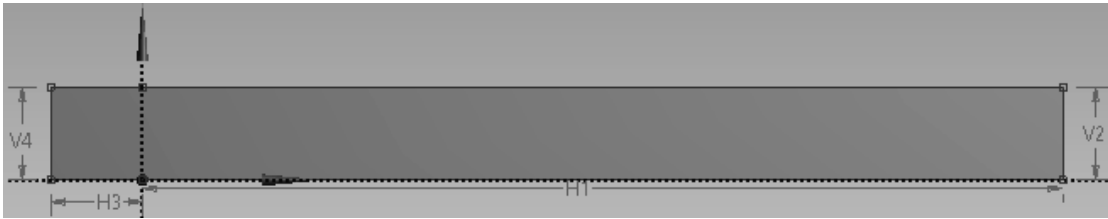

Figure 2.4c) Completed rectangle in DesignModeler

### E. Launching ANSYS Meshing

5. We are now going to double click on Mesh under Project Schematic in ANSYS Workbench to open the Meshing window. Select Mesh in the Outline of the Meshing window. Right click and select Generate Mesh. A coarse mesh is created. Select Unit Systems>>Metric (mm, kg, N ...)

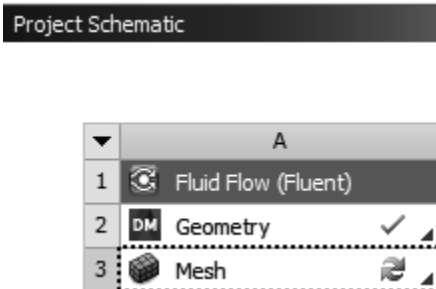

Figure 2.5a) Launching mesh

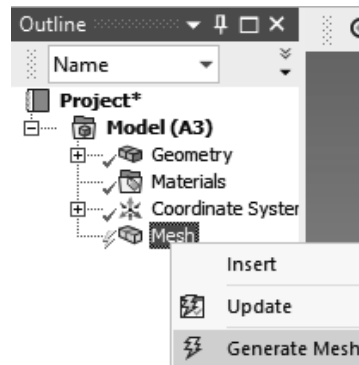

Figure 2.5b) Generating mesh



Figure 2.5c) Coarse mesh

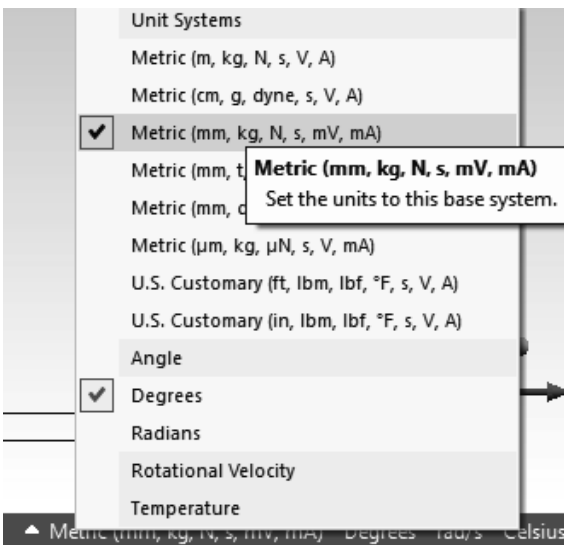

Figure 2.5d) Selection of units in graphics window

## CHAPTER 2. FLAT PLATE BOUNDARY LAYER

Select Mesh>> Controls>>Face Meshing from the menu. Click on the yellow region next to Geometry under Scope in Details of Face Meshing. Select the rectangle in the graphics window. Click on the Apply button for Geometry in Details of “Face Meshing”. Select Mesh>>

Controls>>Sizing from the menu and select Edge  above the graphics window.

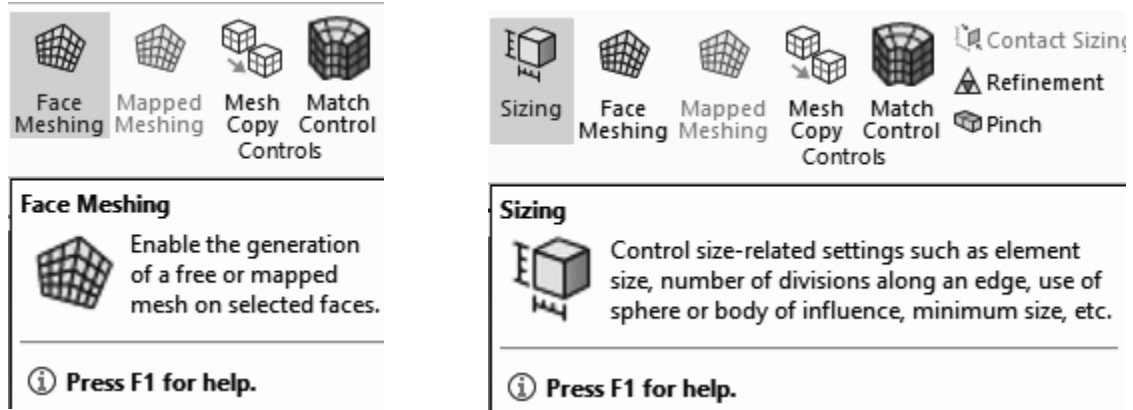

Figure 2.5e) Selection of face meshing      Figure 2.5f) Sizing

Select the upper longer horizontal edge of the rectangle, control select the lower horizontal edges and the vertical edges for a total of 5 edges. Click on Apply for the Geometry in “Details of Edge Sizing”. Under Definition in “Details of Edge Sizing”, select Element Size as Type, 1.0 mm for Element Size, and Hard as Behavior. Select the second Bias Type - - - - - and enter 12.0 as the Bias Factor.

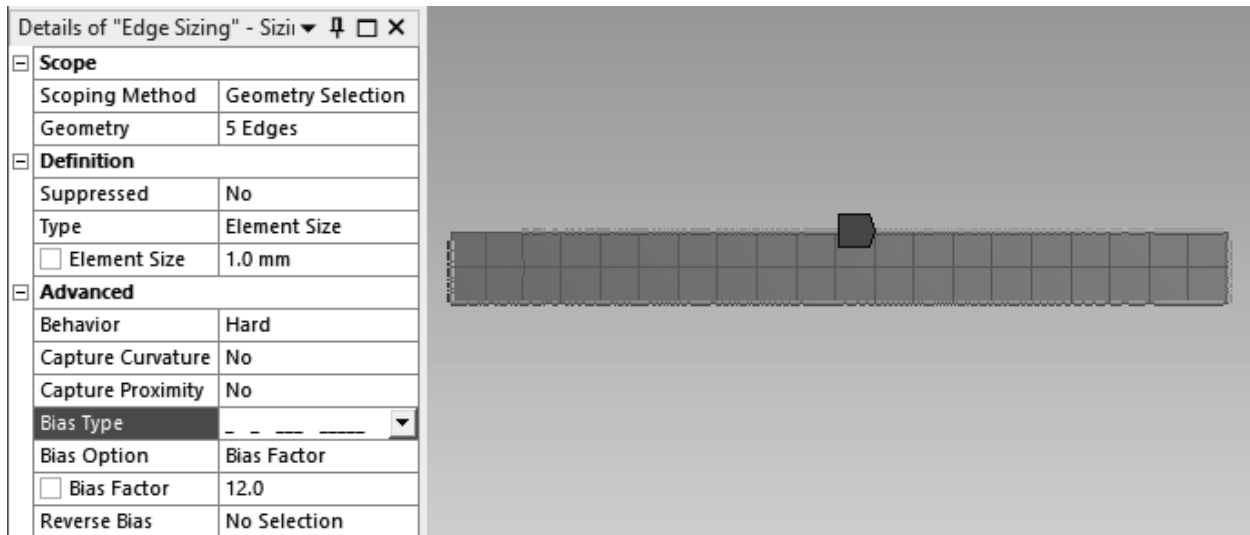

Figure 2.5g) Details of edge sizing for three of the horizontal edges and the vertical edges

Repeat the selection of Mesh>>Controls>>Sizing from the menu once again but this time select the upper horizontal edge to the left of the origin. Enter the same Element Size, Behavior, and Bias Factor but the first Bias Type — — - - . Click on Home>>Generate Mesh in the menu and select Mesh in the Outline. The finished mesh is shown in the graphics window.



## CHAPTER 2. FLAT PLATE BOUNDARY LAYER

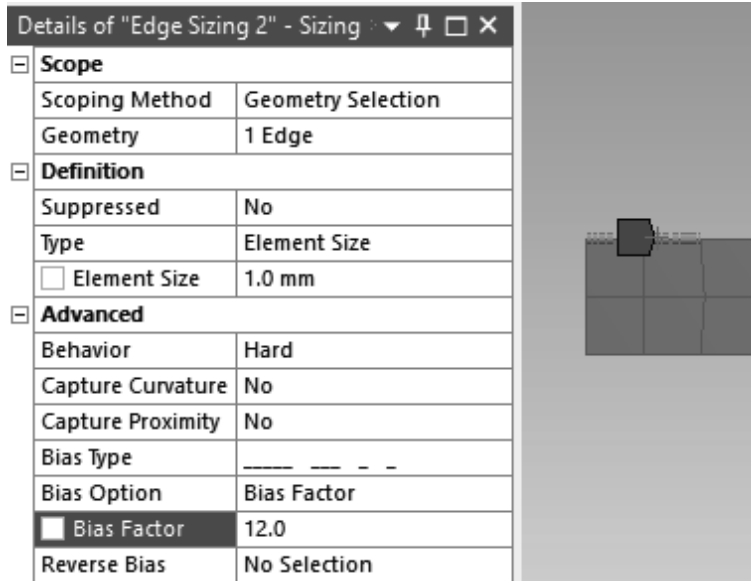

Figure 2.5h) Details of edge sizing for the remaining horizontal edge

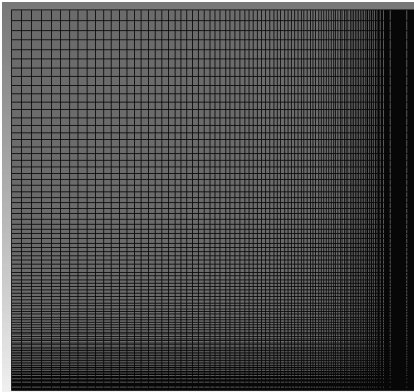

Figure 2.5i) Details of finished mesh

**Why did we create a biased mesh?** The reason for using a biased mesh is that we need a finer mesh close to the wall where we have velocity gradients in the flow. We also included a finer mesh where the boundary layer starts to develop on the flat plate.

We are now going to rename the edges for the rectangle. Select the left edge of the rectangle, right click and select Create Named Selection. Enter *inlet* as the name and click on the OK button.

Repeat this step for the right vertical edge of the rectangle and enter the name *outlet*. Create a named selection for the lower longer horizontal right edge and call it *wall*. Finally, control-select the remaining three horizontal edges and name them *ideal wall*. An ideal wall is an adiabatic and frictionless wall.



Figure 2.5j) Named selections

Select File>>Export...>>Mesh>>FLUENT Input File>>Export from the menu. Select Save as type: FLUENT Input Files (\*.msh). Enter “boundary-layer-mesh” as file name and click on the Save button. Select File>>Save Project from the menu. Name the project “Flat Plate Boundary Layer”. Close the ANSYS Meshing window. Right click on Mesh in Project Schematic and select Update.

## F. Launching ANSYS Fluent

- We are now going to double click on Setup under Project Schematic in ANSYS Workbench to open Fluent. Launch the Dimension 2D and Double Precision solver of Fluent. Check the Double Precision. Set the number of Solver Processes equal to the number of computer cores. To check the number of physical cores, press the Ctrl + Shift + Esc keys simultaneously to open the Task Manager. Go to the Performance tab and select CPU from the left column. You'll see the number of physical cores on the bottom-right side. Click on Show More Options. Write down the location of the working directory as you will use this information later. Click on the Start button to launch ANSYS Fluent.

**Why do we use double precision?** Double precision will give more accurate calculations than single precision.

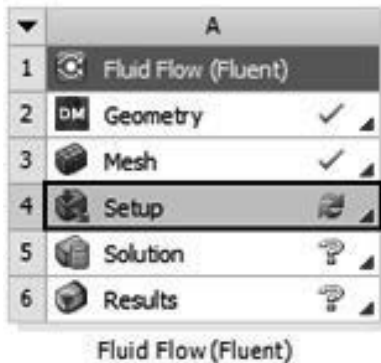

Figure 2.6a) Launching Setup

## CHAPTER 2. FLAT PLATE BOUNDARY LAYER

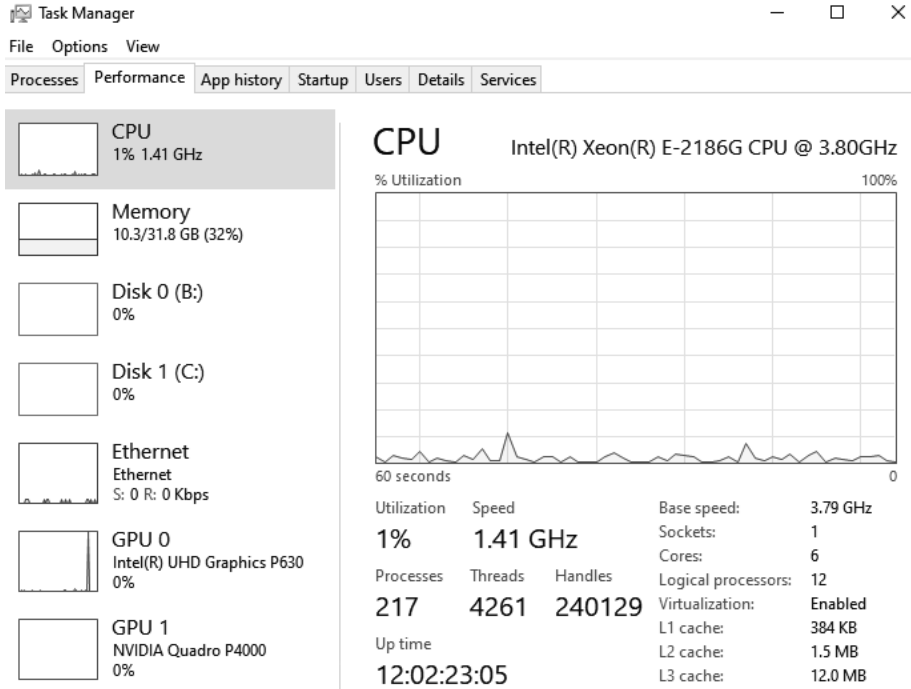

Figure 2.6b) Taskmanager

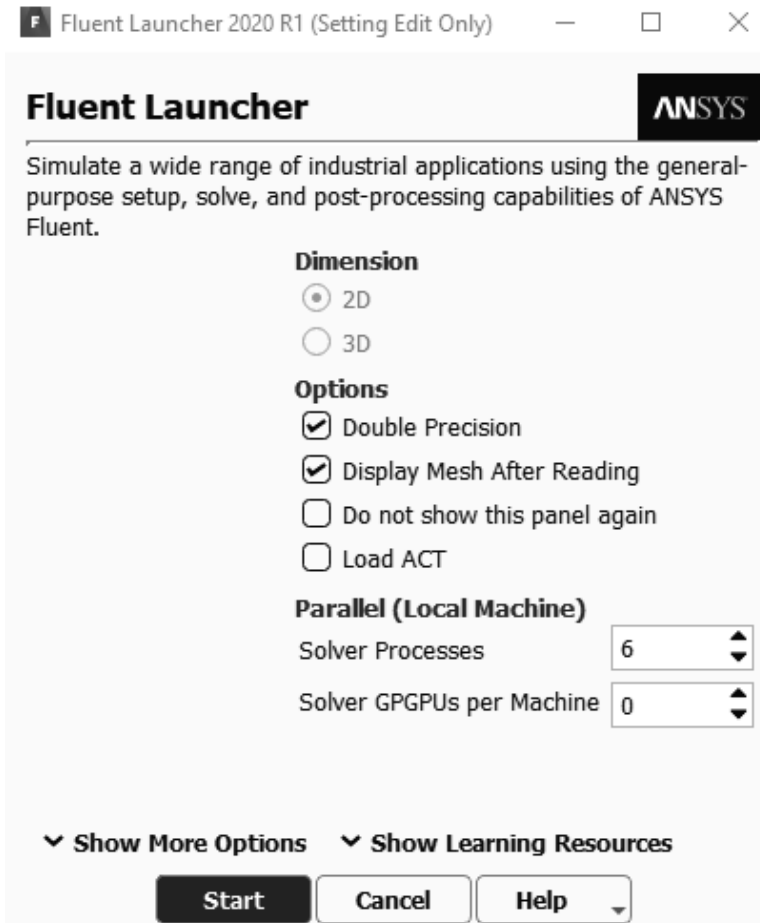
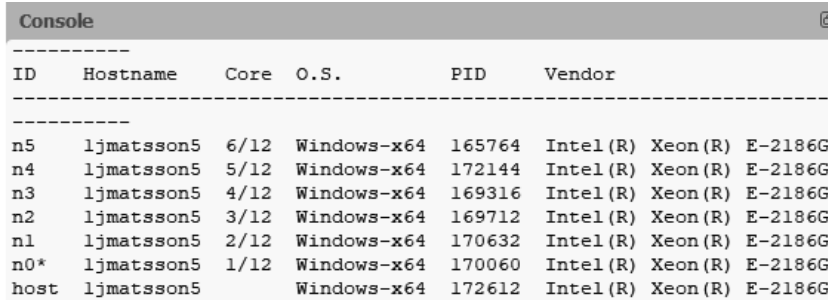

Figure 2.6c) Fluent Launcher

## CHAPTER 2. FLAT PLATE BOUNDARY LAYER



ID	Hostname	Core	O.S.	PID	Vendor
n5	ljmatsson5	6/12	Windows-x64	165764	Intel (R) Xeon (R) E-2186G
n4	ljmatsson5	5/12	Windows-x64	172144	Intel (R) Xeon (R) E-2186G
n3	ljmatsson5	4/12	Windows-x64	169316	Intel (R) Xeon (R) E-2186G
n2	ljmatsson5	3/12	Windows-x64	169712	Intel (R) Xeon (R) E-2186G
n1	ljmatsson5	2/12	Windows-x64	170632	Intel (R) Xeon (R) E-2186G
n0*	ljmatsson5	1/12	Windows-x64	170060	Intel (R) Xeon (R) E-2186G
host	ljmatsson5		Windows-x64	172612	Intel (R) Xeon (R) E-2186G

Figure 2.6d) Example of console printout for four cores

7. Check the scale of the mesh by selecting the Scale button under Mesh in General on the Task Page. Make sure that the Domain Extent is correct and close the Scale Mesh window.

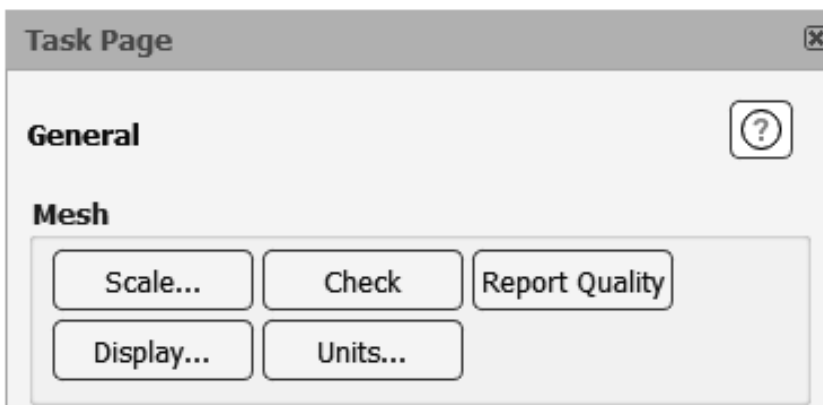

Figure 2.7a) Scale Check

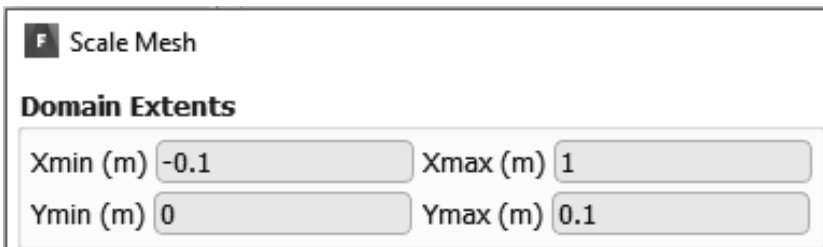

Figure 2.7b) Scale Mesh

8. Double click on Models and Viscous (SST k-omega). Select Laminar as Viscous Model. Click Ok to close the window. Double click on Boundary Conditions under Setup in the Outline View. Double click on *inlet* under Zone on the Task Page. Choose Components as Velocity Specification Method and set the X-Velocity (m/s) to 5. Click on the OK button to close the window. Double click on *ideal\_wall* under Zones. Check Specified Shear as Shear Condition and keep zero values for specified shear stress since an ideal wall is frictionless. Click OK to close the window.

**Why did we select Laminar as Viscous Model?** For the chosen free stream velocity 5 m/s the Reynolds number is less than 500,000 along the plate and the flow is therefore laminar. Turbulent flow along a flat plate occurs at Reynolds numbers above 500,000.

## CHAPTER 2. FLAT PLATE BOUNDARY LAYER

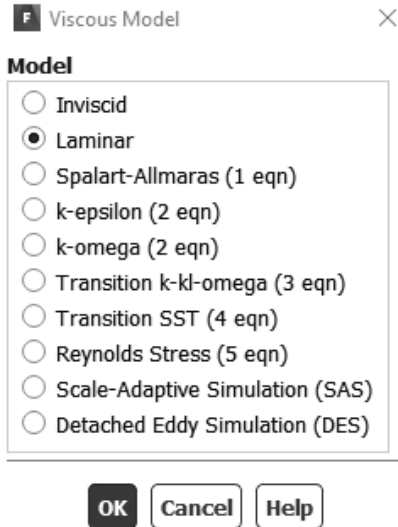

Figure 2.8a) Viscous model

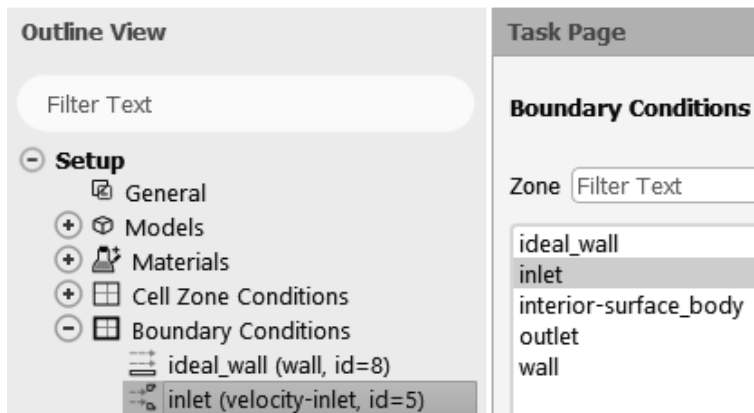

Figure 2.8b) Boundary Conditions for inlet

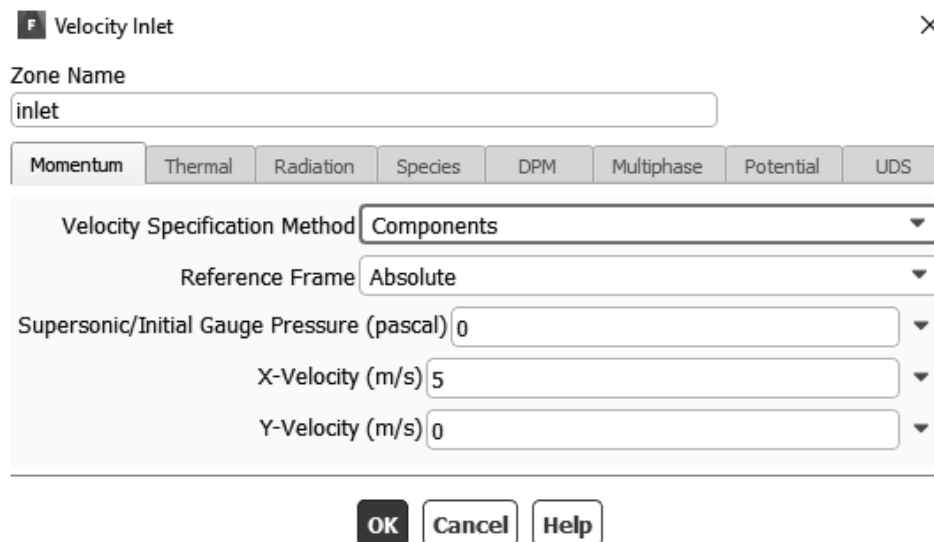

Figure 2.8c) Inlet velocity

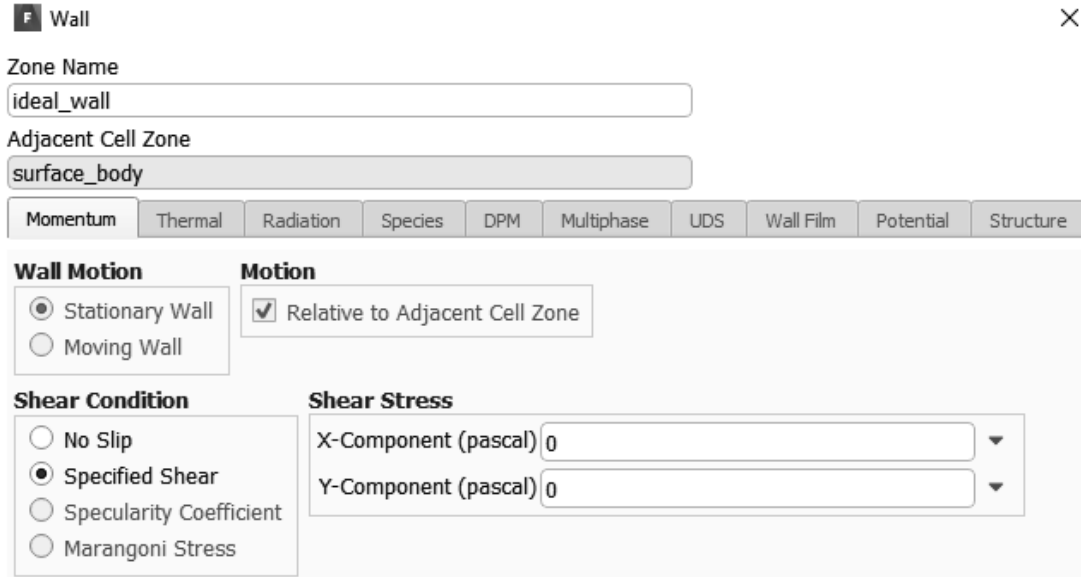

Figure 2.8d) Specified shear for ideal wall

9. Double click on Methods under Solution in the Outline View. Select *Standard* for Pressure and *First Order Upwind* for Momentum. Double click on Reference Values under Setup in the Outline View. Select *Compute from inlet* on the Task Page.

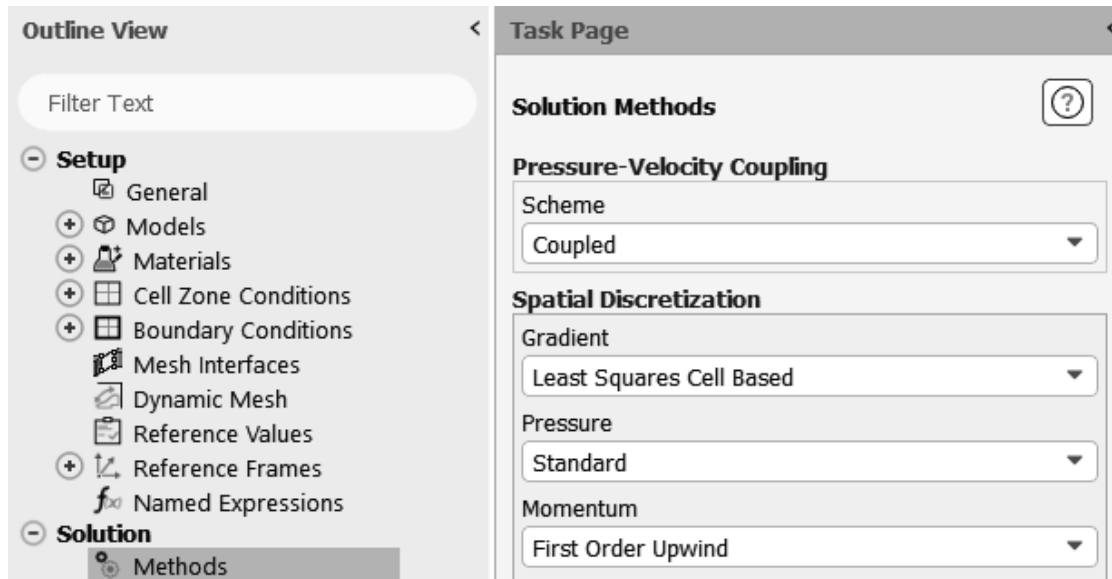

Figure 2.9a) Solution Methods Task Page

**Why do we use First Order Upwind method for Spatial Discretization of Momentum?** The First Order Upwind method is generally less accurate but converges better than the Second Order Upwind method. It is common practice to start with the First Order Upwind method at the beginning of calculations and continue with the Second Order Upwind method.

## CHAPTER 2. FLAT PLATE BOUNDARY LAYER

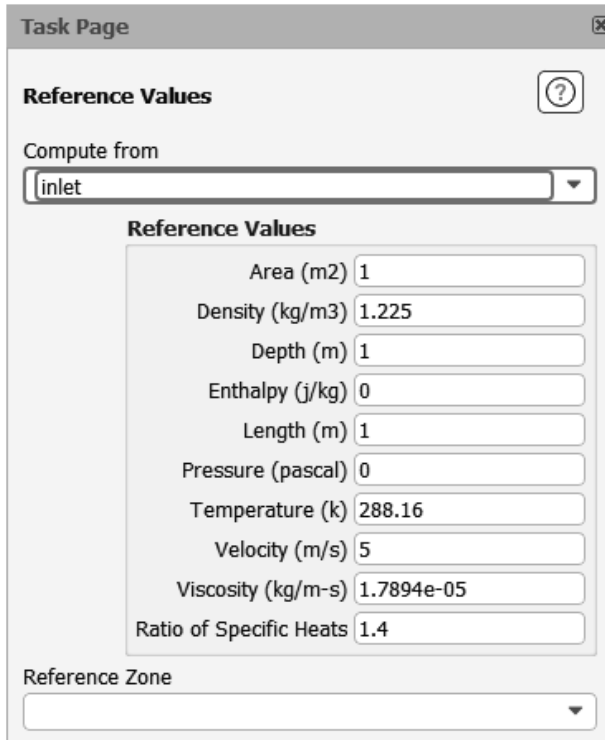

Figure 2.9b) Reference values

10. Double click on Initialization under Solution in the Outline View, select *Standard Initialization*, select *Compute from inlet*, and click on the *Initialize* button.

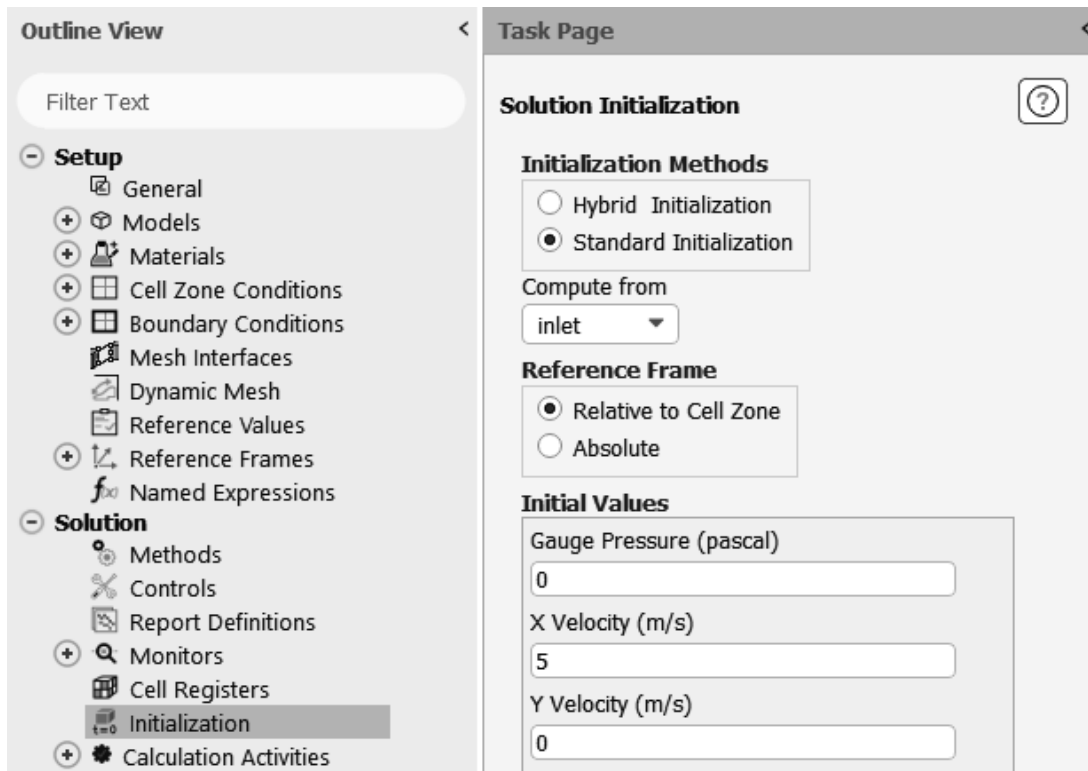

Figure 2.10 Solution Initialization

## CHAPTER 2. FLAT PLATE BOUNDARY LAYER

11. Double click on Monitors under Solution in the Outline View. Double click on Residual under Monitors and enter  $1e-9$  as *Absolute Criteria* for all Residuals. Click on the OK button to close the window.

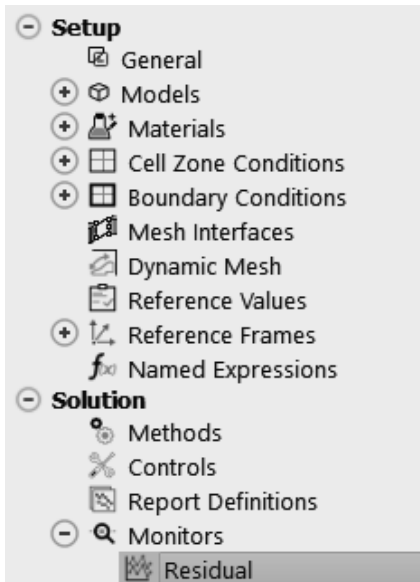

Figure 2.11a) Residual monitors

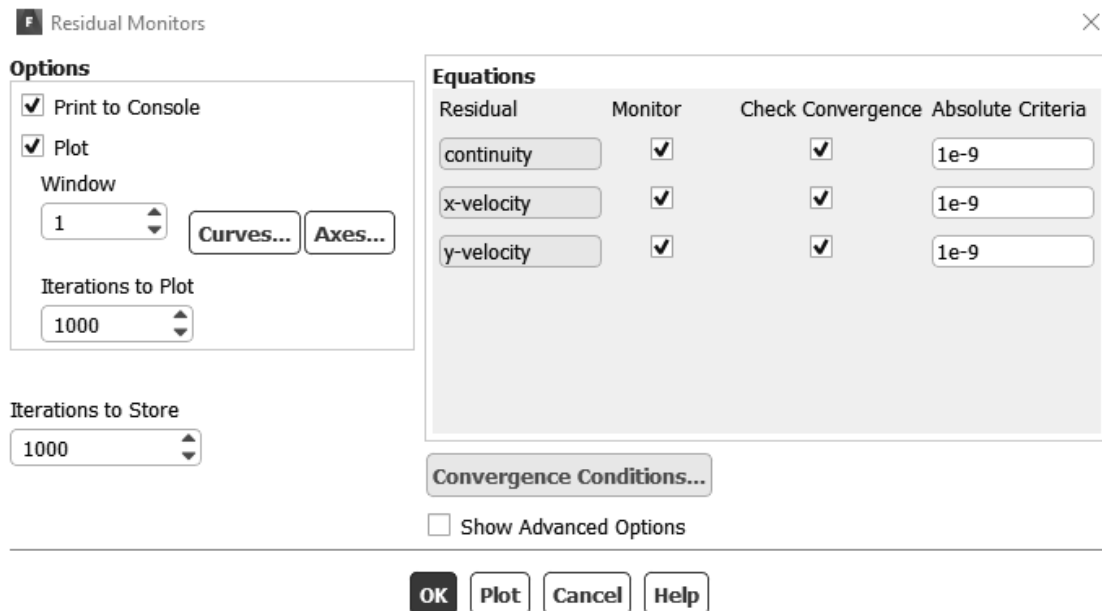

Figure 2.11b) Residual Monitors settings

**Why did we set the Absolute Criteria to  $1e-9$ ?** Generally, the lower the absolute criteria, the longer time the calculation will take and give a more exact solution. We see in Figure 2.12b) that the  $x$ -velocity and  $y$ -velocity equations have lower residuals than the continuity equation. The slopes of the residual curves for all three equations are about the same with a sharp downward trend.



## CHAPTER 2. FLAT PLATE BOUNDARY LAYER

12. Double click on Run Calculation under Solution and enter 5000 for *Number of Iterations*. Click on the *Calculate* button.

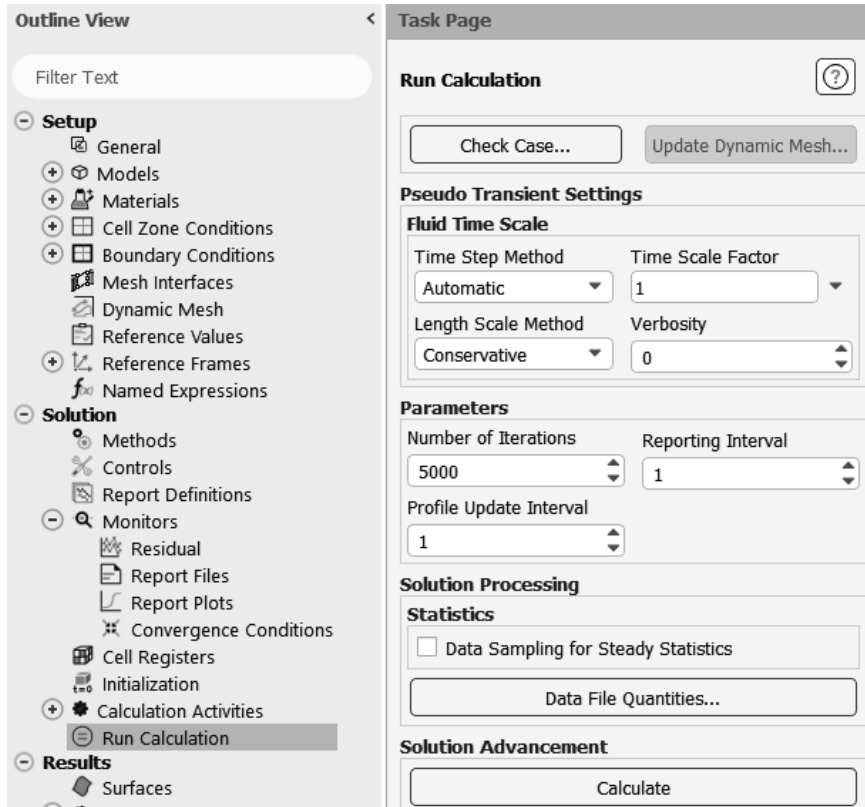

Figure 2.12a) Running the calculations

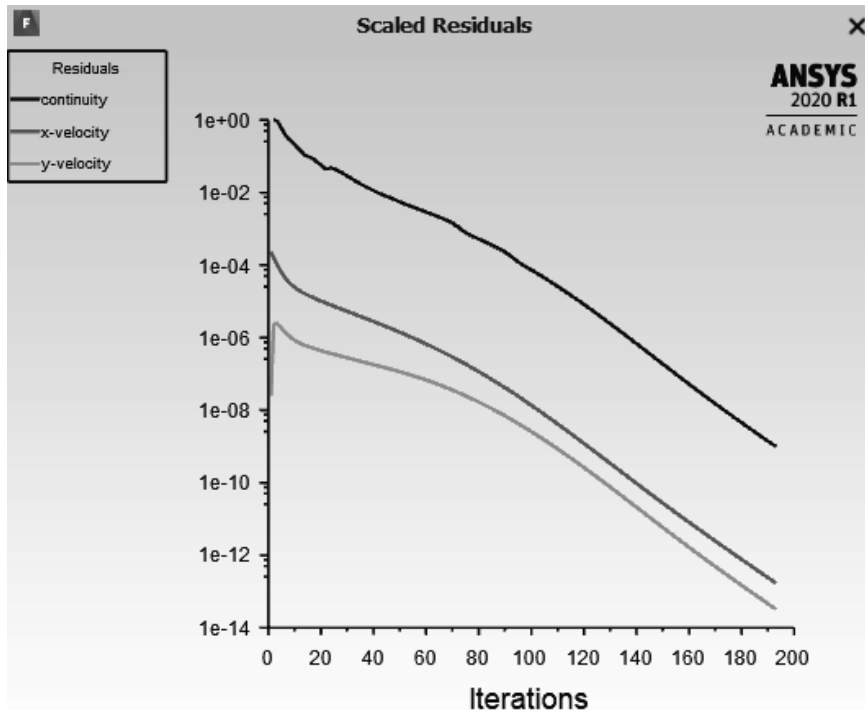

Figure 2.12b) Scaled Residuals

**G. Post-Processing**

13. Select the Results tab in the menu and select Create>>Line/Rake under Surface. Enter 0.2 for  $x_0$  (m), 0.2 for  $x_1$  (m), 0 for  $y_0$  (m), and 0.02 m for  $y_1$  (m). Enter  $x=0.2m$  for the New Surface Name and click on Create. Repeat this step three more times and create vertical lines at  $x = 0.4m$  (length 0.04 m),  $x=0.6m$  (length 0.06 m), and  $x=0.8m$  (length 0.08 m). Close the window.

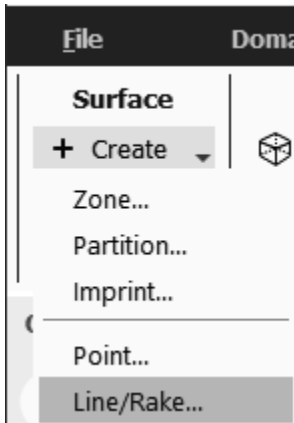

Figure 2.13a) Selecting Line/Rake from the Post-processing menu

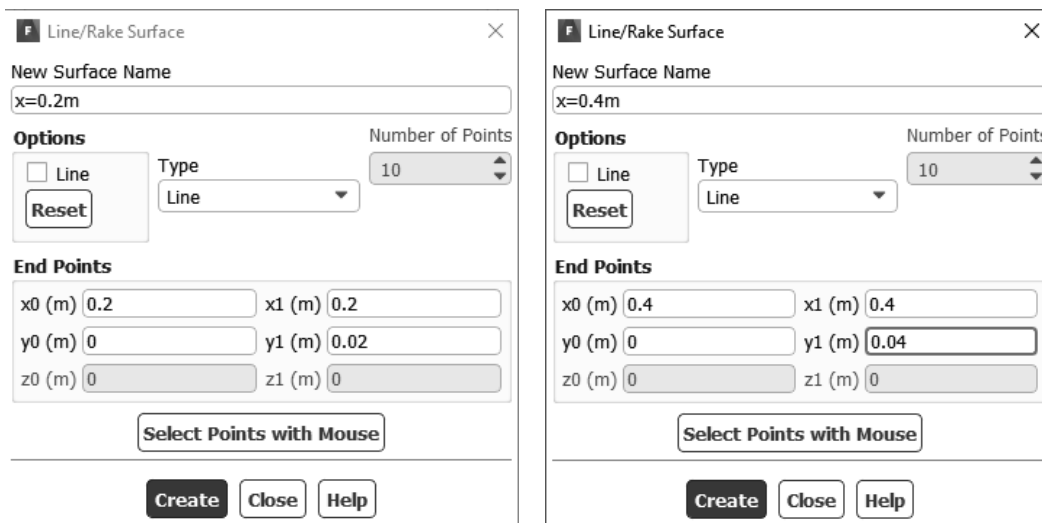

Figure 2.13b) Line/Rake Surfaces at  $x=0.2$  m and  $x=0.4m$

14. Double click on Plots and XY Plot under Results in the Outline View. Uncheck Position on X Axis under Options and check Position on Y Axis. Set Plot Direction for X to 0 and 1 for Y. Select Velocity... and X Velocity as X Axis Function. Select the four surfaces  $x=0.2m$ ,  $x=0.4m$ ,  $x=0.6m$ , and  $x=0.8m$ .

## CHAPTER 2. FLAT PLATE BOUNDARY LAYER

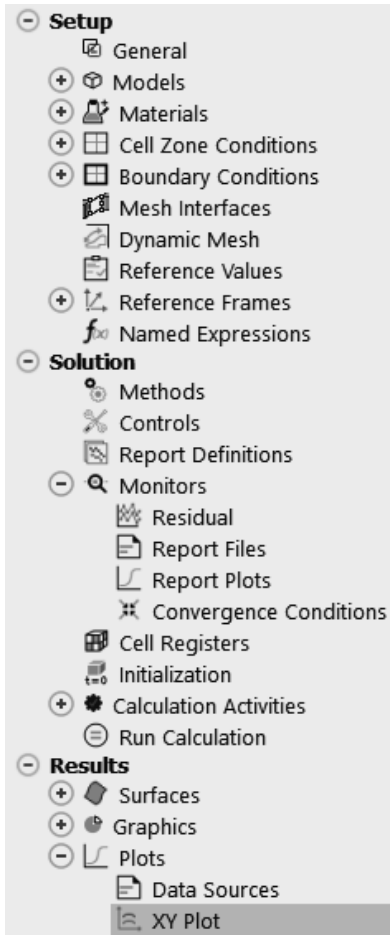

Figure 2.14a) XY Plot setup

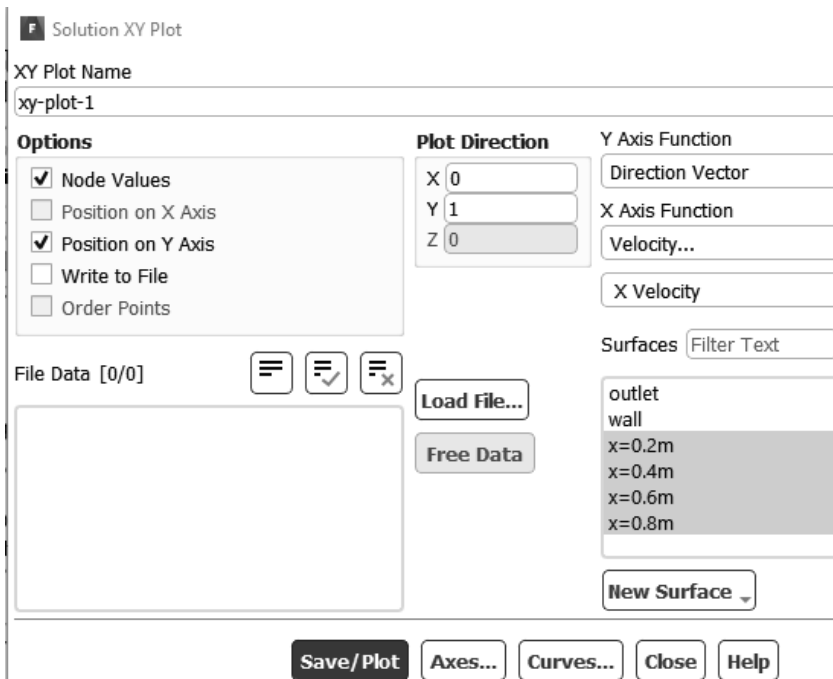

Figure 2.14b) Settings for Solution XY Plot

## CHAPTER 2. FLAT PLATE BOUNDARY LAYER

- Click on the *Axes* button in the Solution XY Plot window. Select the X Axis, uncheck Auto Range under Options, enter 6 for Maximum Range, select general Type under Number Format and set Precision to 0. Click on the Apply button. Select the Y Axis, uncheck the Auto Range, enter 0.01 for Maximum Range, select general Type under Number Format, and click on the Apply button. Close the Axes window.

The screenshot shows the 'Axes - Solution XY Plot' dialog box with the X-axis selected. The 'Axis' section has the X-axis radio button selected. The 'Number Format' section has 'Type' set to 'general' and 'Precision' set to 0. The 'Range' section has 'Maximum' set to 6. The 'Options' section has 'Auto Range' unchecked. The 'Major Rules' section has 'Color' set to 'foreground' and 'Weight' set to 1. The 'Minor Rules' section has 'Color' set to 'dark gray' and 'Weight' set to 1. The 'Apply' button is highlighted.

Figure 2.15a) Settings for X Axes

The screenshot shows the 'Axes - Solution XY Plot' dialog box with the Y-axis selected. The 'Axis' section has the Y-axis radio button selected. The 'Number Format' section has 'Type' set to 'general' and 'Precision' set to 2. The 'Range' section has 'Maximum' set to 0.01. The 'Options' section has 'Auto Range' unchecked. The 'Major Rules' section has 'Color' set to 'foreground' and 'Weight' set to 1. The 'Minor Rules' section has 'Color' set to 'dark gray' and 'Weight' set to 1. The 'Apply' button is highlighted.

Figure 2.15b) Settings for Y Axes

## CHAPTER 2. FLAT PLATE BOUNDARY LAYER

- Click on the Curves... button in the Solution XY Plot window. Select the first pattern under Line Style for Curve # 0. Select no Symbol for Marker Style and click on the Apply button.

Next select Curve # 1, select the next available Pattern for Line Style, no Symbol for Marker Style, and click on the Apply button. Continue this pattern of selection with the next two curves # 2 and # 3. Close the Curves – Solution XY Plot window. Click on the Save/Plot button in the Solution XY Plot window and close this window.

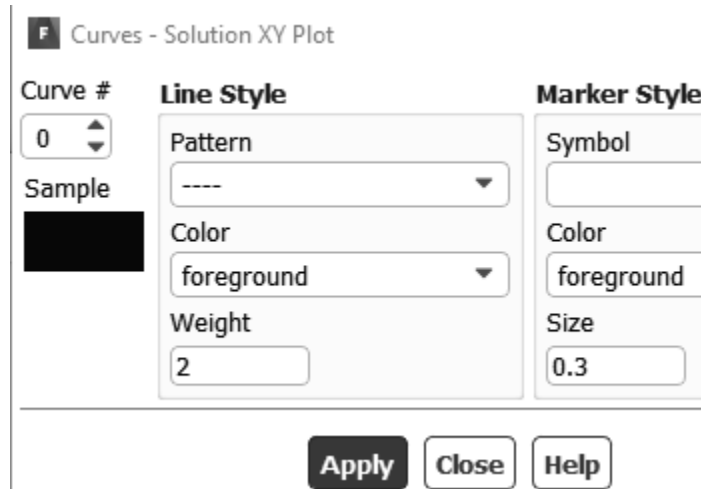

Figure 2.16a) Settings for curve # 0

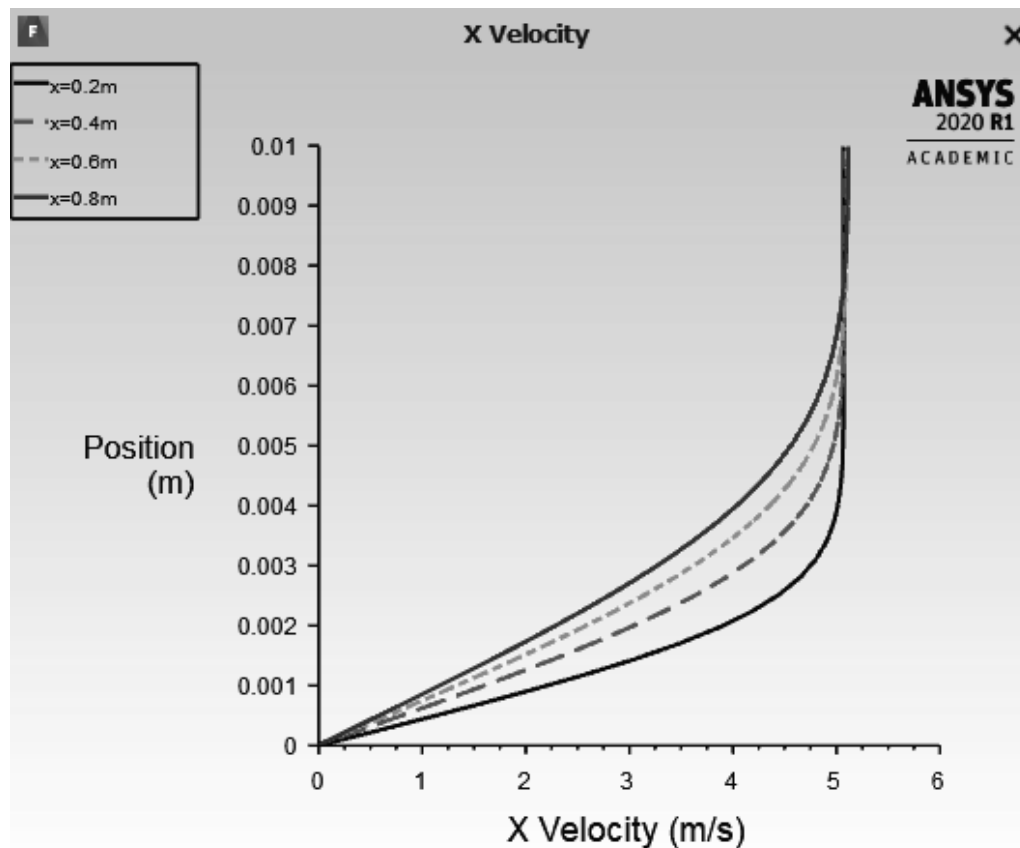

Figure 2.16b) Velocity profiles for a laminar boundary layer on a flat plate

## CHAPTER 2. FLAT PLATE BOUNDARY LAYER

Select the *User Defined* tab in the menu and *Custom*. Select a specific *Operand Field Functions* from the drop-down menu by selecting *Mesh...* and *Y-Coordinate*. Click on *Select* and enter the definition as shown in Figure 2.16e). You need to select *Mesh...* and *X-Coordinate* to complete the definition of the field function. Enter *eta* as *New Function Name*, click on *Define* and close the window.

Repeat this step to create another custom field function. This time, we select *Velocity...* and *X Velocity* as *Field Functions* and click on *Select*. Complete the *Definition* as shown in Figure 2.16f) and enter *u-divided-by-freestream-velocity* as *New Function Name*, click on *Define* and close the window.



Figure 2.16c) Custom Field Functions

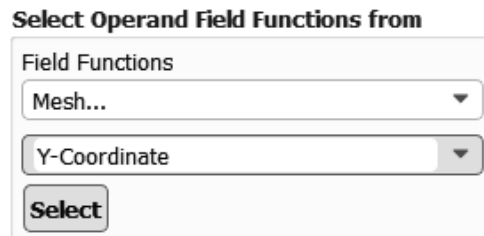

Figure 2.16d) Operand Field Function

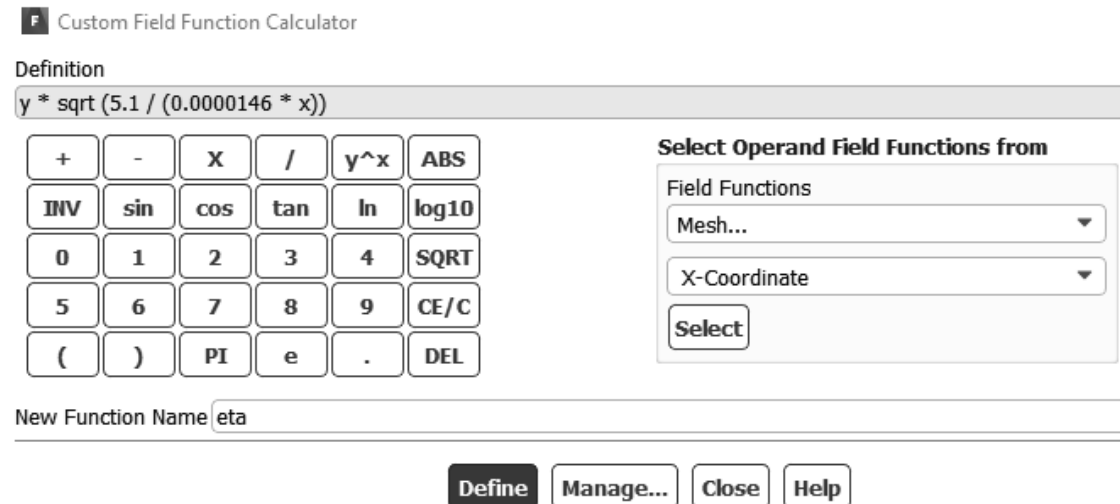

Figure 2.16e) Custom field function for self-similar coordinate

**Why did we create a self-similar coordinate?** It turns out that by using a self-similar coordinate, the velocity profiles at different streamwise positions will collapse on one self-similar velocity profile that is independent of the streamwise location.

## CHAPTER 2. FLAT PLATE BOUNDARY LAYER

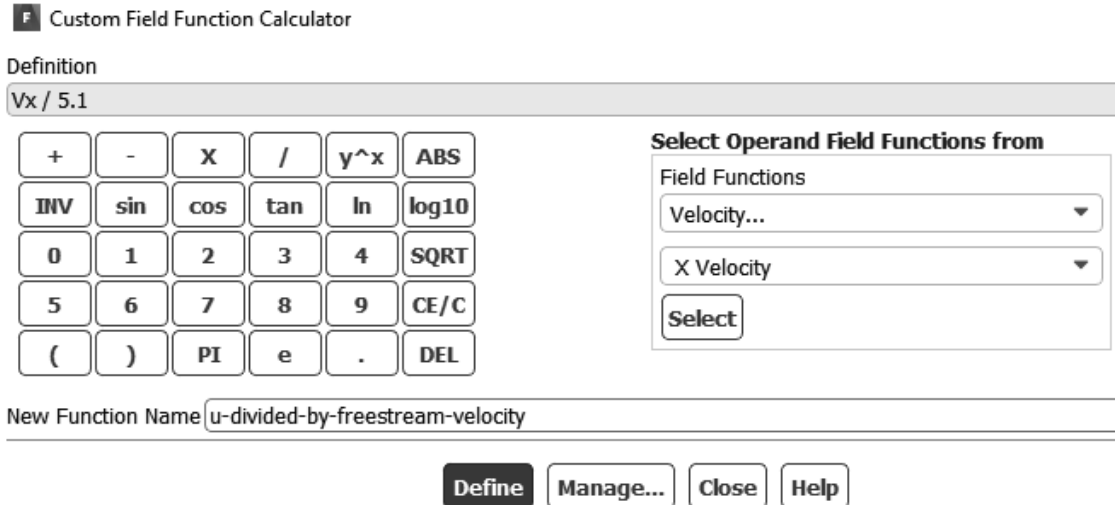

Figure 2.16f) Custom field function for non-dimensional velocity

17. Double click on Plots and XY Plot under Results in the Outline View. Set X to 0 and Y to 1 as Plot Direction. Uncheck *Position on X Axis* and *Position on Y Axis* under *Options*. Select *Custom Field Functions* and *eta* for *Y Axis Function* and select *Custom Field Functions* and *u-divided-by-freestream-velocity* for *X Axis Function*.

Place the file “*blasius.dat*” in your working directory. This file can be downloaded from [sdcpublications.com](http://sdcpublications.com). See Figure 2.19 for the Mathematica code that can be used to generate the theoretical Blasius velocity profile for laminar boundary layer flow over a flat plate. As an example, in this case the working directory is *C:\Users\jmatsson*. Click on *Load File*. Select Files of type: All Files (\*) and select the file “*blasius.dat*” from your working directory. Select the four surfaces  $x=0.2m$ ,  $x=0.4m$ ,  $x=0.6m$ ,  $x=0.8m$  and the loaded file *Theory*.



Figure 2.17a) Solution XY Plot for self-similar velocity profiles

## CHAPTER 2. FLAT PLATE BOUNDARY LAYER

Click on the Axes button. Select *Y Axis* in Axes-Solution XY Plot window and uncheck *Auto Range*. Set the *Minimum Range* to 0 and *Maximum Range* to 10. Set the Type to float and Precision to 0 under Number Format. Enter the Label as *eta* and click on *Apply*.

Select *X Axis* in Axes-Solution XY Plot window and enter the Label to *u/U*. Check the box for *Auto Range*. Set the Type to float and Precision to 1 under Number Format. Click on *Apply* and close the window.

Click on the Curves... button in the Solution XY Plot window. Select the first pattern under Line Style for Curve # 0. Select no Symbol for Marker Style and click on the *Apply* button.

Next select Curve # 1, select the next available Pattern for Line Style, no Symbol for Marker Style, and click on the *Apply* button. Continue this pattern of selection with the next two curves # 2 and # 3. Close the Curves – Solution XY Plot window. Click on the *Save/Plot* button in the Solution XY Plot window and close this window.

The image shows a dialog box titled "Axes - Solution XY Plot". It is divided into several sections:

- Axis:** Radio buttons for "X" and "Y". The "Y" radio button is selected.
- Label:** A text input field containing "eta".
- Options:** Four checkboxes: "Log", "Auto Range", "Major Rules", and "Minor Rules". All are currently unchecked.
- Number Format:** A dropdown menu set to "float" and a spin box set to "0".
- Range:** Two input fields: "Minimum" set to "0" and "Maximum" set to "10".
- Major Rules:** "Color" set to "foreground" and "Weight" set to "1".
- Minor Rules:** "Color" set to "dark gray" and "Weight" set to "1".

At the bottom of the dialog are three buttons: "Apply", "Close", and "Help".

Figure 2.17b) Axes – Solution XY Plot window settings for Y Axis



## CHAPTER 2. FLAT PLATE BOUNDARY LAYER

**F** Axes - Solution XY Plot

<b>Axis</b> <input checked="" type="radio"/> X <input type="radio"/> Y	<b>Number Format</b> Type: float Precision: 1	<b>Major Rules</b> Color: foreground Weight: 1
<b>Label</b> u/U	<b>Options</b> <input type="checkbox"/> Log <input checked="" type="checkbox"/> Auto Range <input type="checkbox"/> Major Rules <input type="checkbox"/> Minor Rules	<b>Range</b> Minimum: 0 Maximum: 0
		<b>Minor Rules</b> Color: dark gray Weight: 1

**Apply** **Close** **Help**

Figure 2.17c) Axes – Solution XY Plot window settings for X Axis

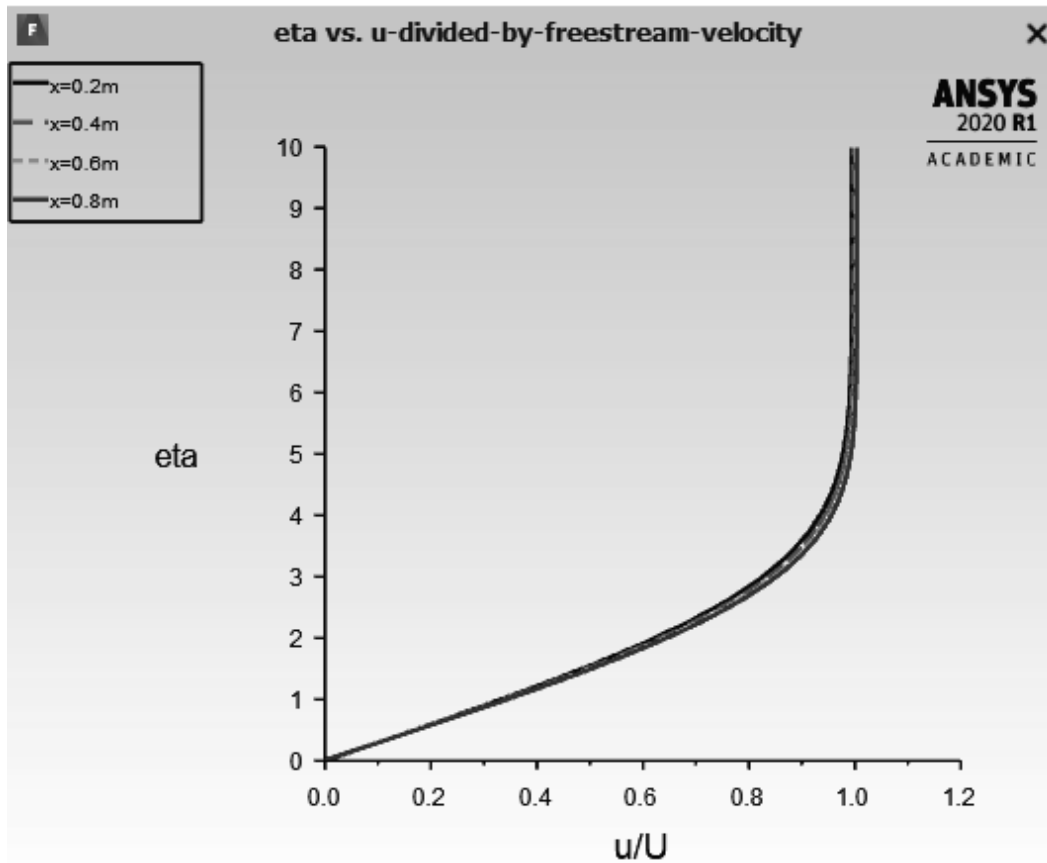

Figure 2.17d) Self-similar velocity profiles for a laminar boundary layer on a flat plate

## CHAPTER 2. FLAT PLATE BOUNDARY LAYER

Select the User Defined tab in the menu and Custom. Select a specific Operand Field Functions from the drop-down menu by selecting Mesh... and X-Coordinate. Click on Select and enter the definition as shown in Figure 2.17e). Enter *re-x* as New Function Name, click on Define and Close the window.

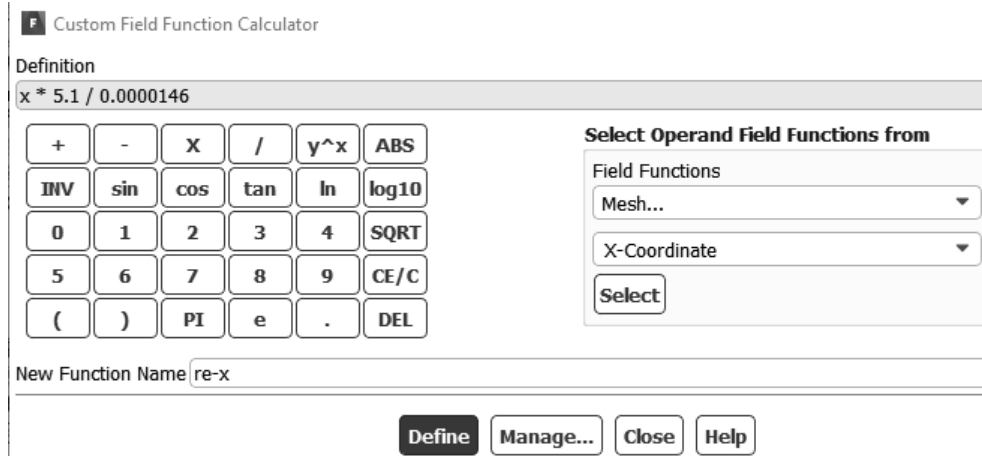

Figure 2.17e) Custom field function for Reynolds number

18. Double click on Plots and XY Plot under Results in the Outline View. Set X to 0 and Y to 1 under Plot Direction. Uncheck Position on X Axis and Position on Y Axis under Options. Select *Wall Fluxes* and *Skin Friction Coefficient* for Y Axis Function and select Custom Field Functions and *re-x* for X Axis Function.

Place the file “*Theoretical Skin Friction Coefficient*” in your working directory. Click on Load File. Select Files of type: All Files (\*) and select the file “*Theoretical Skin Friction Coefficient*”. Select *wall* under Surfaces and the loaded file Skin Friction under File Data. Click on the Axes button.

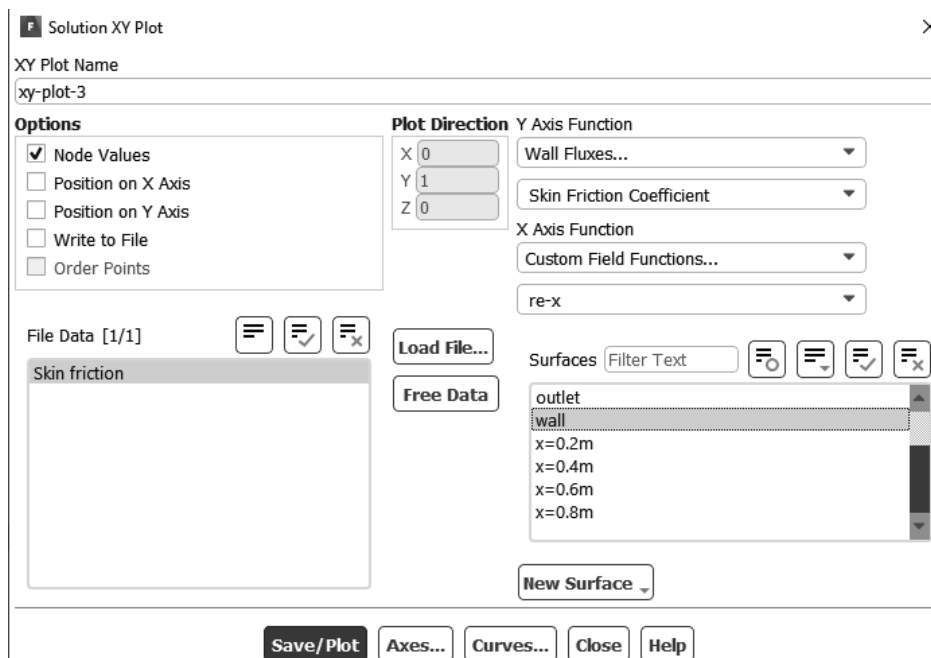

Figure 2.18a) Solution XY Plot for skin friction coefficient

## CHAPTER 2. FLAT PLATE BOUNDARY LAYER

Check the X Axis, check the box for Log under Options, enter Re-x as Label, uncheck Auto Range under Options, set Minimum to 100 and Maximum to 1000000. Set Type to float and Precision to 0 under Number Format and click on Apply.

Check the Y Axis, check the box for Log under Options, enter Cf-x as Label, uncheck Auto Range, set Minimum to 0.001 and Maximum to 0.1, set Type to float, Precision to 3 and click on Apply. Close the window. Click on Save/Plot in the Solution XY Plot window.

Click on the Curves... button in the Solution XY Plot window. Select the first pattern under Line Style for Curve # 0. Select no Symbol for Marker Style and click on the Apply button.

Next select Curve # 1, select the next available Pattern for Line Style, no Symbol for Marker Style, and click on the Apply button. Close the Curves – Solution XY Plot window. Click on the Save/Plot button in the Solution XY Plot window and close this window.

**F** Axes - Solution XY Plot

Axis	Number Format	Major Rules
<input checked="" type="radio"/> X <input type="radio"/> Y	Type float	Color foreground
Label Re-x	Precision 0	Weight 1
Options	Range	Minor Rules
<input checked="" type="checkbox"/> Log <input type="checkbox"/> Auto Range <input type="checkbox"/> Major Rules <input type="checkbox"/> Minor Rules	Minimum 100 Maximum 1000000	Color dark gray Weight 1

Apply Close Help

Figure 2.18b) Axes – Solution XY Plot window settings for X Axis

**F** Axes - Solution XY Plot

Axis	Number Format	Major Rules
<input type="radio"/> X <input checked="" type="radio"/> Y	Type float	Color foreground
Label Cf-x	Precision 3	Weight 1
Options	Range	Minor Rules
<input checked="" type="checkbox"/> Log <input type="checkbox"/> Auto Range <input type="checkbox"/> Major Rules <input type="checkbox"/> Minor Rules	Minimum 0.001 Maximum 0.1	Color dark gray Weight 1

Apply Close Help

Figure 2.18c) Axes – Solution XY Plot window settings for Y Axis

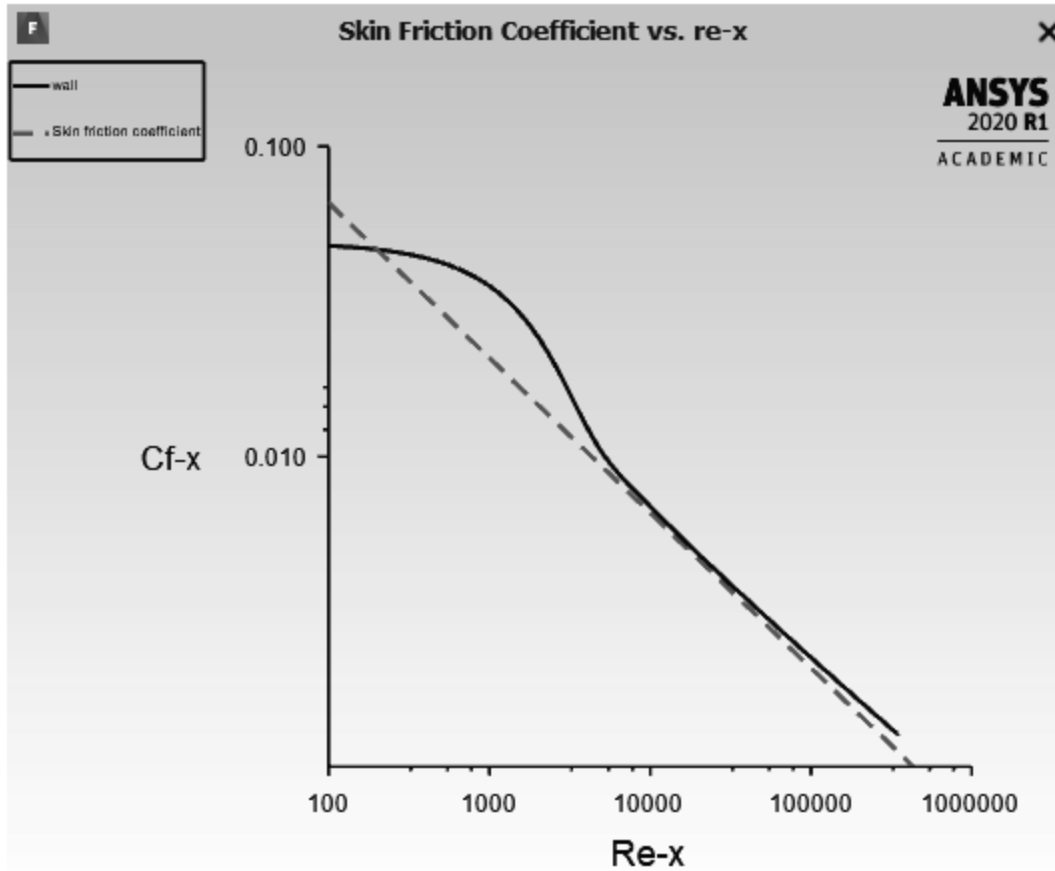

Figure 2.18d) Comparison between ANSYS Fluent and theoretical skin friction coefficient (dashed line) for laminar boundary layer flow on a flat plate

## H. Theory

19. In this chapter we have compared ANSYS Fluent velocity profiles with the theoretical Blasius velocity profile for laminar flow on a flat plate. We transformed the wall normal coordinate to a similarity coordinate for comparison of profiles at different streamwise locations. The similarity coordinate is defined by

$$\eta = y \sqrt{\frac{U}{\nu x}} \quad (2.1)$$

where  $y$  (m) is the wall normal coordinate,  $U$  (m/s) is the free stream velocity,  $x$  (m) is the distance from the streamwise origin of the wall and  $\nu$  (m<sup>2</sup>/s) is the kinematic viscosity of the fluid.

We also used the non-dimensional streamwise velocity  $u/U$  where  $u$  is the dimensional velocity profile.  $u/U$  was plotted versus  $\eta$  for ANSYS Fluent velocity profiles in comparison with the Blasius theoretical profile and they all collapsed on the same curve as per definition of self-similarity. The Blasius boundary layer equation is given by

## CHAPTER 2. FLAT PLATE BOUNDARY LAYER

$$f'''(\eta) + \frac{1}{2}f(\eta)f''(\eta) = 0 \quad (2.2)$$

with the following boundary conditions

$$f(0) = f'(0) = 0, f'(\infty) = 0 \quad (2.3)$$

The Reynolds number for the flow on a flat plate is defined as

$$Re_x = \frac{Ux}{\nu} \quad (2.4)$$

The boundary layer thickness  $\delta$  is defined as the distance from the wall to the location where the velocity in the boundary layer has reached 99% of the free stream value. For a laminar boundary-layer we have the following theoretical expression for the variation of the boundary layer thickness with streamwise distance  $x$  and Reynolds number  $Re_x$ .

$$\delta = \frac{4.91x}{\sqrt{Re_x}} \quad (2.5)$$

The corresponding expression for the boundary layer thickness in a turbulent boundary layer is given by

$$\delta = \frac{0.16x}{Re_x^{1/7}} \quad (2.6)$$

The local skin friction coefficient is defined as the local wall shear stress divided by dynamic pressure.

$$C_{f,x} = \frac{\tau_w}{\frac{1}{2}\rho U^2} \quad (2.7)$$

The theoretical local friction coefficient for laminar flow is determined by

$$C_{f,x} = \frac{0.664}{\sqrt{Re_x}} \quad Re_x < 5 \cdot 10^5 \quad (2.8)$$

and for turbulent flow we have the following relation

$$C_{f,x} = \frac{0.027}{Re_x^{1/7}} \quad 5 \cdot 10^5 < Re_x < 10^7 \quad (2.9)$$

## CHAPTER 2. FLAT PLATE BOUNDARY LAYER

```

sol = NDSolve[{f'''[η] + 0.5 f[η] f''[η] == 0, f[0] == f'[0] == 0, f'[10] == 1}, f, η];
myplot = Plot[f'[η] /. First[sol], {η, 0, 10}, AxesLabel → {"u/U", "η"}];
axisFlip # /. {x_Line | x_GraphicsComplex ⇒ MapAt[#~Reverse~2 &, x, 1],
  x : (PlotRange → _) ⇒ x~Reverse~2} &;
myplot // axisFlip

SetDirectory["C:\\Users\\jmatsson"];
mylist = Table[{f'[η] /. First[sol], η}, {η, 0, 10, 0.5}];
TableOfValues1 = Prepend[mylist, {""}];
TableOfValues1 = Prepend[TableOfValues1, {"(xy/key/label \"Blasius profile\")"}];
TableOfValues1 = Prepend[TableOfValues1, {""}];
TableOfValues1 = Prepend[TableOfValues1, {"(labels \"X Velocity\" \"η-Coordinate\")"}];
TableOfValues1 = Prepend[TableOfValues1, {"(title \"Theory\")"}];
TableOfValues1 = Append[TableOfValues1, {""}];
Grid[TableOfValues1]
Export["blasius.dat", TableOfValues1]

```

Figure 2.19 Mathematica code for theoretical Blasius laminar boundary layer

### I. References

1. Çengel, Y. A., and Cimbala J.M., Fluid Mechanics Fundamentals and Applications, 1<sup>st</sup> Edition, McGraw-Hill, 2006.
2. Richards, S., Cimbala, J.M., Martin, K., ANSYS Workbench Tutorial – Boundary Layer on a Flat Plate, Penn State University, 18 May 2010 Revision.
3. Schlichting, H., and Gersten, K., Boundary Layer Theory, 8th Revised and Enlarged Edition, Springer, 2001.
4. White, F. M., Fluid Mechanics, 4th Edition, McGraw-Hill, 1999.

### J. Exercises

- 2.1 Use the results from the ANSYS Fluent simulation in this chapter to determine the boundary layer thickness at the streamwise positions as shown in the table below. Fill in the missing information in the table.  $U_\delta$  is the velocity of the boundary layer at the distance from the wall equal to the boundary layer thickness and  $U$  is the free stream velocity.

$x$ (m)	$\delta$ (mm) Fluent	$\delta$ (mm) Theory	Percent Difference	$U_\delta$ (m/s)	$U$ (m/s)	$\nu$ (m <sup>2</sup> /s)	$Re_x$
0.2						.0000146	
0.4						.0000146	
0.6						.0000146	
0.8						.0000146	

Table 2.1 Comparison between Fluent and theory for boundary layer thickness

## CHAPTER 2. FLAT PLATE BOUNDARY LAYER

- 2.2 Change the element size to 2 mm for the mesh and compare the results in XY Plots of the skin friction coefficient versus Reynolds number with the element size 1 mm that was used in this chapter. Compare your results with theory.
- 2.3 Change the free stream velocity to 3 m/s and create an XY Plot including velocity profiles at  $x = 0.1, 0.3, 0.5, 0.7$  and  $0.9$  m. Create another XY Plot with self-similar velocity profiles for this lower free stream velocity and create an XY Plot for the skin friction coefficient versus Reynolds number.
- 2.4 Use the results from the ANSYS Fluent simulation in Exercise 2.3 to determine the boundary layer thickness at the streamwise positions as shown in the table below. Fill in the missing information in the table.  $U_\delta$  is the velocity of the boundary layer at the distance from the wall equal to the boundary layer thickness and  $U$  is the free stream velocity.

$x$ (m)	$\delta$ (mm) Fluent	$\delta$ (mm) Theory	Percent Difference	$U_\delta$ (m/s)	$U$ (m/s)	$\nu$ (m <sup>2</sup> /s)	$Re_x$
0.1						.0000146	
0.2						.0000146	
0.5						.0000146	
0.7						.0000146	
0.9						.0000146	

Table 2.2 Comparison between Fluent and theory for boundary layer thickness

**K. Notes**