

Engineering Design with **SOLIDWORKS® 2021**

A Step-by-Step Project Based Approach
Utilizing 3D Solid Modeling

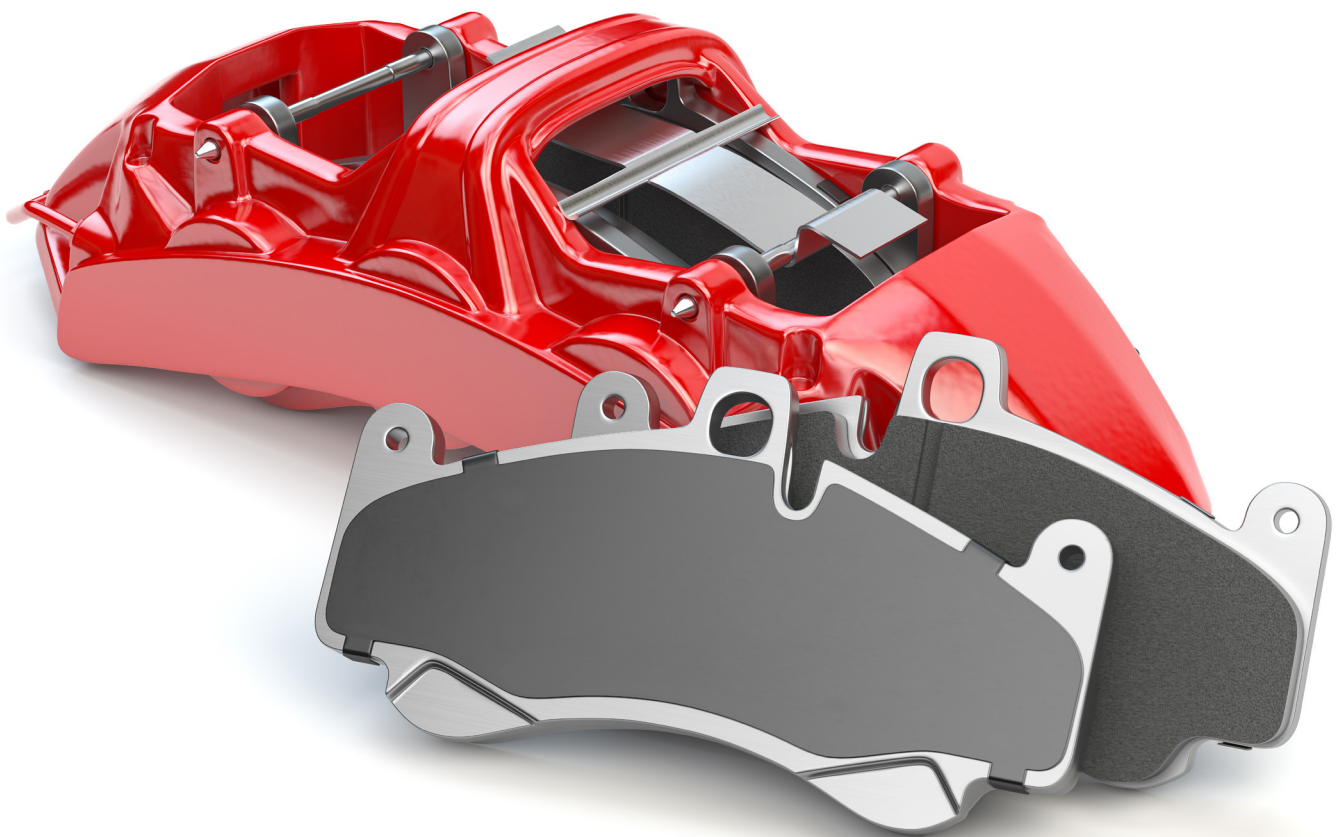

David C. Planchard, CSWP,
SOLIDWORKS Accredited Educator



Better Textbooks. Lower Prices.
www.SDCpublications.com



ACCESS CODE
UNIQUE CODE INSIDE

Visit the following websites to learn more about this book:



[amazon.com](https://www.amazon.com)

[Google books](https://books.google.com)

[BARNES & NOBLE](https://www.barnesandnoble.com)

Project 4

Fundamentals of Drawing

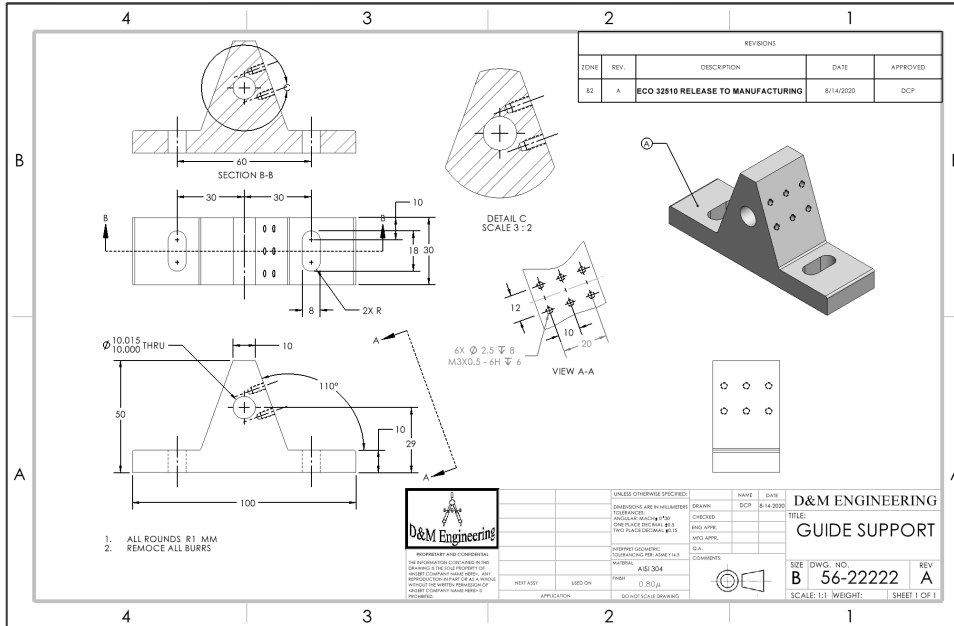

Below are the desired outcomes and usage competencies based on the completion of Project 4.

Project Desired Outcomes:	Usage Competencies:
<ul style="list-style-type: none"> B-ANSI-MM Drawing Template. 	<ul style="list-style-type: none"> Generate a Drawing Template with Document Properties and Sheet Properties.
<ul style="list-style-type: none"> CUSTOM-B Sheet Format. 	<ul style="list-style-type: none"> Produce a Sheet Format with Custom Sheet Properties, Title block, Company logo and more.
<ul style="list-style-type: none"> GUIDE Drawing. 	<ul style="list-style-type: none"> Create Standard Orthographic, Auxiliary, Detail and Section views. Insert, create, and modify dimensions and annotations.
<ul style="list-style-type: none"> GUIDE-ROD Drawing with a Bill of Materials. 	<ul style="list-style-type: none"> Knowledge to develop and incorporate a Bill of Materials with Custom Properties.

Notes:

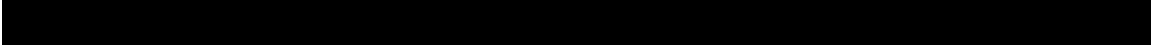

Project 4 - Fundamentals of Drawing

Project Objective

Provide an understanding of Drawing Templates, Part drawings, Assembly drawings, details and annotations.

Create a B-ANSI-MM Drawing Template. Create a CUSTOM-B Sheet Format. The Drawing Template contains Document Property settings. The Sheet Format contains a Company logo, Title block, Revision table and Sheet information.

Create the GUIDE drawing. Display Standard Orthographic, Section, Auxiliary and Detail drawing views. Insert, create and modify part and component dimensions.

Create an Isometric exploded GUIDE-ROD assembly drawing with a Bill of Materials. Obtain knowledge to develop and incorporate a Bill of Materials with Custom Properties.

On the completion of this project, you will be able to:

- Create a new Drawing Template.
- Generate a customized Sheet Format with Custom Properties.
- Open, Save and Close Drawing documents.
- Produce a Bill of Materials with Custom Properties.
- Insert and position views on a Multi Sheet drawing.
- Set the Dimension Layers.
- Insert, move and modify dimensions from a part into a drawing view.
- Insert Annotations: Center Mark, Centerline, Notes, Hole Callouts and Balloons.
- Use Edit Sheet Format and Edit Sheet mode.
- Insert a Revision table.
- Modify dimensioning scheme.
- Create parametric drawing notes.
- Link notes in the Title block to SOLIDWORKS properties.

- Rename parts and drawings.
- Insert a Center of Mass point.

Project Situation

The individual parts and assembly are completed. What is the next step? You are required to create drawings for various internal departments, namely production, purchasing, engineering, inspection and manufacturing. Each drawing contains unique information and specific footnotes. Example: A manufacturing drawing would require information on assembly, Bill of Materials, fabrication techniques and references to other relative documents.

Project Overview

Generate two drawings in this project:

- GUIDE drawing with a customized Sheet Format.
- GUIDE-ROD assembly drawing with a Bill of Materials.

The GUIDE drawing contains three Standard Orthographic views and an Isometric view. Do you remember what the three Principle Orthographic Standard views are? They are Top, Front and Right side (Third Angle Projection).

Three new views are introduced in this project: Detailed view, Section view and Auxiliary view. Orient the views to fit the drawing sheet. Incorporate the GUIDE dimensions into the drawing with inserted Annotations.

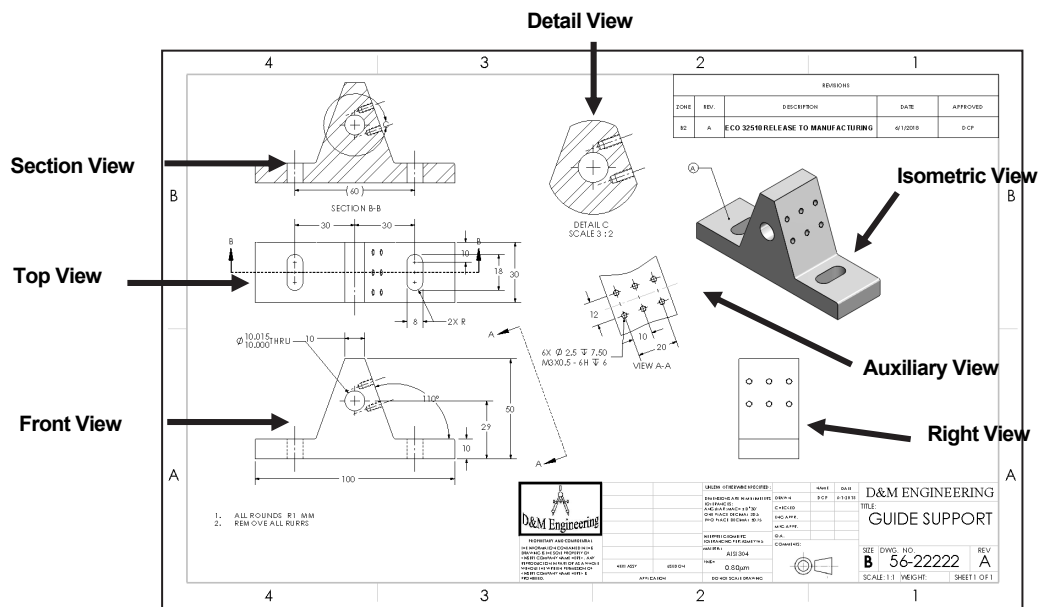

The GUIDE-ROD assembly drawing contains an Isometric Exploded view.

The drawing contains a Bill of Materials with balloon text with bent leaders and magnetic lines.

Both drawings utilize a custom Sheet Format containing a Company logo, Title block and Sheet information.

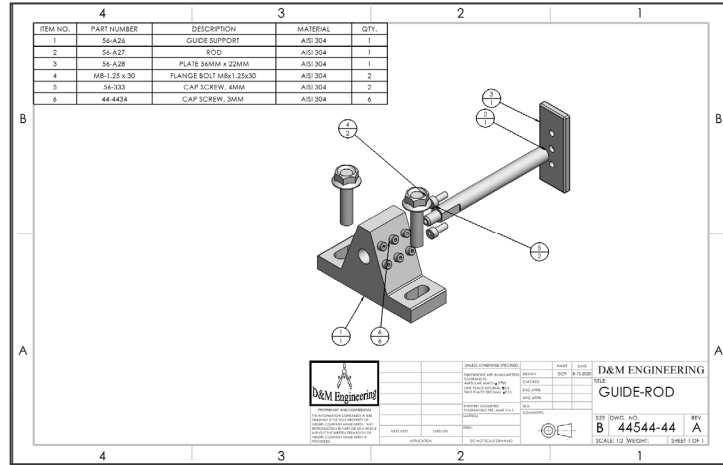

There are two major design modes used to develop a SOLIDWORKS drawing:

- Edit Sheet Format.
- Edit Sheet.

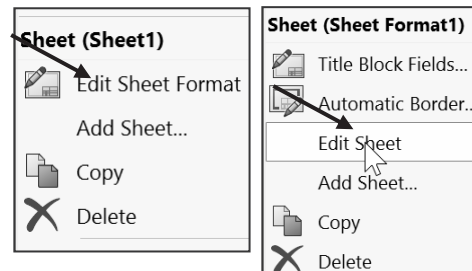

The Edit Sheet Format mode provides the ability to:

- Define the Title block size and text headings.
- Incorporate a company logo.
- Add a picture, design, company text and more.

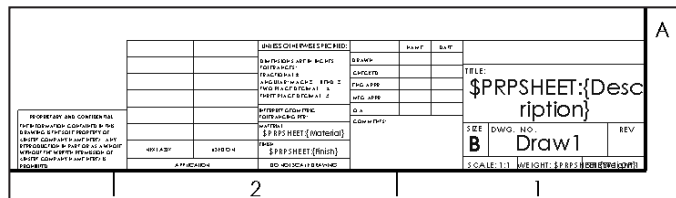

The Edit Sheet mode provides the ability to:

- Add or modify drawing views.
- Add or modify drawing view dimensions.
- Add or modify text and more.

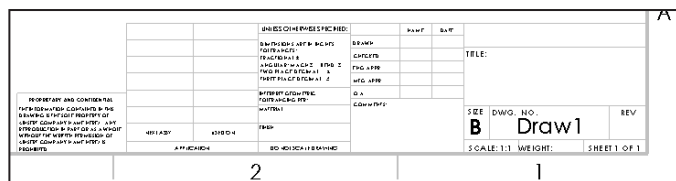

Drawing Template and Sheet Format

The foundation of a SOLIDWORKS drawing document is the Drawing Template. Drawing size, drawing standards, company information, manufacturing, and or assembly requirements, units and other properties are defined in the Drawing Template.

The Sheet Format is incorporated into the Drawing Template. The Sheet Format contains the border, Title block information, revision block information, company name, and or company logo information, Custom Properties, and SOLIDWORKS Properties. Custom Properties and SOLIDWORKS Properties are shared values between documents.

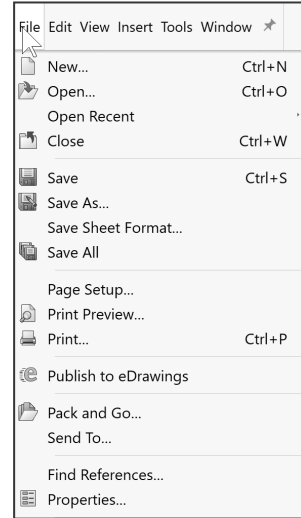

Utilize the standard B (ANSI) Landscape size Drawing Template with no Sheet Format. Set the Units, Font and Layers. Modify a B (ANSI) Landscape size Sheet Format to create a Custom Sheet Format and Custom Drawing Template.

1. Set Sheet Properties and Document Properties for the Drawing Template.
2. Insert Custom Properties: CompanyName, Revision, Number, DrawnBy, DrawnDate, Company Logo, Third Angle Projection Logo, etc. for the Sheet Format.
3. Save the Custom Drawing Template and Custom Sheet Format in the MY-TEMPLATE file folder.

Property Name	Type	Value / Text Expression	Evaluated Value
1 SWFormatSize	Text	215.9mm*279.4mm	215.9mm*279.4mm
2 CompanyName	Text	D&M ENGINEERING	D&M ENGINEERING
3 Department	Text	Mechanical	Mechanical
4 <type a new property>			

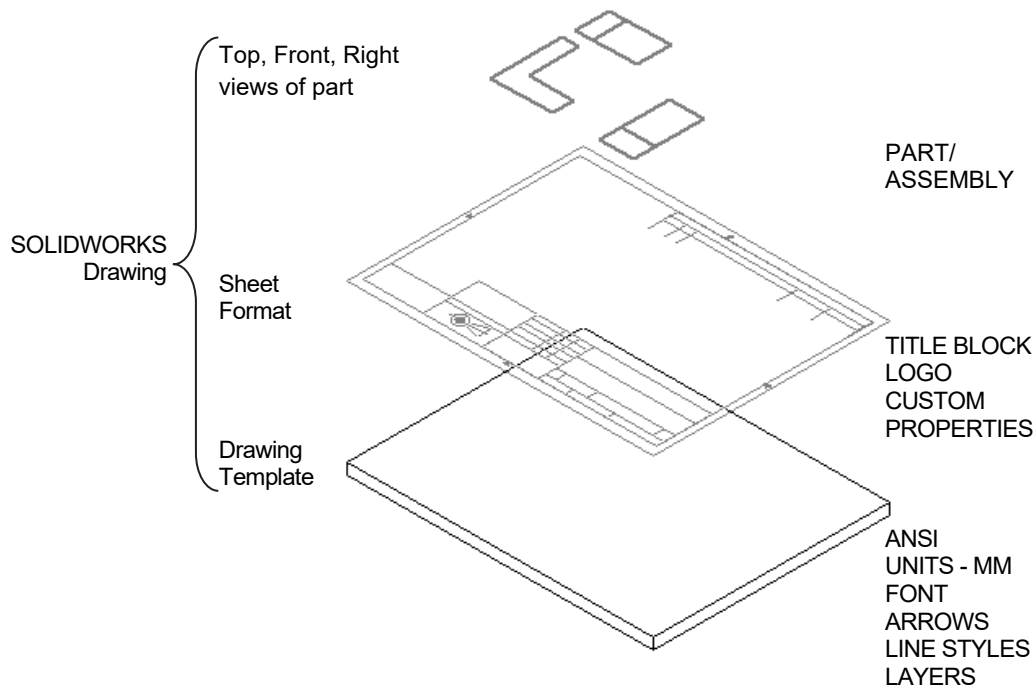

Views from the part or assembly are inserted into the SOLIDWORKS Drawing.

A Third Angle Projection scheme is illustrated in this project. For non-ANSI dimension standards, the dimensioning techniques are the same, even if the displayed arrows and text size are different.

For printers supporting millimeter paper sizes, select A3 (ANSI) Landscape (420mm x 297mm).

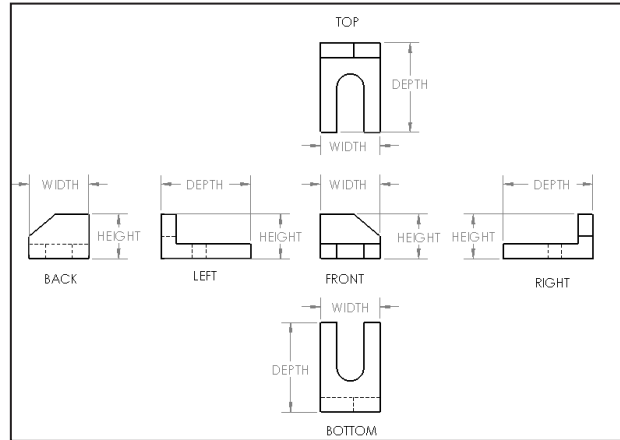

The default Drawing Templates with Sheet Format displayed contain predefined Title block Notes linked to Custom Properties and SOLIDWORKS Properties.

Activity: Create a Drawing Template

Close all documents.

- 1) Click **Window, Close All** from the Menu bar.

Create a B (ANSI) Landscape, Third Angle Projection drawing document.

- 2) Click **New**  from the Menu bar. Double-click **Drawing** from the Templates tab.

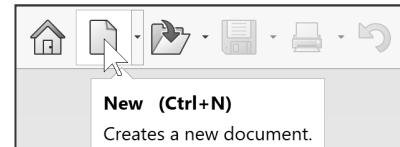

- 3) If needed **uncheck** the **Only show standard formats** box.
- 4) Select **B (ANSI) Landscape** from the Standard sheet size box.
- 5) Click **OK** from the Sheet Format/Size dialog. Accept the default sheet properties.
- 6) If needed, click **Cancel**  from the Model View PropertyManager. Draw1 is the default drawing name. Sheet1 is the default first sheet name.

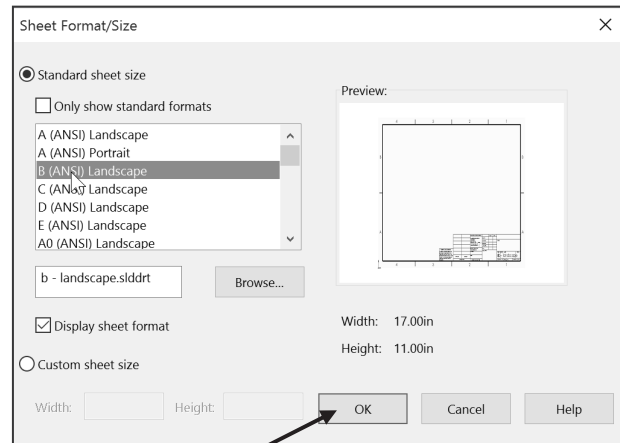

 If the Start command when creating new drawing option is checked, the Model View PropertyManager is selected by default.

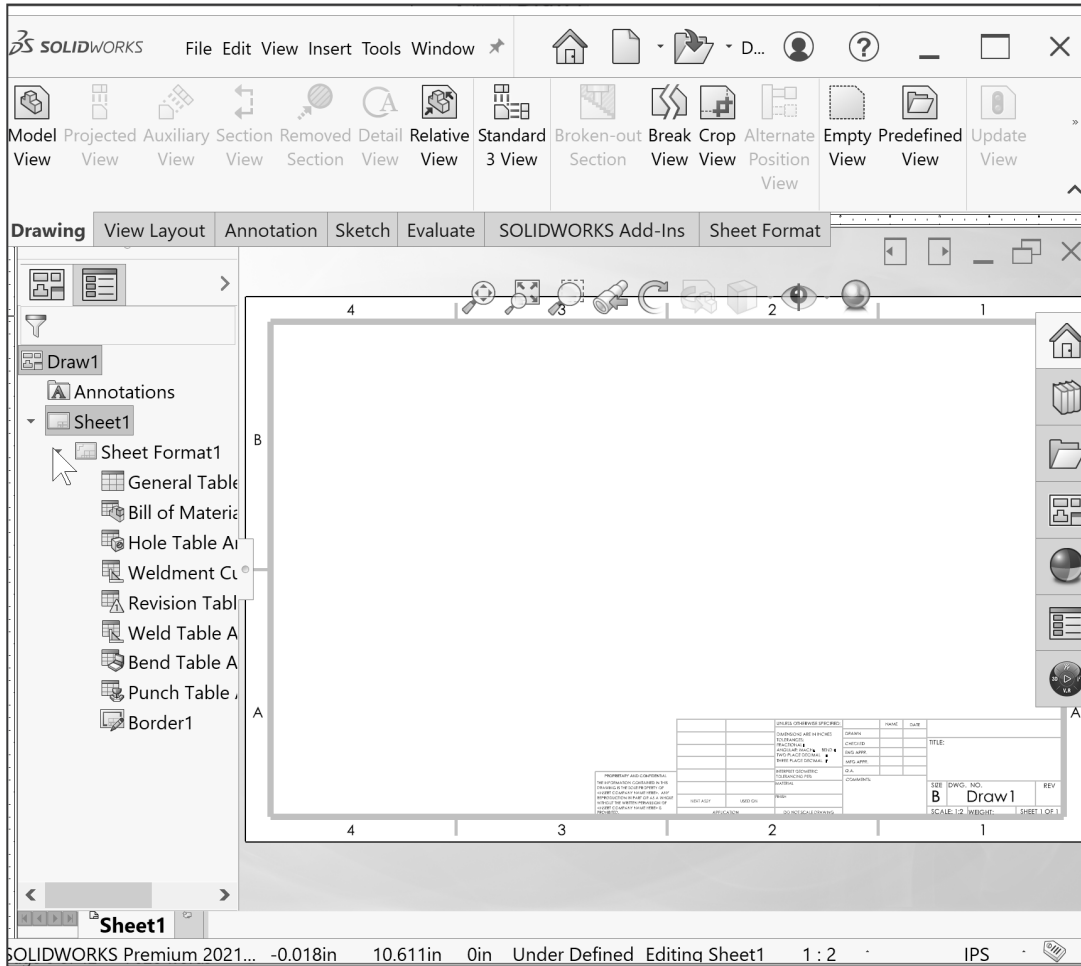

You can define drawing sheet zones on a sheet format for the purpose of providing locations where drawing views and annotations reside on the drawing.

The B (ANSI) Landscape Standard Sheet border defines the drawing size, 17" x 11" (431.8mm x 279.4mm).

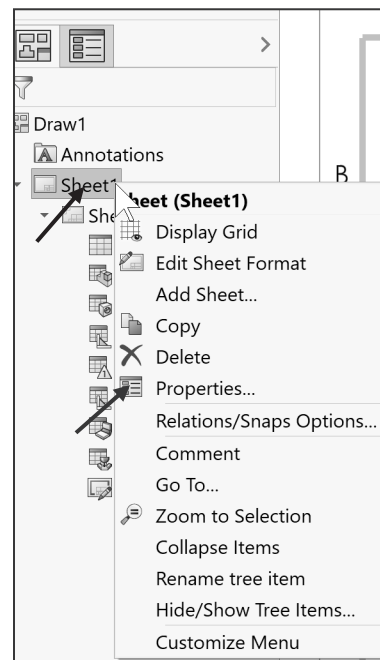

Set Drawing Size, Sheet Properties and Document Properties for the Drawing Template. Sheet Properties control Sheet Size, Sheet Scale and Type of Projection. Document Properties control the display of dimensions, annotations and symbols in the drawing.

Set Sheet Properties. View your options in the Sheet Properties dialog box.

- 7) **Expand** Sheet1 in the Drawing FeatureManager.
- 8) Right-click **Sheet 1** and view your options.
- 9) Click **Properties** . The Sheet Properties dialog box is displayed.
- 10) Select Sheet Scale **1:1**.
- 11) Select **B (ANSI) Landscape** from the Standard sheet size box.
- 12) Select **Third Angle** for Type of projection.
- 13) Click **Apply Changes** from the Sheet Properties dialog box.

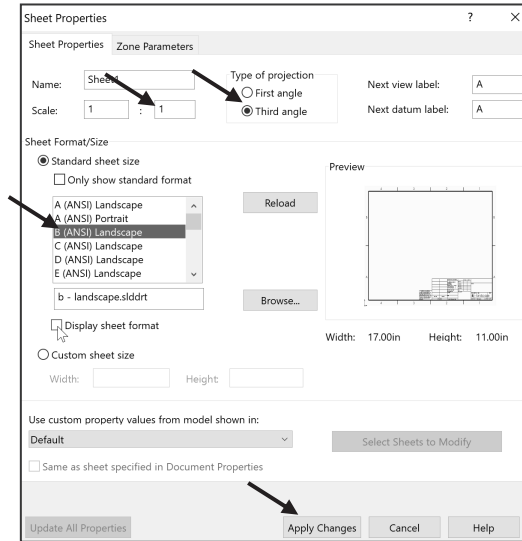

Set Document Properties. Set drafting standard, units, and precision.

- 14) Click **Options** , **Document Properties** tab from the Menu bar.
- 15) Select **ANSI** for Overall drafting standard.
- 16) Click the **Units** folder.
- 17) Select **MMGS** for Unit system.
- 18) Select **.12** for basic unit length decimal place.
- 19) Select **None** for basic unit angle decimal place.

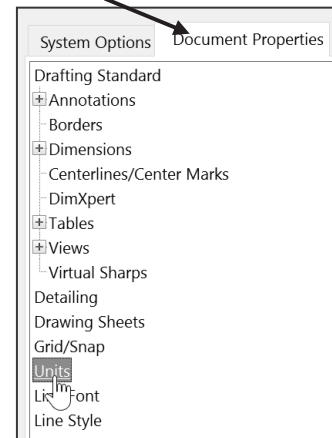

Detailing options provide the ability to address dimensioning standards, text style, center marks, extension lines, arrow styles, tolerance and precision.

There are numerous text styles and sizes available in SOLIDWORKS. Companies develop drawing format standards and use specific text height for Metric and English drawings.

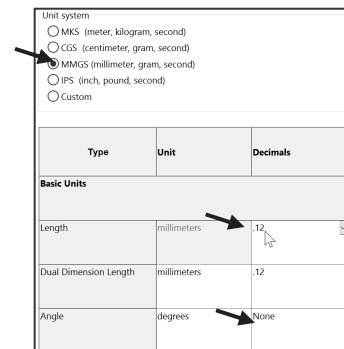

Numerous engineering drawings use the following format:

- Font: Century Gothic - All capital letters.
- Text height: .125in. or 3mm for drawings up to B (ANSI) Size, 17in. x 22in.
- Text height: .156in. or 5mm for drawings larger than B (ANSI) Size, 17in x 22in.
- Arrowheads: Solid filled with a 1:3 ratio of arrow width to arrow height.

Set the Annotations font height.

20) Click the **Annotations** folder.



21) Click the **Font** button.

22) Click the **Units** button.

23) Enter **3.00mm** for Height.

24) Enter **1.00mm** for Space.

25) Click **OK**.

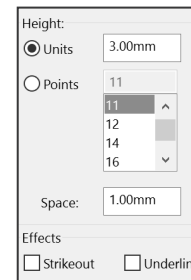

Change the Arrow Height.

26) Click the **Dimensions** folder from the Document Properties column as illustrated.

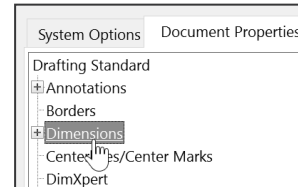

27) Enter **1mm** for arrow Height.

28) Enter **3mm** for arrow Width.

29) Enter **6mm** for arrow Length.

Set Section/Views size.

30) **Expand** the Views folder from the Document Properties column.

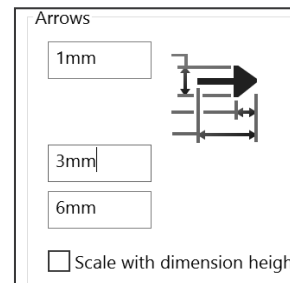

31) Click the **Section** folder.

32) Enter **2mm** for arrow Height.

33) Enter **6mm** for arrow Width.

34) Enter **12mm** for arrow Length.

35) Click **OK** from the Document Properties - Section dialog box.

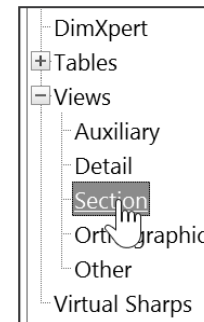

Drawing Layers organize dimensions, annotations and geometry. Create a new drawing layer to contain dimensions and notes. Create a second drawing layer to contain hidden feature dimensions.

Select the Show/Hide eye  to turn On/Off Layers. Dimensions placed on the hidden layers are turned on and off for clarity and can be recalled for parametric annotations.

Display the Layer toolbar.

36) Right-click in the gray area in the Menu bar.

37) Click **Toolbars**. Check **Layer**. The Layer toolbar is displayed. Click and drag the Layer toolbar to the center of the Graphics window.

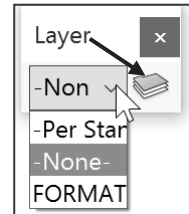
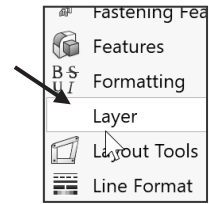

38) Click the **Layer Properties**  file folder from the Layer toolbar. The Layers dialog box is displayed.

Create the Dimension Layer.

39) Click the **New** button. Enter **Dim** in the Name column.

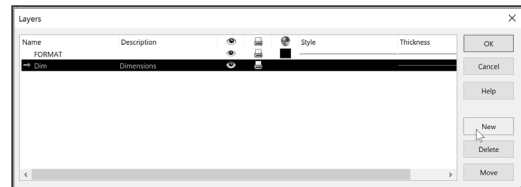

40) Double-click under the Description column. Enter **Dimensions** in the Description column.

Create the Notes Layer.

41) Click the **New** button. Enter **Notes** for Name. Double-click under the Description column.



42) Enter **General Notes** for Description.

Create the Hidden Dims Layer.

43) Click the **New** button. Enter **Hidden Dims** for Name. Double-click under the Description column. Enter **Hidden Insert Dimensions** for Description.



Dimensions placed on the Hidden Dims Layer are not displayed on the drawing until the Hidden Dims Layer status is On. Set the Layer Color to locate dimensions on this layer easily.

Turn the Hidden  Insert Dimension Layer Off.

44) Click **On/Off** . The row is displayed in black.



Set the Layer  Color.

45) Click the **small black square** in the Hidden Dims row as illustrated.

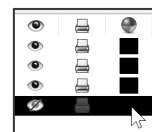

Select a Color Swatch from the Color dialog box.

46) Select **Dark Blue**.

47) Click **OK**.

48) Click **OK** from the Layers dialog box.

The current Layer is Hidden Dims. Set the current Layer to None before saving the Drawing Template.

Set None for Layer.

49) Click the **Layer drop-down arrow**.

50) Click **None**. None is displayed in the Layer toolbar.

51) Drag the **Layer toolbar** out of the Graphics area.

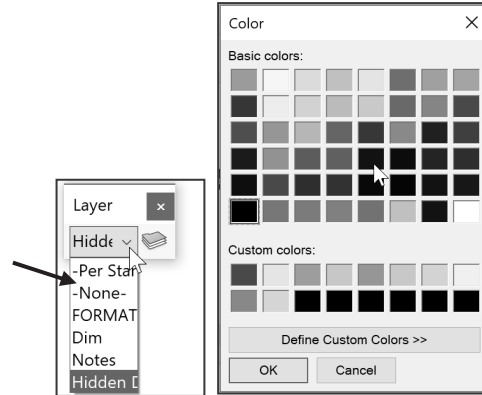

The Drawing Template contains the drawing Size, Document Properties and Layers. The Overall drafting standard is ANSI and the Units are in millimeters. The current Layer is set to None. The Drawing Template requires a Sheet Format. The Sheet Format contains Title block information. The Title block contains vital part or assembly information. Each company may have a unique version of a Title block.

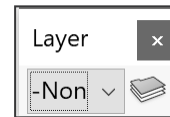

Sheet Format and Title block

The Sheet Format contains the Title block, Revision block, Company logo, Custom Properties, Zones, etc. The Title block contains text fields linked to System Properties and Custom Properties.

System Properties are determined from the SOLIDWORKS documents. Custom Property values are assigned to named variables. Save time. Utilize System Properties and define Custom Properties in your Sheet Formats.

System Properties Linked to fields in default Sheet Formats:	Custom Properties of drawings linked to fields in default Sheet Formats:		Custom Properties of parts and assemblies linked to fields in default Sheet Formats:
SW-File Name (in DWG. NO. field):	CompanyName:	EngineeringApproval:	Description (in TITLE field):
SW-Sheet Scale:	CheckedBy:	EngAppDate:	Weight:
SW-Current Sheet:	CheckedDate:	ManufacturingApproval:	Material:
SW-Total Sheets:	DrawnBy:	MfgAppDate:	Finish:
	DrawnDate:	QAApproval:	Revision:
	EngineeringApproval:	QAAppDate:	

Utilize the standard landscape B (ANSI) Sheet Format (17in. x 11in.) or the standard-A (ANSI) Sheet Format (420mm x 297mm) to create a Custom Sheet Format.

Activity: Sheet Format and Title block

Display the standard B (ANSI) Landscape Sheet Format.

52) Right-click in the **Graphics window**.

53) **Expand** the drop-down menu.

54) Click **Properties**. The Sheet Properties dialog box is displayed.

55) Click the **Standard sheet size** box.

56) Select **B (ANSI) Landscape**.

57) Check the **Display sheet format** box. The default Sheet Format, b - landscape.slddrt is displayed.

58) Click **Apply Changes** from the Sheet Properties dialog box.

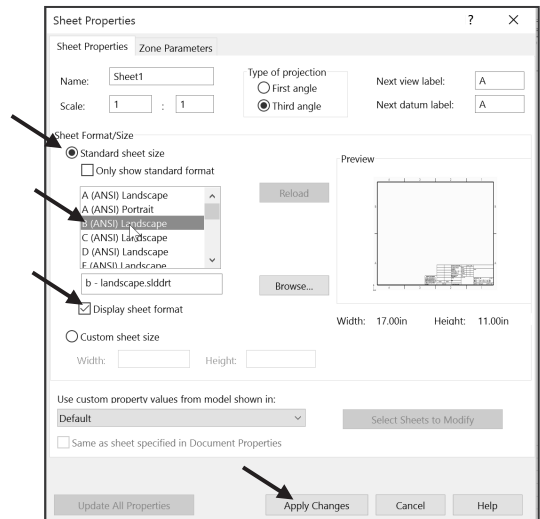
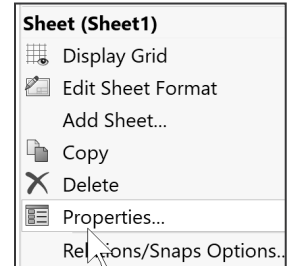

The default Sheet Format is displayed in the Graphics window. The FeatureManager displays Draw1, Sheet 1.

A SOLIDWORKS drawing contains two edit modes:

1. Edit Sheet.

2. Edit Sheet Format.

Insert views and dimensions in the Edit Sheet mode.

Modify the Sheet Format text, lines or Title block information in the Edit Sheet Format mode.

The CompanyName Custom Property is located in the Title block above the TITLE box. There is no value defined for CompanyName. A small text box indicates an empty field. Define a value for the Custom Property CompanyName. Example: D&M ENGINEERING.

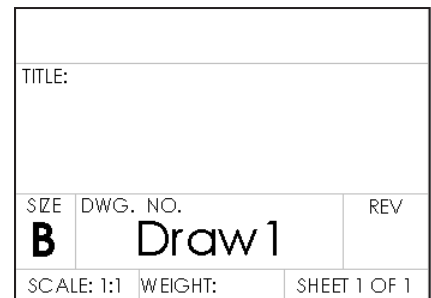

Activate the Edit Sheet Format mode.

59) Right-click in the **Graphics window**.

60) Click **Edit Sheet Format**. The Title block lines turn blue.

View the right side of the Title block.

61) Click **Zoom to Area** . **Zoom in** on the Sheet Format Title block.

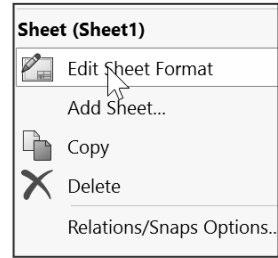

62) Click **Zoom to Area**  to deactivate.

Define CompanyName Custom Property.

63) Position the **mouse pointer** in the middle of the box above the TITLE box. The mouse pointer displays Sheet Format1. The box also contains the hidden text, linked to the CompanyName Custom Property.

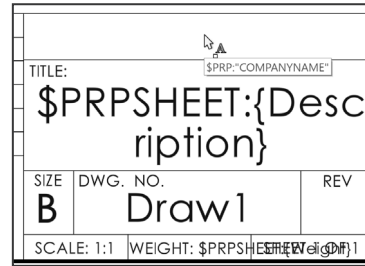

64) Click **File, Properties** from the Menu bar. The Summary Information dialog box is displayed.

65) Click the **Custom** tab.

66) Click inside the **Property Name** box.

67) Click the **drop-down arrow**  in the Property Name box.

68) Select **CompanyName** from the Property list.

69) Enter **D&M ENGINEERING** (your company or school name) in the Value/Text Expression box.

70) Click inside the **Evaluated Value** box. The CompanyName is displayed in the Evaluated Value box.

71) Click **OK**. The Custom Property "\$PRP:COMPANYNAME," Value "D&M ENGINEERING" is displayed in the Title block.

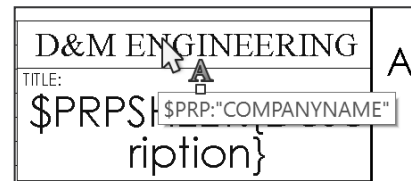
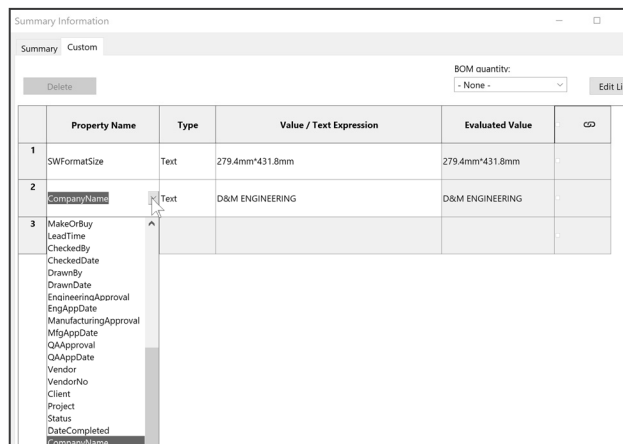

Modify the font size.

72) Double-click **D&M ENGINEERING**. The Formatting dialog box and the Note PropertyManager is displayed.

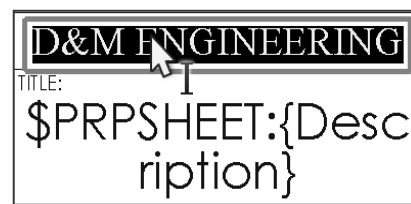

73) Click the **drop-down arrows** to set the Text Font and Height.



74) Click the **Style buttons** and **Justification buttons** to modify the selected text.

75) Click **OK**  from the Note PropertyManager. View the results.



Click a position outside the selected text box to save and exit the text.

The Tolerance block is located in the Title block. The Tolerance block provides information to the manufacturer on the minimum and maximum variation for each dimension on the drawing. If a specific tolerance or note is provided on the drawing, the specific tolerance or note will override the information in the Tolerance block.

General tolerance values are based on the design requirements and the manufacturing process.



Create Sheet Formats for different parts types. Example: sheet metal parts, plastic parts and high precision machined parts. Create Sheet Formats for each category of parts that are manufactured with unique sets of Title block notes.

Modify the Tolerance block in the Sheet Format for ASME Y14.5-2009 machined, millimeter parts. Delete unnecessary text. The FRACTIONAL text refers to inches. The BEND text refers to sheet metal parts. The Three Decimal Place text is not required for this millimeter part.

Modify the Tolerance Note.

76) Double-click the text **INTERPRET GEOMETRIC TOLERANCING PER:**

77) Enter **ASME Y14.5** as illustrated.

78) Click **OK**  from the Note PropertyManager.

79) Double-click inside the **Tolerance block** text. The Formatting dialog box and the Note PropertyManager is displayed.

80) Delete the text **INCHES**.

81) Enter **MILLIMETERS**.

82) Delete the line **FRACTIONAL +/-**.

83) Delete the text **BEND +/-**.

Enter ANGULAR tolerance.

84) Click a **position** at the end of the line.

85) Enter **0**. Click **Add Symbol**  from the Text Format box.

86) Select **Degree** from the Modifying Symbols library.

87) Enter **30'** for minutes of a degree.

Modify the TWO and THREE PLACE DECIMAL LINES.

88) Delete the **TWO** and **THREE PLACE DECIMAL** lines.

89) Enter **ONE PLACE DECIMAL +/- 0.5**.

90) Enter **TWO PLACE DECIMAL +/- 0.15**.

91) Click **OK**  from the Note PropertyManager.

92) Right-click **Edit Sheet** in the Graphics window.

Save Draw1. Fit the drawing to the Graphics window.

93) Press the **f** key.

94) Click **Save** . Accept the default name. View the results.

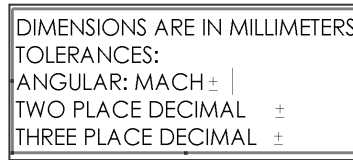

DIMENSIONS ARE IN MILLIMETERS
TOLERANCES:
ANGULAR: MACH ± |
TWO PLACE DECIMAL ±
THREE PLACE DECIMAL ±

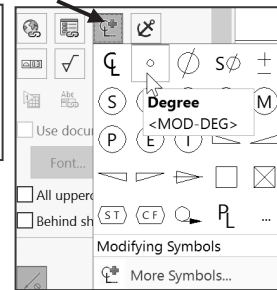
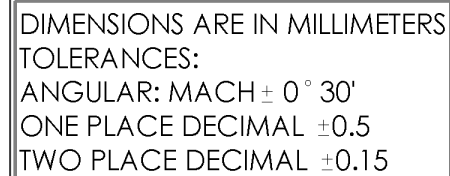
DIMENSIONS ARE IN MILLIMETERS
TOLERANCES:
ANGULAR: MACH ± 0° 30'
ONE PLACE DECIMAL ±0.5
TWO PLACE DECIMAL ±0.15

Various symbols are available through the Symbol button in the Text dialog box. The ± symbol is located in the Modify Symbols list. The ± symbol is displayed as <MOD-PM>. The degree symbol ° is displayed as <MOD-DEG>.

Interpretation of tolerances is as follows:

- The angular dimension 110 is machined between 109.5 and 110.5.
- The dimension 2.5 is machined between 2.0 and 3.0.
- The Guide Hole dimension 10.000/10.015 is machined according to the specific tolerance on the drawing.

Company Logo

A Company logo is normally located in the Title block of the drawing. Create your own Company logo or copy and paste an existing picture.

If you have your own Logo, skip the process of copying and applying the LOGO folder and file shown below.

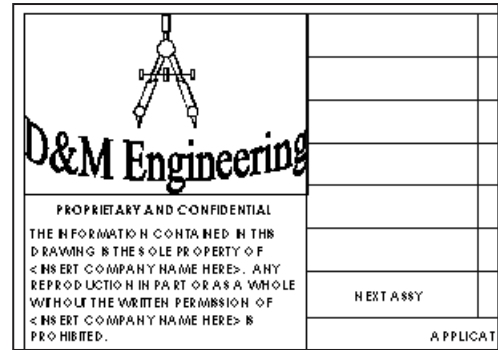

Activity: Insert a Company Logo

Insert a Company or School Logo.

- 95) Copy the **LOGO** folder to your hard drive. Note: If you have your own Logo, use it for the drawing.
- 96) Right-click **Edit Sheet Format** in the Graphics window.
- 97) Click **Insert, Picture** from the Menu bar. The Open dialog box is displayed.
- 98) Double-click the **Logo.jpg** file. The Sketch Picture PropertyManager is displayed.
- 99) Un-check the **Enable scale tool** box.
- 100) Un-check the **Lock aspect ratio** box.
- 101) Drag the picture handles to size the **picture** to the left side of the Title block
- 102) Click **OK**  from the Sketch Picture PropertyManager.

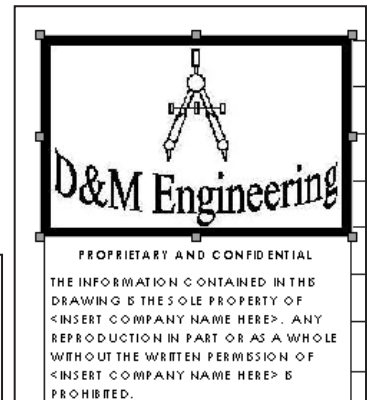
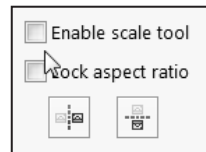
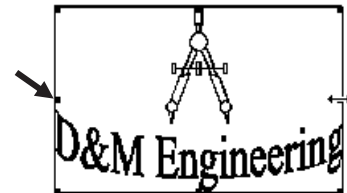

 Text can be added to create a custom logo. You can insert a picture or an object.

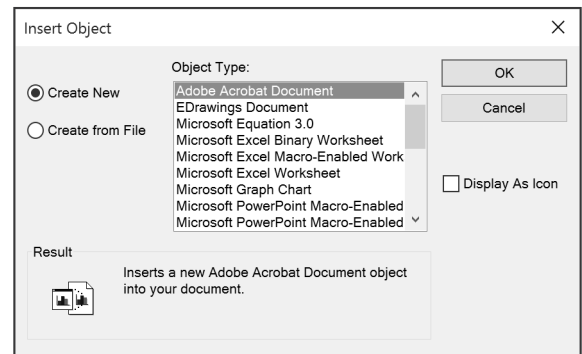

Return to the Edit Sheet mode.

103) Right-click in the **Graphics window**.

104) Click **Edit Sheet**. The Title block is displayed in black.

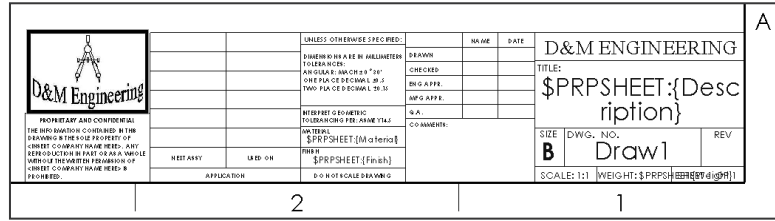

Fit the Sheet Format to the Graphics window.

105) Press the **f** key.

Draw1 displays Editing Sheet1 in the Status bar. The Title block is displayed in black when in Edit Sheet mode.

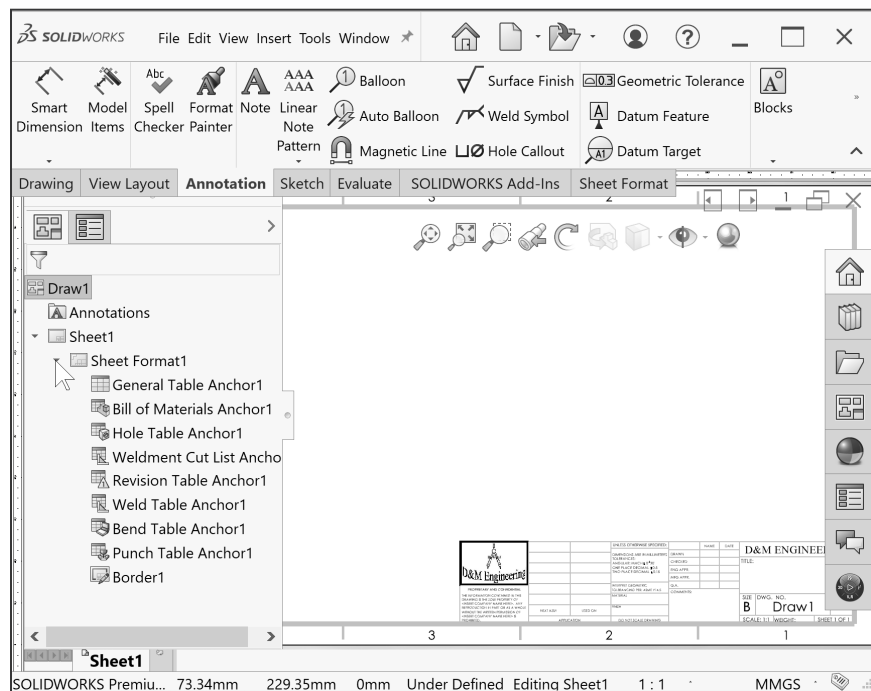

Save Sheet Format and Save As Drawing Template

Save the drawing document in the Graphics window in two forms: Sheet Format and Drawing Template. Save the Sheet Format as a custom Sheet Format named CUSTOM-B. Use the CUSTOM-B (ANSI) Sheet Format for the drawings in this project. The Sheet format file extension is .slddrt.

The Drawing Template can be displayed with or without the Sheet Format. Combine the Sheet Format with the Drawing Template to create a custom Drawing Template named B-ANSI-MM. Utilize the File, Save As option to save a Drawing Template. The Drawing Template file extension is .drwdot.



Select the Save as type option first, then select the Save in folder to avoid saving in default SOLIDWORKS installation directories.

Talk to your IT department *before you set* any locations on a network system. The procedure below is designed for your personal computer.

Note: If you do not create the templates or the MY-TEMPLATES tab, use a standard SOLIDWORKS drawing template and address the needed document properties and Custom properties.

Activity: Save Sheet Format. Utilize the Save As Option for the Drawing Template.

Save the Sheet Format.

106) Click **File, Save Sheet Format** from the Menu bar. The Save Sheet Format dialog box is displayed. The file extension for Sheet Format is .slddrt.

107) Select **ENGDESIGN-W-SOLIDWORKS\MY-TEMPLATES** for Save In File Folder.

108) Enter **CUSTOM-B** for File name.

109) Click **Save** from the Save Sheet Format dialog box.



The Automatic Border tool provides the ability to control every aspect of a sheet format's border, including zone layout and border size.

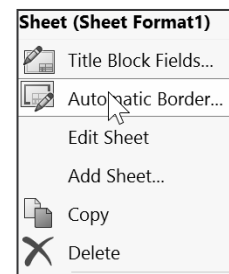

Save the Drawing Template.

110) Click **Save As** .

111) Click **Drawing Templates (*.drwdot)** from the Save as type box.

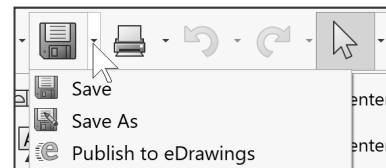

112) Select **ENGDESIGN-W-SOLIDWORKS\MY-TEMPLATES** for Save In File Folder.

113) Enter **B-ANSI-MM** for File name.

114) Click **Save**.

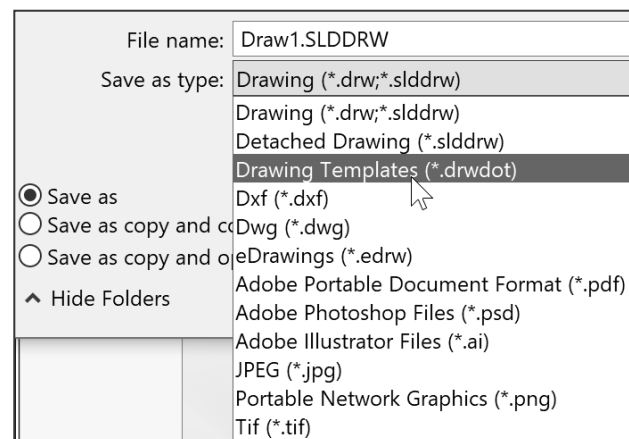

If you created the MY-TEMPLATES tab in Project 2, skip this section. Set System Options - File Locations.

115) Click **Options**  from the Menu bar. The System Options General dialog box is displayed.

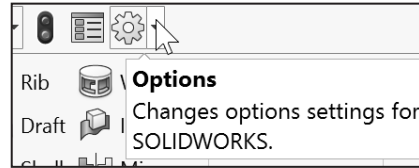

116) Click the **File Locations** folder.

Add a new tab.

117) Click the **Add** button.

118) Browse to the **ENGDESIGN-W-SOLIDWORKS\MY-TEMPLATES** folder.

119) Click **Select Folder**. You should see the new folder added to the Document Templates. If needed, click the **Move Down** button.

120) Click **OK** from the System Options, File Locations dialog box.

121) Click **Yes** to the SOLIDWORKS dialog box. The SOLIDWORKS dialog box displays the new Folder location.

122) Click **Yes**.

123) Click **Yes**.

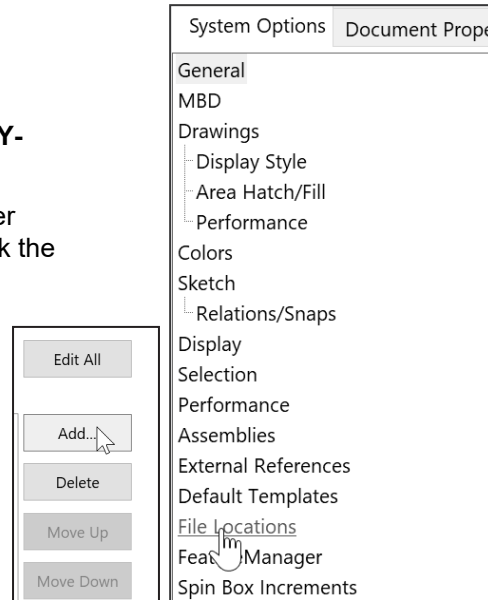

Close all files.

124) Click **Window, Close All** from the Menu bar. SOLIDWORKS remains open, and no documents are displayed.



Talk to your IT department *before you set* any locations on a network system. Your document templates and tutorial location will vary depending on your network system setup.

Utilize Drawing Template descriptive filenames that contain the size, dimension standard and units.



Combine customized Drawing Templates and Sheet Formats to match your company's drawing standards. Save the empty Drawing Template and Sheet Format separately to reuse information.

Note: If you do not create the templates or the MY-TEMPLATES tab, use a standard SOLIDWORKS drawing template and address the needed document properties and custom properties.

 Additional details on Drawing Templates, Sheet Format and Custom Properties are available in SOLIDWORKS Help Topics.

Keywords: Documents (templates, properties); Sheet Formats (new, new drawings, note text); Properties (drawing sheets); Customized Drawing Sheet Formats.

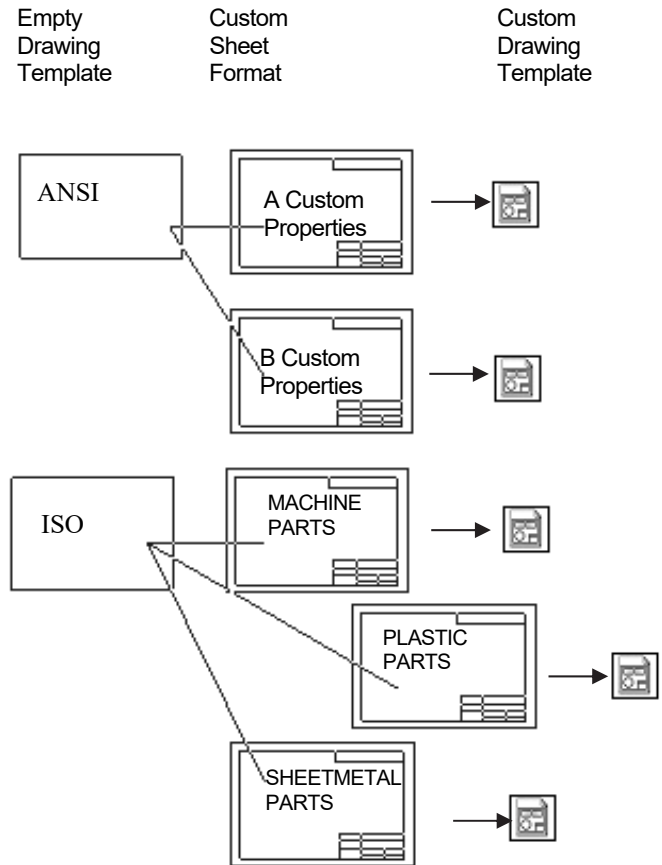

Review Drawing Templates

A custom Drawing Template was created from the default Drawing Template. You modified Sheet Properties and Document Properties to control the Sheet size, scale, annotations, dimensions and layers.

The Sheet Format contained Title block and Custom Property information. You inserted a Company Logo and modified the Title block.

The Save Sheet Format option was utilized to save the CUSTOM-B.SLDDRT Sheet Format. The File, Save As option was utilized to save the B-ANSI-MM.DRWDOT Template. The Sheet Format and Drawing Template were saved in the MY-TEMPLATES folder.

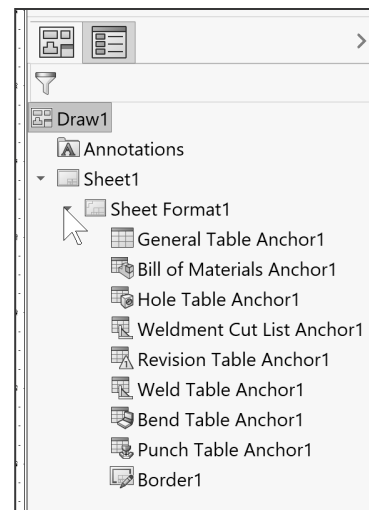

GUIDE Part - Modify

A drawing contains part views, geometric dimensioning and tolerances, centerlines, center marks, notes, custom properties and other related information. Perform the following tasks before starting the GUIDE drawing:

- Verify the part. The drawing requires the associated part.
- View dimensions in each part. Step through each feature of the part and review all dimensions.
- Review the dimension scheme to determine the required dimensions and notes to manufacture the part.

Activity: GUIDE Part - Modify

Open the GUIDE part.

125) Click **Open**  from the Menu bar.

126) Select the **folder** that the GUIDE document is in.

Modify the dimensions.

127) Double-click **GUIDE**.

128) Click **Hidden Lines Visible**  from the Heads-up View toolbar.

129) Double-click **Base-Extrude** from the GUIDE FeatureManager.

130) Click the **80** dimension.

131) Enter **100mm**. Click **inside** the Graphics window.

Display a Shaded With Edges view. Save the GUIDE part.

132) Click **Shaded With Edges**  from the Heads-up View toolbar.

133) Click **Save** .

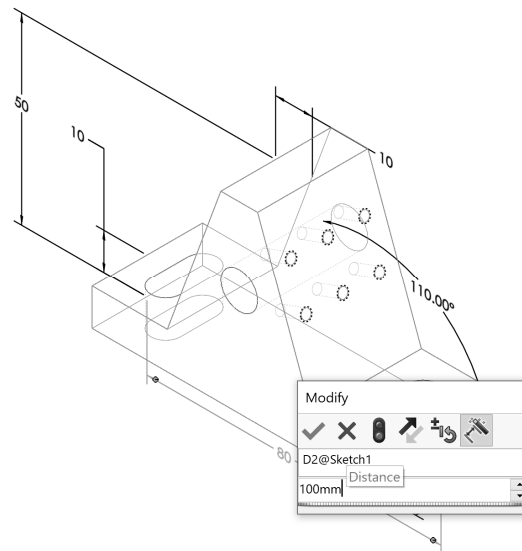
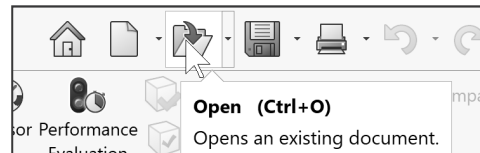

Review part history with the Rollback bar to understand how the part was created. Position the Rollback bar at the top of the FeatureManager. Drag the Rollback bar below each feature. When working between features, right-click in the FeatureManager. Select Roll to Previous/Roll to End.

GUIDE Part - Drawing

The GUIDE drawing consists of multiple views, dimensions and annotations. The GUIDE part was designed for symmetry. Add or redefine dimensions in the drawing to adhere to a Drawing Standard. Add dimensions and notes to the drawing in order to correctly manufacture the part.

Address the dimensions for three features:

- The right Slot Cut is not dimensioned to an ASME Y14 standard.
- No dimensions exist for the left Mirror Slot Cut.
- The Guide Hole and Linear Pattern of Tapped Holes require notes.

The GUIDE part remains open. Create a new GUIDE drawing. Utilize the B-ANSI-MM Drawing Template. Utilize the Model View  tool to insert the Front view into Sheet1. Utilize the Auto-start Projected View option to project the Top, Right and Isometric views from the Front view. Note: You can also use the View Palette in the Task Pane.

Activity: GUIDE Part - Drawing

Create the GUIDE Drawing.

134) Click **New**  from the Menu bar.

135) Double-click **B-ANSI-MM** from the MY-TEMPLATES tab. The Model View PropertyManager is displayed.

136) Click **Cancel**  from the Model View PropertyManager. The Draw# FeatureManager is displayed.

Review the Draw# FeatureManager.

137) Expand Sheet1 from the FeatureManager.

138) Expand Sheet Format1 from the FeatureManager. View your options.

 The current drawing name is Draw2 if the second new drawing is created in the same session of SOLIDWORKS. The current sheet name is Sheet1. Sheet1 is the current Sheet.

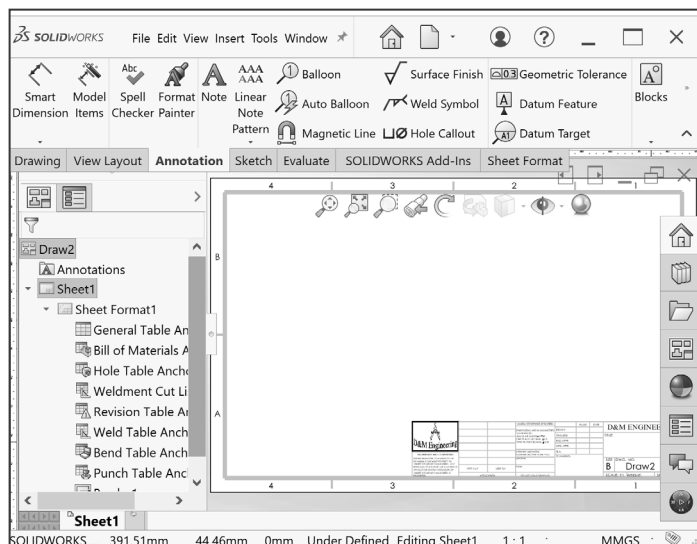

Insert four Drawing Views.

139) Click **Model View**  from the View Layout tab in the CommandManager. The Model View PropertyManager is displayed.

140) Double-click **GUIDE** from the Part/Assembly to Insert box.

Insert four views.

141) Expand the Orientation dialog box. Check the **Create multiple views** box.

142) Click **Front**, **Top** and **Right** from the Orientation box. Note: All four views are selected. *Isometric should be selected by default.

143) Click **OK**  from the Model View PropertyManager. Four views are displayed on Sheet1.

144) Click inside the **Isometric view boundary**. Drawing View4 PropertyManager is displayed.

145) Click **Shaded With Edges**  from the Display Style box.

146) Click **OK**  from the Drawing View4 PropertyManager. If required, hide any annotations, origins or dimensions as illustrated.

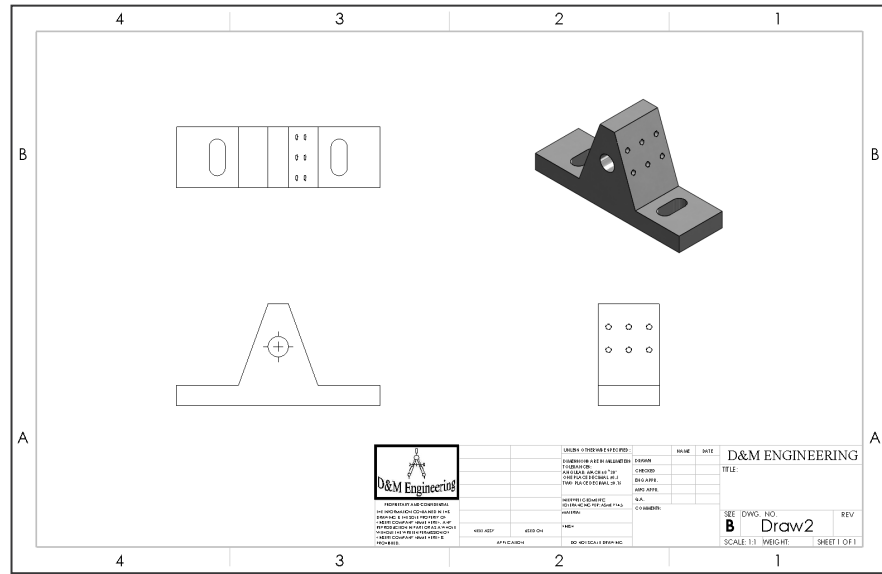
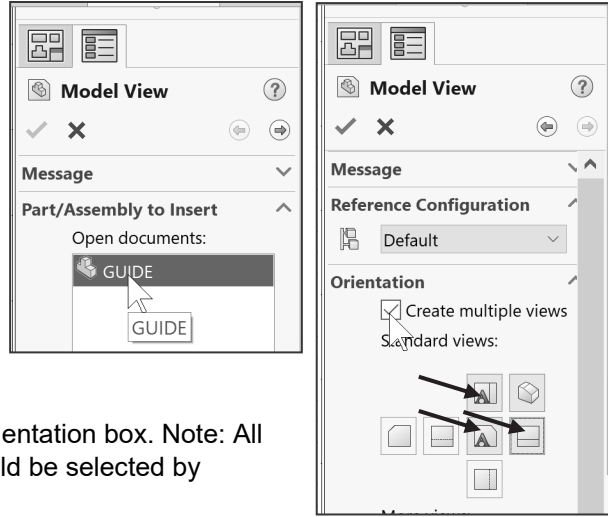

 By default, the Center marks-holes box is checked under **Options, Document Properties, Detailing** from the Menu bar.

Save the GUIDE drawing. Enter name.

147) Click **Save As** .

148) Select **PROJECTS** for Save in folder.

149) Enter **GUIDE** for file name. Drawing is the default Save as type.

150) Click **Save**. Note: The correct display modes need to be selected, dimensions to be added, along with Center Marks, Centerlines, additional views, Custom Properties, etc.



The DWG. NO. box in the Title block displays the part File name, GUIDE. The TITLE: box in the Title block displays GUIDE SUPPORT.

Predefined text in the CUSTOM-B Sheet Format links the Properties: \$PRPSHEET:“Description” and \$PRP:“SW-FileName.” The Properties were defined in the GUIDE part utilizing File, Save As. Properties in the Title block are passed from the part to the drawing.

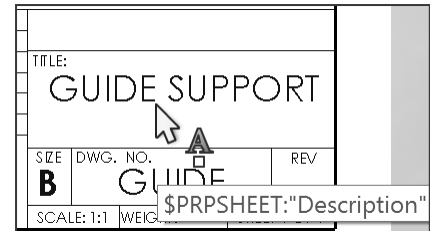

 Always confirm the File name and Save in folder. Projects deal with multiple File names and folders. Select Save as type from the drop down list. Do not enter the extension. The file extension is entered automatically.

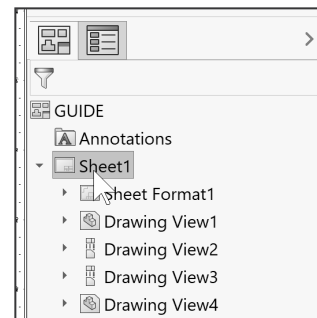

Each drawing has a unique file name. Drawing file names end with a .SLDDRW suffix. Part file names end with a .SLDPRT suffix. A drawing or part file can have the same prefix. A drawing or part file **can't have the same suffix**.

Example: Drawing file name
GUIDE.SLDDRW. Part file name
GUIDE.SLDPRT. The current file name is
GUIDE.SLDDRW.

The GUIDE drawing contains three Principle views (Standard Orthographic views): Front, Top, Right and an Isometric view. You created the views with the Model View option.

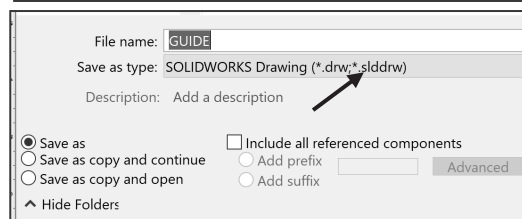
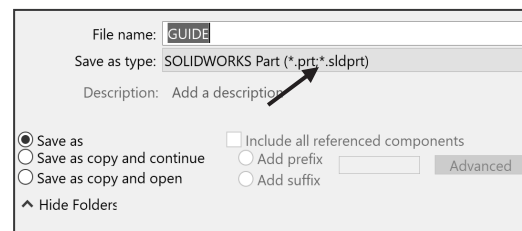

Drawing views can be inserted as follows:

- Utilize the **Model View** tool from the View Layout tab in the CommandManager.
- **Drag and drop** an active part view from the View Palette located in the Task Pane as illustrated. With an open part, drag and drop the selected view into the active drawing sheet.
- **Drag and drop** a part into the drawing to create three Standard Views.
- **Predefine** views in a custom Drawing Template.
- Drag a **hyperlink** through Internet Explorer.



The Top view and Right view are projected off the view you place in the Front view location. Any view can be dragged and dropped into the Front view location of a drawing.

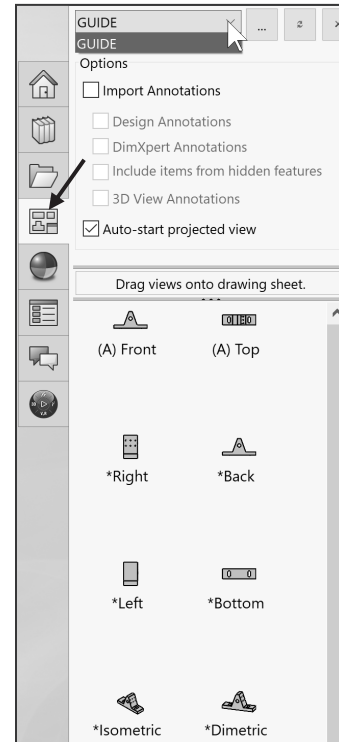

The View Palette from the Task Pane populates when you:

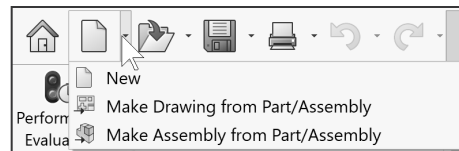

- Click Make Drawing from Part/Assembly.
- Browse to a document from the View Palette.
- Select from a list of open documents in the View Palette.



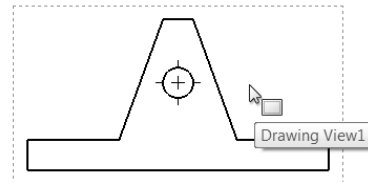

Move Views and Properties of the Sheet

The GUIDE drawing contains four views. Reposition the view on a drawing. Provide approximately 1in. - 2in. (25mm - 50mm) between each view for dimension placement.



Move Views on Sheet1 to create space for additional Drawing View placement. The mouse pointer provides feedback in both the Drawing Sheet  and Drawing View  modes. The mouse pointer displays the Drawing Sheet  icon when the Sheet properties and commands are executed.

The mouse pointer displays the Drawing View  icon when the View properties and commands are executed.

 View the mouse pointer for feedback to select Sheet, View, and Component and Edge properties in the Drawing.

Sheet Properties

- Sheet Properties display properties of the selected sheet.
Right-click in the sheet boundary  to view the available commands.

View Properties

- View Properties display properties of the selected view.
Right-click inside the  view boundary. Modify the View Properties in the Display Style box or the View Toolbar.

Component Properties

- Component Properties display properties of the selected component. Right-click on the face of the component . View the available options.

Edge Properties

- Edge Properties display properties of the selected geometry.
Right-click on an edge  inside the view boundary. View the available options.

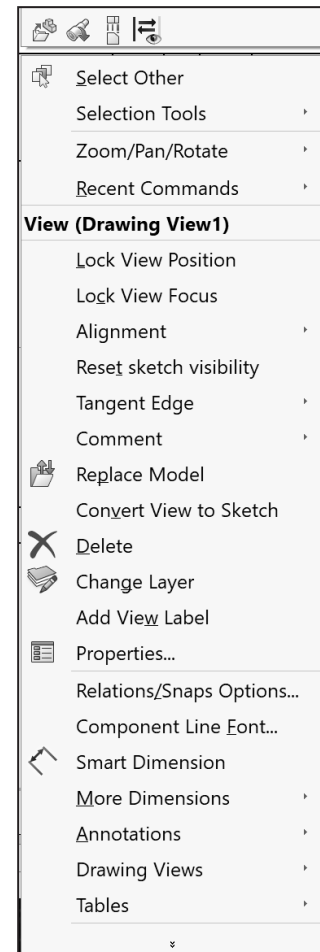
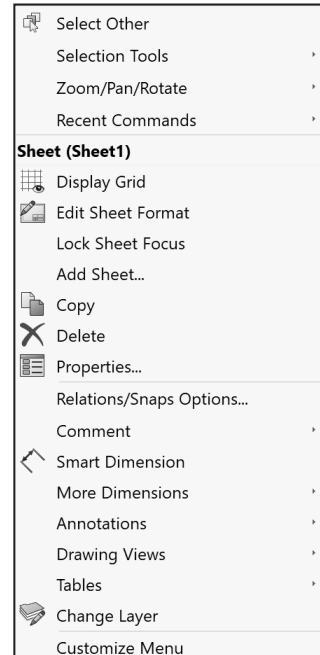
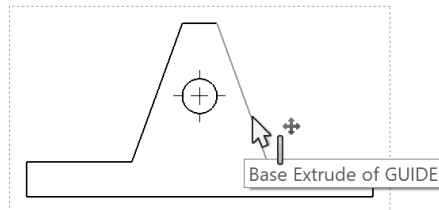

Activity: Move Views and Properties of the Sheet

Modify and move the front view.

- 151) Click inside the **Drawing View1** (Front) view boundary. The mouse pointer displays the Drawing View icon. The view boundary is displayed in blue.

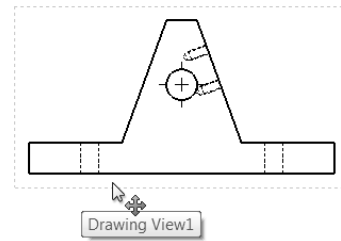

- 152) Click **Hidden Lines Visible** from the Display Style box.
- 153) Position the mouse pointer on the edge of the Front view until the Drawing Move View icon is displayed.

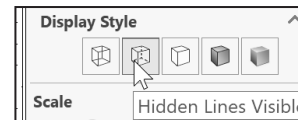

- 154) Click and drag **Drawing View1** in an upward vertical direction. The Top and Right view move aligned to Drawing View1 (Front).

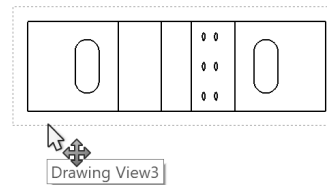

Modify the top view.

- 155) Click inside the **Top view boundary** (Drawing View3). The Drawing View3 PropertyManager is displayed.

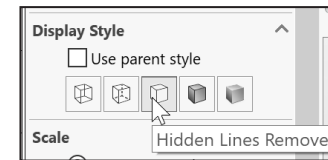

- 156) Click **Hidden Lines Removed** from the Display Style box. Various display styles provide the ability to select and view features of a part.

- 157) Click **OK** from the Drawing View3 PropertyManager. Later, address Centerlines, Center Marks, Tangent Edges Removed, Display styles, Customer properties, etc. to finish the drawing.

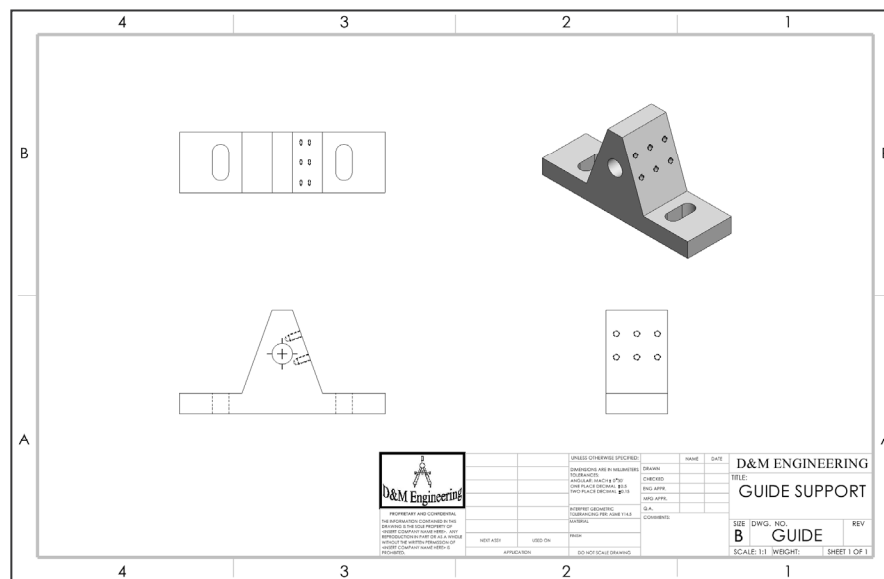

 Select the dashed view boundary to move a view in the drawing.

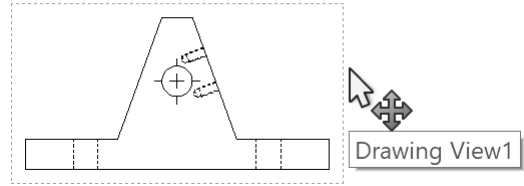

Auxiliary View, Section View, and Detail View

The GUIDE drawing requires additional views to document the part. Insert an Auxiliary view, Section view and Detail view from the View Layout tab in the CommandManager. Review the following view terminology before you begin the next activity.

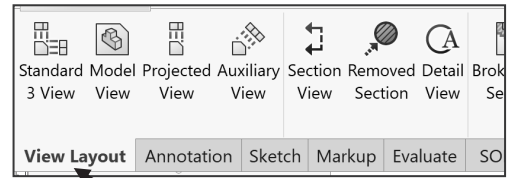

Auxiliary View:

The Auxiliary view  drawing tool provides the ability to display a plane parallel to an angled plane with true dimensions.

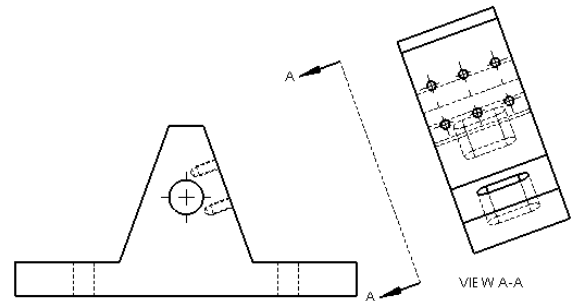

A primary Auxiliary view is hinged to one of the six Principle Orthographic views. Create a Primary Auxiliary view that references the angled edge in the Front view.

Section View:

The Section view  drawing tool provides the ability to display the interior features of a part. Define a cutting plane with a sketched line in a view perpendicular to the Section view.

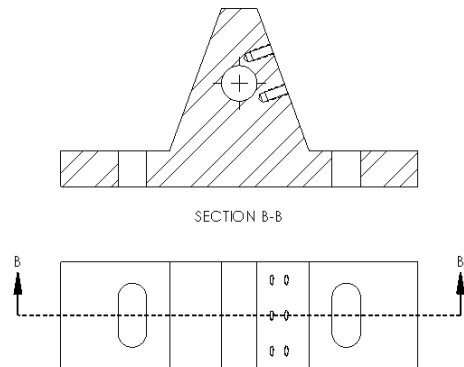



Use the Section view sketch mode in conjunction with the Section tool user interface to create a Section view in the Top view.

Detail View:

The Detail view  drawing tool provides the ability to enlarge an area of an existing view. Specify location, shape and scale.

Create a Detail view from a Section view with a 3:2 scale.

 The book is designed to expose the new user to many tools, techniques and procedures. It does not always use the most direct tool or process.

 You can add multiple breaks to models using the Model Break View tool. The model breaks are saved as configurations. Model break views are helpful when you need to shorten components especially for technical and marketing purposes. Additionally, the Model Break View tool lets you display breaks on drawing views per ASME Y14.3.

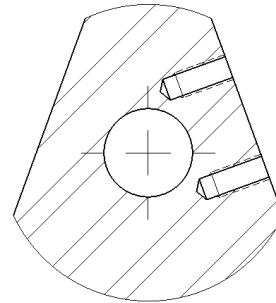

DETAIL C
SCALE 3 : 2

Activity: Auxiliary Drawing View

Insert an Auxiliary drawing view.

158) Click the **View Layout** tab from the CommandManager.

159) Click the **Auxiliary View**  drawing tool. The Auxiliary View PropertyManager is displayed.

160) Click the **right angled edge** of the **GUIDE** in the Front view as illustrated.

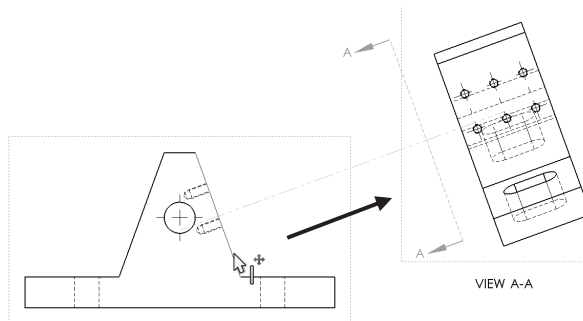

161) Click a **position** to the right and up from the Front view as illustrated.

Position the Auxiliary View.

162) Click and drag the **section line A-A midpoint** toward Drawing View1. The default label A is displayed in the Arrow box.

163) Click the **OK**  from the PropertyManager.

Rename the new view.

164) **Rename** the new view (Drawing View#) to Auxiliary in the FeatureManager as illustrated.

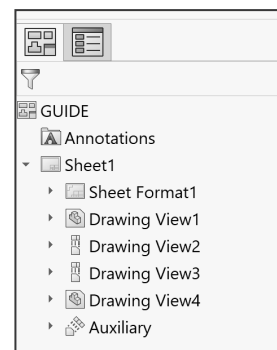

Activity: Section Drawing View

Insert a Section drawing view.

165) Click the **Section View**  drawing tool. The Section View PropertyManager is displayed. The Section tab is selected by default.

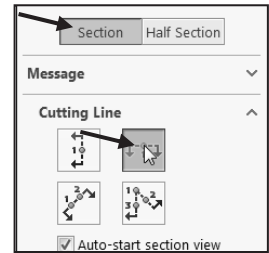

166) Click the **Horizontal** Cutting Line button as illustrated.

167) Locate the **midpoint of the left vertical line** as illustrated.

168) Click the **midpoint**. Note: Your options with the Pop-up menu.

169) Click the **OK**  icon from the pop-up menu.

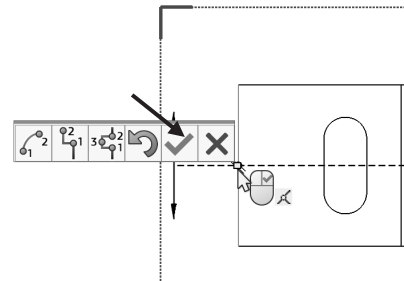

Position the Section drawing View.

170) Click a **position** above the Top view. The section arrows point downward.

171) If needed, check **Flip direction** from the Section Line box. The section arrows point upward. If required, enter **B** for Section View Name in the Label box.

172) Click **OK**  from the Section View B-B PropertyManager. Section View B-B is displayed in the FeatureManager. If required, hide any annotations.

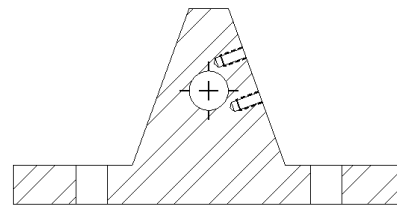

173) If needed, insert a **CenterMark** in the Section view. Utilize the CenterMark tool under the Annotations tab.

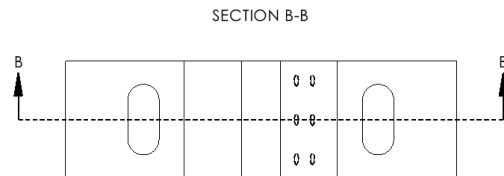

Save the drawing.

174) Click **Save** .

 The material in the **GUIDE** part determines the hatch pattern in the **GUIDE** drawing.

Activity: Detail Drawing View

Insert a Detail drawing view.

175) Click the **Detail View**  drawing tool. The Detail View PropertyManager is displayed.

Sketch a Detail circle.

176) Click the **center point** of the Guide Hole in the Section view.

177) Click a **position** to the lower left of the Guide Hole to complete the circle.

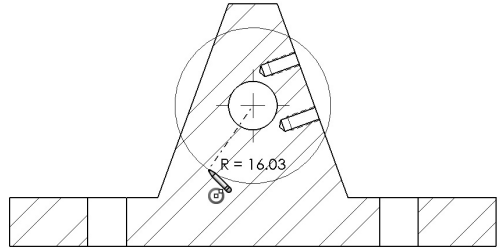

SECTION B-B

Position the Detail View.

178) Click a **position** to the right of the Section View. If required, enter **C** for Detail View Name in the Label box.

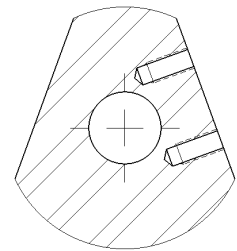
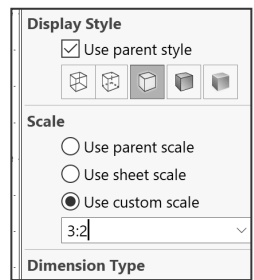

DETAIL C
SCALE 3 : 2

Modify the drawing view scale.

179) Check **Use custom scale** option.

180) Enter **3:2** in the Scale box. Click **OK**  from the Detail View C PropertyManager. Detail View C is displayed in the FeatureManager. Note: If needed, insert a CenterMark in the Detail view. Utilize the CenterMark tool under the Annotations tab.

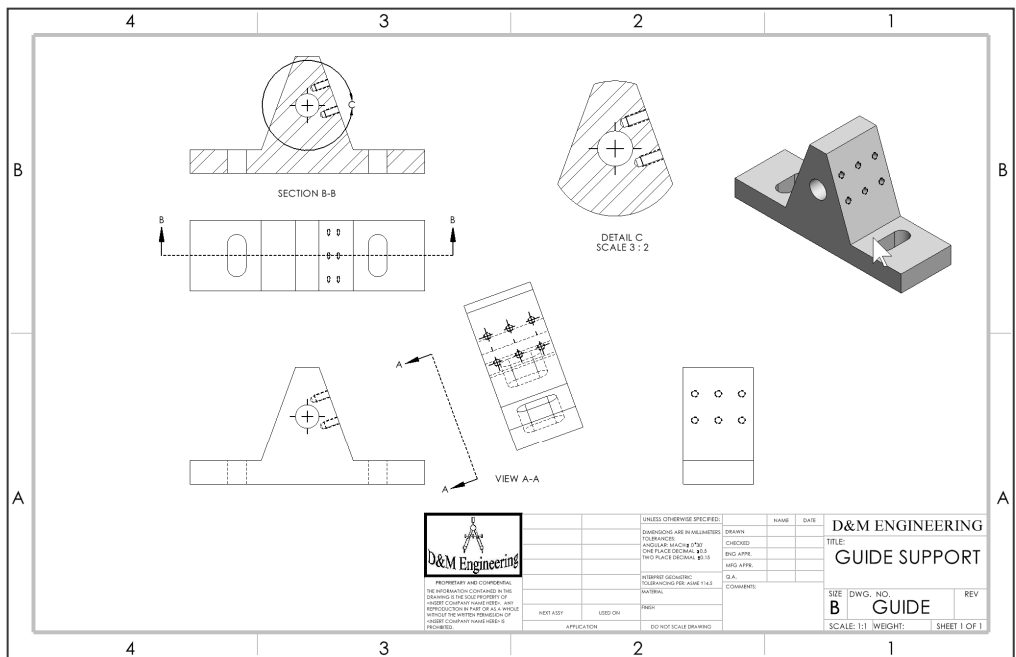

Save the GUIDE drawing.

181) Click **Save** .

Partial Auxiliary Drawing View - Crop Drawing View

Create a Partial Auxiliary view from the Full Auxiliary view. Sketch a closed profile in the active Auxiliary view. Create the Profile with a closed Spline. Create a Partial Auxiliary view.

Crop the view. The 6mm dimension references the centerline from the Guide Hole. For Quality Assurance and Inspection of the GUIDE part, add a dimension that references the Temporary Axis of the Guide Hole. Sketch a centerline collinear with the Temporary Axis.

Activity: Partial Auxiliary Drawing View - Crop Drawing View

Select the view.

182) Click **Zoom to Area**  from the Heads-up View toolbar.

183) **Zoom in** on the Auxiliary view.

184) Click **Zoom to Area**  to deactivate.

185) Click inside the **Auxiliary view boundary**. The Auxiliary PropertyManager is displayed.

Display Hidden Lines Removed.

186) Click **Hidden Lines Removed** .

Sketch a closed Spline profile.

187) Click the **Sketch** tab from the CommandManager.

188) Click the **Spline**  Sketch tool.

189) Click **five or more positions** clockwise to create the closed Spline as illustrated. The first point is Coincident with the last point. The Sketch profile is closed.

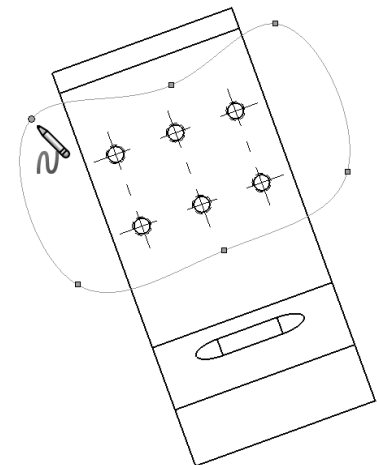

VIEW A-A

Insert a Partial Auxiliary Drawing View.

190) Click the **Crop View**  drawing tool from the View Layout tab in the CommandManager.

191) Click **OK**  from the Spline PropertyManager. The Crop View is displayed on Sheet1.

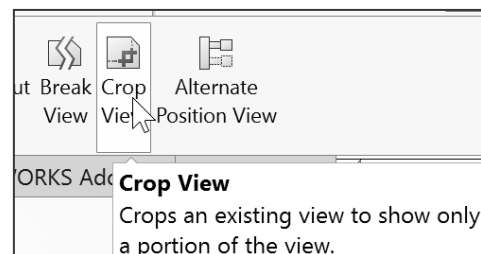

Display the Temporary Axes and insert a sketched centerline.

192) Click inside the **Auxiliary view boundary**. The Auxiliary PropertyManager is displayed.

193) Click **View, Hide/Show**, check **Temporary Axes** from the Menu bar. The Temporary Axis for the Guide Hole is displayed.

194) Click **Sketch** tab from the CommandManager.

195) Click the **Centerline**  Sketch tool. The Insert Line PropertyManager is displayed.

196) Sketch a **centerline** parallel above the Temporary axis. The centerline extends approximately 5mm to the left and right of the profile lines. If needed insert a Parallel relation to the temporary axis.

197) Right-click **Select** to deselect the Centerline Sketch tool.

Add a Collinear relation between the centerline and temporary axis.

198) Click the **centerline**. The Line Properties PropertyManager is displayed.

199) Hold the **Ctrl** key down.

200) Click the **Temporary Axis**. The mouse pointer displays the Axis feedback  icon. The Properties PropertyManager is displayed. Axis<1> and Line1 are displayed in the Selected Entities box.

201) Release the **Ctrl** key.

202) Click **Collinear** from the Add Relations box.

203) Click **OK**  from the Properties PropertyManager.

Hide the Temporary Axis.

204) Click **View, Hide/Show**, uncheck **Temporary Axes** from the Menu bar.

Move the views to allow for ample spacing for dimensions and notes.

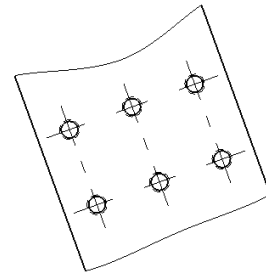

VIEW A-A

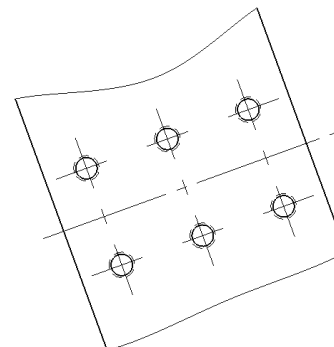
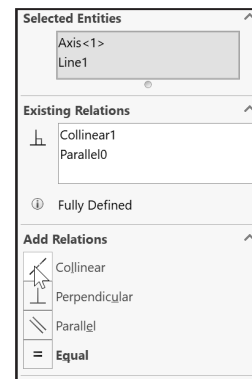
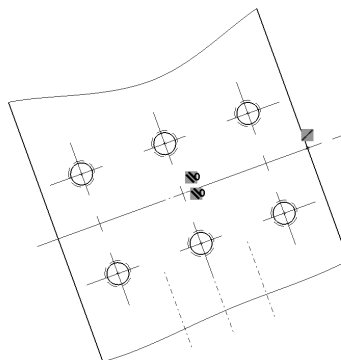
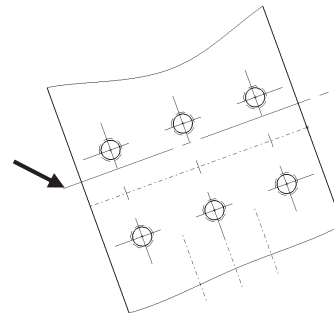

VIEW A-A



Review the GUIDE Drawing

You created a new drawing, GUIDE with the B-ANSI-MM Drawing Template. The GUIDE drawing utilized the GUIDE part in the Model View PropertyManager. The Model View PropertyManager allowed new views to be inserted with a View Orientation. You selected Front, Top, Right and Isometric to position the GUIDE views.

Additional views were required to fully detail the GUIDE. You inserted the Auxiliary Section, Detail, Partial Auxiliary and Crop view. You moved the views by dragging the view boundary. The next step is to insert the dimensions and annotations to detail the GUIDE drawing.

Display Modes and Performance

Display modes for a Drawing view are similar to a part. When applying Shaded With Edges, select either Tangent edges removed or Tangent edges As phantom from the System Options section.



Mechanical details require either the Hidden Lines Visible mode or the Hidden Lines Removed display mode. Select Shaded/Hidden Lines Removed to display Auxiliary views to avoid confusion.

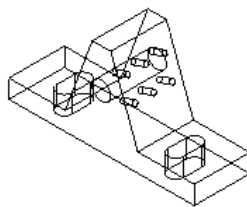
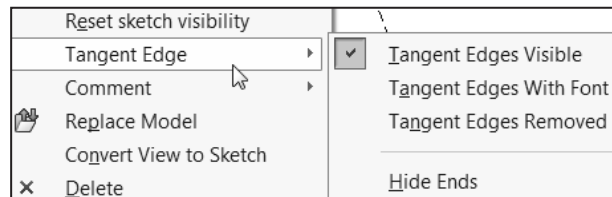

Wireframe

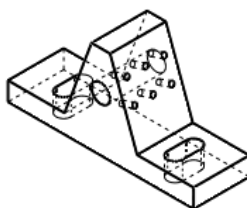

Hidden Line Visible

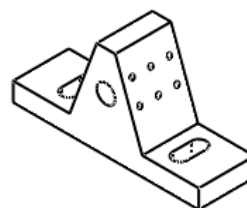

Hidden Line Removed

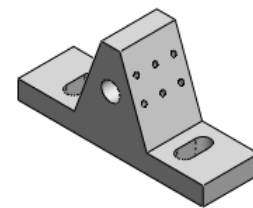

Shaded With Edges

Tangent Edges Visible provides clarity for feature edges. To address the ASME Y14.5 standard, use Tangent Edges With Font (Phantom lines) or Tangent Edges Removed. Right-click in the view boundary to access the Tangent Edge options.

Drawing views can be displayed in High quality and Draft quality. In High quality, all model information is loaded into memory. By default, drawing views are displayed in High quality.

In Draft quality, only minimum model information is loaded into memory. Utilize Draft quality for large assemblies to increase performance.

 Utilize **Options**, **System Options**, **Drawings**, **Display Style** to control the quality of a view.

By default, SOLIDWORKS will populate Section and Detail views before other views on your drawing.

Use the Pack and Go tool to save and gather all related files for a model design (parts, assemblies, drawings, references, design tables, Design Binder content, decals, appearances, and scenes, and SOLIDWORKS Simulation results) into a single folder or zip file. It's one of the best tools to utilize when you are trying to save a large assembly or drawing with references and SOLIDWORKS Toolbox components.

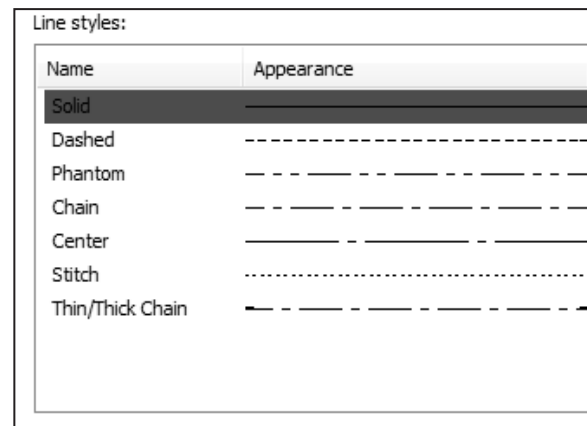
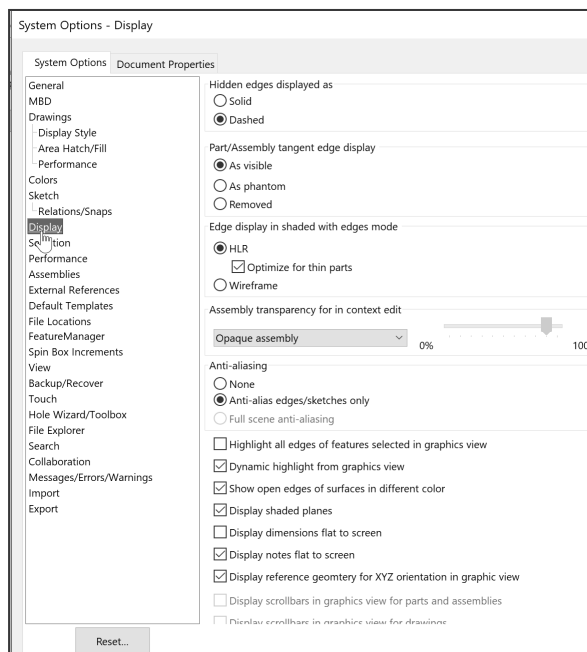
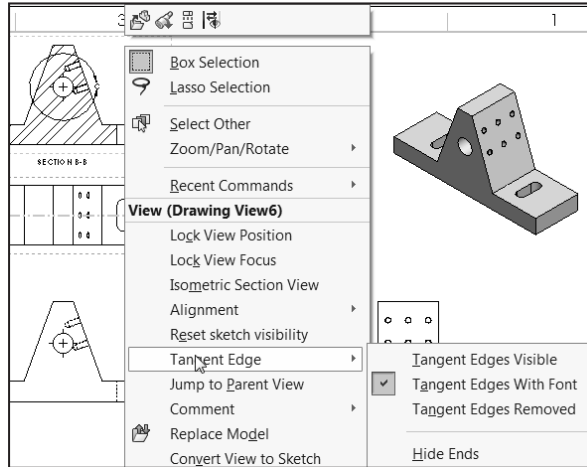

Detail Drawing

The design intent of this project is to work with dimensions inserted from parts and to incorporate them into the drawings. Explore methods to move, hide and recreate dimensions to adhere to a drawing standard.

There are other solutions to the dimensioning schemes illustrated in this project. Detail drawings require dimensions, annotations, tolerance, materials, Engineering Change Orders, authorization, etc. to release the part to manufacturing and other notes prior to production.

Review a hypothetical “worst case” drawing situation. You just inserted dimensions from a part into a drawing. The dimensions, extension lines and arrows are not in the correct locations. How can you address the position of these details? Answer: Dimension to an ASME Y14.5M standard.

No.	Situation:
1	Extension line crosses dimension line. Dimensions not evenly spaced.
2	Largest dimension placed closest to profile.
3	Leader lines overlapping.
4	Extension line crossing arrowhead.
5	Arrow gap too large.
6	Dimension pointing to feature in another view. Missing dimension – inserted into Detail view (not shown).
7	Dimension text over centerline, too close to profile.
8	Dimension from other view – leader line too long.
9	Dimension inside section lines.
10	No visible gap.
11	Arrows overlapping text.
12	Incorrect decimal display with whole number (millimeter), no specified tolerance.

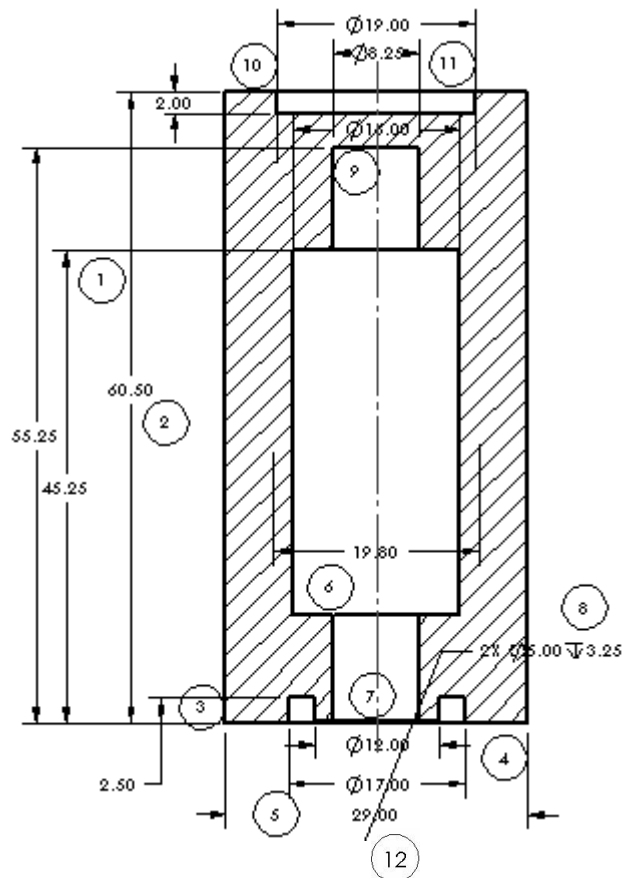

Worst Case Drawing Situation

The ASME Y14.5 2009 standard defines an engineering drawing standard. Review the twelve changes made to the drawing to meet the standard.

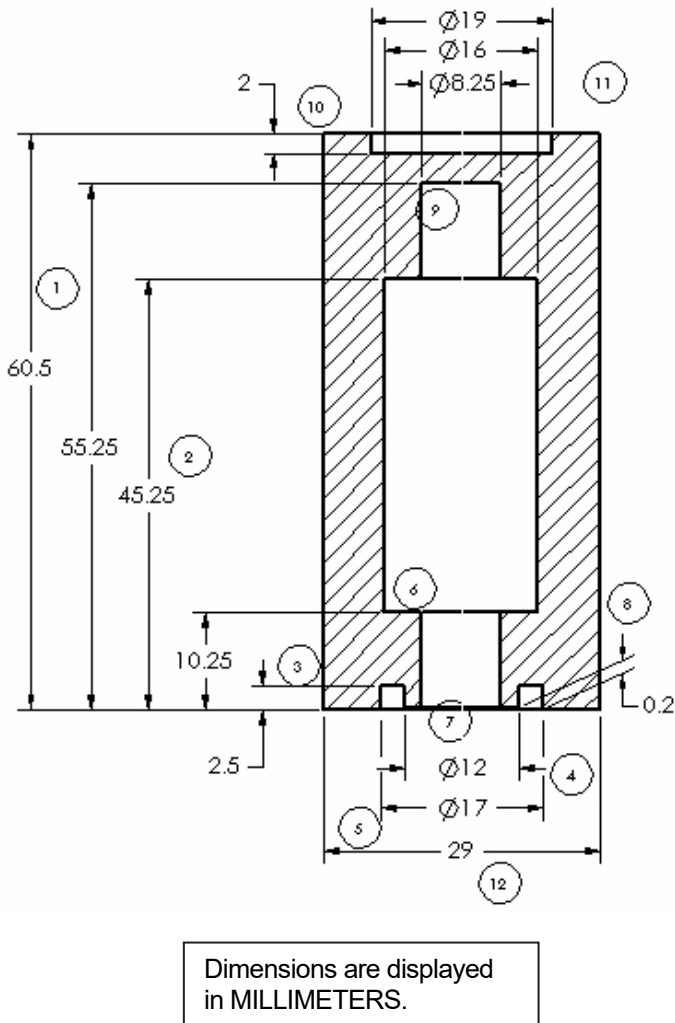

No.	Preferred Application of the Dimensions:
1	Extension lines do not cross unless situation is unavoidable. Stagger dimension text.
2	Largest dimension placed farthest from profile. Dimensions are evenly spaced and grouped.
3	Arrowheads do not overlap.
4	Break extension lines that cross close to arrowhead.
5	Flip arrows to the inside.
6	Move dimensions to the view that displays the outline of the feature. Ensure that all dimensions are accounted for.
7	Move text off of reference geometry (centerline).
8	Drag dimensions into their correct view boundary. Create reference dimensions if required. Slant extension lines to clearly illustrate feature.
9	Locate dimensions outside off section lines.
10	Create a visible gap between extension lines and profile lines.
11	Arrows do not overlap the text.
12	Whole numbers displayed with no zero and no decimal point (millimeter).

Apply these dimension practices to the GUIDE drawing. Manufacturing utilizes detailed drawings. A mistake on a drawing can cost your company a substantial loss in revenue. The mistake could result in a customer liability lawsuit.

As the designer, dimension and annotate your parts clearly to avoid common problems and mistakes.

Insert Dimensions from the part.
Dimensions you created for each part feature are inserted into the drawing.

Select the first dimensions to display for the Front view. Do not select the Import Items into all Views option for complex drawings. Dimension text is cluttered and difficult to locate.

Follow a systematic, “one view at a time” approach for complex drawings. Insert part feature dimensions onto the Dim Layer for this project.

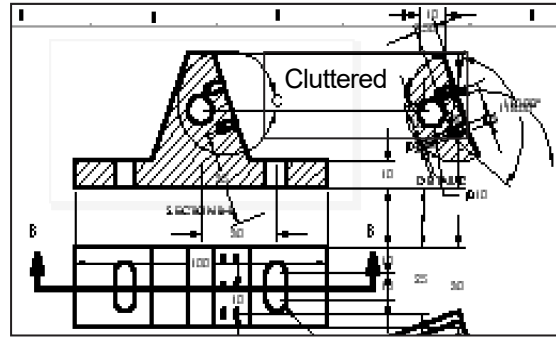

Activity: Detail Drawing - Insert Model Items

Set the Dimension Layer.

205) Right-click in the drawing sheet.

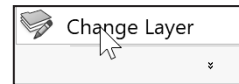

206) Click Change Layer. The Change Layer dialog box is displayed.

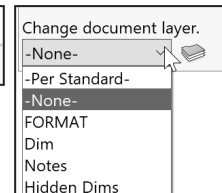

207) Select Dim from the drop-down menu.

Insert dimensions into Drawing View1 (Front).

208) Click inside the **Drawing View1** boundary. The Drawing View1 PropertyManager is displayed.

209) Click the **Model Items** tool from the Annotation tab in the CommandManager. The Model Items PropertyManager is displayed.

210) Select Entire model from the Source box. Drawing View1 is displayed in the Destination box. At this time, do not click the Hole Wizard information into the drawing. Accept the default settings as illustrated.

211) Click OK from the Model Items PropertyManager. Dimensions are displayed in the Front view.

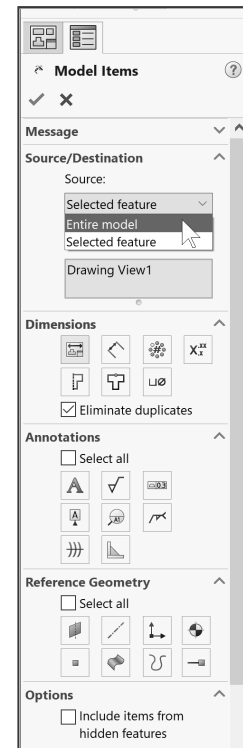

 In SOLIDWORKS, inserted dimensions in the drawing are displayed in gray. Imported dimensions from the part are displayed in black.

Drawing dimension location is dependent on:

- Feature dimension creation.
- Selected drawing views.

Note: The Import items into all views option, first inserts dimensions into Section Views and Detail Views. The remaining dimensions are distributed among the visible views on the drawing.

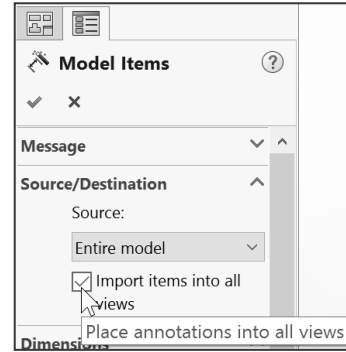

Move Dimensions in the Same View

Move dimensions within the same view. Use the mouse pointer to drag dimensions and leader lines to a new location.

Leader lines reference the size of the profile. A gap must exist between the profile lines and the leader lines. Shorten the leader lines to maintain a drawing standard. Use the blue Arrow control buttons to flip the dimension arrows.

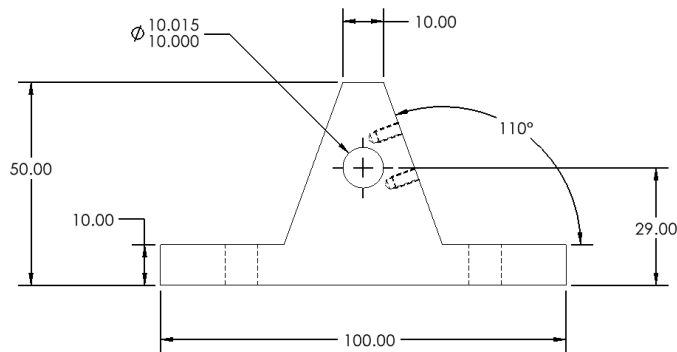

Insert part dimensions into the Top view. The Top view displays crowded dimensions. Move the overall dimensions. Move the Slot Cut dimensions.

Place dimensions in the view where they display the most detail. Move dimensions to the Auxiliary View. Hide the diameter dimensions and add Hole Callouts. Display the view with Hidden Lines Removed.

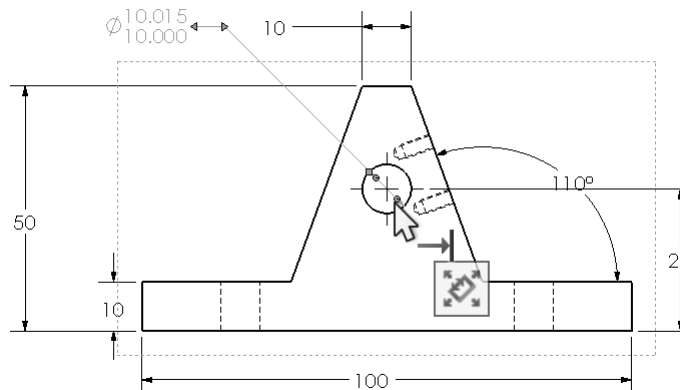

Illustrations may vary depending on your SOLIDWORKS release version.

Activity: Detail Drawing – Modify Linear Precision. Move Dimensions.

Modify linear precision. Move the linear dimensions in Drawing View1.

212) Modify linear precision to zero in the Drawing document.

213) Zoom to area  on Drawing View1.

214) Click and drag the vertical dimension text **10**, **29**, and **50** to the right as illustrated.

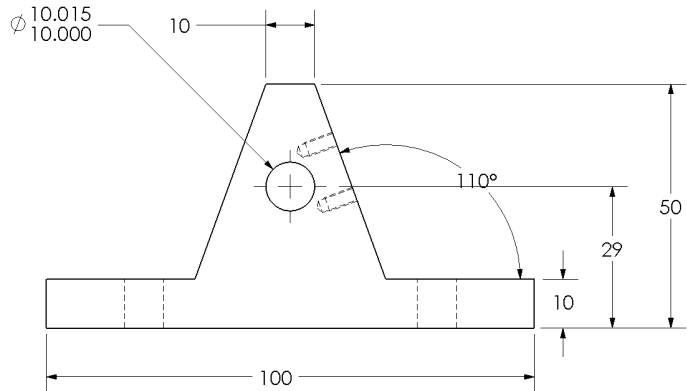

Create a gap between the extension lines and the profile lines for the 10mm vertical dimension.

215) Click the vertical dimension text **10**. The vertical dimension text, extension lines and the profile lines are displayed in blue.

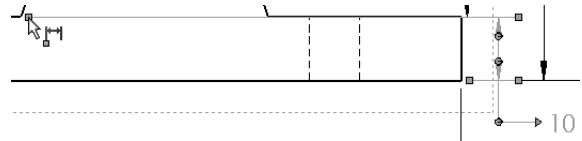

216) Click and drag the **square blue endpoints** approximately 10mms from the right vertex as illustrated. A gap is created between the extension line and the profile.

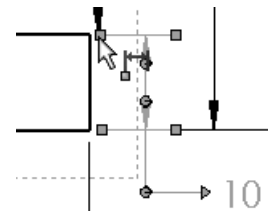

A gap exists between the profile line and the leader lines. Drag the blue endpoints to a vertex, to create a gap.

 The smallest linear dimension should be placed closest to the profile.

 Note the default settings for a drawing document under Dimensions. Trailing zeroes Dimensions default: **Standard**. Trailing zeroes Tolerances default: **Show**. Trailing zeroes Properties default: **Show**.

Fit the drawing to the Graphics window.

217) Press the **f** key.

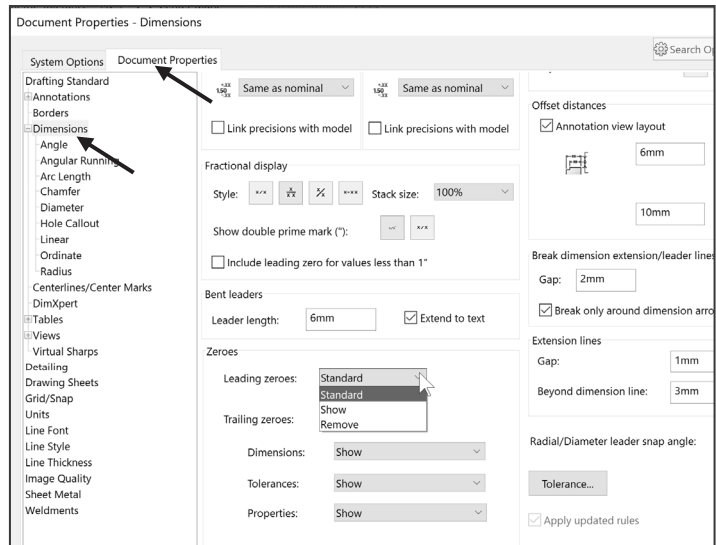

Insert dimensions into Drawing View3.

218) Click inside the **Drawing View3** boundary. The Drawing View3 PropertyManager is displayed.

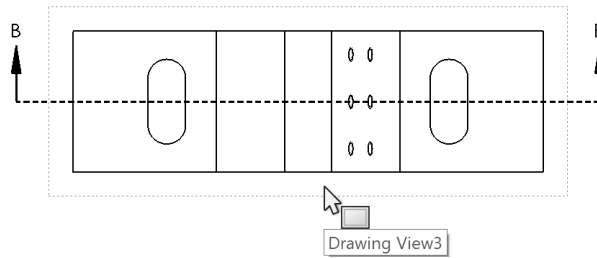

219) Click **Hidden Lines Removed**.

220) Click the **Model Items** tool from the Annotation tab in the CommandManager. The Model Items PropertyManager is displayed.

221) Select **Entire model** from the Source box. Drawing View3 is displayed in the Destination box. Accept the default settings.

222) Click **OK** from the Model Items PropertyManager.

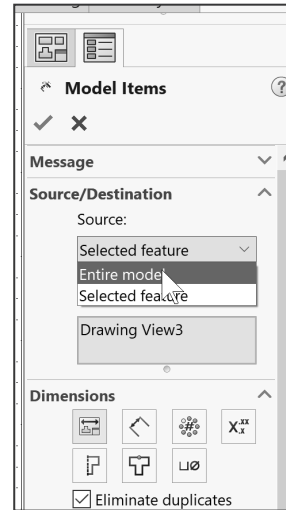

Move the vertical dimensions.

223) Click and drag the two vertical Slot Cut dimensions, **10** to the right of the Section arrow as illustrated.

224) Flip the **arrows** to the inside.

225) Click the **dimension text** and drag the text outside the leader lines. Hide all other dimensions and annotations as illustrated.

226) If needed, enter **2X** for the Radius as illustrated.

Fit the drawing to the Graphics window.

227) Press the **f** key.

Save the GUIDE drawing.

228) Click **Save**.

