

The Complete Guide to **Mold Making with SOLIDWORKS® 2022**

Basic through Advanced Techniques

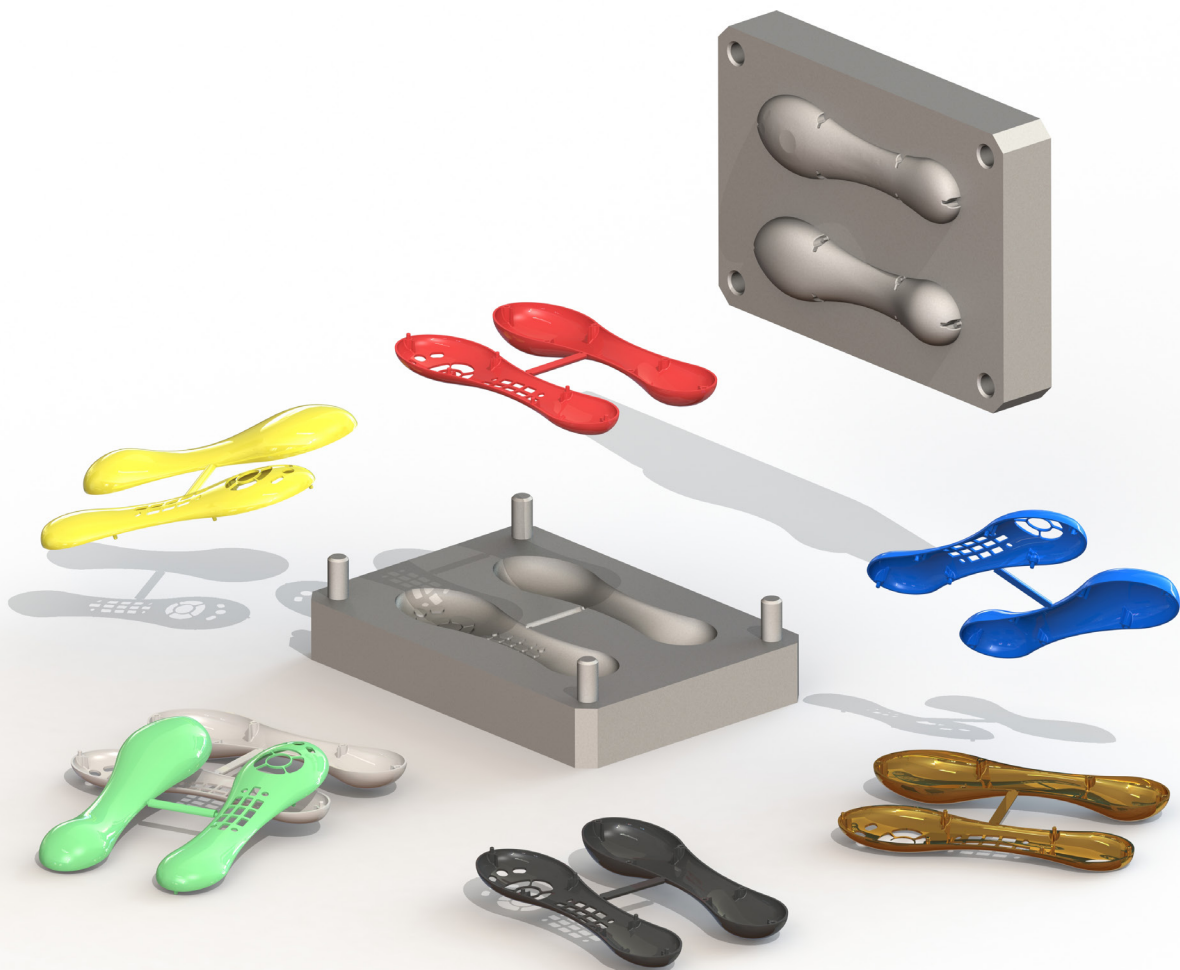

Paul Tran CSWE, CSWI

Visit the following websites to learn more about this book:



[amazon.com](https://www.amazon.com)

[Google books](https://books.google.com)

[BARNES & NOBLE](https://www.barnesandnoble.com)

CHAPTER 2

Surface Repair

A lot of times, import files such as Parasolid, STEP, IGES, ACIS, and others may fail to produce solid or surface geometry because not all CAD systems support the same features, tolerances, or simply there are gaps and overlaps existing in the model.

This lesson will teach us some of the methods to repair the errors found in a surface model as well as converting it into a solid part.

1. Opening a Parasolid document:

Select **File, Open**.

Open a Parasolid document named: **Mouse.x_b**



2. Running Import Diagnostics:

The Import Diagnostics dialog appears when a non-SOLIDWORKS native document is opened.

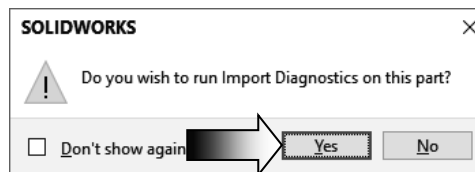

Import diagnostics repairs faulty surfaces, heals gaps between surfaces, knits repaired surfaces into closed bodies.
(Note: 3D Interconnect should be disabled for this lesson).

Click **YES** to run the Import Diagnostics utility.

There are **4 gaps** found in the model. They are displayed under the Gap Between Faces section.

Click **Attempt to Heal All** (arrow).

Both options Heal Gaps and Remove Gaps do not produce the desired results. We will repair the gaps and overlaps manually instead.

Click **Cancel**

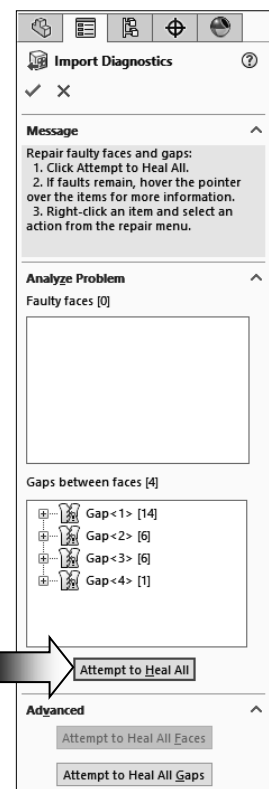

3. Examining the small surfaces:

There are small slivers existing in the model. Zoom in on the t-shaped slot on top of the surface model.

There is a small triangular surface and a rectangular cutout in this area.

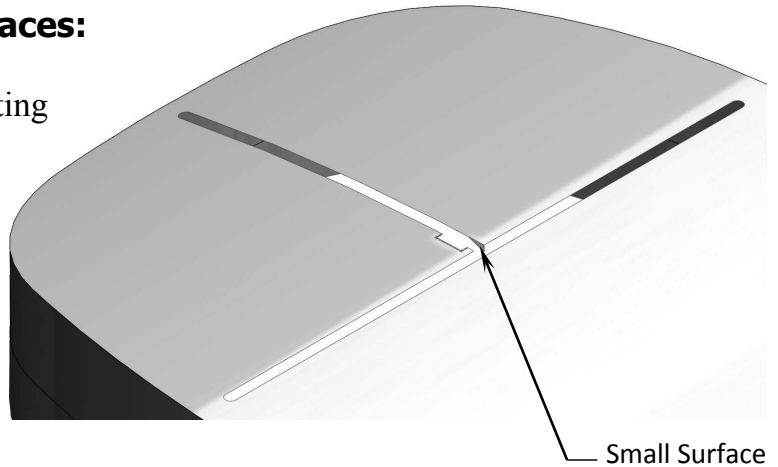

On the left side of the model, there is a gap and a small triangular surface in this area.

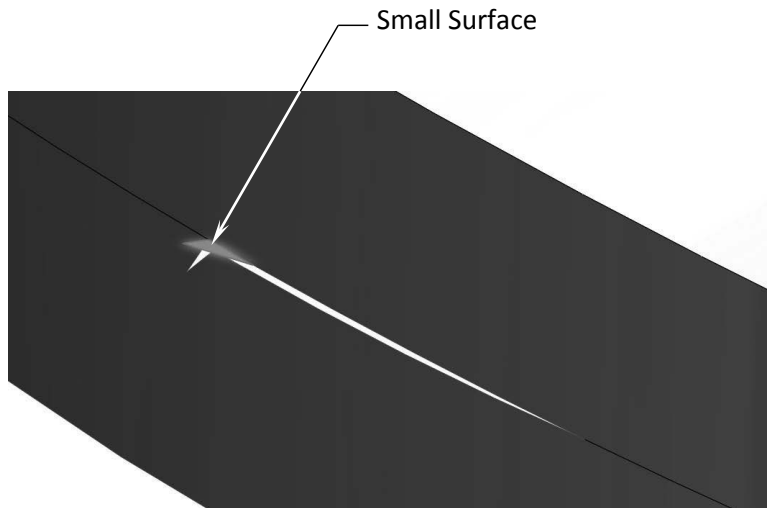

On the right end of the model, there is also a small triangular surface that did not get trimmed correctly.

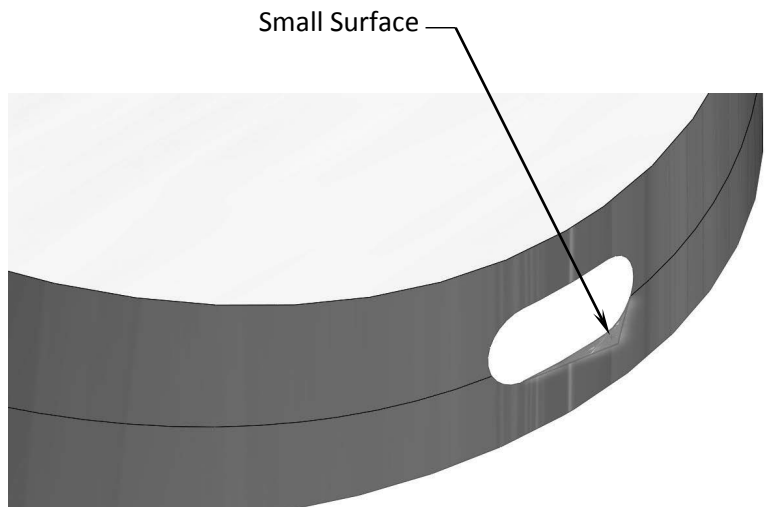

4. Deleting surfaces:

First, we will delete the 3 small triangular surfaces.

Change to the Surfaces tab and click **Delete Face** (arrow).

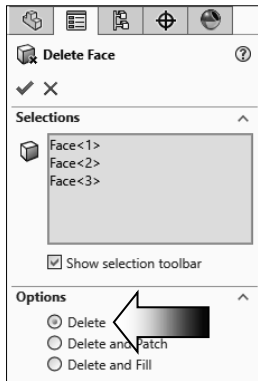
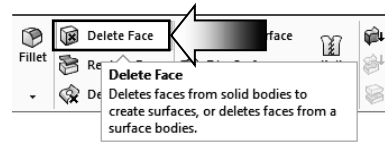

Select the **3 small triangular surfaces** as noted.

Under Options, select: **Delete**.

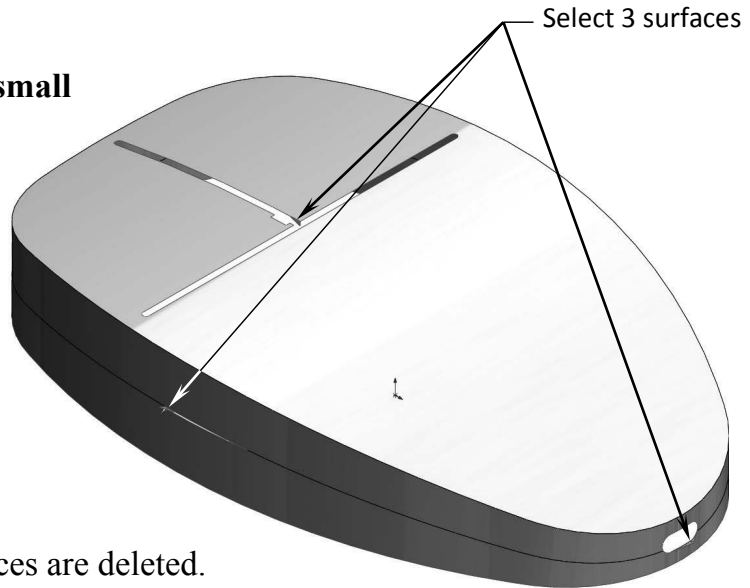

Click **OK**. The selected surfaces are deleted.

5. Deleting hole:

Next, we will delete the t-shaped lot on the top of the surface model.

Click **Delete Hole** on the Surfaces tab (arrow).

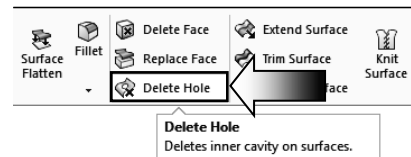

Under Selections, select the **13 edges** as indicated.

(Right-click an edge and pick: **Select-Tangency** would be a little quicker.)

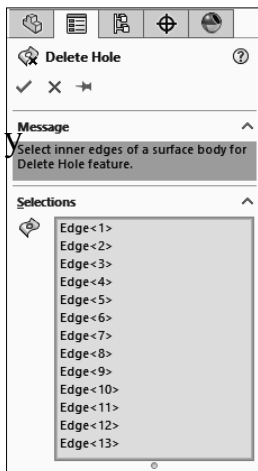

Click **OK**.

The opening is removed and the surface is healed.

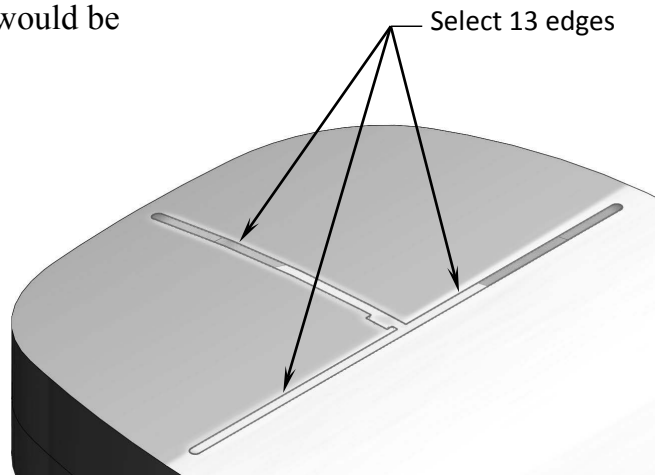

6. Patching the openings:

Zoom in on the gap on the left side of the surface model.

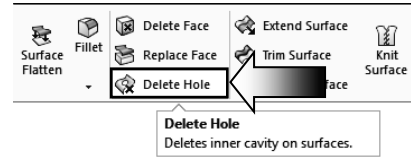

Click **Delete Hole** (arrow).

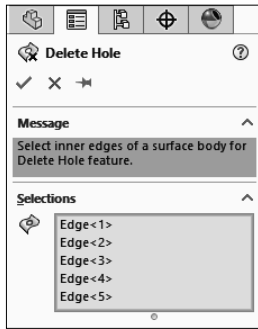

Select the **5 edges** of the opening.

Click **OK**.

The gap is healed.

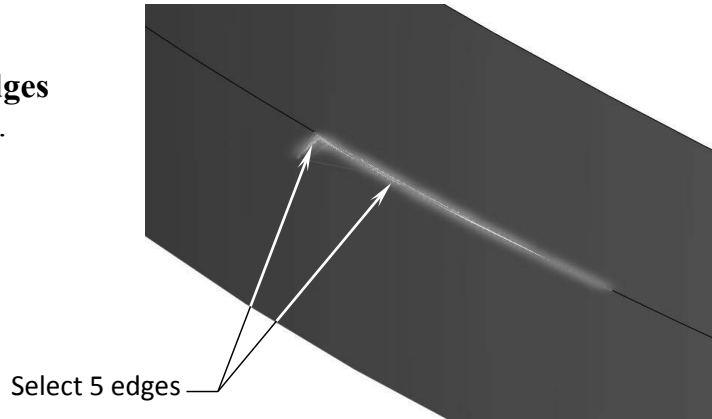

Zoom in on the right end of the model.

Click **Delete Hole** again.

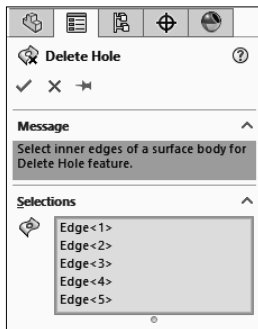

Select the **5 edges** of the elliptical opening as noted.

Click **OK**.

The opening is removed.

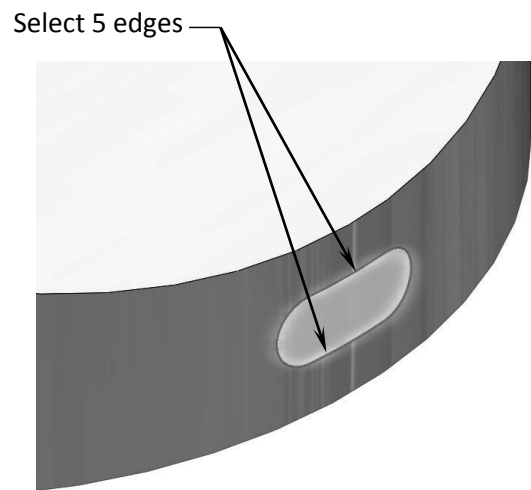

The gaps and openings are removed from the surface model.

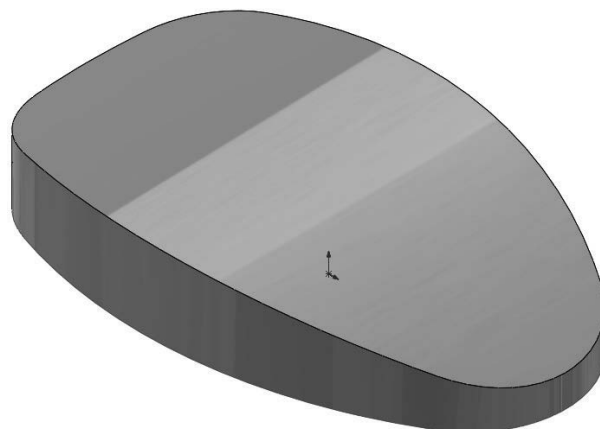

7. Adding draft:

A plastic injection molded part must have adequate drafts applied to all surfaces so that it can be ejected from the mold easily.

The surfaces on the sides of this surface model do not have any drafts at this point. We will add a 3 degrees draft to those surfaces now.

Change to the **Mold Tools** tab.

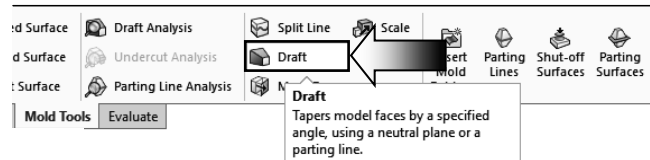

Click **Draft** (arrow).

For Type of Draft, select: **Neutral Plane**.

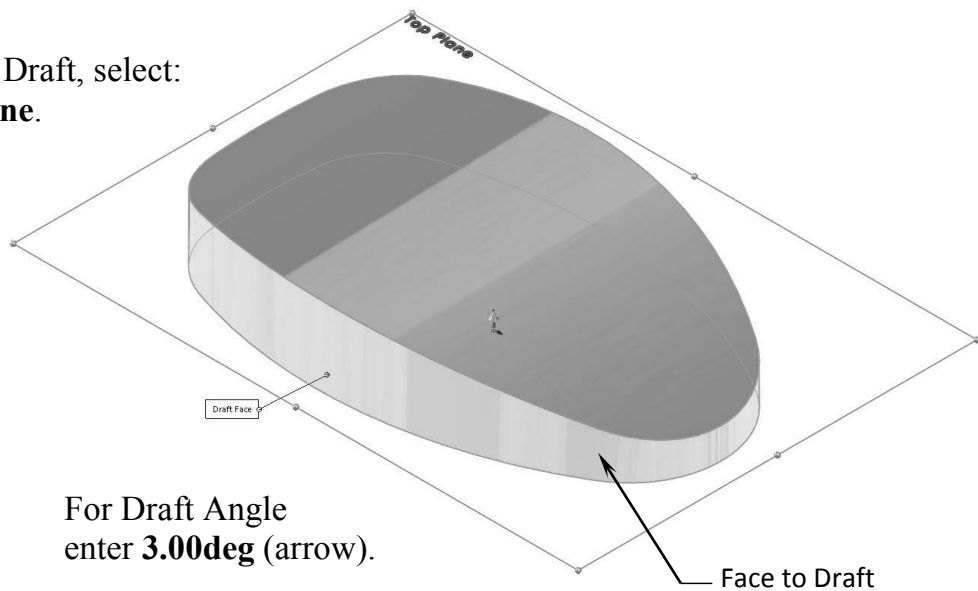
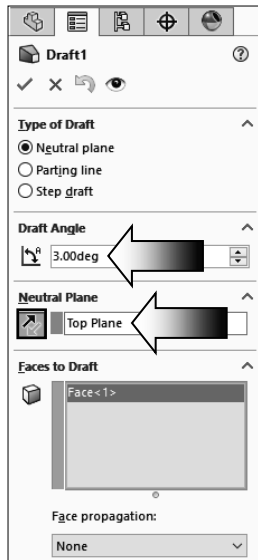

For Draft Angle enter **3.00deg** (arrow).

For Neutral Plane, select the **Top** plane from the Feature tree.

For Faces to Draft, select the **side-face** as indicated.

Click **OK**.

Change to the Front orientation to view the draft angle on the side of the model.

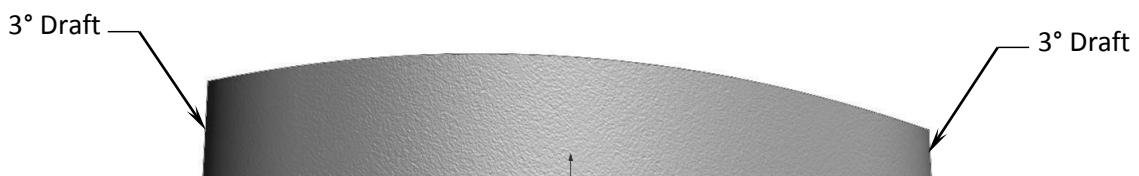

8. Creating a split line feature:

The Split Line tool splits a surface into 2 surfaces so that each surface can be worked on individually.

Select the **Front** plane and open a new sketch.

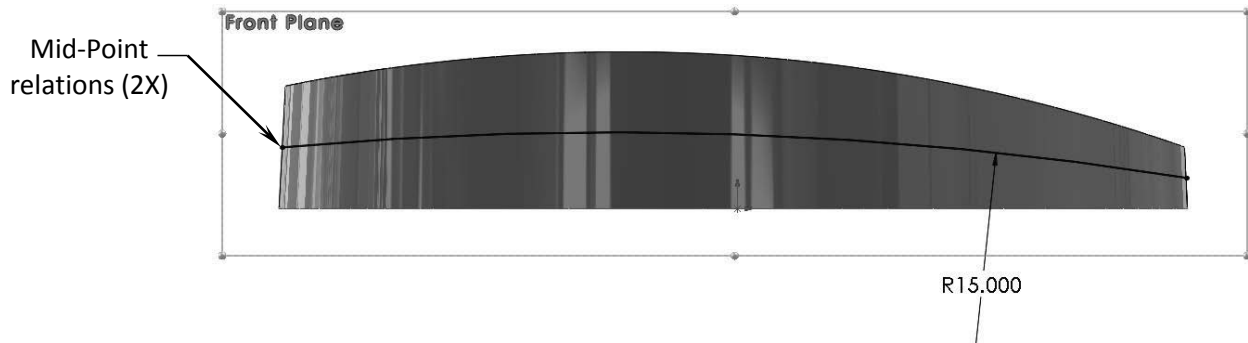

Sketch a **3-Point-Arc** and add the **Mid-Point** relations as indicated.

Add the **R15.000** dimension to fully define the sketch.

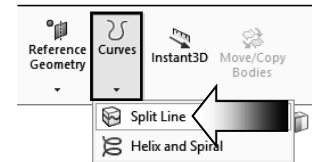

Change to the **Surfaces** tab and select: **Curves, Split Line** (arrow).

Use the default **Projection** type.

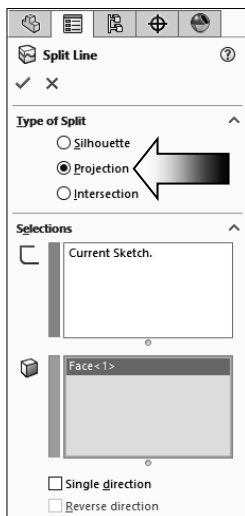

The **Current-Sketch** is selected automatically as the Split Sketch.

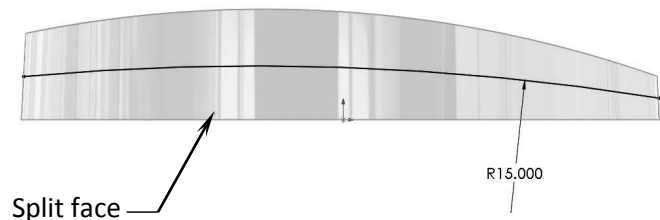

For Split Face, select the **side-face** of the model as indicated.

Click **OK**.

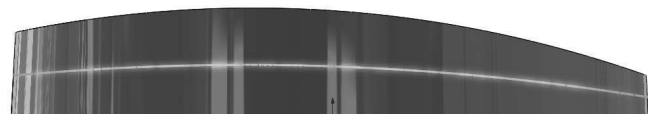

9. Creating a face fillet:

The Split Line created in the last step will be used as a boundary (or Hold Line) to determine the face fillet shape. The radius of the fillet is driven by the distance between the hold line and the edge to fillet.

Click **Fillet**.

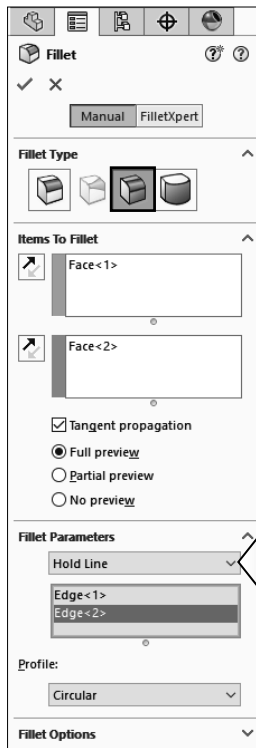

For Fillet Type, select **Face Fillet**.

For Face Set 1, select the **top face**.

Select 2 edges for Hold Line

For Face Set 2, select the **side-face** as noted.

For Fillet Parameters, select **Hold Line** from the drop-down list.

For Hold Line, select the **2 edges** of the split line.

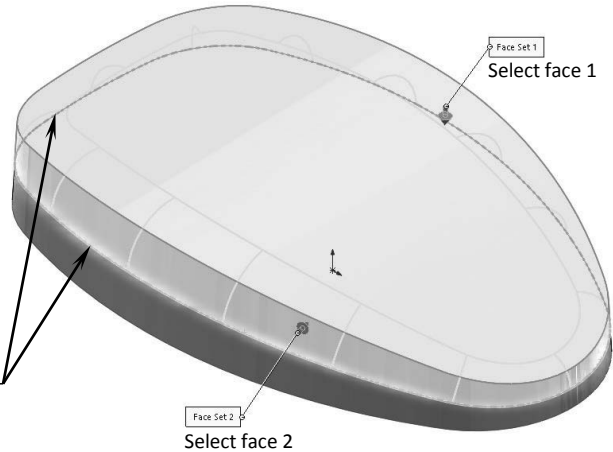

Leave all other parameters at their defaults.

Click **OK**.

The fillet shape and size were determined by the hold line (or the boundary of the split line). The fillet on the right end is smaller than the one on the left.



10. Adding thickness:

The surface model can now be thickened into a solid model so that other features can be added to it.

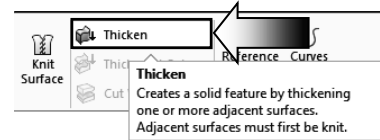

To rotate the model to the same orientation as the one shown below, click the following:

- * **Control + 7 = Isometric View**, and then:
- * **Shift + Up Arrow Key Twice = Reverse Isometric View**.

Click **Thicken** (arrow) on the Surfaces tab.

For Thicken Parameter, select the **Surface Model**.

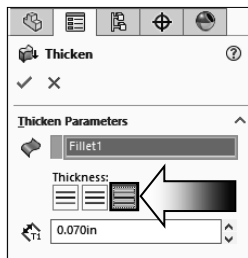

For Thicken Direction, select: **Inside** (arrow).

For Thickness, enter **.070in**.

Click **OK**.

The surface model is thickened into a solid model, and a thickness of .070" is added to the inside wall.



11. Creating a recess cut:

The recess feature helps align the two plastic parts and also enhances their overall appearances.

Select the Top plane and open a **new sketch**.

Select the outer edge as noted and click: **Offset Entities**.

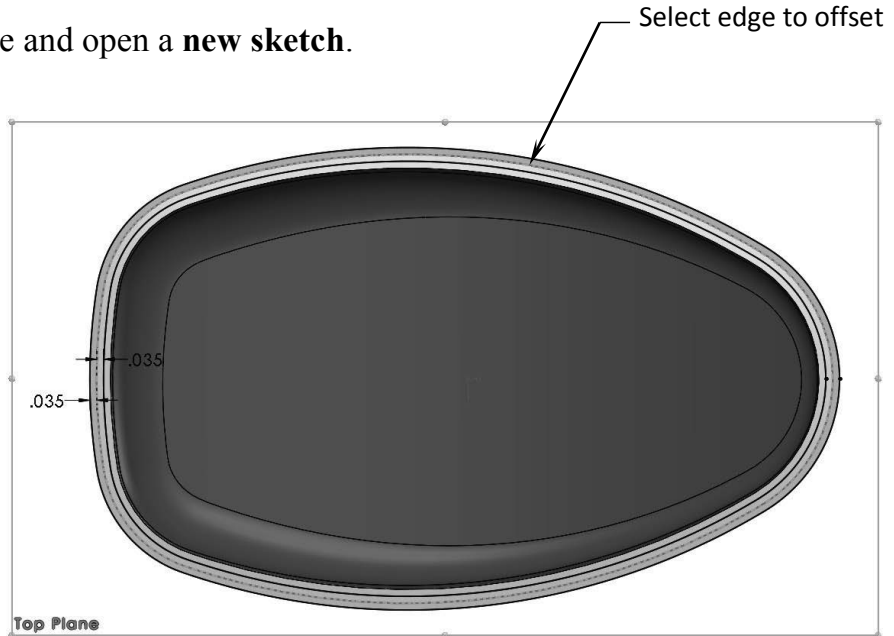
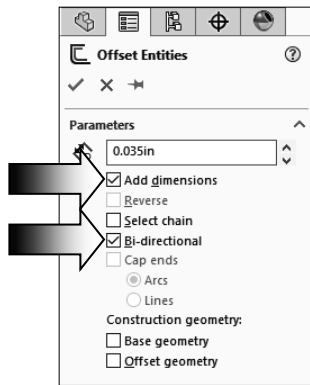

Enter **.035in** for offset Distance.

Enable the checkboxes: **Add Dimensions** and **Bi-Directional** (arrow), click **OK**.

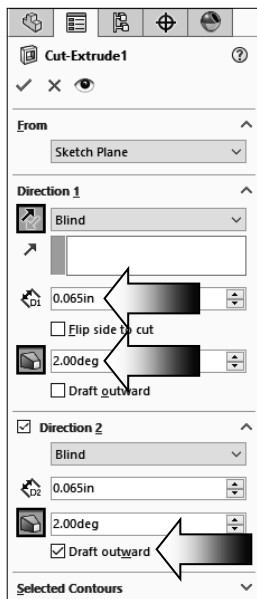

Change to the **Features** tab and click **Extruded Cut**.

Use the default **Blind** type.

Click **Reverse** and enter **.065in.** for depth.

Enable the **Draft** button and enter **2.00deg.**

Enable the **Direction 2** checkbox and apply the same parameters as the first.

Click **Draft Outward** for the direction 2 and click **OK**.



The Complete Guide to Mold Making with SOLIDWORKS 2022 | Surface Repair

The recess cut feature is created. It is .065 inches deep and has a 2 degrees draft all around its perimeter.



Rotate the model to different orientations to inspect the recess cut feature.

Optional: Assign the ABS material to the part, and change the color to gray.



12. Saving your work:

Select **File, Save As**.

Enter: **Mouse_Completed.sldprt**
for the file name.

Click **Save**.

Close all documents.

