

Parametric Modeling with Autodesk® Fusion 360™

Spring 2022 Edition

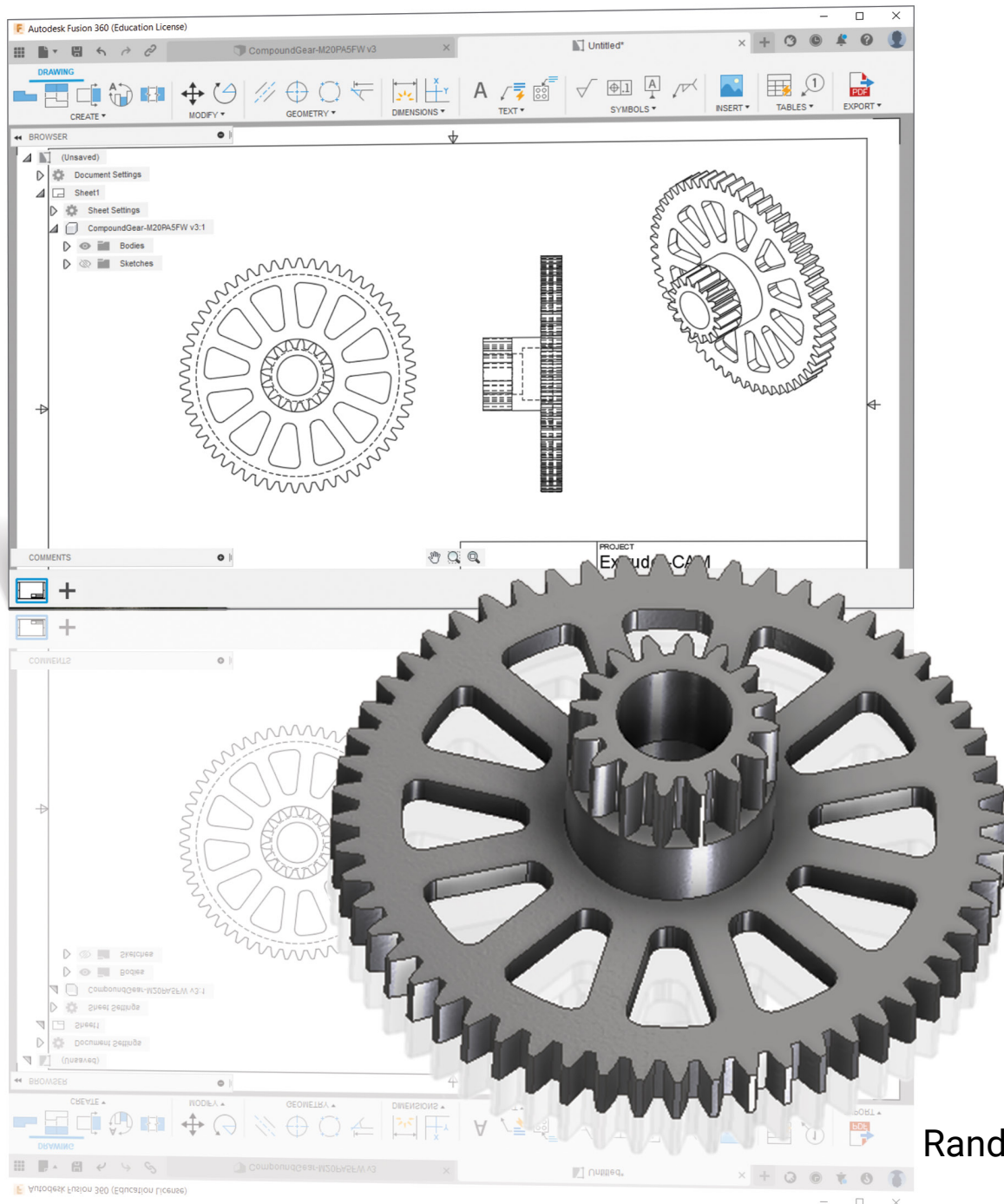

Randy H. Shih

Visit the following websites to learn more about this book:



[amazon.com](https://www.amazon.com)

[Google books](https://books.google.com)

[BARNES & NOBLE](https://www.barnesandnoble.com)

Chapter 2

Parametric Modeling Fundamentals

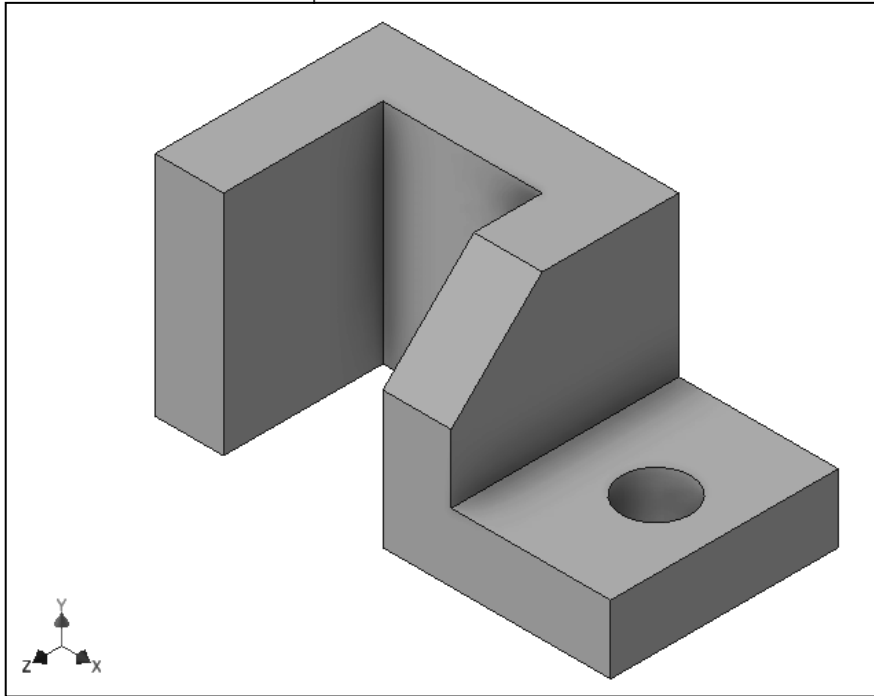

Learning Objectives

- ◆ Create Simple Extruded Solid Models
- ◆ Understand the Basic Parametric Modeling Procedure
- ◆ Create 2D Sketches
- ◆ Understand the “Shape before Size” Design Approach
- ◆ Use the Dynamic Viewing Commands
- ◆ Create and Edit Parametric Dimensions

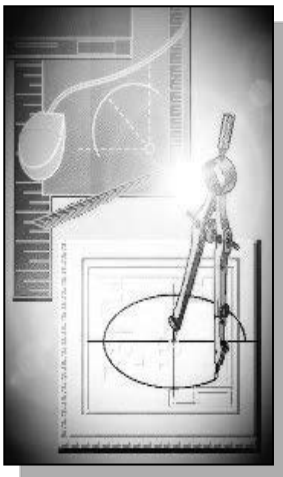

Introduction

The **feature-based parametric modeling** technique enables the designer to incorporate the original **design intent** into the construction of the model. The word *parametric* means the geometric definitions of the design, such as dimensions, can be varied at any time in the design process. Parametric modeling is accomplished by identifying and creating the key features of the design with the aid of computer software. The design variables, described in the sketches as parametric relations, can then be used to quickly modify/update the design.

In Autodesk Fusion 360, the parametric part modeling process involves the following steps:

1. **Create a rough two-dimensional sketch of the basic shape of the base feature of the design.**
2. **Apply/modify constraints and dimensions to the two-dimensional sketch.**
3. **Extrude, revolve, or sweep the parametric two-dimensional sketch to create the base solid feature of the design.**
4. **Add additional parametric features by identifying feature relations and complete the design.**
5. **Perform analyses on the computer model and refine the design as needed.**
6. **Create the desired drawing views to document the design.**

The approach of creating two-dimensional sketches of the three-dimensional features is an effective way to construct solid models. Many designs are in fact the same shape in one direction. Computer input and output devices we use today are largely two-dimensional in nature, which makes this modeling technique quite practical. This method also conforms to the design process that helps the designer with conceptual design along with the capability to capture the *design intent*. Most engineers and designers can relate to the experience of making rough sketches on restaurant napkins to convey conceptual design ideas. Autodesk Fusion 360 provides many powerful modeling and design-tools, and there are many different approaches to accomplishing modeling tasks. The basic principle of **feature-based modeling** is to build models by adding simple features one at a time. In this chapter, the general parametric part modeling procedure is illustrated; a very simple solid model with extruded features is used to introduce the Autodesk Fusion 360 user interface. The display viewing functions and the basic two-dimensional sketching tools are also demonstrated.

The Adjuster Design

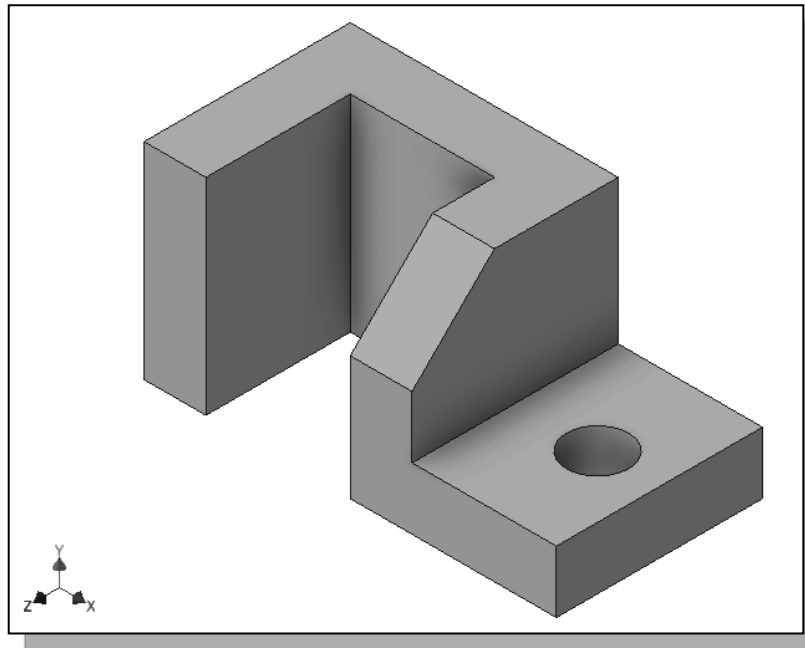

Starting Autodesk Fusion 360

1. Select the **Autodesk Fusion 360** option on the *Start* menu or select the **Autodesk Fusion 360** icon on the desktop to start Autodesk Fusion 360. The Autodesk Fusion 360 *log in* window will appear on the screen.

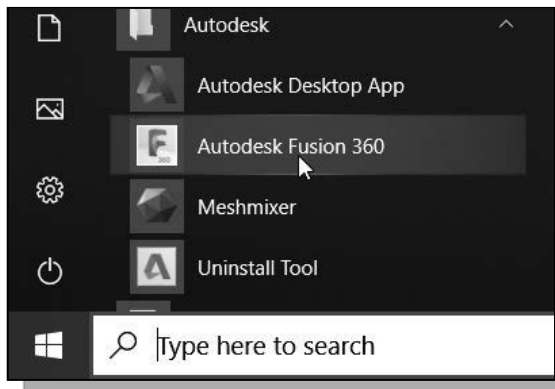

2. In the *Sign In* dialog box, log in with your email or username.

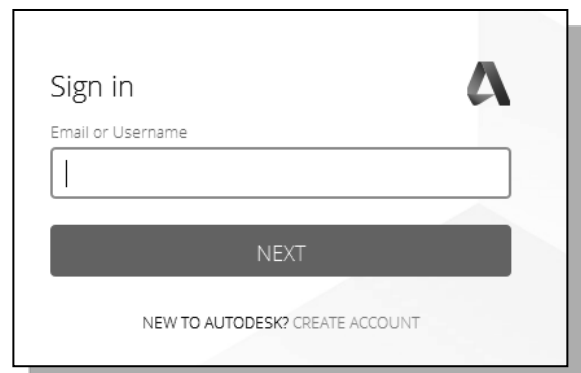

The Autodesk Fusion 360 Screen Layout

The default Autodesk Fusion 360 drawing screen contains the *Quick access* toolbar, the *Modeling* toolbar, the *Navigation* toolbar, the *Model Browser*, the *drawing* area, and the *View Cube*. You may resize the Autodesk Fusion 360 drawing window by clicking and dragging the edges of the window, or relocate the window by clicking and dragging the window title area.

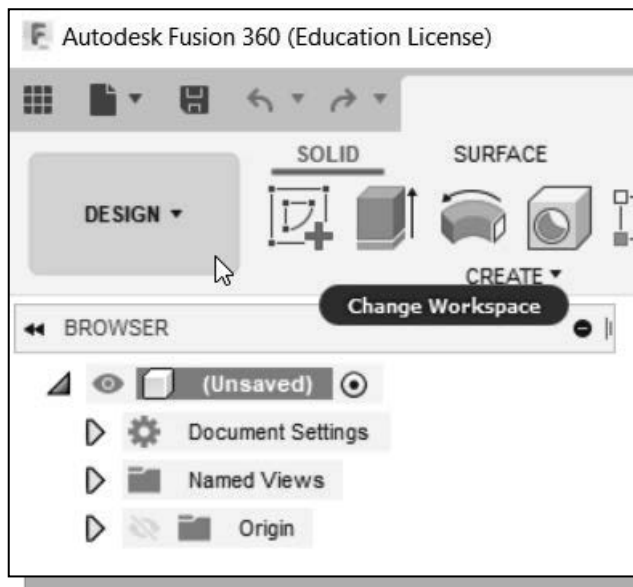
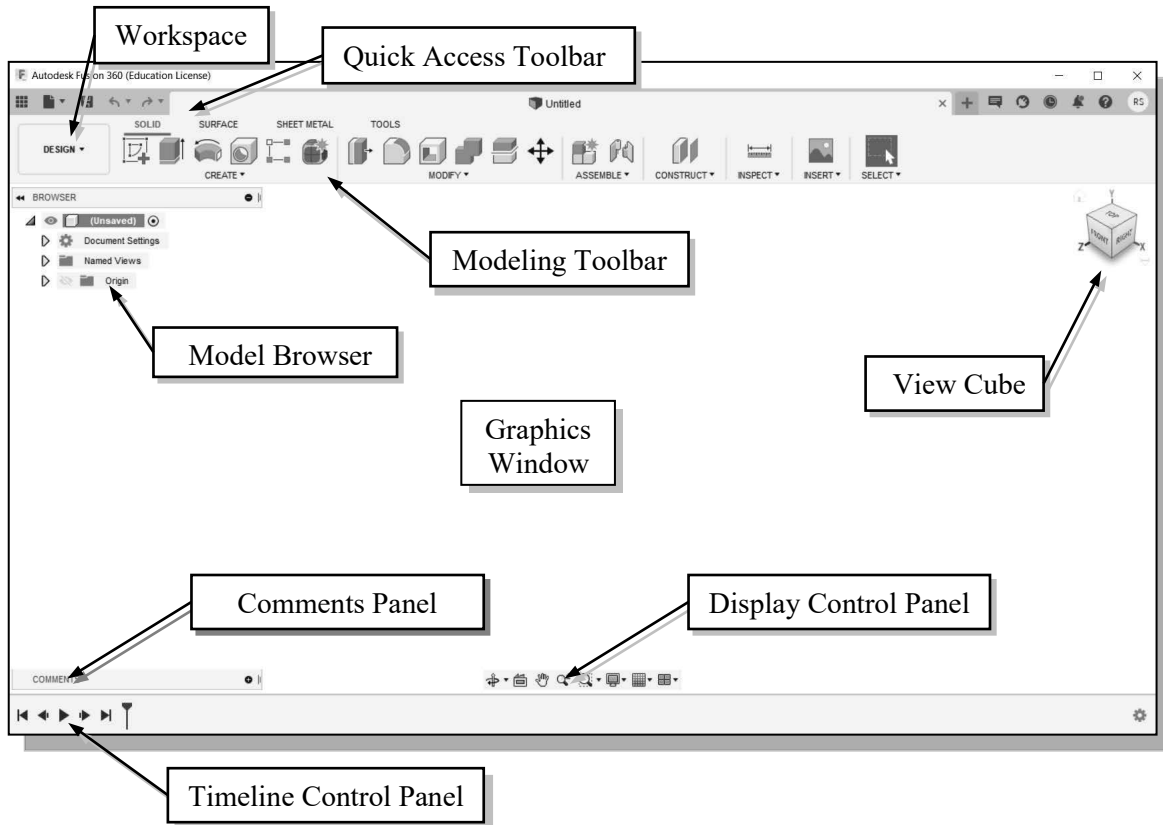

- Autodesk Fusion 360 is an integrated system that can be used to create parts, assembly, animation, simulation, CAM and 2D drawings. By default, the **Design WorkSpace** is activated as shown.

Units Setup

- ❖ Every object we construct in a CAD system is measured in units. We should determine the value of the units within the CAD system before creating the first geometric entities. For example, in one model, a unit might equal one millimeter of the real-world object; in another model, a unit might equal an inch. In Autodesk Fusion 360, the **Document Settings** option can be used to quickly display and also switch to using a different units set.

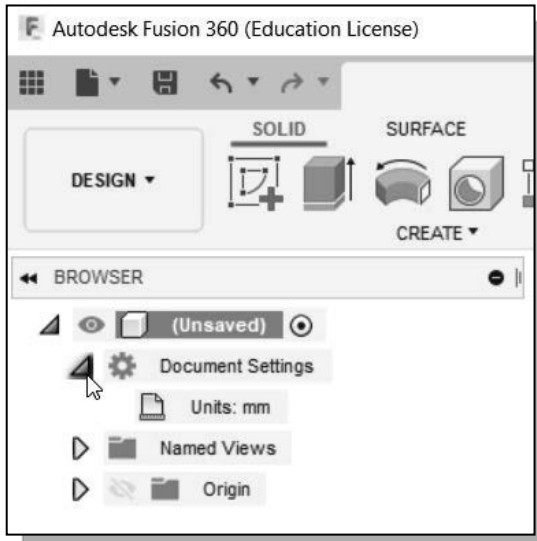

1. Click on the triangle icon next to the **Document Settings** option in the Browser area to show the default units as shown. Note the current units is set to the millimeter (mm) units as shown.

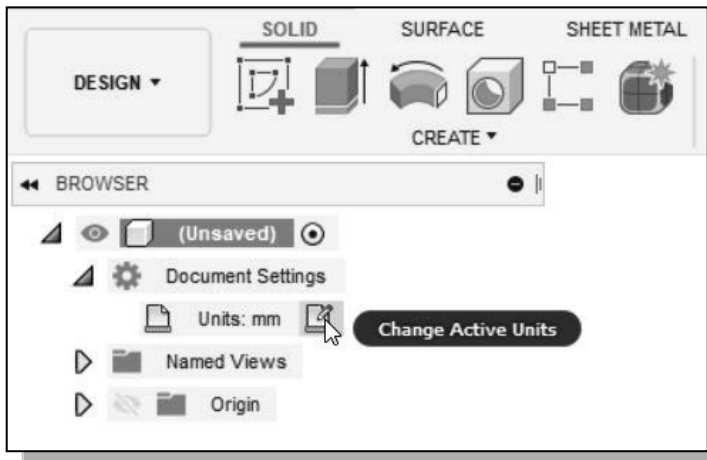

2. Click on the **Change Active Units** option in the Browser area as shown. We will use the inch (in) units for this example.

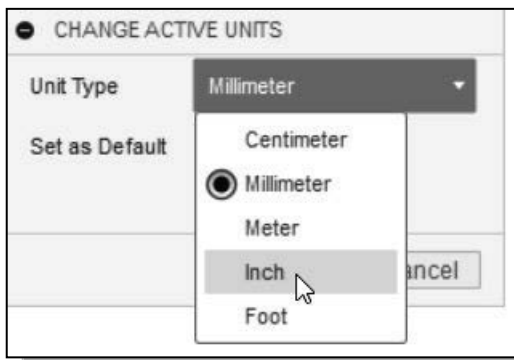

3. In the **Units** list, select **Inch** as shown.
4. Pick **OK** to exit the **Change Active Units** dialog box.

Sketch Plane – It is an XY monitor, but an XYZ World

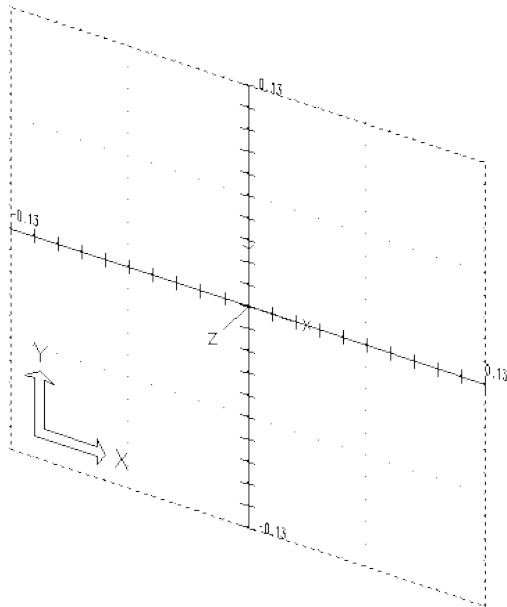

Design modeling software is becoming more powerful and user friendly, yet the system still does only what the user tells it to do. When using a geometric modeler, we therefore need to have a good understanding of what its inherent limitations are.

In most 3D geometric modelers, 3D objects are located and defined in what is usually called **world space** or **global space**. Although a number of different coordinate systems can be used to create and manipulate objects in a 3D modeling system, the objects are typically defined and stored using the world space. The world space is usually a **3D Cartesian coordinate system** that the user cannot change or manipulate.

In engineering designs, models can be very complex, and it would be tedious and confusing if only the world coordinate system were available. Practical 3D modeling systems allow the user to define **Local Coordinate Systems (LCS)** or **User Coordinate Systems (UCS)** relative to the world coordinate system. Once a local coordinate system is defined, we can then create geometry in terms of this more convenient system.

Although objects are created and stored in 3D space coordinates, most of the geometric entities can be referenced using 2D Cartesian coordinate systems. Typical input devices such as a mouse or digitizer are two-dimensional by nature; the movement of the input device is interpreted by the system in a planar sense. The same limitation is true of common output devices, such as CRT displays and plotters. The modeling software performs a series of three-dimensional to two-dimensional transformations to correctly project 3D objects onto the 2D display plane.

The Autodesk Fusion 360 **sketching plane** is a special construction approach that enables the planar nature of the 2D input devices to be directly mapped into the 3D coordinate system. The *sketching plane* is a local coordinate system that can be aligned to an existing face of a part, or a reference plane.

Think of the sketching plane as the surface on which we can sketch the 2D sections of the parts. It is similar to a piece of paper, a white board, or a chalkboard that can be attached to any planar surface. The first sketch we create is usually drawn on one of the established datum planes. Subsequent sketches/features can then be created on sketching planes that are aligned to existing **planar faces of the solid part** or **datum planes**.

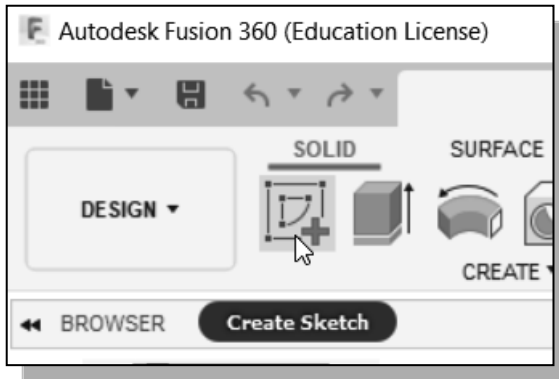

1. Activate the **Create Sketch** icon with a single click of the left-mouse-button.

2. Move the cursor over the right vertical plane, the *XY Plane*, in the graphics area. When the *XY Plane* is highlighted, click once with the **left-mouse-button** to select the *Plane* as the sketching plane for the new sketch.

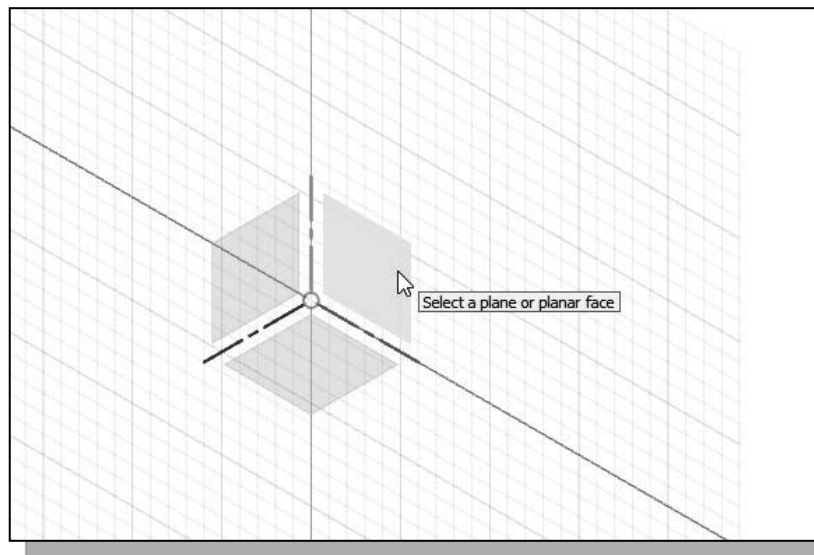

- The *sketching plane* is a reference location where two-dimensional sketches are created. Note that the *sketching plane* can be any planar part surface or datum plane.

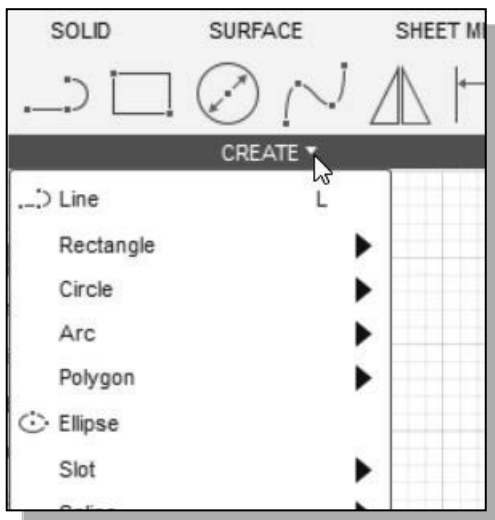

3. Click and press on the **Sketch** tab in the main *Ribbon* area to display the additional available sketching tools as shown. Also note the **Sketch Palette** panel is also activated with a variety of sketching options.

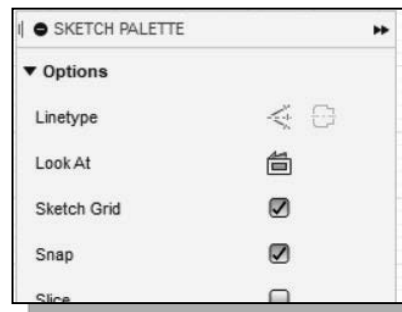

Creating Rough Sketches

Quite often during the early design stage, the shape of a design may not have any precise dimensions. Most conventional CAD systems require the user to input the precise lengths and locations of all geometric entities defining the design, which are not available during the early design stage. With *parametric modeling*, we can use the computer to elaborate and formulate the design idea further during the initial design stage. With Autodesk Fusion 360, we can use the computer as an electronic sketchpad to help us concentrate on the formulation of forms and shapes for the design. This approach is the main advantage of *parametric modeling* over conventional solid-modeling techniques.

As the name implies, a **rough sketch** is not precise at all. When sketching, we simply sketch the geometry so that it closely resembles the desired shape. Precise scale or lengths are not needed. Autodesk Fusion 360 provides many tools to assist us in finalizing sketches. For example, geometric entities such as horizontal and vertical lines are set automatically. However, if the rough sketches are poor, it will require much more work to generate the desired parametric sketches. Here are some general guidelines for creating sketches in Autodesk Fusion 360:

- **Create a sketch that is proportional to the desired shape.** Concentrate on the shapes and forms of the design.
 - **Keep the sketches simple.** Leave out small geometry features such as fillets, rounds and chamfers. They can easily be placed using the **Fillet** and **Chamfer** commands after the parametric sketches have been established.
 - **Exaggerate the geometric features of the desired shape.** For example, if the desired angle is 85 degrees, create an angle that is 50 or 60 degrees. Otherwise, Autodesk Fusion 360 might assume the intended angle to be a 90-degree angle.
 - **Draw the geometry so that it does not overlap.** The geometry should eventually form a closed region. *Self-intersecting* geometry shapes are not allowed.
 - **The sketched geometric entities should form a closed region.** To create a solid feature, such as an extruded solid, a closed region is required so that the extruded solid forms a 3D volume.
- **Note:** The concepts and principles involved in *parametric modeling* are very different, and sometimes they are totally opposite, to those of conventional computer aided drafting. In order to understand and fully utilize Autodesk Fusion 360's functionality, it will be helpful to take a *Zen* approach to learning the topics presented in this text: **Have an open mind and temporarily forget your experiences using conventional Computer Aided Drafting systems.**

Step 1: Creating a Rough Sketch

The *Sketch* toolbar provides tools for creating the basic geometry that can be used to create features and parts.

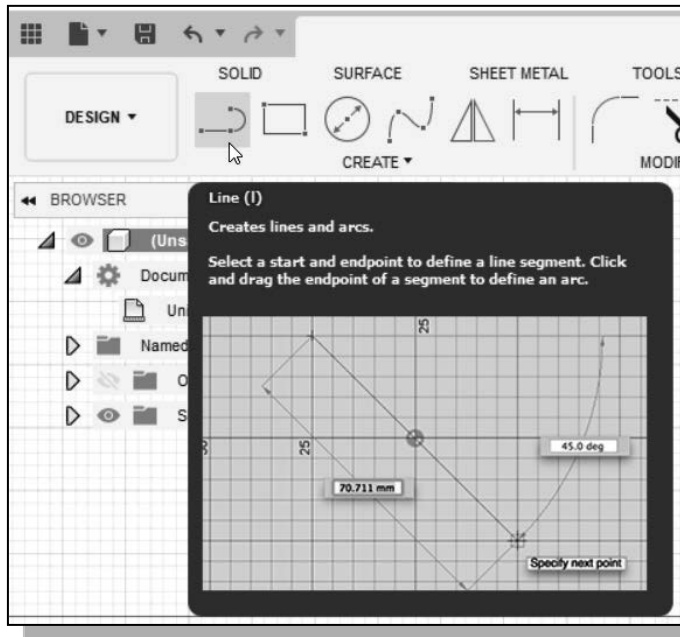

1. Move the graphics cursor to the **Line** icon in the *Sketch* toolbar. A *Help-tip box* appears next to the cursor and a brief description of the command is displayed at the bottom of the drawing screen: “Creates lines and arcs.”
2. Select the icon by clicking once with the **left-mouse-button**; this will activate the **Line** command. *Autodesk Fusion 360* expects us to identify the starting location of a straight line.

Graphics Cursors

Notice a crosshair cursor is shown when graphical input is expected.

1. Left-click a starting point for the shape, roughly just below the center of the graphics window.
2. As you move the graphics cursor, you will see a digital readout next to the cursor and also in the *Status Bar* area at the bottom of the window. The readout gives you the cursor location, the line length, and the angle of the line measured from horizontal. Move the cursor around and you will notice different symbols appear at different locations.

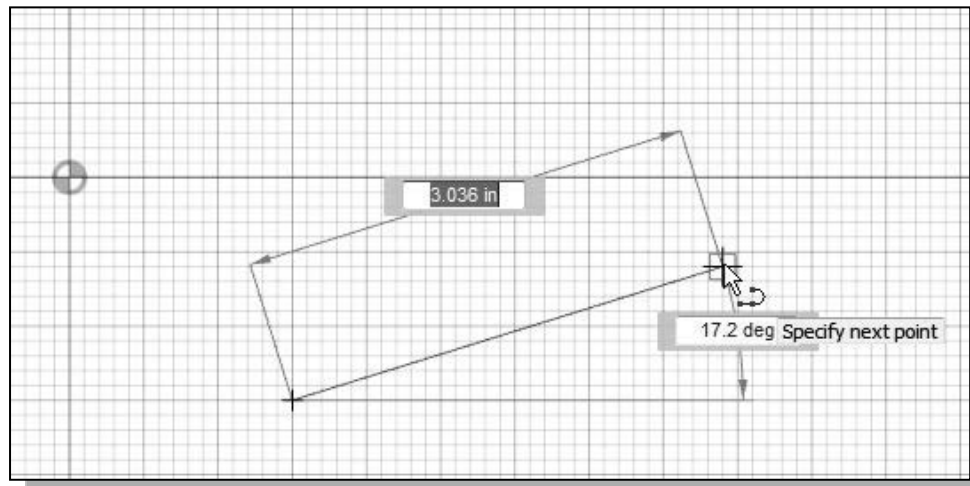

3. Move the graphics cursor toward the right side of the graphics window and create a horizontal line as shown below (**Point 2**). Notice the geometric constraint symbol, a short horizontal line indicating the geometric property, is displayed.

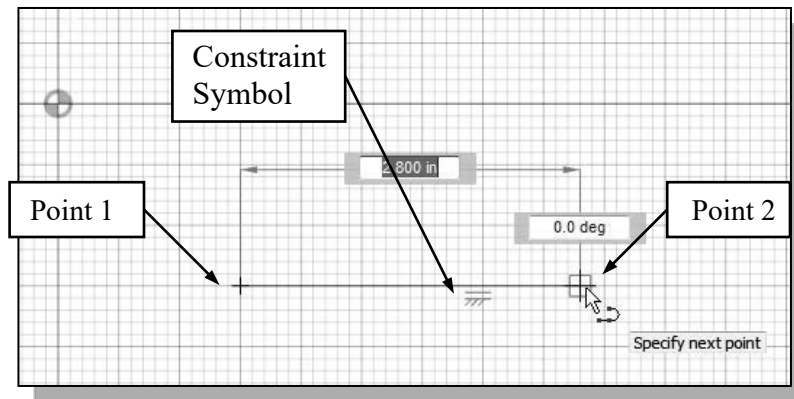

Geometric Constraint Symbols

Autodesk Fusion 360 displays different visual clues, or symbols, to show you alignments, perpendicularities, tangencies, etc. These constraints are used to capture the *design intent* by creating constraints where they are recognized. Autodesk Fusion 360 displays the governing geometric rules as models are built. To prevent constraints from forming, hold down the **[Ctrl]** key while creating an individual sketch curve. For example, while sketching line segments with the **Line** command, endpoints are joined with a **Coincident constraint**, but when the **[Ctrl]** key is pressed and held, the inferred constraint will not be created.

	Vertical	indicates a line is vertical
	Horizontal	indicates a line is horizontal
	Dashed line	indicates the alignment is to the center point or endpoint of an entity
	Parallel	indicates a line is parallel to other entities
	Perpendicular	indicates a line is perpendicular to other entities
	Coincident	indicates the cursor is at the endpoint of an entity
	Concentric	indicates the cursor is at the center of an entity
	Tangent	indicates the cursor is at tangency points to curves

1. Complete the sketch as shown below, creating a closed region ending at the starting point (**Point 1**). Do not be overly concerned with the actual size of the sketch. Note that all line segments are sketched horizontally or vertically.

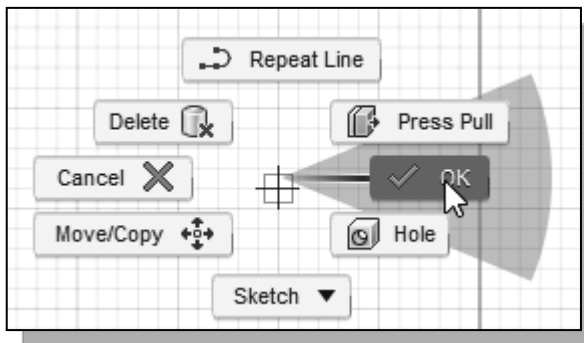
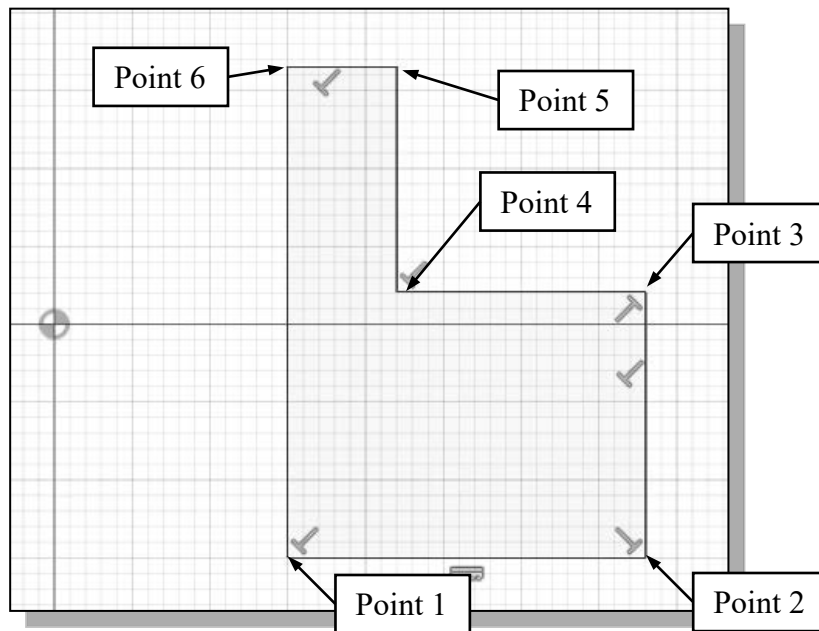

2. Inside the graphics window, click once with the **right-mouse-button** to display the option menu. Select **[OK]** in the pop-up menu, or hit the **[Esc]** key once to end the Sketch Line command.

Step 2: Apply/Modify Constraints and Dimensions

As the sketch is made, Autodesk Fusion 360 automatically applies some of the geometric constraints (such as horizontal, parallel, and perpendicular) to the sketched geometry. We can continue to modify the geometry, apply additional constraints, and/or define the size of the existing geometry. In this example, we will illustrate adding dimensions to describe the sketched entities.

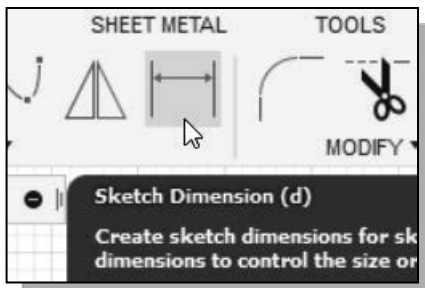

1. In the sketch toolbar, select the **Sketch Dimension** command as shown. The Sketch Dimension command is generally known as *Smart Dimensioning* in parametric modeling.

- The message “*Select Geometry to Dimension*” is displayed in the *Status Bar* area at the bottom of the *Fusion 360* window. Select the bottom horizontal line by left-clicking once on the line.

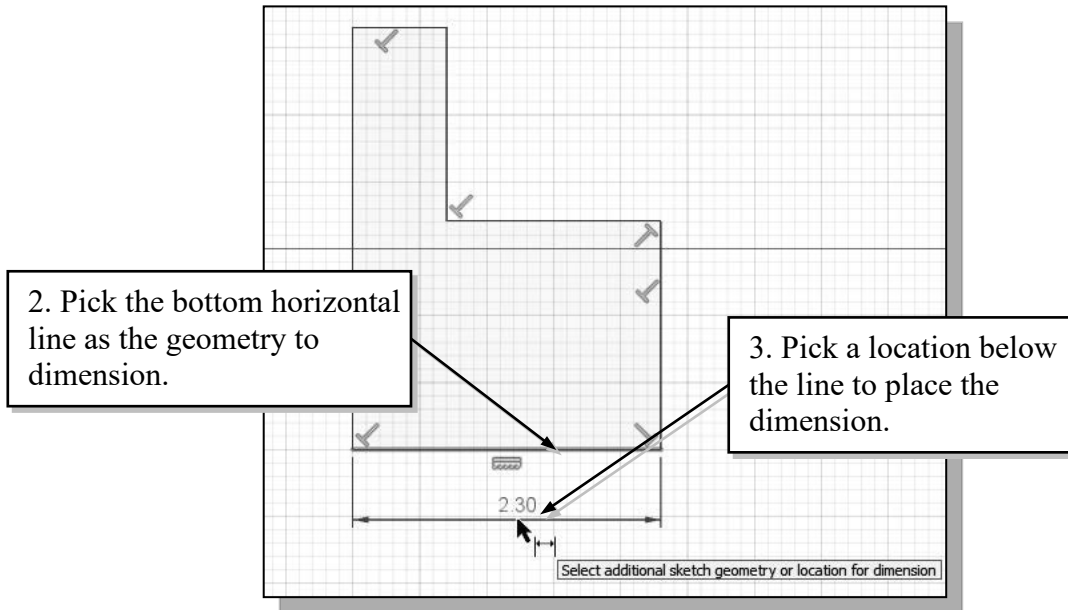

- Move the graphics cursor below the selected line and left-click to place the dimension. (Note that the value displayed on your screen might be different than what is shown in the figure above.)

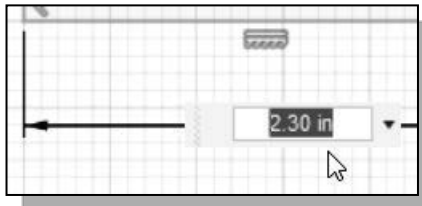

- Accept the default value by hitting the **Enter** key once.

❖ The Sketch Dimension command will create a length dimension if a single line is selected.

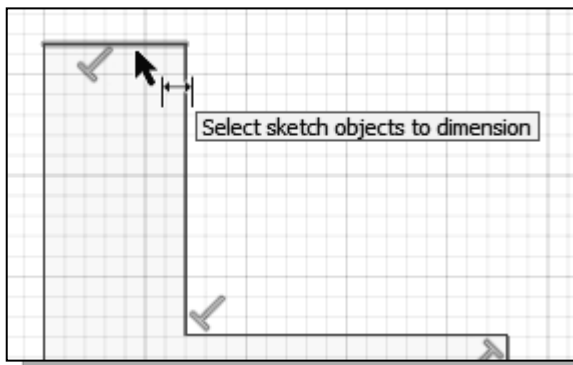

- Select the top-horizontal line as shown in the figure.

- Select the bottom-horizontal line as the second entity to dimension as shown.

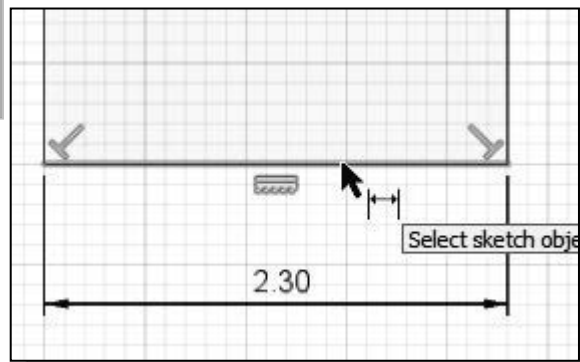

- Pick a location to the left of the sketch to place the dimension.

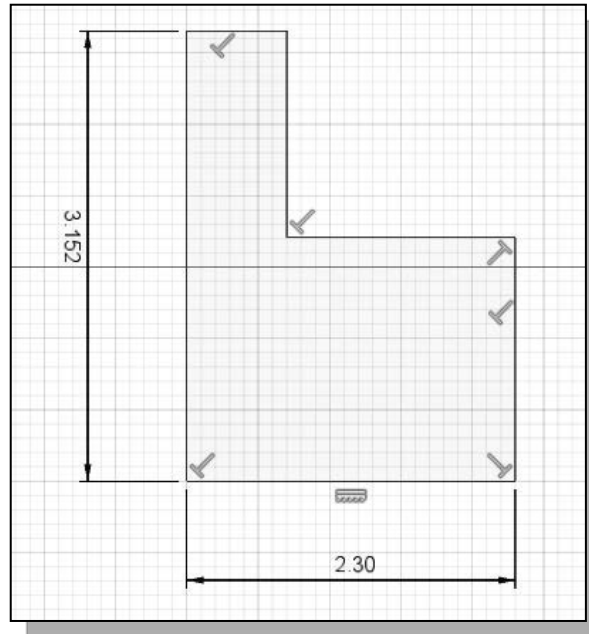

- Accept the default value by hitting the **Enter** key once.
- ❖ When two parallel lines are selected, the Sketch Dimension command will create a dimension measuring the distance between them.
- On your own, repeat the above steps and create additional dimensions (accepting the default values created by Fusion 360) so that the sketch appears as shown. Hit the [ESC] key once to end the Dimension command before proceeding to the next page.

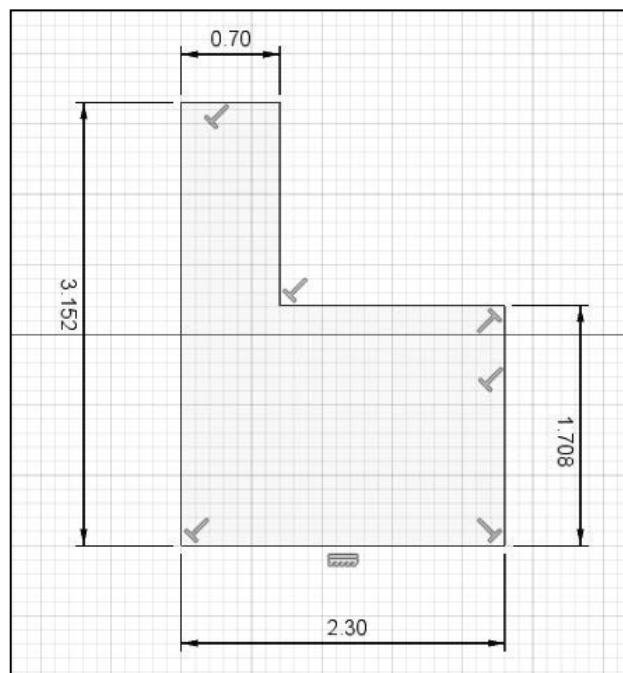

Dynamic Viewing Functions – Zoom and Pan

Autodesk Fusion 360 provides a special user interface called *Dynamic Viewing* that enables convenient viewing of the entities in the graphics window.

1. Click on the **Zoom Window** icon located in the *Navigation* bar as shown.

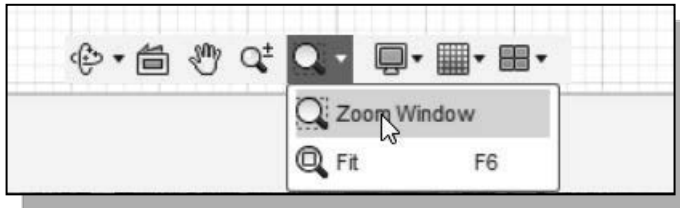

2. Move the cursor near the center of the graphics window.
3. Inside the graphics window, **press and hold down the left-mouse-button**, then move downward to enlarge the current display scale factor.
4. Press the [**Esc**] key once to exit the ZOOM command.
5. Click on the **Pan** icon located next to the Zoom command in the *Navigation* bar. The icon is the picture of a hand.

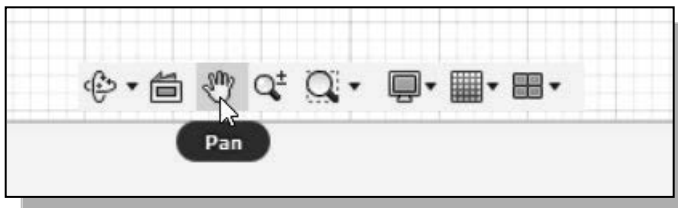

- The **Pan** command enables us to move the view to a different position. This function acts as if you are using a video camera.

6. On your own, use the Zoom and Pan options to reposition the sketch near the center of the screen.

Modifying the Dimensions of the Sketch

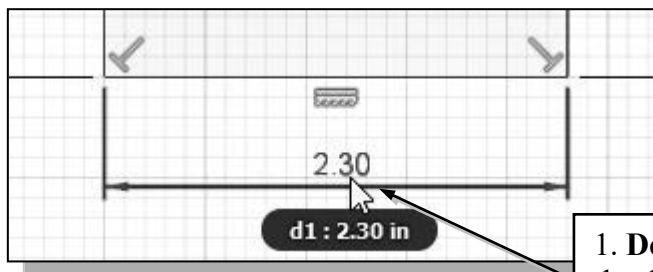

1. Select the dimension that is at the bottom of the sketch by **double-clicking** on the dimension text.

1. **Double-clicking** the dimension text to modify.

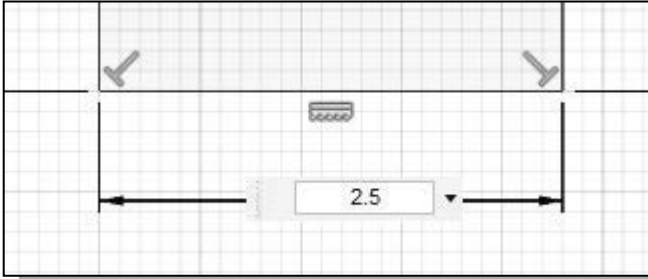

2. In the *Edit Dimension* window, the current length of the line is displayed. Enter **2.5** to set the length of the line.
3. Hit on the **Enter** key once to accept the entered value.

➤ Autodesk Fusion 360 will now update the profile with the new dimension value.

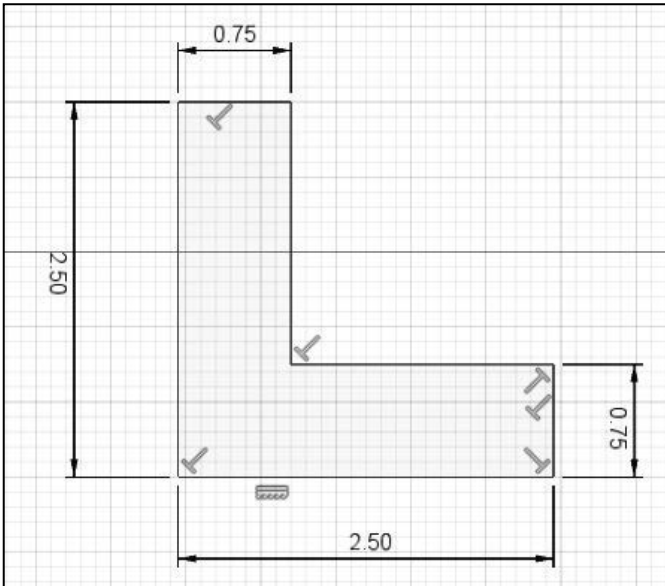

4. On your own, repeat the above steps and adjust the dimensions so that the sketch appears as shown.

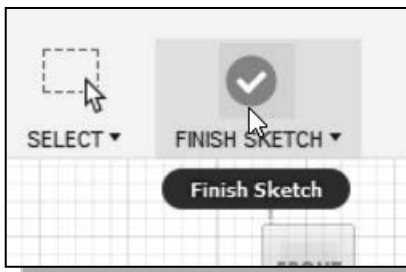

5. In the *Ribbon* toolbar, click once with the **left-mouse-button** on **Finish Sketch** to end the Sketch option.

Step 3: Completing the Base Solid Feature

Now that the 2D sketch is completed, we will proceed to the next step: create a 3D part from the 2D profile. Extruding a 2D profile is one of the common methods that can be used to create 3D parts. We can extrude planar faces along a path. We can also specify a height value and a tapered angle. In Autodesk Fusion 360, each face has a positive side and a negative side; the current face we're working on is set as the default positive side. This positive side identifies the positive extrusion direction, and it is referred to as the face's *normal*.



1. In the *Create toolbar*, select the **Extrude** command by clicking the left-mouse-button on the icon as shown.

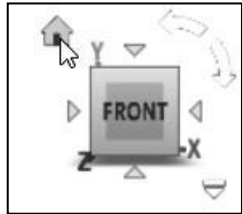

2. Click the **Home View** icon to set the display to the isometric view location.

3. The 2D sketch we just created is pre-selected as the profile as shown.

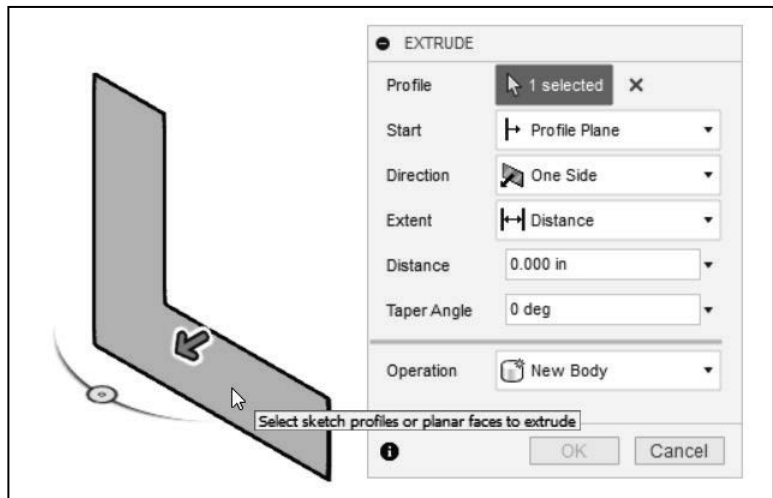

4. In the *Extrude* edit box, enter **2.5** as the extrusion distance.

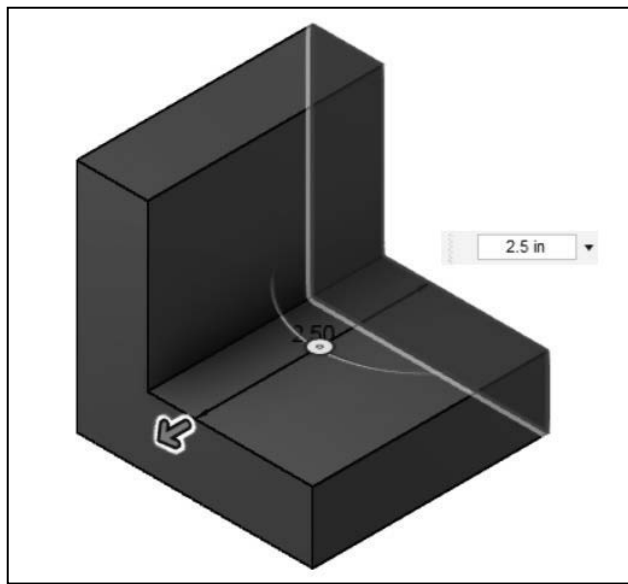

5. Click the **OK** button to proceed with creating the 3D part.
 - Note that all dimensions disappeared from the screen. All parametric definitions are stored in the database and can be re-displayed.

Dynamic Rotation of the 3D Object – Free Orbit

The Free Orbit command allows us to:

- Orbit a part or assembly in the graphics window. Rotation can be around the center mark, free in all directions, or around the *X/Y*-axes in the *3D-Orbit* display.
- Reposition the part or assembly in the graphics window.
- Display isometric or standard orthographic views of a part or assembly.

The Free Orbit tool is accessible while other tools are active. Autodesk Fusion 360 remembers the last used mode when you exit the Orbit command.

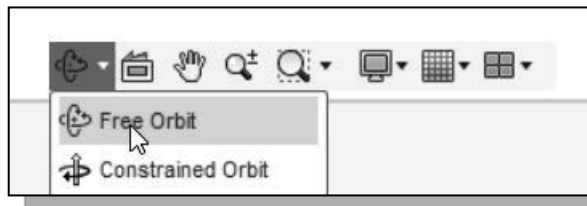

1. Click on the **Free Orbit** icon in the *Navigation* bar.

- The *3D Orbit* display is a circular rim with four handles and a center mark. *3D Orbit* enables us to manipulate the view of 3D objects by clicking and dragging with the left-mouse-button:

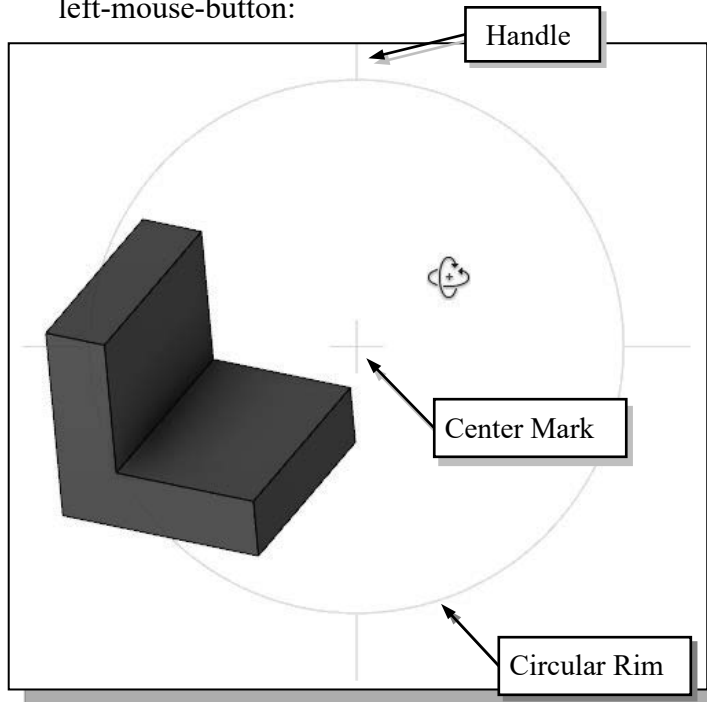

- Drag with the left-mouse-button near the center for free rotation.
- Drag on the handles to orbit around the horizontal or vertical axes.
- Drag on the rim to orbit about an axis that is perpendicular to the displayed view.
- Single left-click to align the center mark of the view.

2. Inside the *circular rim*, press down the left-mouse-button and drag in an arbitrary direction; the *3D Orbit* command allows us to freely orbit the solid model.
3. Move the cursor near the circular rim and notice the cursor symbol changes to a single circle. Drag with the left-mouse-button to orbit about an axis that is perpendicular to the displayed view.

4. Single left-click near the top-handle to align the selected location to the center mark in the graphics window.
5. Activate the **Constrained Orbit** option by clicking on the associated icon as shown.

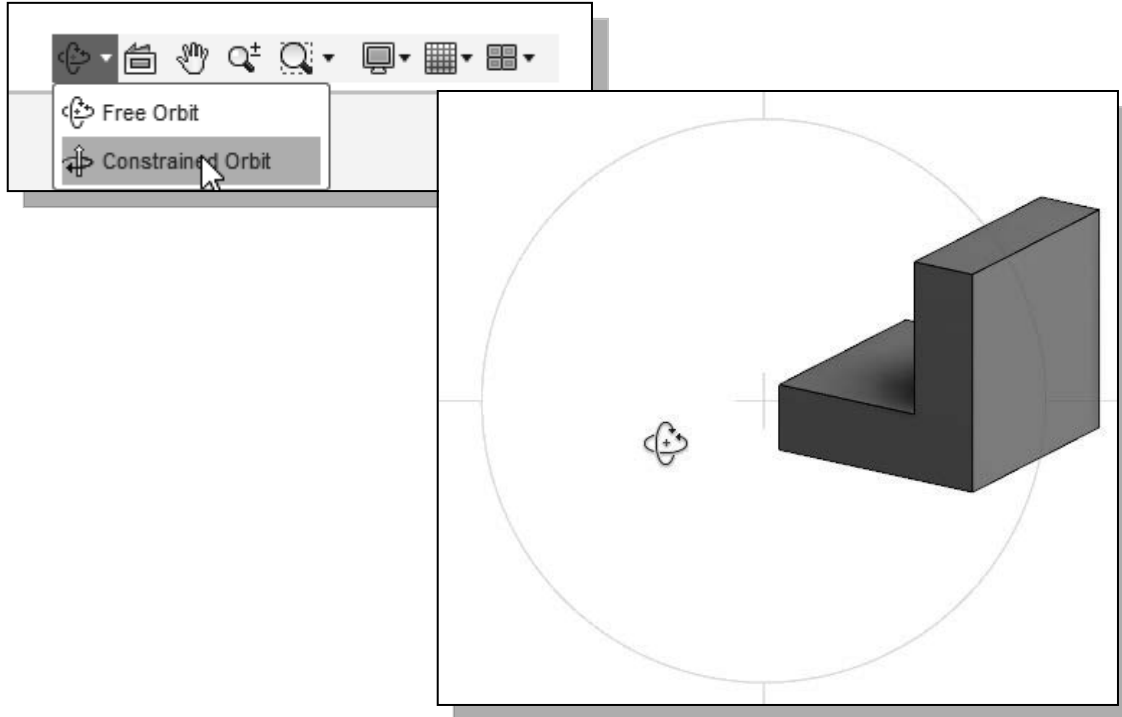

- ❖ *The **Constrained Orbit** can be used to rotate the model about axes in Model Space, equivalent to moving the eye position about the model in latitude and longitude.*
6. On your own, use the different options described in the above steps and familiarize yourself with both of the 3D Orbit commands. Reset the display roughly to the *Isometric* angle before continuing to the next section.
- ❖ Note that while in the 3D Orbit mode, a horizontal marker will be displayed next to the cursor if the cursor is away from the circular rim. This is the exit marker. Left-clicking once will allow you to exit the 3D Orbit command.

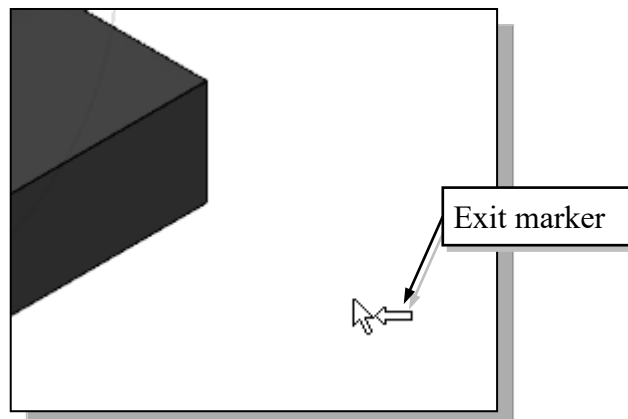

Dynamic Viewing - Quick Keys

We can also use the mouse and the keyboard to access the *Dynamic Viewing* functions. Below are the default Autodesk Fusion 360 quick keys settings; we can use other settings if preferred.

❖ Panning – Press and drag with the mouse wheel

Pressing and dragging with the mouse wheel can also reposition the display. This allows you to reposition the display while maintaining the same scale factor of the display.

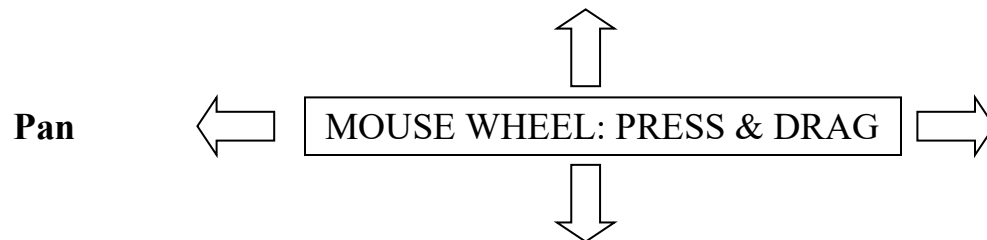

❖ Zooming – Turning the mouse wheel

Turning the mouse wheel can also adjust the scale of the display. Turning forward will reduce the scale of the display, making the entities display smaller on the screen. Turning backward will magnify the scale of the display.

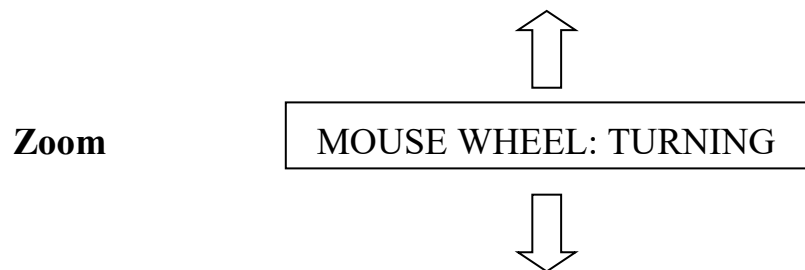

❖ 3D Rotation – Shift and the middle-mouse-button

Hold the **Shift** key down and drag with the middle-mouse-button to orbit the display.

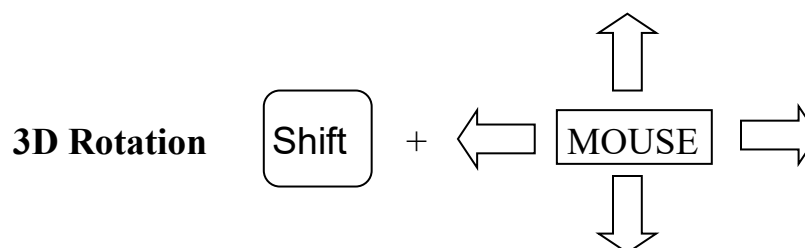

Viewing Tools – Display Control bar and View Cube

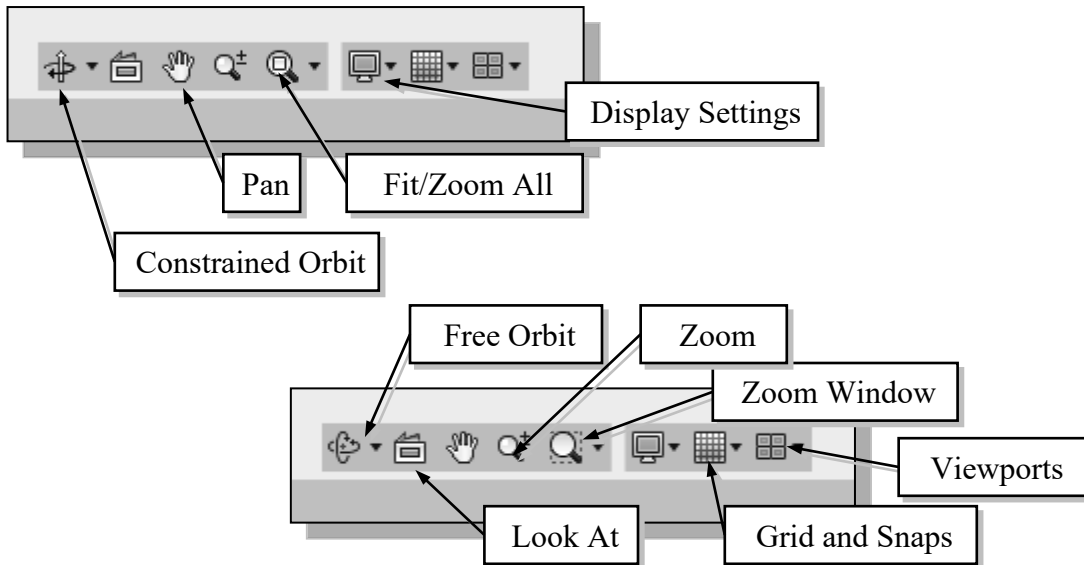

Orbit – In a part or assembly, adds an orbit symbol and cursor to the view. You can orbit the view planar to the screen around the center mark, around a horizontal or vertical axis, or around the X and Y axes.

Look At – In a part or assembly, zooms and orbits the model to display the selected element planar to the screen or a selected edge or line horizontal to the screen. (Not used in drawings.)

Fit/Zoom All – Adjusts the view so that all items on the screen fit inside the graphics window.

Zoom Window – Use the cursor to define a region for the view; the defined region is zoomed to fill the graphics window.

Zoom – Moving upward will reduce the scale of the display, making the entities display smaller on the screen. Moving downward will magnify the scale of the display.

Pan – This allows you to reposition the display while maintaining the same scale factor of the display.

Display settings – This panel contains multiple control to the display related settings, such as Visual Style and Camera.

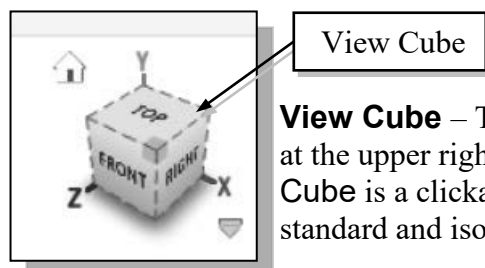

View Cube – The View Cube is a 3D navigation tool that appears at the upper right corner of the *Fusion 360* main window. The View Cube is a clickable interface which allows you to switch between standard and isometric views.

The **View Cube** also provides visual feedback about the current viewpoint of the model as view changes occur. When the cursor is positioned over the **View Cube**, it becomes active and allows you to switch to one of the available preset views, roll the current view, or change to the **Home** view of the model.

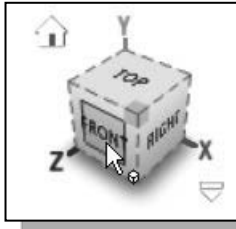

1. Move the cursor over the **ViewCube** and notice the different sides of the **ViewCube** become highlighted and can be activated.
2. Single left-click when the front side is activated as shown. The current view is set to view the front side.

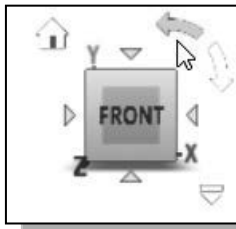

3. Move the cursor over the counterclockwise arrow of the **ViewCube** and notice the orbit option becomes highlighted.
4. Single left-click to activate the counter-clockwise option as shown. The current view is orbited 90 degrees; we are still viewing the front side.

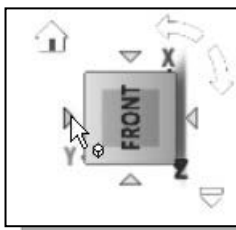

5. Move the cursor over the left arrow of the **ViewCube** and notice the orbit option becomes highlighted.
6. Single left-click to activate the left arrow option as shown. The current view is now set to view the top side.

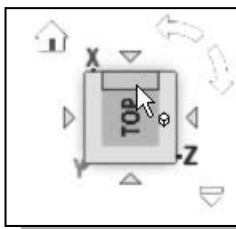

7. Move the cursor over the top edge of the **ViewCube** and notice the roll option becomes highlighted.
8. Single left-click to activate the roll option as shown. The view will be adjusted to roll 45 degrees.

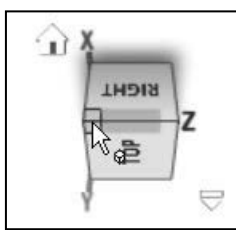

9. Move the cursor over one of the corners of the **ViewCube** and drag with the left-mouse-button to activate the **Free Rotation** option.

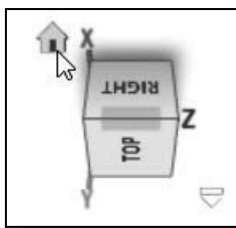

10. Move the cursor over the home icon of the **ViewCube** and notice the **Home View** option becomes highlighted.
11. Single left-click to activate the **Home View** option as shown. The view will be adjusted back to the default *isometric view*.

Display Modes

The **Visual Style** in the *Display Settings* list has six display-modes showing shaded renderings and wireframe representations of the model.

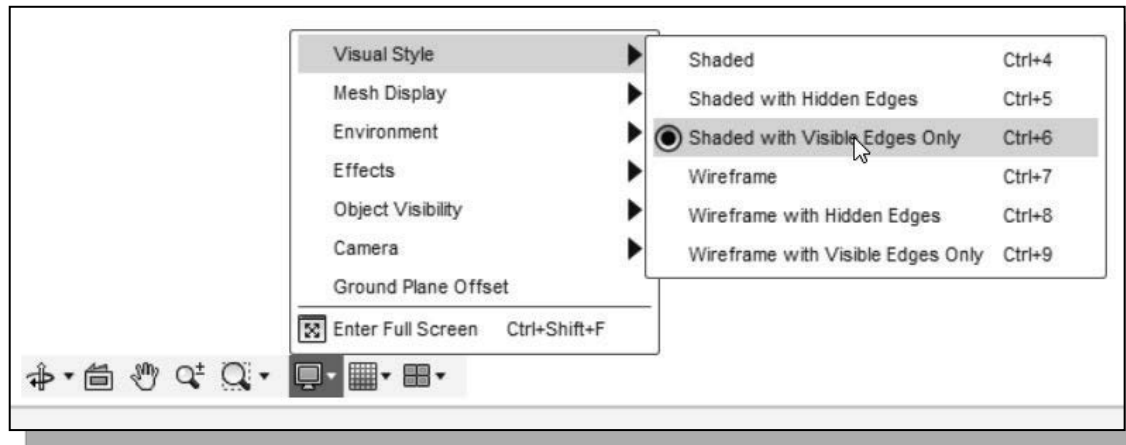

❖ Shaded Solid Modes:

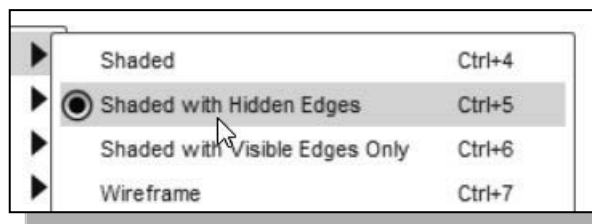

The *Shaded Solid* display modes generate high quality shaded images of the 3D object.

❖ Wireframe Display Modes:

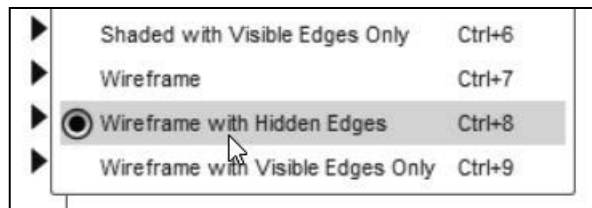

The *Wireframe Image* display options allow the display of the 3D objects using the wireframe representation scheme.

Orthographic vs. Perspective

Besides the above basic display modes, we can also choose orthographic view using the parallel edges representation scheme or perspective view using the perspective, nonparallel edges, and representation scheme of the display. Click on the **Camera** list in the *Display Settings* to select the different display options as shown in the figure.

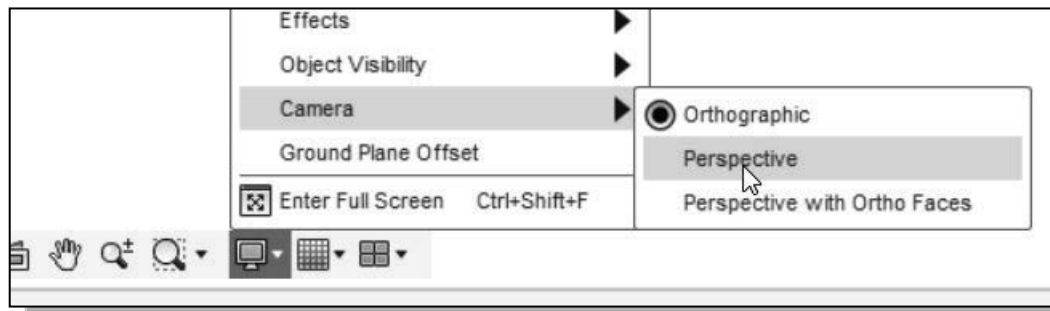

Step 4-1: Adding an Extruded Feature

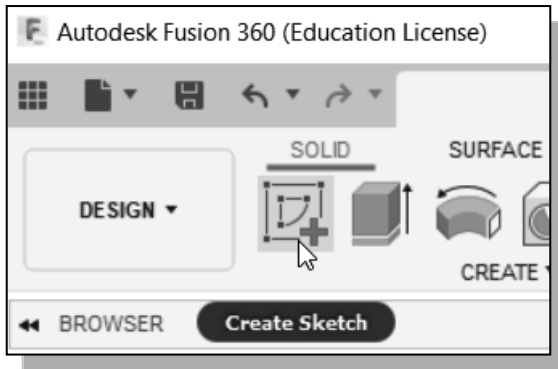

1. In the *Create* toolbar, select the **Create Sketch** command by left-clicking once on the icon.

2. Next to the cursor, the message “*Select a plane or planar face*” is displayed. Autodesk Fusion 360 expects us to identify a planar surface where the 2D sketch of the next feature is to be created. Move the graphics cursor on the 3D part and notice that Autodesk Fusion 360 will automatically highlight feasible planes and surfaces as the cursor is on top of the different surfaces. Pick the top horizontal face of the 3D solid object.

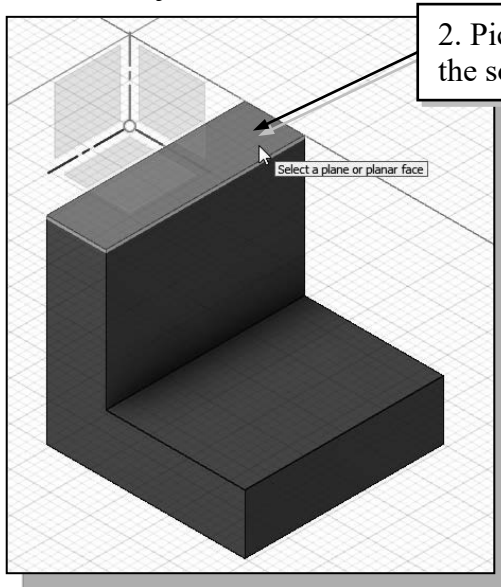

2. Pick the top face of the solid model.

- Note that the sketch plane is aligned to the selected face. Autodesk Fusion 360 automatically establishes a User-Coordinate-System (UCS) and records its location with respect to the part on which it was created.

- Next, we will create and profile another sketch, a rectangle, which will be used to create another extrusion feature that will be added to the existing solid object.

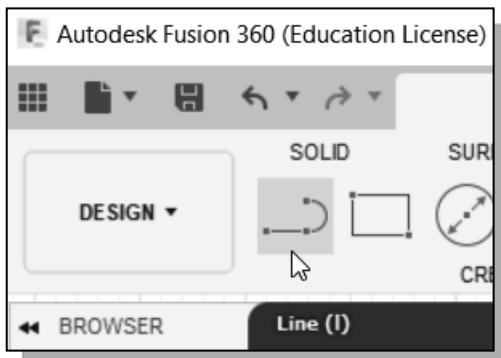

3. Select the **Line** command by clicking once with the **left-mouse-button** on the icon in the *Sketch* tab on the Ribbon.

4. Create a sketch, starting at the top left corner of the solid model, with six line segments perpendicular/parallel to the solid model as shown below.

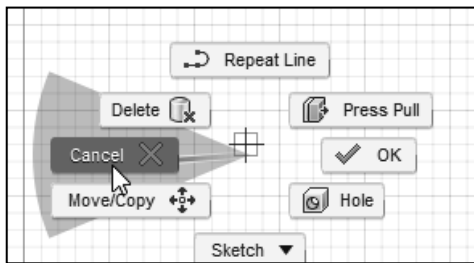
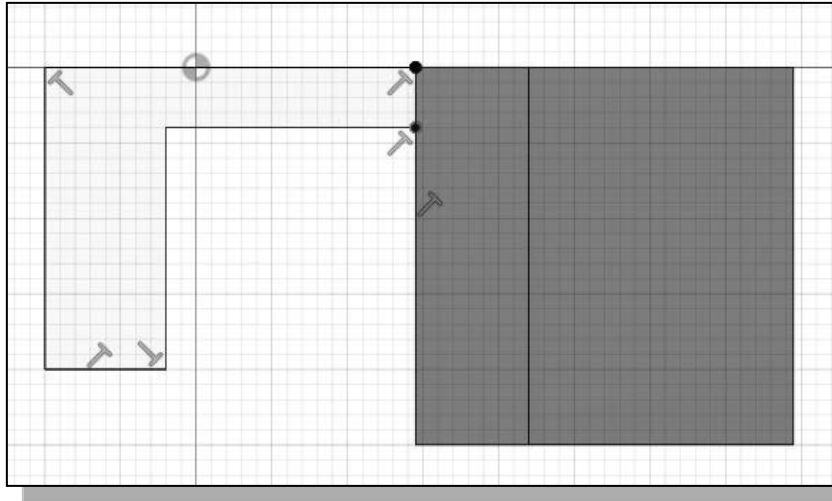

5. Inside the graphics window, click once with the **right-mouse-button** to display the option menu. Select **Cancel (ESC)** in the pop-up menu to end the Line command.

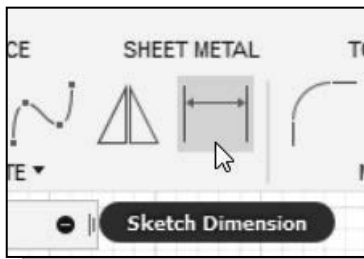

6. Select the **Sketch Dimension** command in the *Sketch* toolbar. The Sketch Dimension command allows us to quickly create and modify dimensions. You can also hit [D] on the keyboard to activate this command.

7. Create the four size dimensions, set values to **2.5** & **.75**, to describe the size of the sketch as shown.

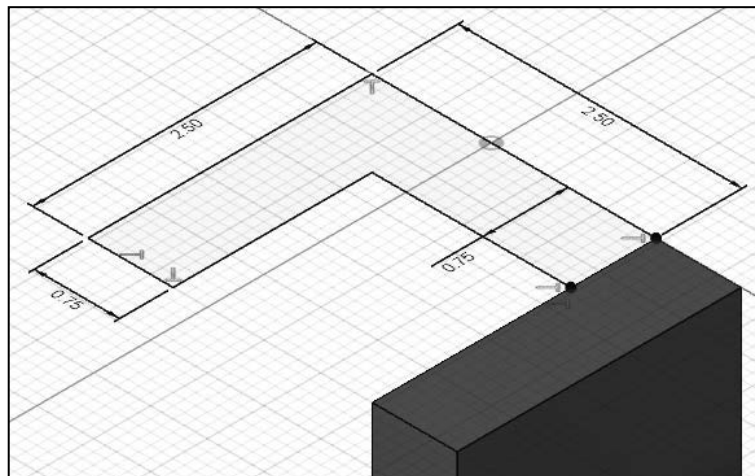

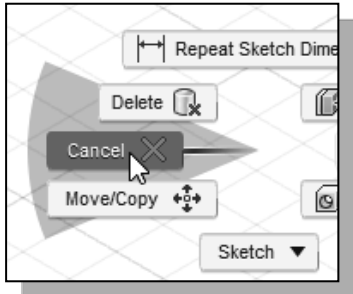

8. Inside the graphics window, click once with the **right-mouse-button** to display the option menu. Select **Cancel** in the pop-up menu to end the Sketch Dimension command.



9. In the *Ribbon* area, select **Finish Sketch** to end the Sketch command.



10. In the *Create toolbar*, select the **Extrude** command by left-clicking on the icon.

11. Select inside the 2D sketch we just created as the region to extrude.

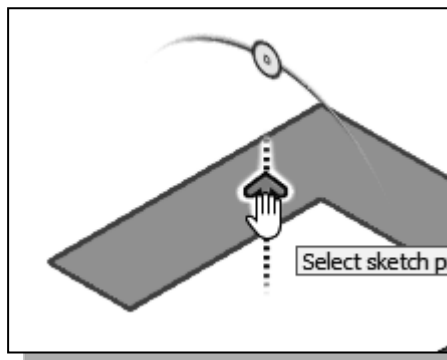
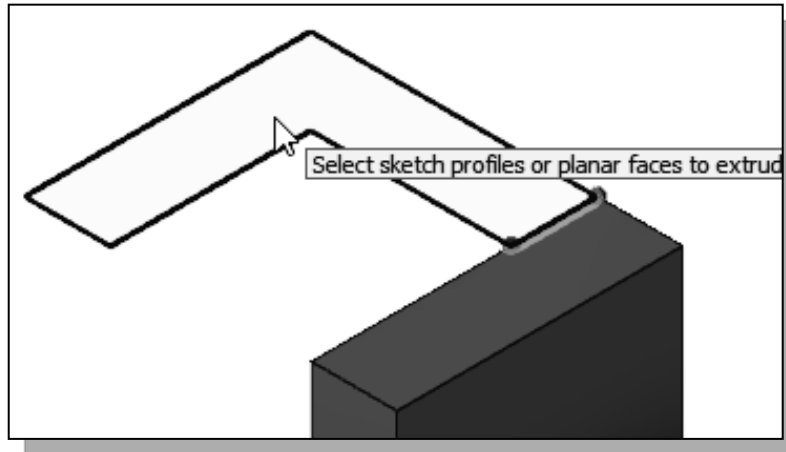

12. Move the cursor on top of the arrow; notice the dashed line appears as shown. We can drag the arrow, with the left mouse button, to set the extrusion distance and direction.

13. Drag the arrow **downward**, with the left mouse button, and set the extrusion distance to **-2.5** as shown.

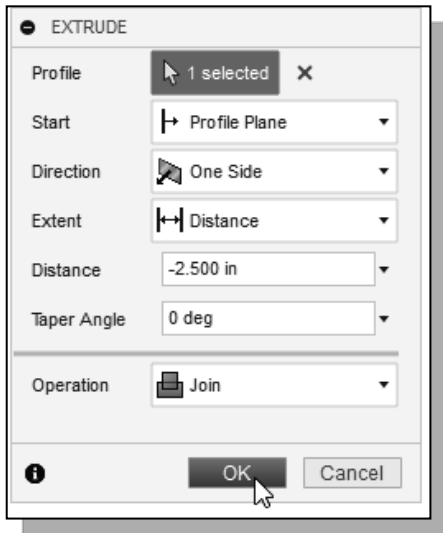
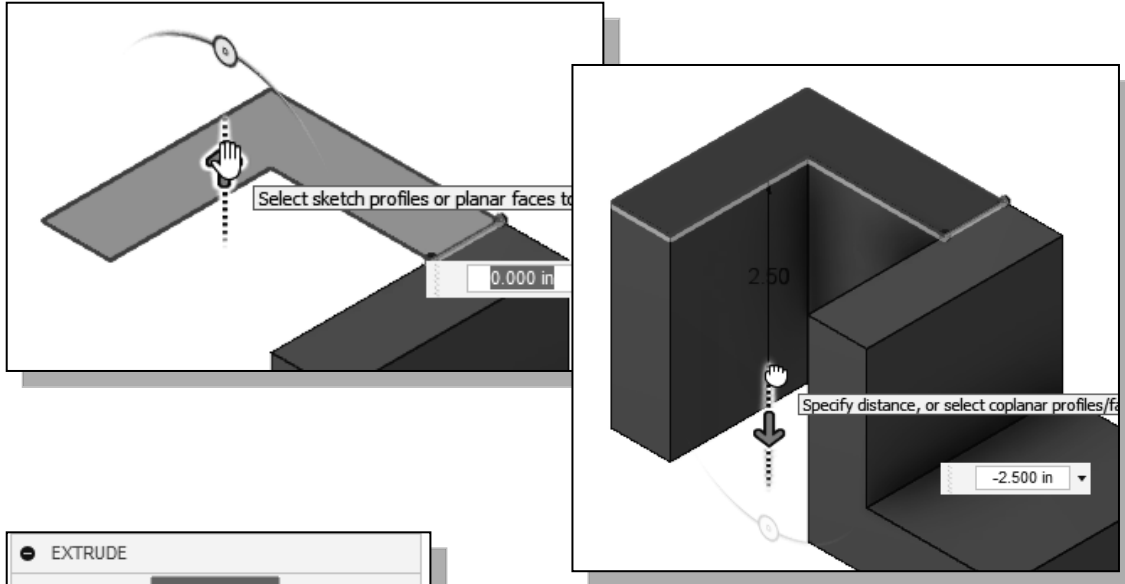

14. In the *Extrude* pop-up window, confirm the settings are set to **Join** and **-2.50** in as shown.

15. Click on the **OK** button to proceed with creating the extruded feature.

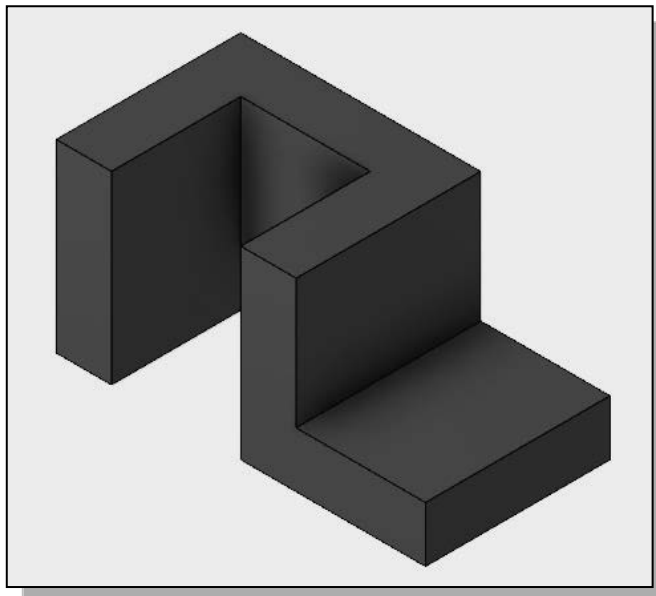

Step 4-2: Adding a Cut Feature

Next, we will create and profile a circle, which will be used to create a cut feature that will be added to the existing solid object.

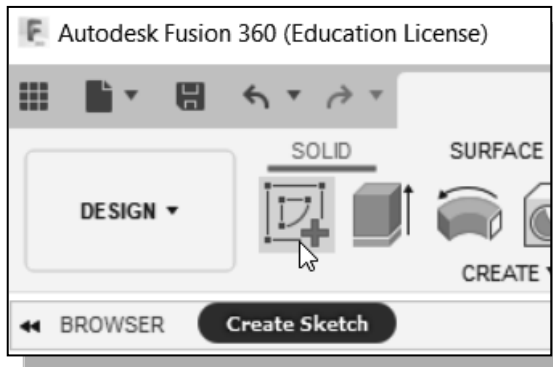

1. In the *Create* toolbar, select the **Create Sketch** command by left-clicking once on the icon.
2. Click on the **Minimize** icon to minimize the *Sketch Palette*.

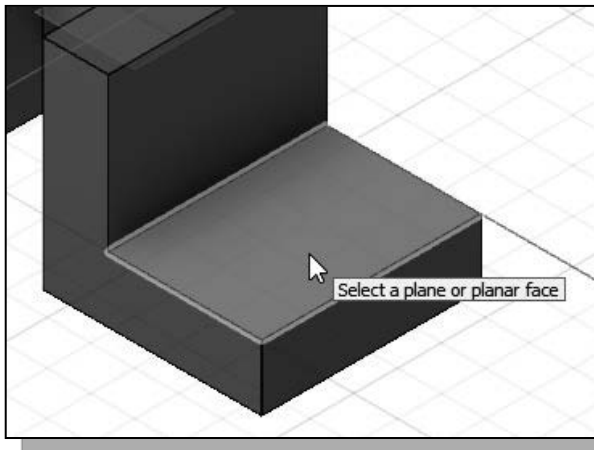
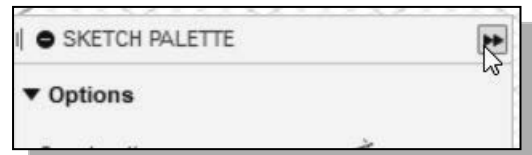

3. Pick the top horizontal face of the 3D solid model as shown.
 - Note that the sketch plane is aligned to the selected face. Autodesk Fusion 360 automatically establishes a User-Coordinate-System (UCS) and records its location with respect to the part on which it was created.

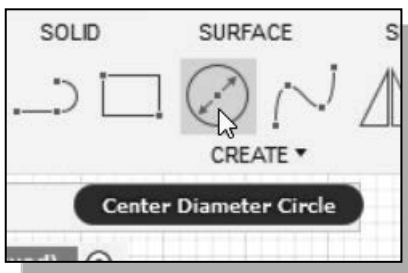

4. Select the **Center Diameter circle** command by clicking once with the **left-mouse-button** on the icon in the *Sketch* toolbar as shown.

5. Create a circle of arbitrary size on the top face of the solid model as shown.

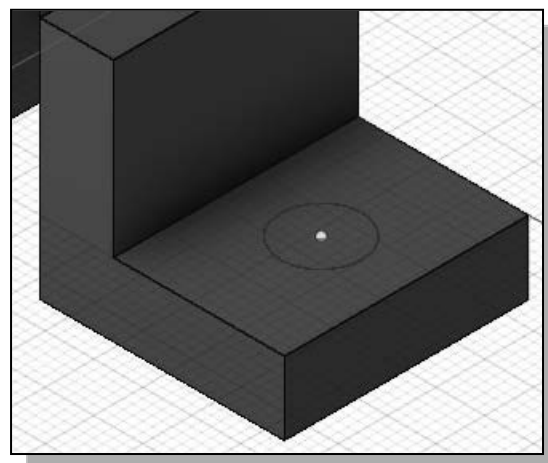

- On your own, create and modify the dimensions of the sketch as shown in the figure.

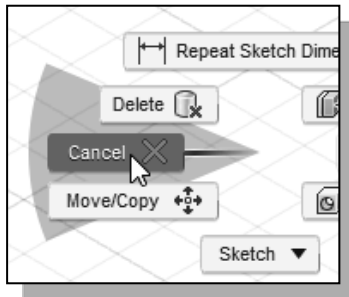
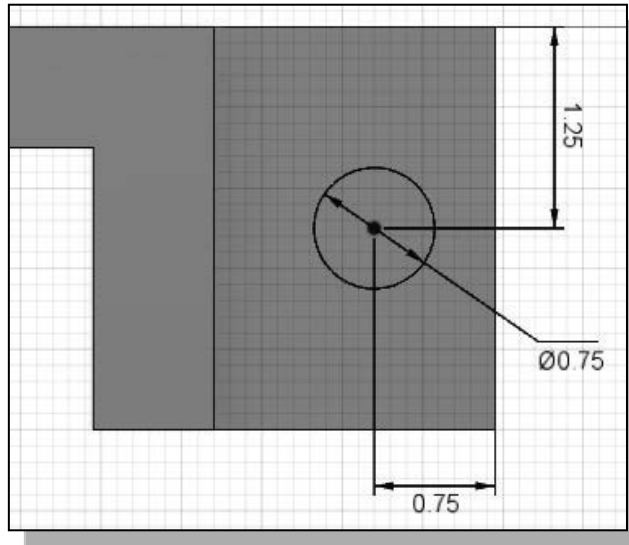

- Inside the graphics window, click once with the **right-mouse-button** to display the option menu. Select **Cancel** in the pop-up menu to end the Sketch Dimension command.



- Inside the graphics window, click once with the **right-mouse-button** to display the option menu. Select **Finish 2D Sketch** in the pop-up menu to end the Sketch option.



- In the *Create toolbar*, select the **Extrude** command by left-clicking on the icon.

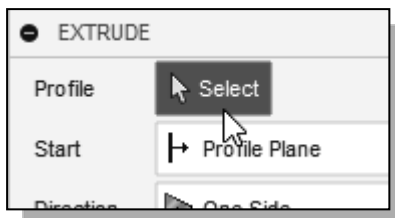

- In the *Extrude* pop-up control, the **Profile** button is activated; Autodesk Fusion 360 expects us to identify the profile to be extruded.

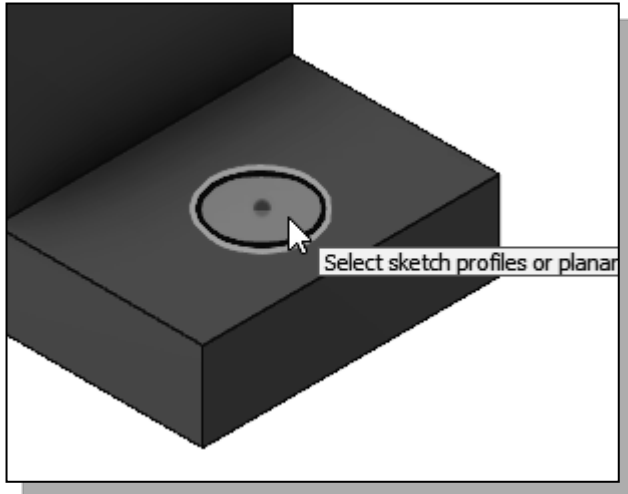

11. Click on the inside of the sketched circle to define the extrude profile as shown.

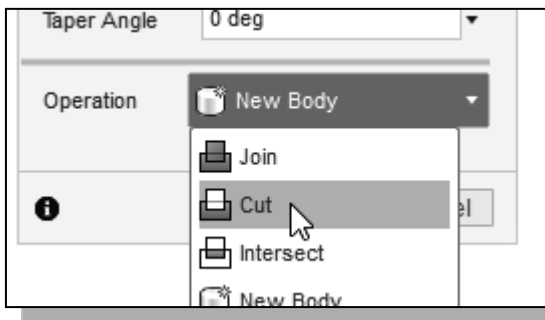

12. Select the **CUT** option in the *feature option* list to set the extrusion operation to *Cut*.

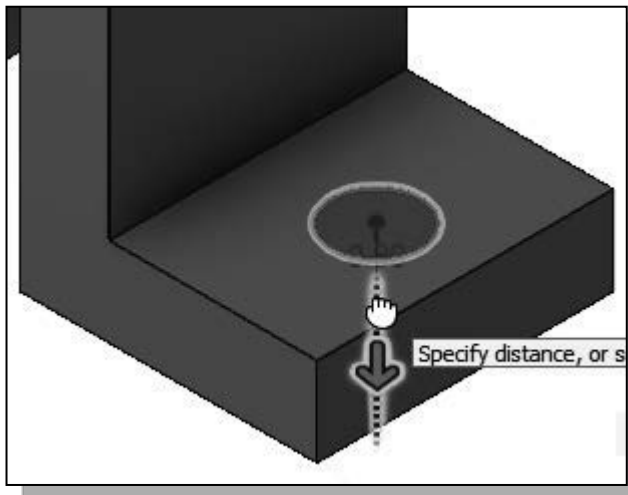

13. Move the cursor on top of the arrow; notice the dashed line appears.

14. Drag the arrow **downward**, with the left mouse button, to set the extrusion direction.

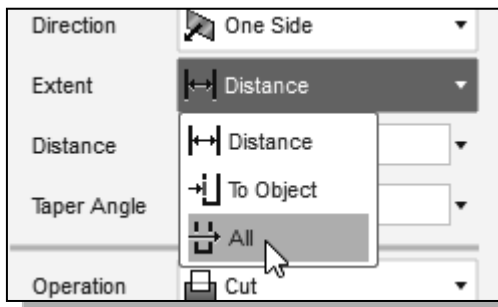

15. Set the *Extent* option to **Through All** as shown. The *All* option instructs the software to calculate the extrusion distance and assures the created feature will always cut through the full length of the model.

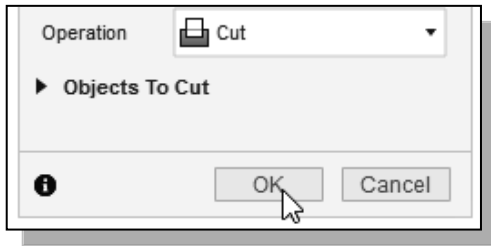

16. Click on the **OK** button to proceed with creating the extruded feature.

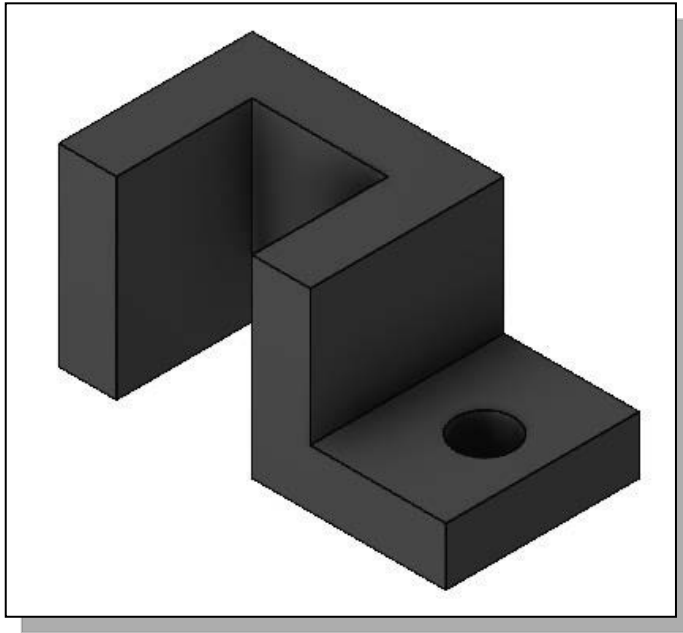

Step 4-3: Adding another Cut Feature

Next, we will create and profile a triangle, which will be used to create a cut feature that will be added to the existing solid object.

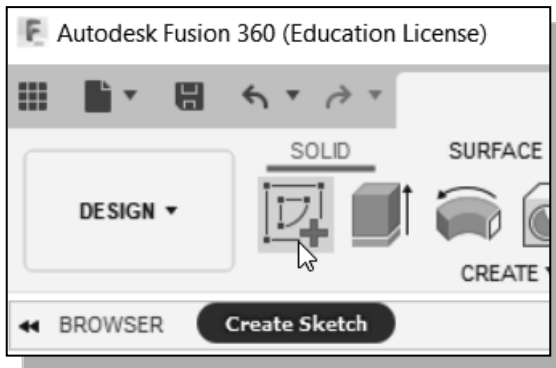

1. In the *3D Model* tab select the **Create Sketch** command by left-clicking once on the icon.

2. Pick the vertical face of the 3D solid model next to the horizontal section as shown.

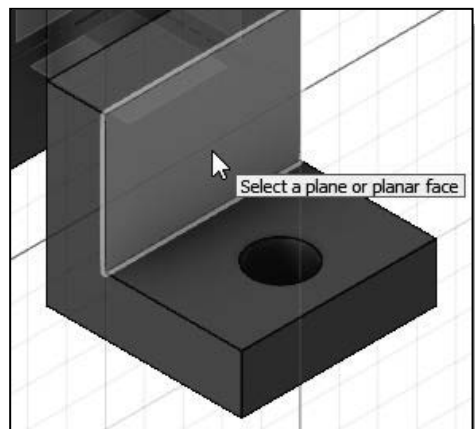

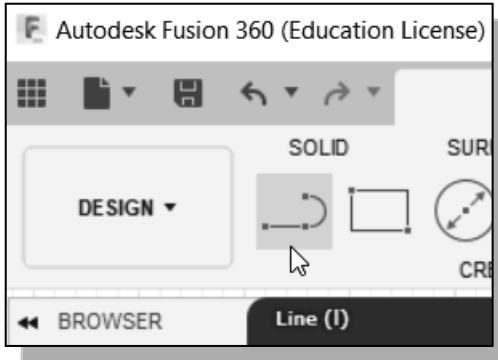

3. Select the **Line** command by clicking once with the **left-mouse-button** on the icon in the *Sketch* tab.

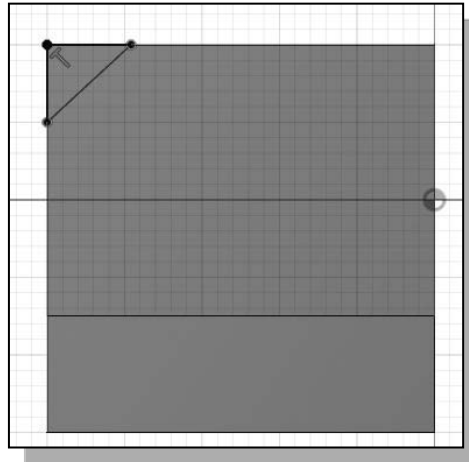

4. Start at the upper left corner and create **three line segments** to form a small triangle as shown.

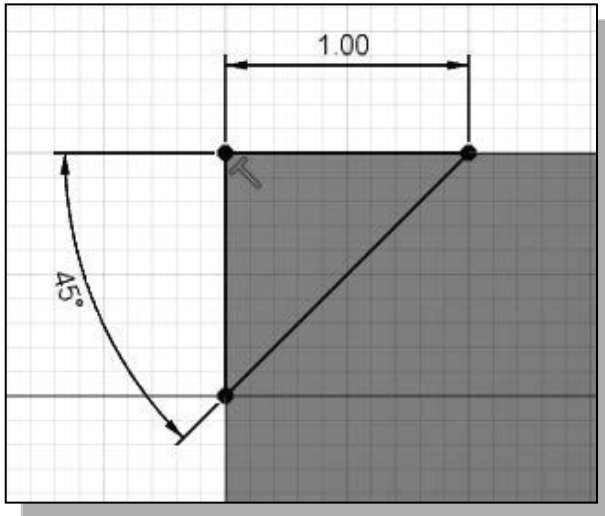

5. On your own, create and modify the two dimensions of the sketch as shown in the figure. (Hint: create the angle dimension by selecting the two adjacent lines and place the angular dimension inside the desired quadrant.)

6. Inside the graphics window, click once with the **right-mouse-button** to display the option menu. Select **Cancel** in the pop-up menu to end the Sketch Dimension command.

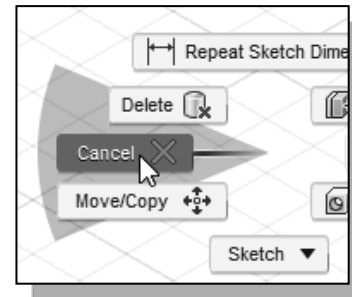

7. In the *ribbon toolbar area*, select **Finish Sketch** to end the Sketch option.



8. In the *Ribbon* toolbar, select the **Extrude** command by left-clicking the icon.

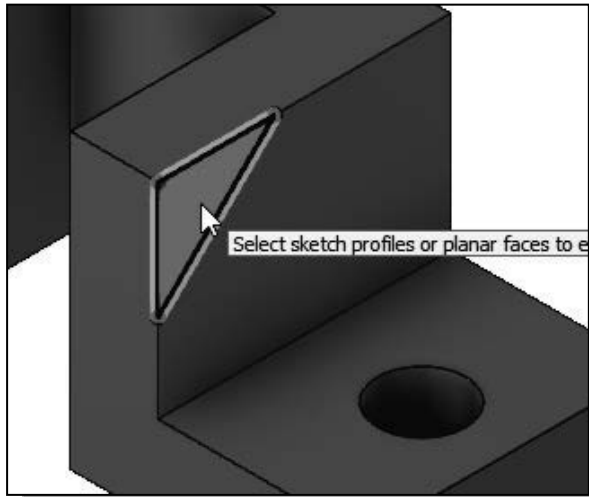

9. Click on the inside of the sketched circle to define the extrude profile as shown.

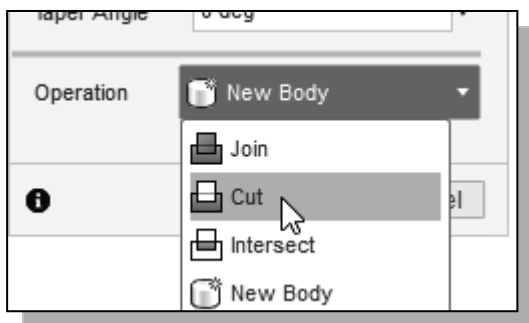

10. Select the **CUT** option in the *feature option* list to set the extrusion operation to *Cut*.

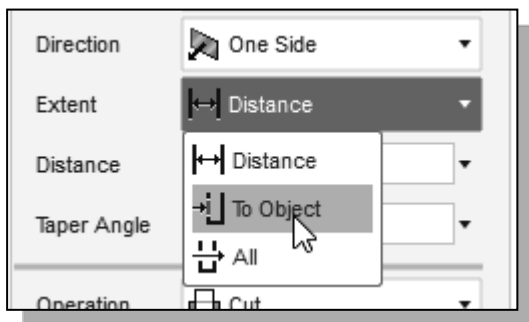

11. Set the *Extents* option to **To Object** as shown. The *To Object* option instructs the software to calculate the extrusion distance and assures the created feature will always cut through the proper length of the model.

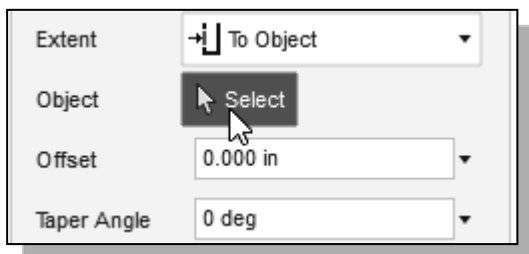

- Note the Select icon is activated and Fusion 360 expects us to select an object to set the termination of the extrude feature.

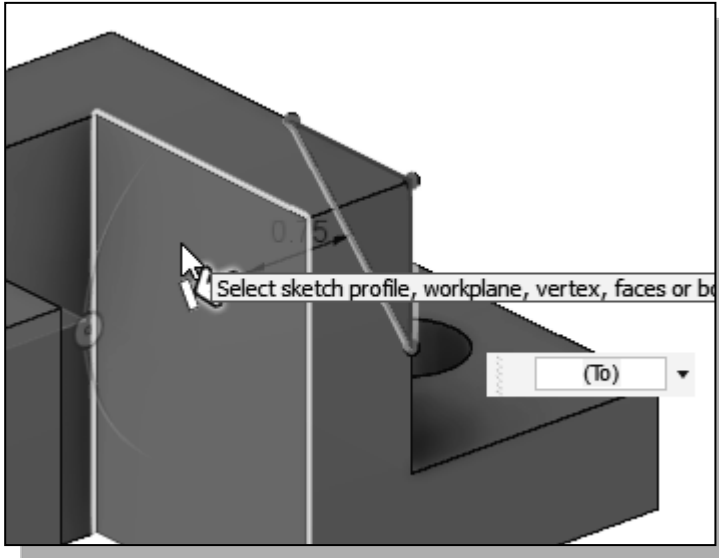

12. On your own, use the dynamic rotate function and select the back surface as shown.

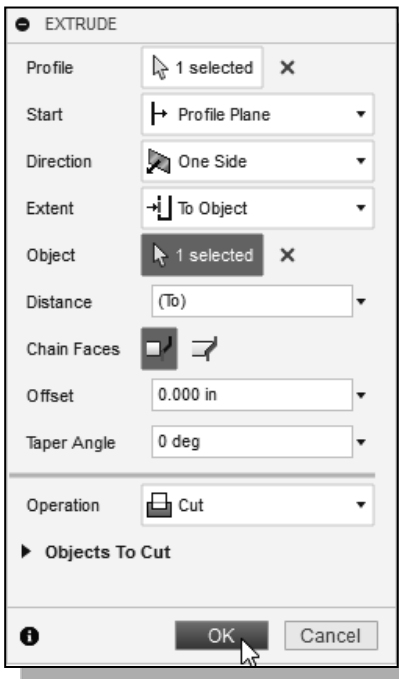

13. On your own, confirm the settings in the extrude dialog box as shown and click on the **OK** button to proceed with creating the extruded feature.

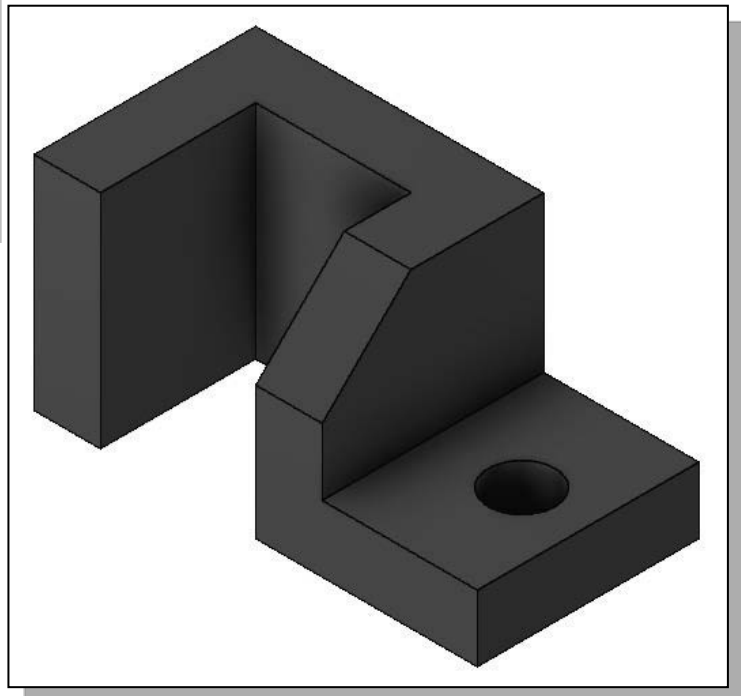

Save the Model

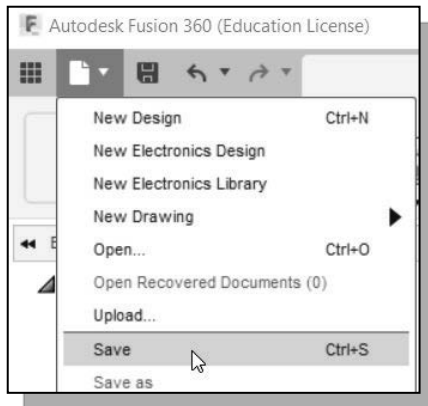

1. Select **Save** in the *Quick Access* toolbar, or you can also use the “**Ctrl-S**” combination (hold down the “**Ctrl**” key and hit the “**S**” key once) to save the part.



2. Expand the *option* list by clicking on the *down arrow* as shown.

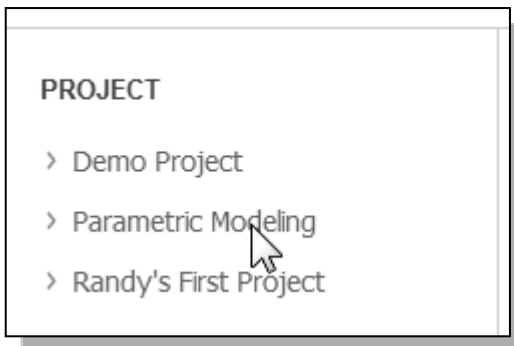

3. Select the Parametric Modeling Project by clicking once with the left mouse button.
4. Click **New Folder** to create a new subfolder.

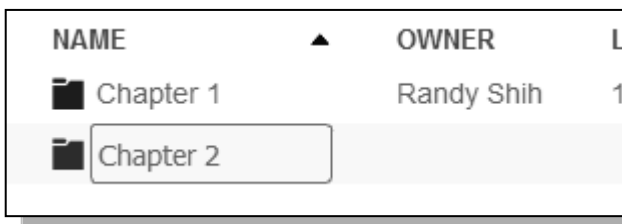

5. Enter **Chapter2** as the new folder name as shown.

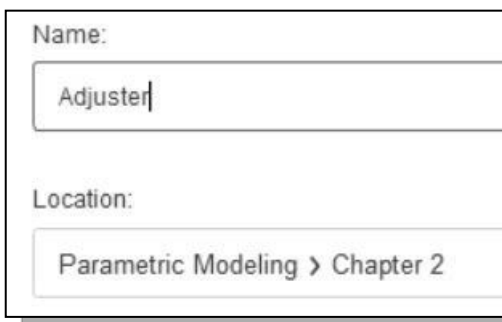

6. **Double-click** on the Chapter2 folder to open it.
7. In the *file name* editor box, enter **Adjuster** as the file name.
8. Click on the **Save** button to save the file.

Review Questions:

1. What is the first thing we should set up in Autodesk Fusion 360 when creating a new model?
2. Describe the general *parametric modeling* procedure.
3. Describe the general guidelines in creating *Rough Sketches*.
4. List two of the geometric constraint symbols used by Autodesk Fusion 360.
5. What was the first feature we created in this lesson?
6. How many solid features were created in the tutorial?
7. How do we control the size of a feature in parametric modeling?
8. Which command was used to create the last cut feature in the tutorial? How many dimensions do we need to fully describe the cut feature?
9. List and describe three differences between parametric modeling and traditional 2D Computer Aided Drafting techniques.

Exercises: Create and save the exercises in the Chapter2 folder.
 (All dimensions are in inches.)

1. **Inclined Support (Thickness: .5)**

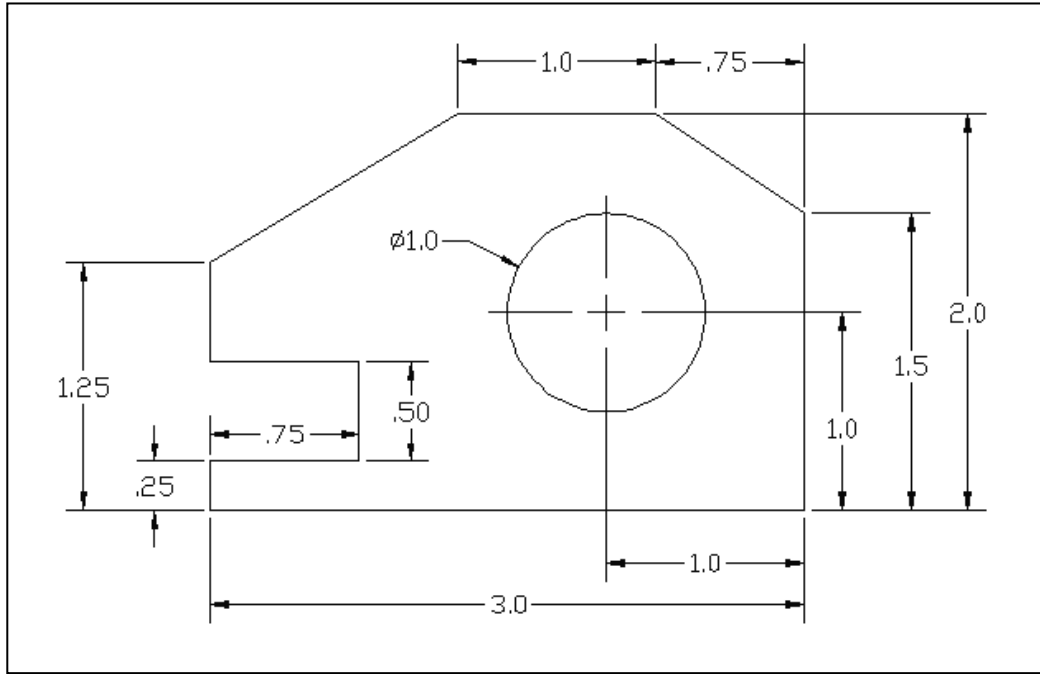

2. **Spacer Plate (Thickness: .125)**

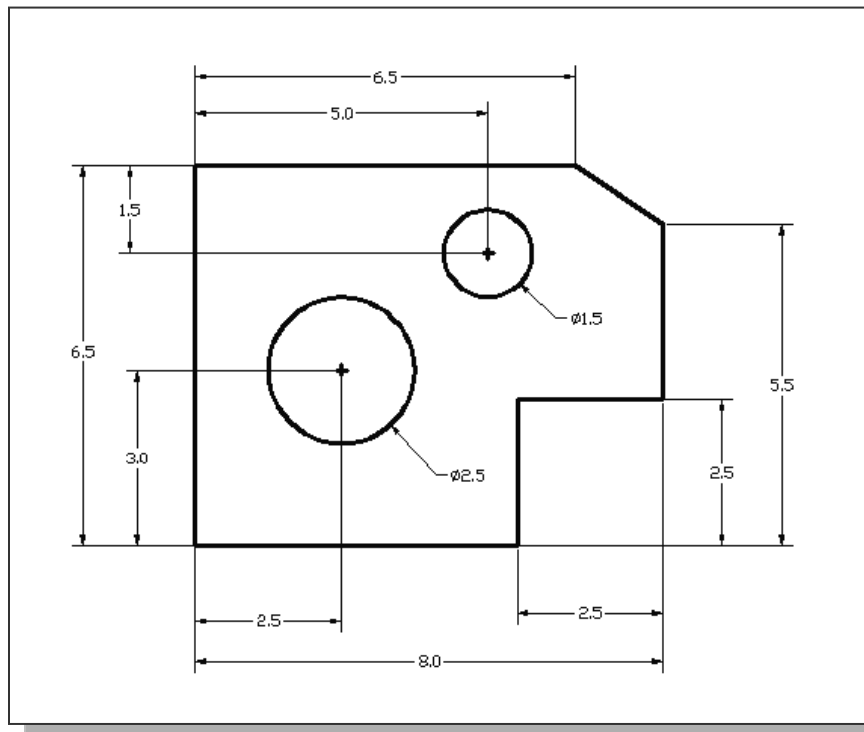

3. Positioning Stop

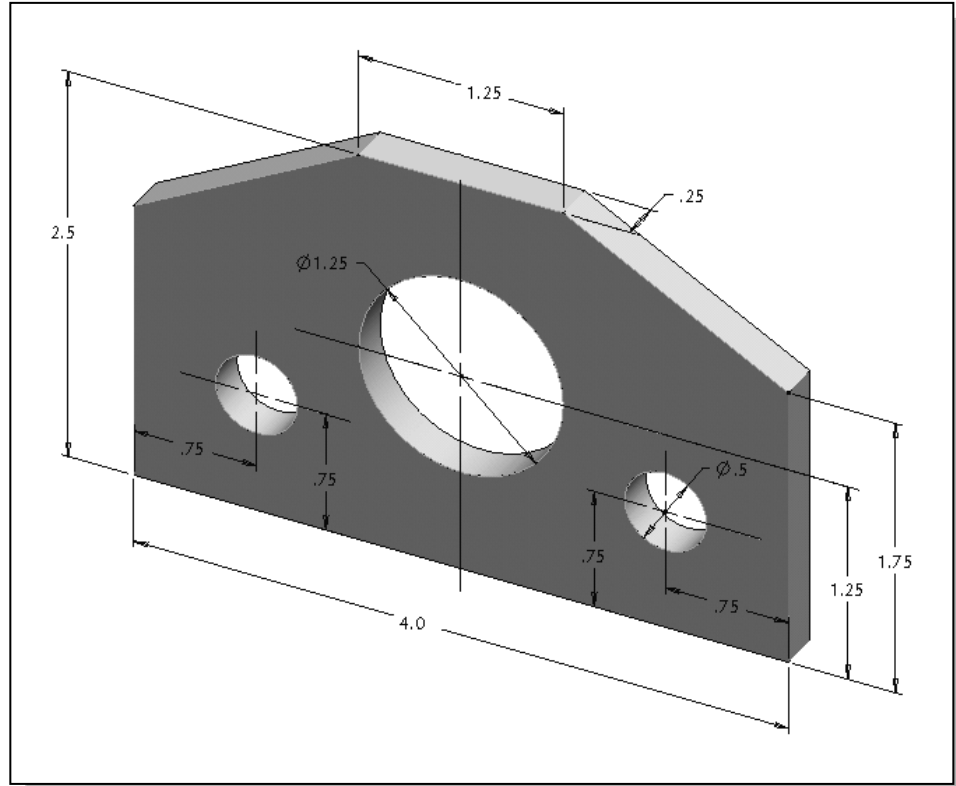

4. Guide Block

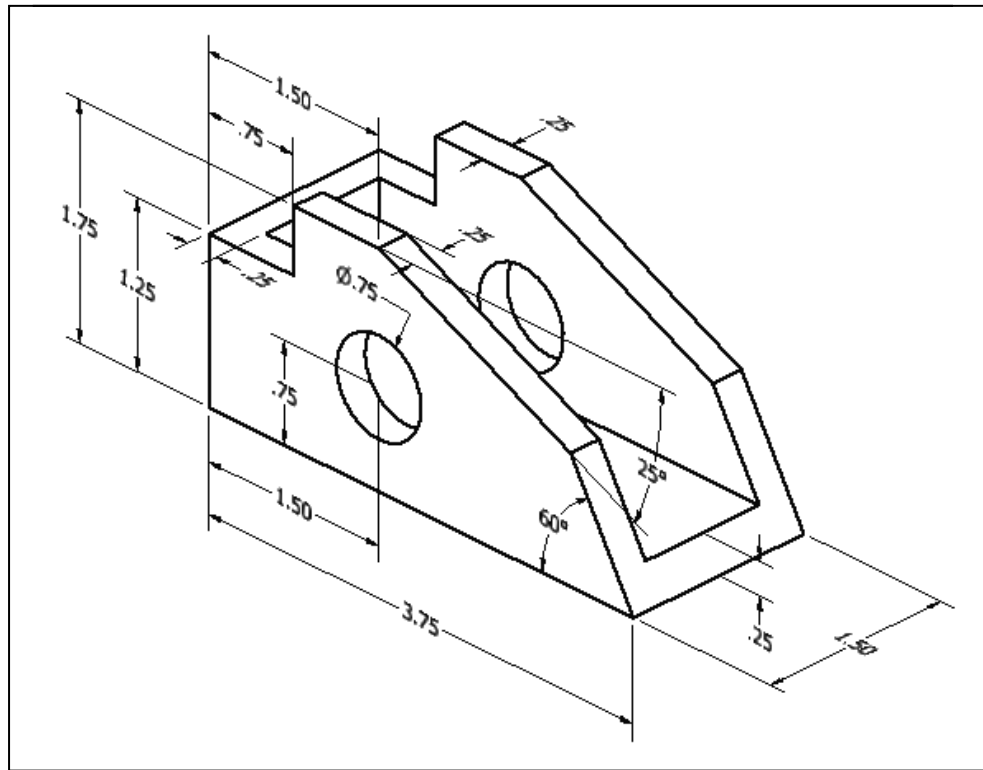

5. Slider Block

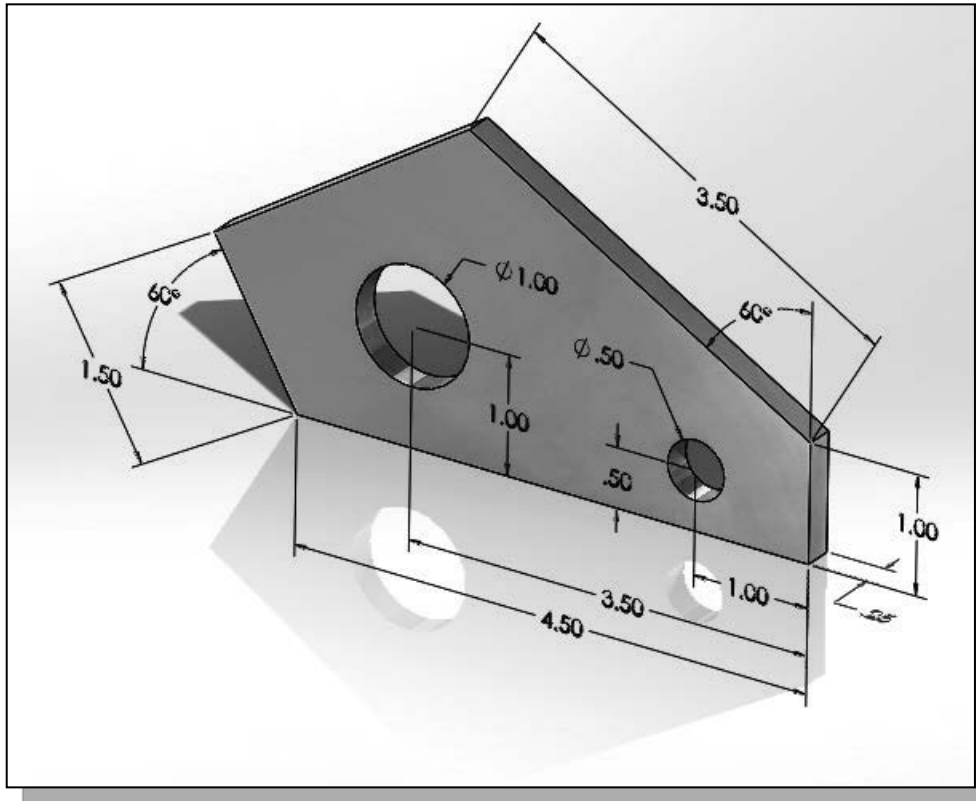

6. Coupler

