

AutoCAD® 2023 Tutorial

Second Level 3D Modeling

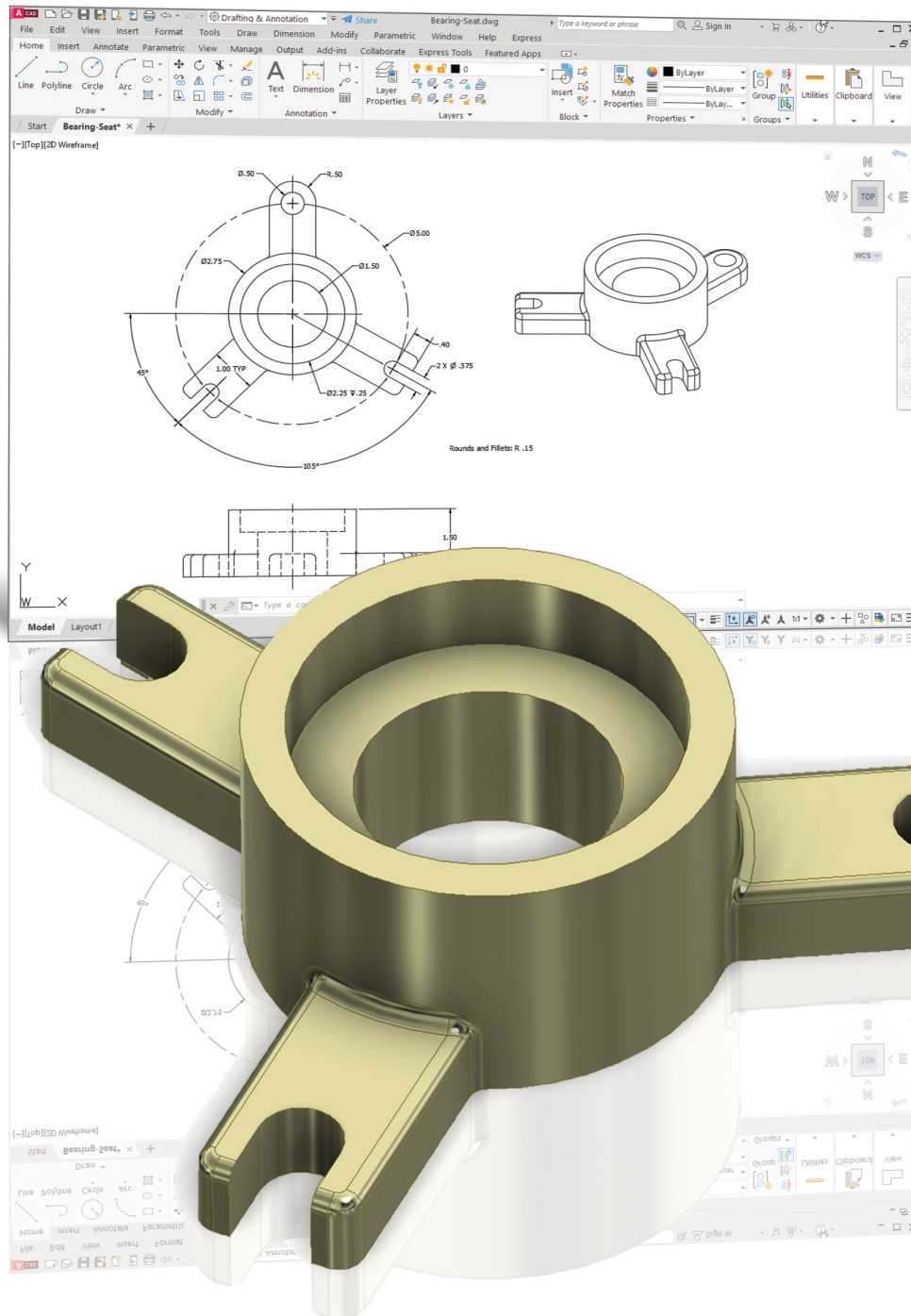

Randy H. Shih

Visit the following websites to learn more about this book:



[amazon.com](https://www.amazon.com)

[Google books](https://books.google.com)

[BARNES & NOBLE](https://www.barnesandnoble.com)

Chapter 3

UCS, Viewports and Wireframe Modeling

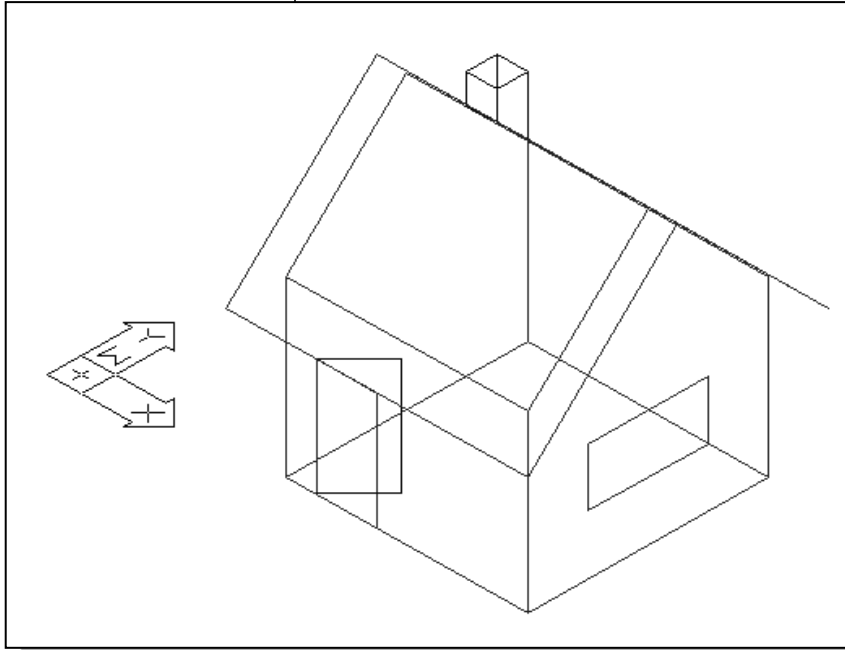

Learning Objectives



- ◆ Understand the Use of UCS on More Complex Designs
- ◆ Display and Orient 3D Views
- ◆ Apply and Expand the Basic Wireframe Construction Techniques
- ◆ Use Additional Tools to Assist the Creation of 3D Wireframe Models
- ◆ Use the Named Views Option

Introduction

In the previous chapter, we examined some of the basic techniques to create 3D wireframe models. Again, a wireframe model is a skeletal description of a 3D object. There are no surfaces in a wireframe model; it consists only of points, lines, and curves that describe the edges of the object.

In this chapter, we will further discuss the techniques and wireframe modeling tools available in AutoCAD. Instead of creating the corners and edges of wireframe models by entering the precise 3D coordinates, the use of construction lines and referencing techniques are illustrated. The construction of edges in 3D space can be simplified by using the *AutoCAD User Coordinate System*. We will also use the multiple viewports option, which is available in most CAD systems, to aid the construction of 3D wireframe models.

It is important to point out that most of the construction tools used in creating 2D designs, such as *Object Snap* and *Polar Tracking*, as well as the *Copy*, *Mirror*, and *Array* commands, are also applicable to the constructions of 3D wireframe models.

The V-Block Design

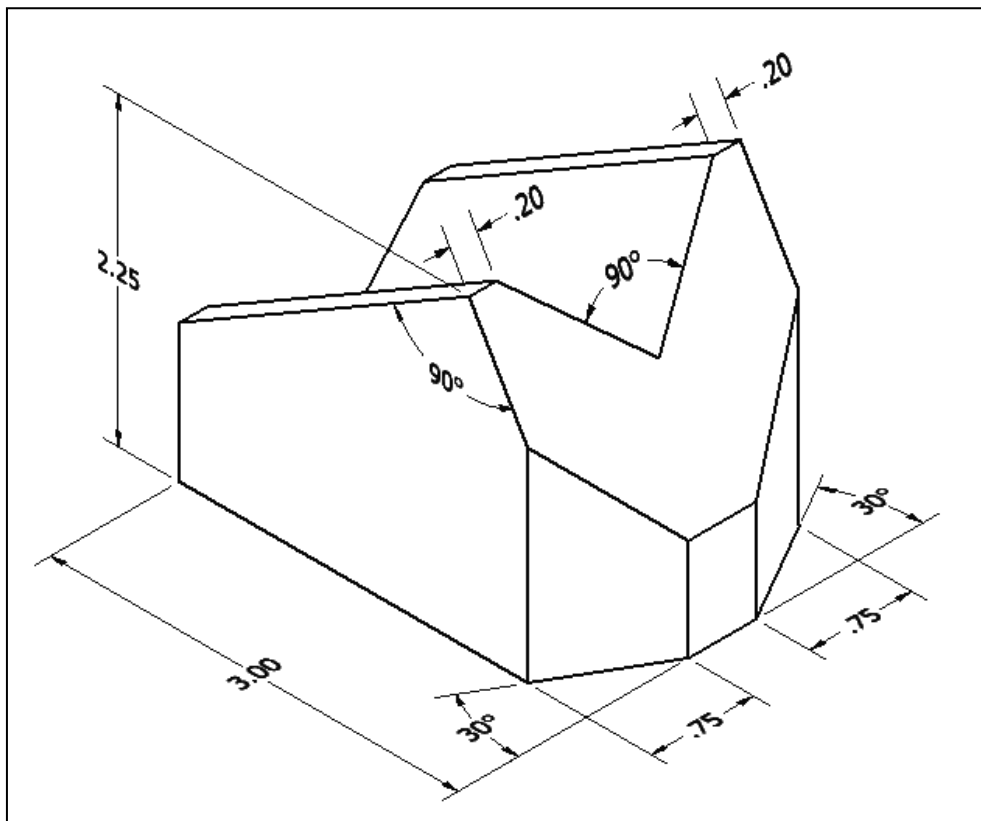

Starting Up AutoCAD 2023

1. Select the **AutoCAD 2023** option on the *Program* menu or select the **AutoCAD 2023** icon on the *Desktop*.



2. In the *Startup* window, select **Start from Scratch**.
3. In the *Default Settings* section, pick **Imperial (feet and inches)** as the drawing units.

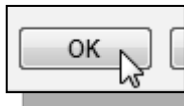

4. Pick **OK** in the *Startup* dialog box to accept the selected settings.

3D Modeling Workspace

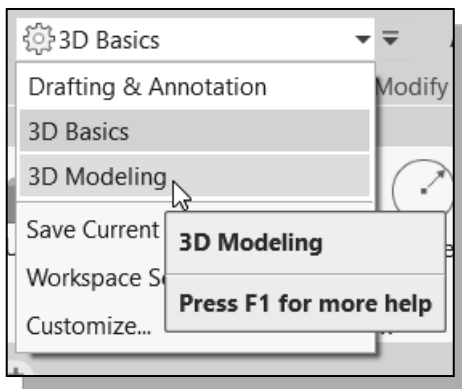

1. Click on the workspaces list in the *Quick Access* toolbar and choose to use the **3D Modeling** workspace as shown.
2. On your own, switch **on** the **Menu Bar**.
➤ Notice the different 3D modeling toolbars available in the *Ribbon* toolbar area as shown.

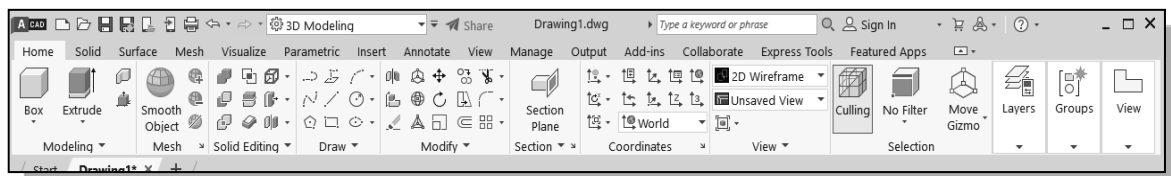

Layers Setup

1. In the *Menu Bar*, select **[Tools] → [Toolbars] → [AutoCAD] → [Layers]**.

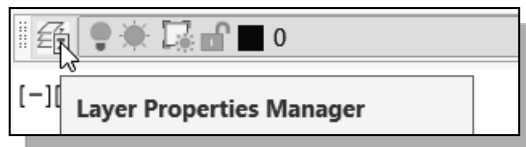
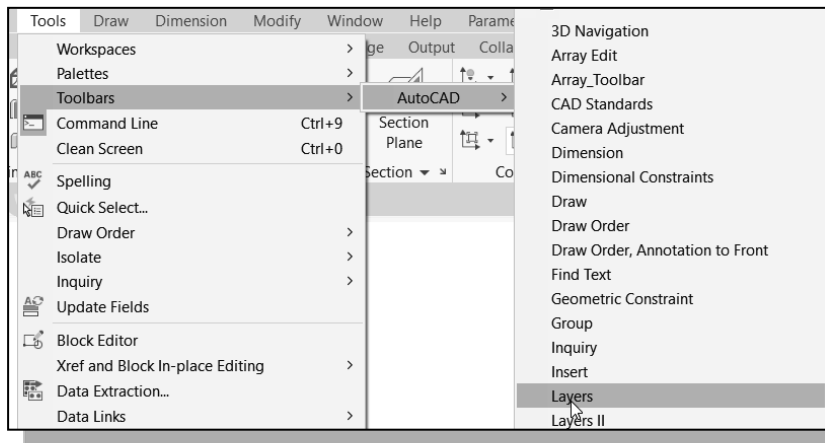

2. Click **Layer Properties Manager** in the *Layers* toolbar.

- ❖ In AutoCAD, we always construct entities on a layer. It may be the default layer or a layer that we create. Each layer has associated properties such as the visibility setting, color, linetype, lineweight, and plot style.



3. Click on the **New Layer** button. Notice a layer is automatically added to the list of layers.

4. Create **two new layers** with the following settings:

<i>Layer</i>	<i>Color</i>	<i>Linetype</i>	<i>Lineweight</i>
Construction	Grey	Continuous	Default
Object	Cyan	Continuous	0.30mm

5. Highlight the layer **Construction** in the list of layers.

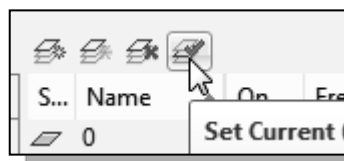

6. Click on the **Set Current** icon to set layer **Construction** as the *Current Layer*.

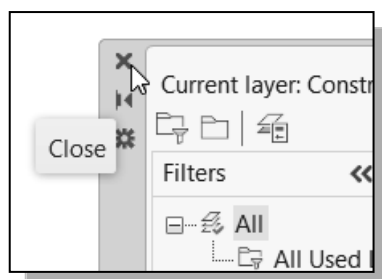

7. Click on the **Close** button to accept the settings and exit the *Layer Properties Manager* dialog box.
8. In the *Status Bar* area, turn **ON** the *Grid Display*, *Polar Tracking*, *Object Snap*, *Object Snap Tracking*, *Dynamic Input* and *Lineweight* options.

Create the Rectangular Base of the Design

We will first use construction geometry to define the outer edges of the design.

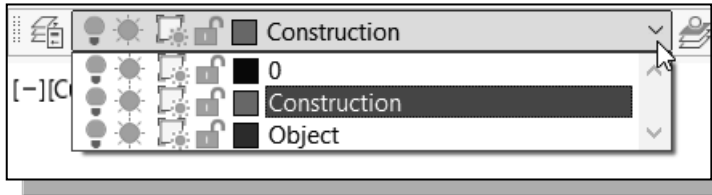

1. In the *Layer Control* box, confirm that layer *Construction* is set as the *Current Layer*.

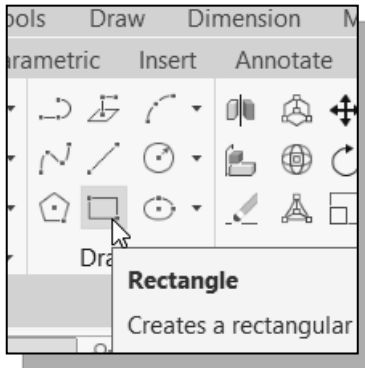

2. Select the **Rectangle** icon in the *Draw* toolbar. In the command prompt area, the message “*Specify first corner point or [Chamfer/Elevation/Fillet/ Thickness/ Width].*” is displayed.
3. Place the first corner point of the rectangle near the lower left corner of the screen. Do not be overly concerned about the actual coordinates of the location; the drawing space is as big as you can imagine.

4. We will create a 3" × 2" rectangle by entering the coordinates of the second corner using the relative coordinates input method.

Specify other corner point or [Dimension]: @3,2 [ENTER].

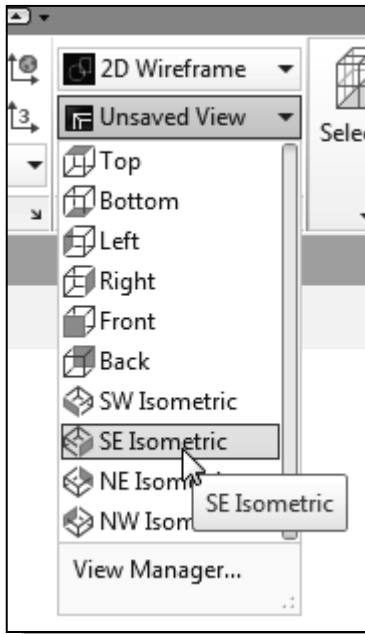

5. In the *View* panel, select:

[Unsaved View] → [SE Isometric]

- Notice the orientation of the sketched 2D rectangle in relation to the displayed AutoCAD user coordinate system. By default, the 2D sketch-plane is aligned to the XY plane of the world coordinate system.

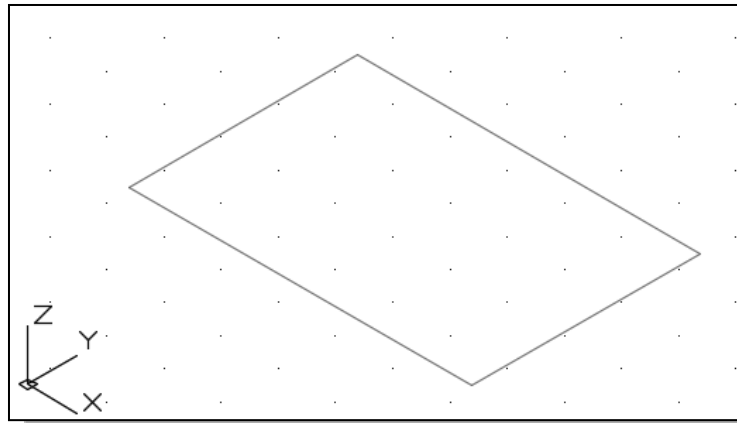

Create a Wireframe Box

Next, we will use the Copy command to define the 3D boundary of the design.

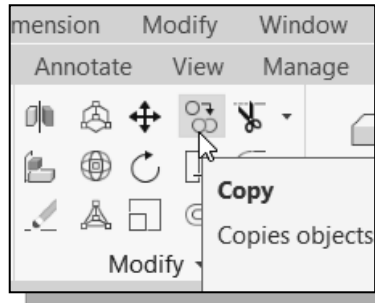

1. Click on the **Copy Object** icon in the *Modify* toolbar.
 2. In the command prompt area, the message “*Select objects:*” is displayed. Pick any edge of the sketched rectangle.
 3. Inside the graphics window, right-click once to accept the selection.
 4. In the command prompt area, the message “*Specify base point or displacement, or [Multiple]:*” is displayed. Pick any corner of the sketched rectangle as a base point to create the copy.
 5. In the command prompt area, the message “*Specify second point of displacement or <use first point as displacement>:*” is displayed.
Enter **@0,0,2.25 [ENTER]**.
- Note that the three values represent the distance measured in the X, Y and Z directions relative to the current UCS.

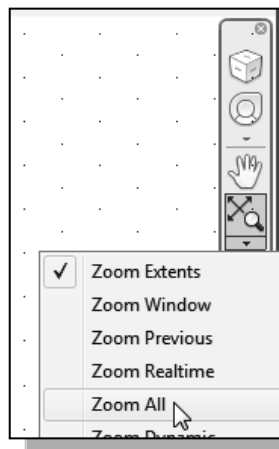

6. Use the **Zoom All** command, in the *View Display* toolbar, to adjust the display.
7. On your own, use the **Line** command to create the four lines connecting the four-corners of the two rectangles as shown.

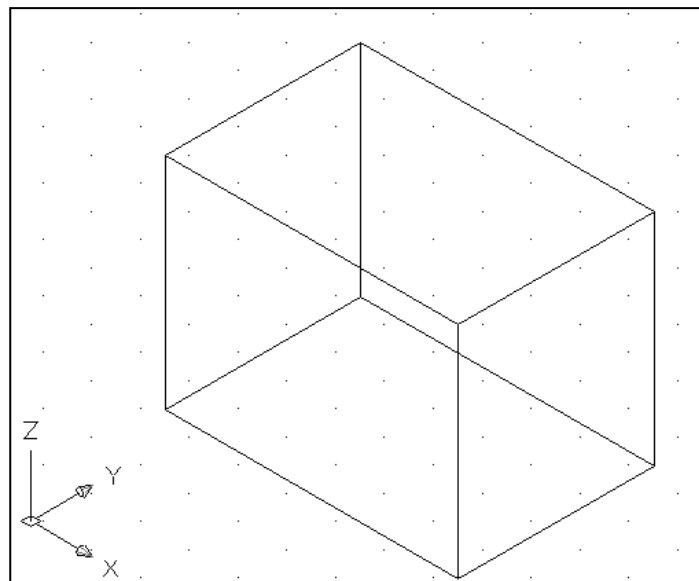
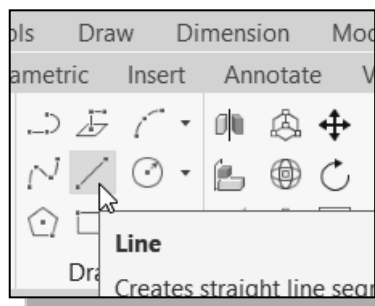

Using the View and UCS Toolbars

1. In the *Menu Bar*, select **[Tools] → [Toolbars] → [AutoCAD]**.

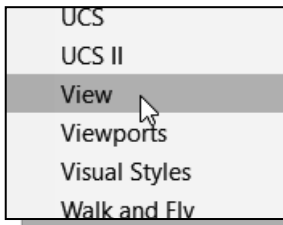
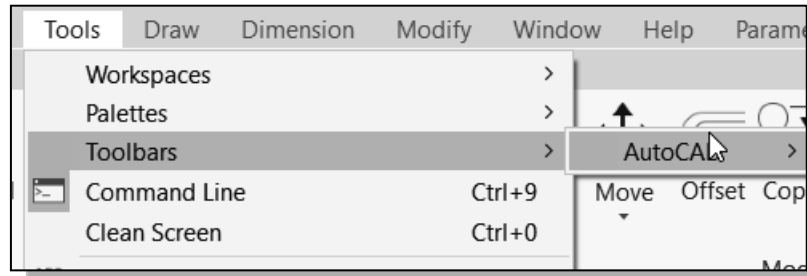

2. Select **View**, with the left-mouse-button, to display the *View* toolbar on the screen.

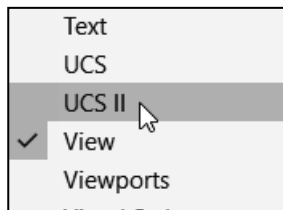

3. Move the cursor to the *Standard* toolbar area and **right-click** on any icon of the *Standard* toolbar to display a list of toolbar menu groups.
4. Select **UCS II**, with the left-mouse-button, to display the *UCSII* toolbar on the screen.

- The options available in *UCS II* toolbar allow us to quickly align the UCS to the preset standard 2D views.

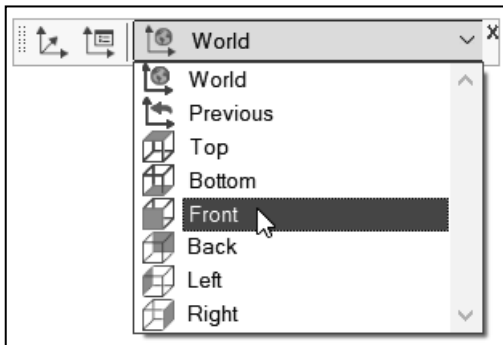

5. Note that the current *UCS* is aligned to the *World Coordinate System*. Select **Front** in the *UCS II* toolbar as shown.

- Note that the UCS has been adjusted and it is now aligned parallel to the front view of the wireframe box as shown in the figure.

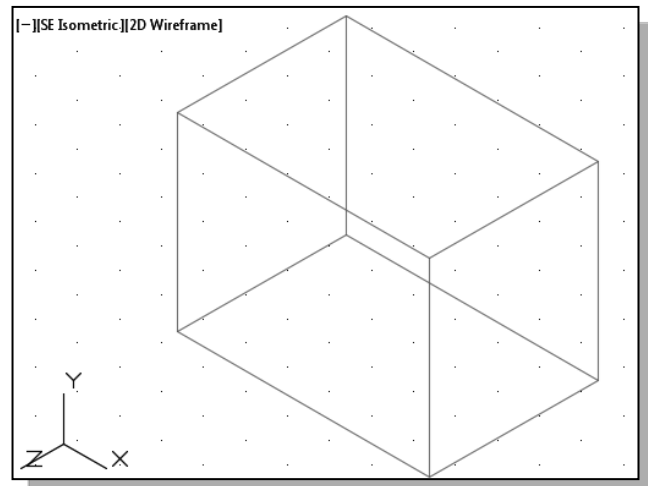

Create Construction Lines in the Front View

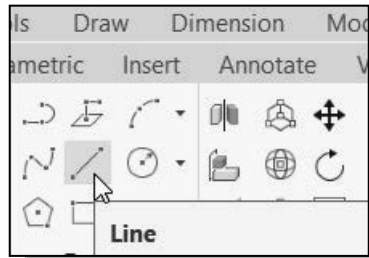

1. Select the **Line** command icon in the *Draw* toolbar. In the command prompt area, the message “*_line Specify first point.*” is displayed.

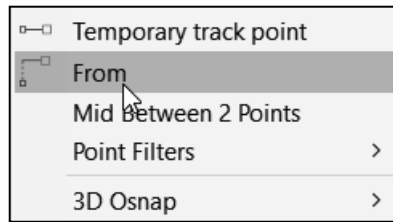

2. Inside the graphics window, hold down the [**SHIFT**] key and **right-click** once to bring up the *Object Snap* shortcut menu.

3. Select the **From** option in the pop-up window.

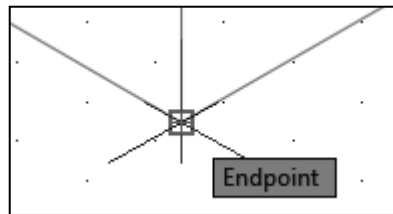

4. Pick the lower right corner of the bottom horizontal line in the front view as the base point.

5. In the command prompt area, the message “*Specify next point or [Undo]:*” is displayed. Enter **@0,0.75 [ENTER]**.

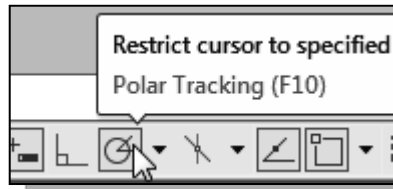

6. We will set up the *Polar Tracking* option to assist the creation of the next corner. **Right-click** once on the *POLAR* Tracking option located at the bottom of the graphics window.

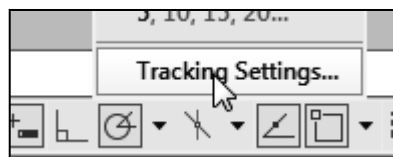

7. In the option menu, select **Settings** by clicking once with the left-mouse-button.

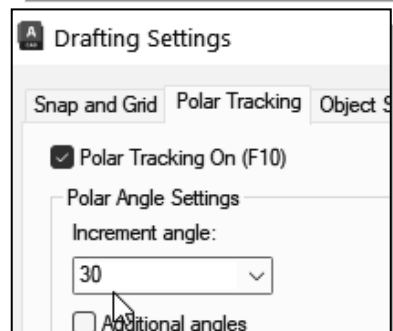

8. In the *Drafting Settings* dialog box, set the *Polar Increment Angle* setting to **30** degrees.

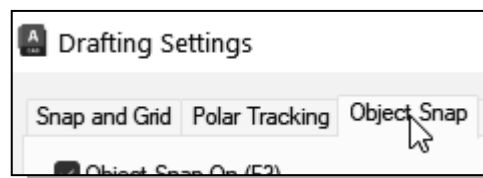

9. Click on the **Object Snap** tab to switch to the *Object Snap* option settings.

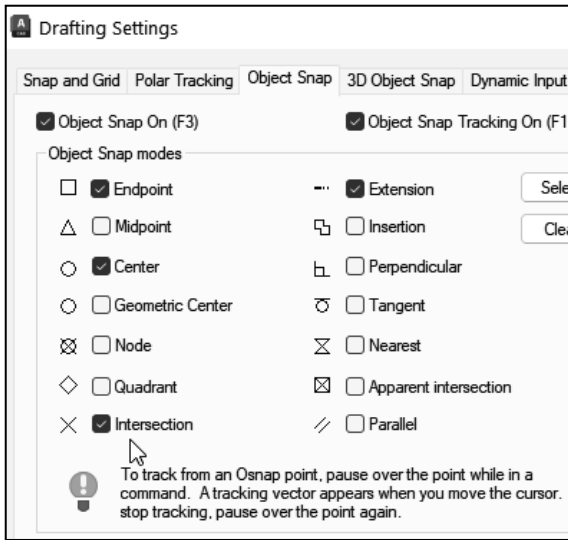

10. Confirm that the *Intersection* and *Extension* options are switched *ON* as shown.

11. Click on the **OK** button to accept the settings.

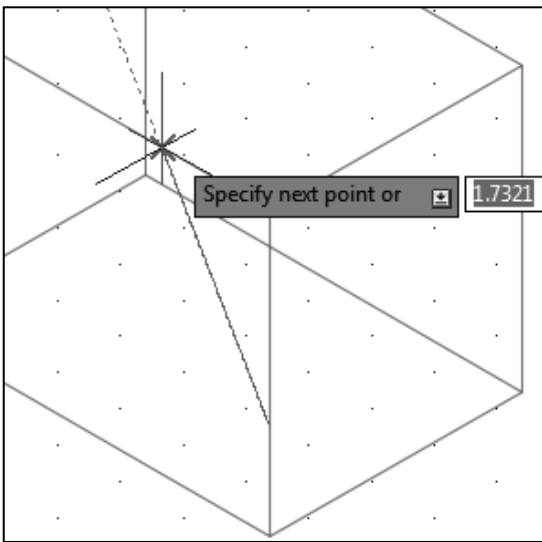
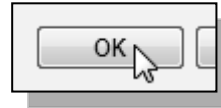

12. In the command prompt area, the message “*Specify next point or [Undo]:*” is displayed. Using the *Polar Tracking* option (30 degrees increment), create a line as shown in the figure.

13. Move the cursor near the left vertical edge of the front view and create the second line perpendicular to the last line we created.

14. Inside the graphics window, **right-click** to activate the option menu and select **Enter** with the left-mouse-button to end the **Line** command.

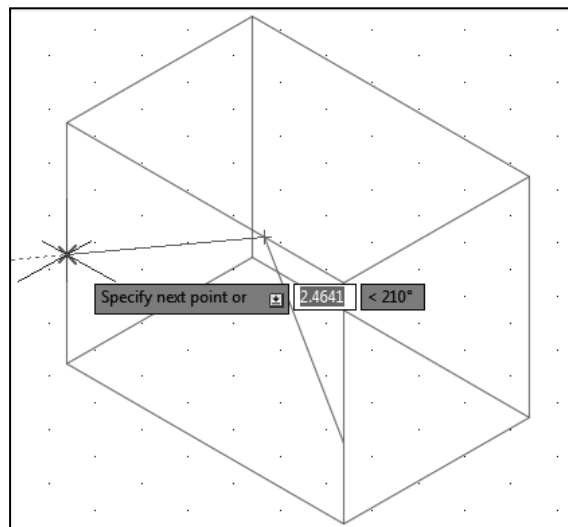
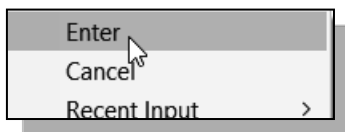

Copy Objects in the Negative Z Direction

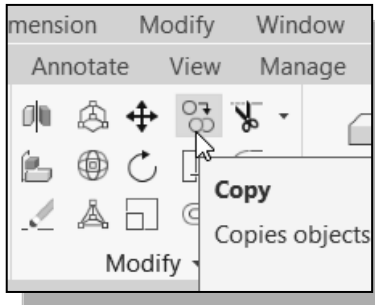

1. Click on the **Copy Object** icon in the *Modify* toolbar.
2. In the command prompt area, the message “*Select objects:*” is displayed. Pick the two edges we just created.
3. Inside the graphics window, right-click once to accept the selection.
4. In the command prompt area, the message “*Specify base point or displacement, or [Multiple]:*” is displayed. Pick any **corner** of the wireframe model to use as a base point to create the copy.
5. In the command prompt area, the message “*Specify second point of displacement or <use first point as displacement>:*” is displayed.

Enter **@0,0,-2.0 [ENTER]**.

6. Note that the negative value represents the distance measured in the negative *Z* direction relative to the current UCS.
7. On your own, create three lines to connect the corners of the two sets of lines we just created, as shown below.

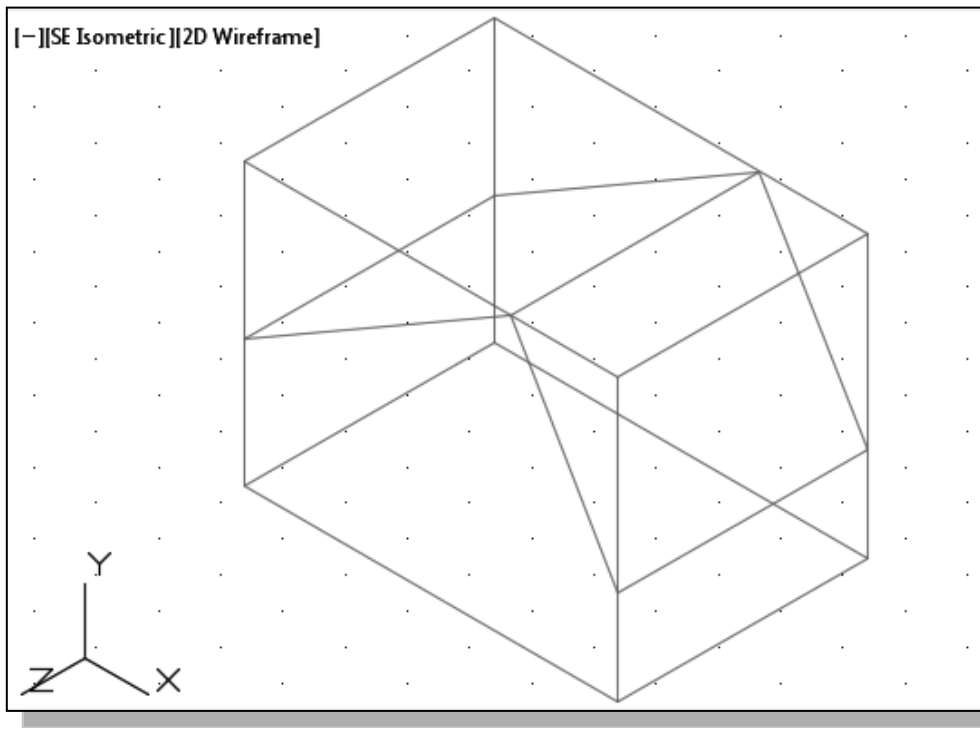

Create an Inclined Line at the Base of the Model



1. Select **Top** in the *UCS II* toolbar as shown.

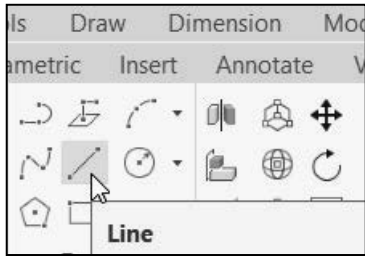

2. Select the **Line** command icon in the *Draw* toolbar. In the command prompt area, the message “*_line Specify first point:*” is displayed.

3. Inside the graphics window, hold down the **[SHIFT]** key and **right-click** once to bring up the *Object Snap* shortcut menu.

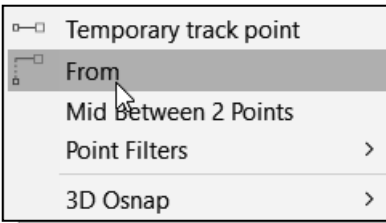

4. Select the **From** option in the pop-up window.

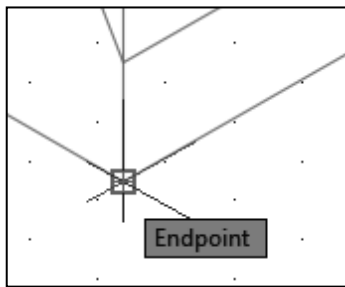

5. Pick the lower right corner of the bottom horizontal line as the base point as shown in the figure.

6. We will place the first point above the selected corner. Enter **@0,0.75 [ENTER]**.

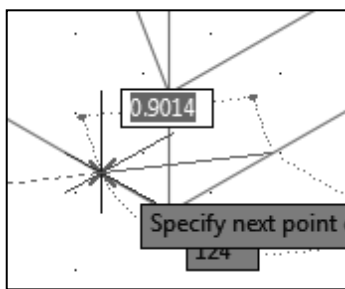

7. In the command prompt area, the message “*Specify next point or [Undo]:*” is displayed. Using the *Polar Tracking* option (30 degrees increment), create a line as shown in the figure.

8. Inside the *graphics window*, **right-click** to activate the option menu and select **Enter** with the left-mouse-button to end the *Line* command.

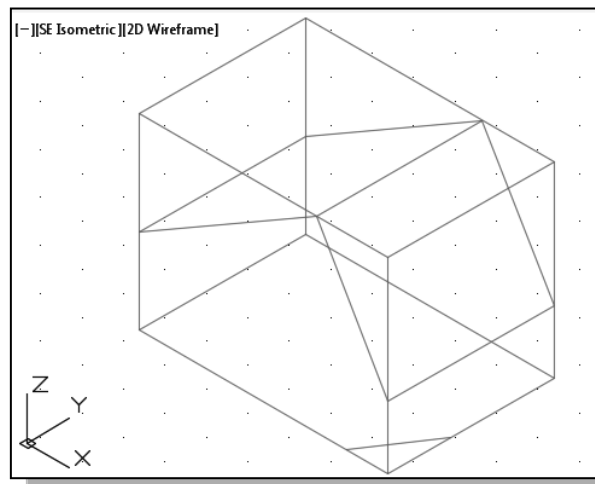
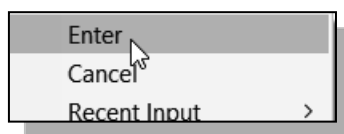

- On your own, use the **Copy** and **Line** commands to create additional edges so that the wireframe model appears as shown below.

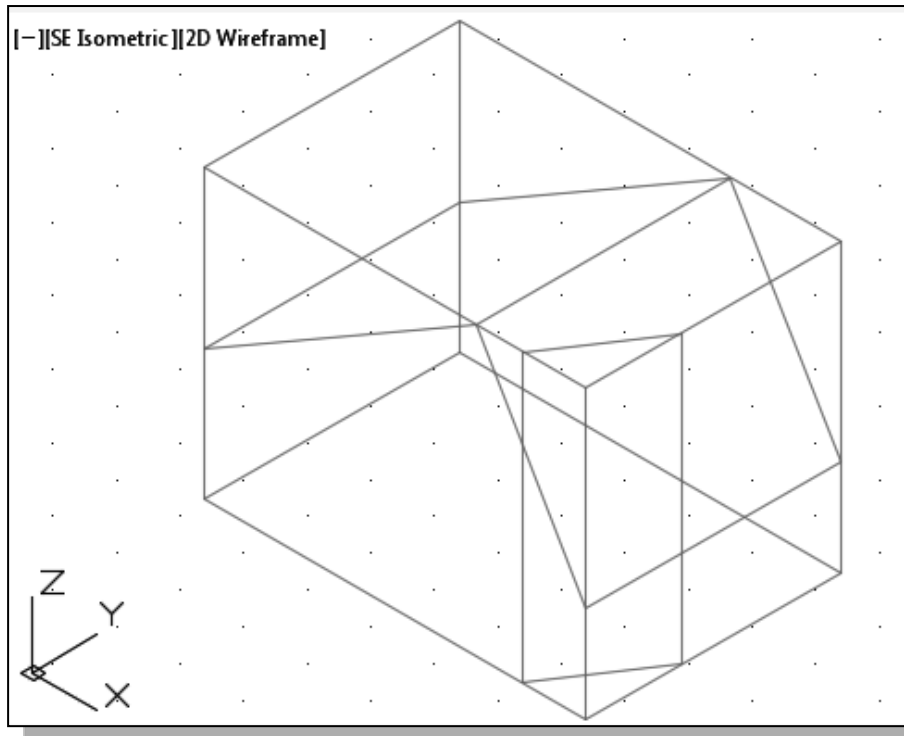

Create Object Lines

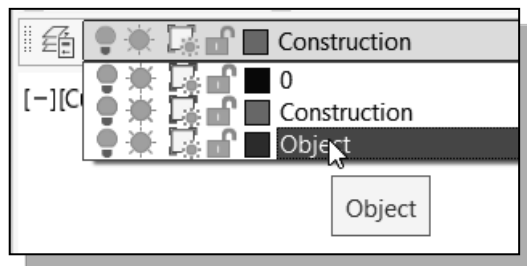

1. On the *Object Properties* toolbar, choose the **Layer Control** box with the left-mouse-button.
2. Move the cursor over the name of layer **Object**; the tool tip “*Object*” appears.

3. **Left-click once** on the layer name; now layer *Object* is set as the *Current Layer*.

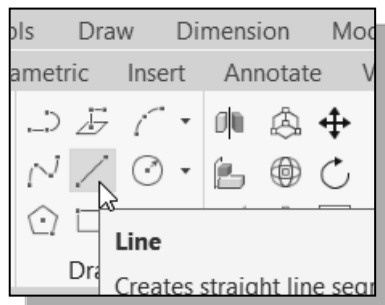

4. Select the **Line** command icon in the *Draw* toolbar. In the command prompt area, the message “*_line Specify first point:*” is displayed.

5. Pick the lower left corner of the bottom of the wireframe model as the starting point and create the four line segments as shown.

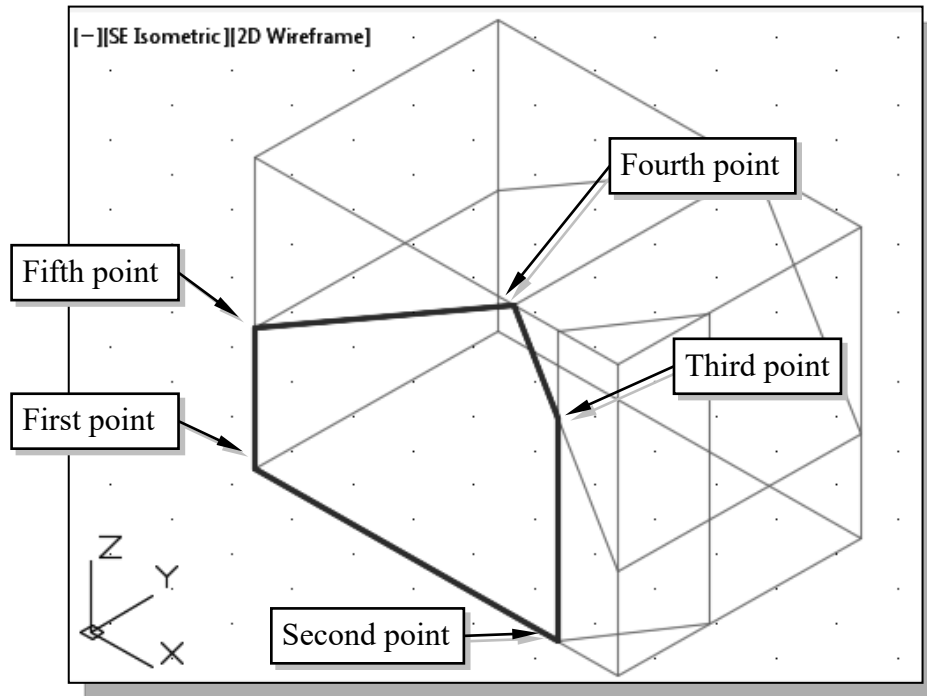

- Note that even though the UCS is aligned to the base plane of the model, the *Object Snap* option enables us to select points on the front plane of the model.
- On your own, create three additional lines representing the edges of the inclined face of the design as shown.

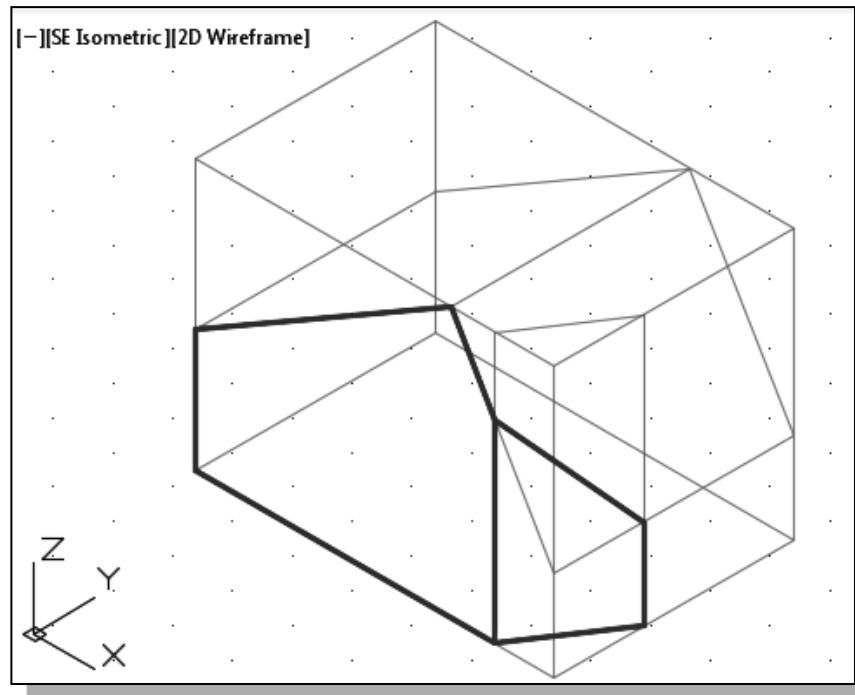

Multiple Viewports

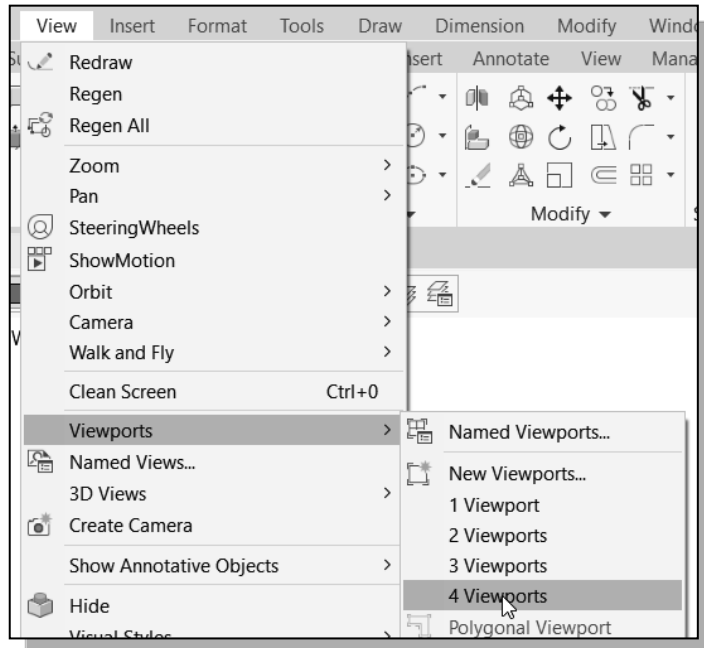

1. In the *Menu Bar*, select:

[View] → [Viewports] → [4 Viewports]

- AutoCAD allows us to display different **VIEWS** of the model simultaneously. Only one viewport is activated at one time. The viewport with the darker border is the active viewport. Move the cursor inside each viewport and notice the different cursor-display inside the active viewport.

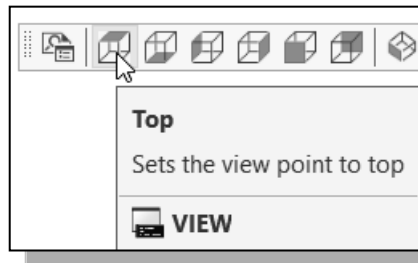

2. Activate the **top left viewport** by left-clicking once inside the viewport.
3. Select the **Top** view in the *View* toolbar to change the display of the viewport.

4. On your own, repeat the above steps and use the **Realtime Zoom** command to set and adjust the displays of the viewports as shown below.

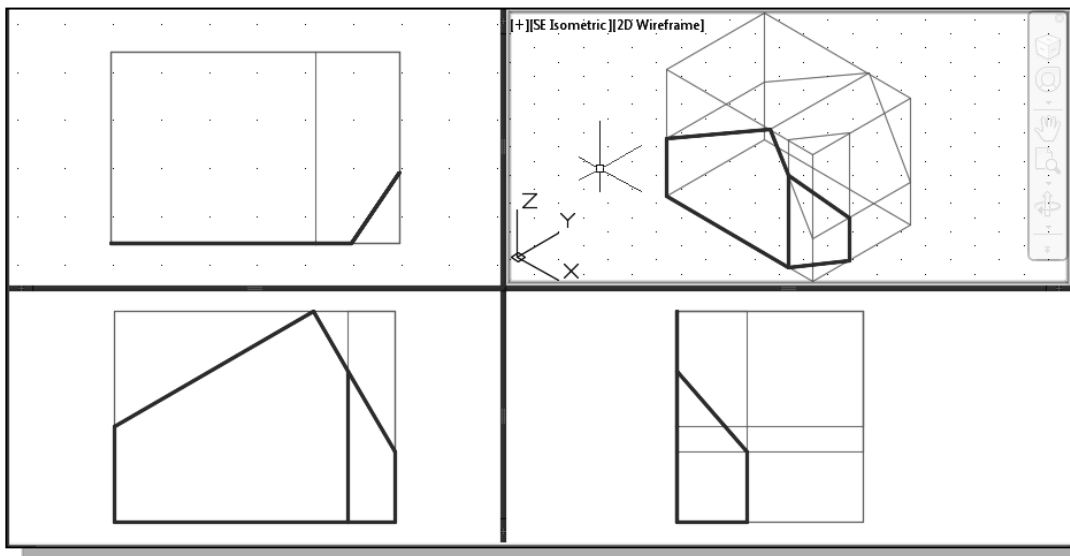

- Note that the displayed UCS icons at the lower left corner of each viewport correspond to the orientation of the wireframe model in each viewport.

Use the Mirror Command

1. Activate the top left viewport by left-clicking once inside the viewport.
2. *Pre-select* all the objects in the active viewport by using a selection window.

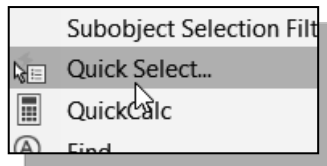
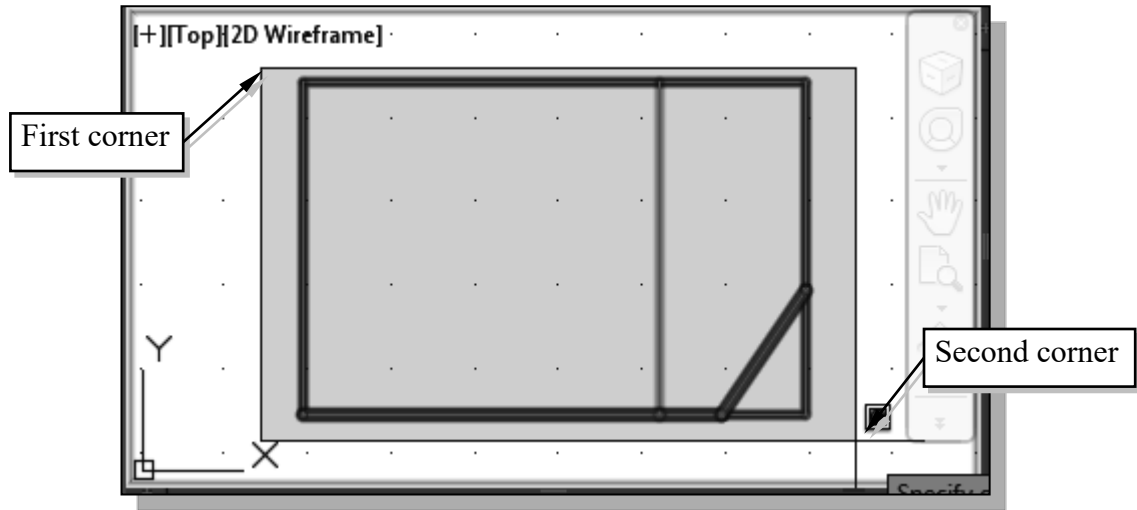

3. Inside the *active viewport*, **right-click** to bring up the pop-up option menu and select the **Quick Select** option.

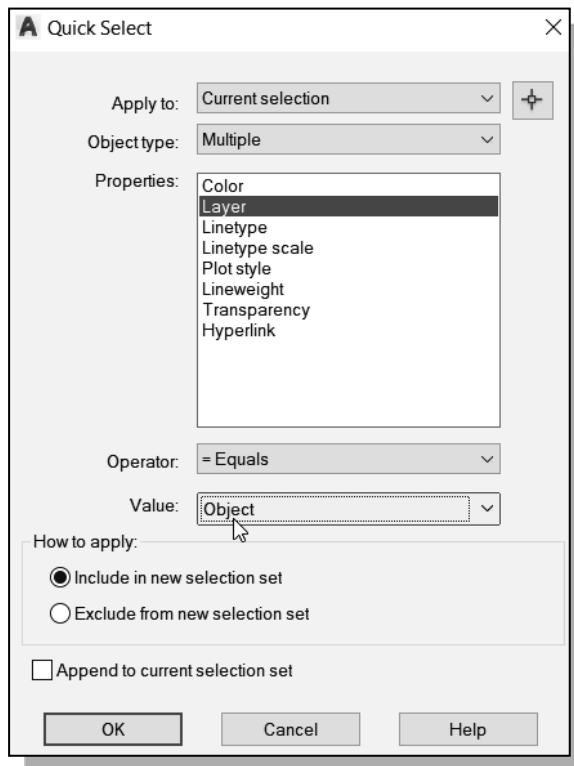

4. In the *Quick Select* dialog box, select **Layer** from the *Properties* list.
 5. Set the *Value* box to **Object**.
 6. In the *How to apply* section, confirm the **Include in new selection set** option is selected.
 7. Switch *OFF* the **Append to current selection set**.
 8. Click on the **OK** button to accept the settings.
- AutoCAD will now **filter out** objects that are not on layer *Object*.

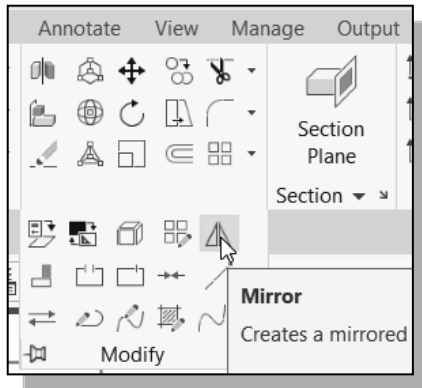

9. Click on the **Mirror** icon in the *Modify* toolbar.
10. Inside the graphics window, hold down the **[SHIFT]** key and **right-click** once to bring up the *Object Snap* shortcut menu.
11. Select the **Midpoint** option in the pop-up window.

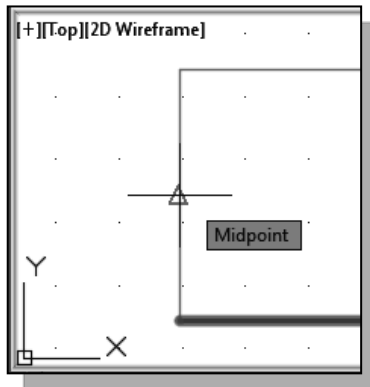
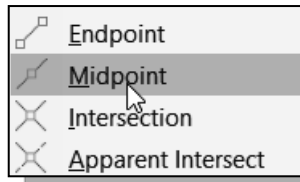

12. Inside the active viewport, click on the left vertical line of the wireframe model. With the *Midpoint* snap option, the midpoint of the line is selected.

13. Move the cursor toward the right vertical line in the active viewport; left-click once when the **Intersection** symbol is displayed as shown.

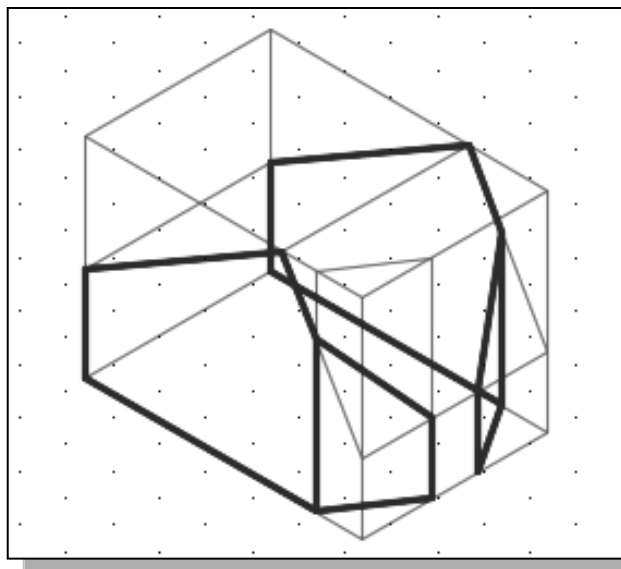
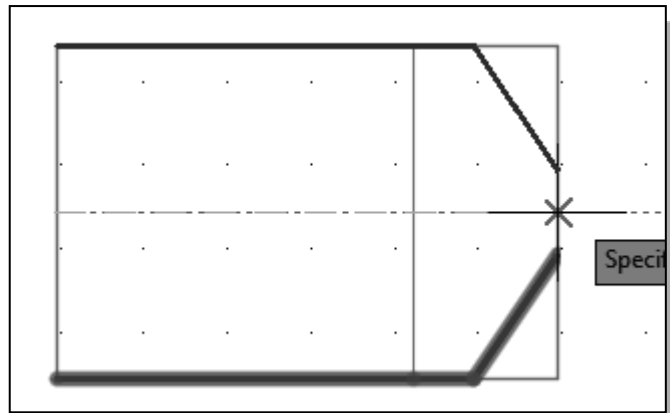

14. In the command prompt area, the message "*Delete Source Objects? [Yes/No] <N>.*" is displayed. Inside the graphics window, right-click once to bring up the option menu and select **No** to keep both sets of objects.

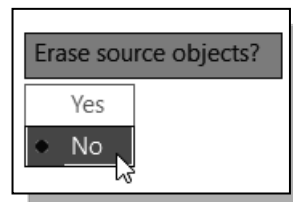

Turn Off the Construction Lines

1. On the *Object Properties* toolbar, choose the **Layer Control** box with the left-mouse-button.

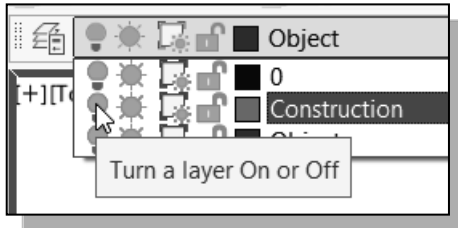

2. Move the cursor over the **light-bulb** icon for layer *Construction*, **left-click once**, and notice the icon color is changed to a gray tone color, representing the layer (layer *Construction*) is turned **OFF**.

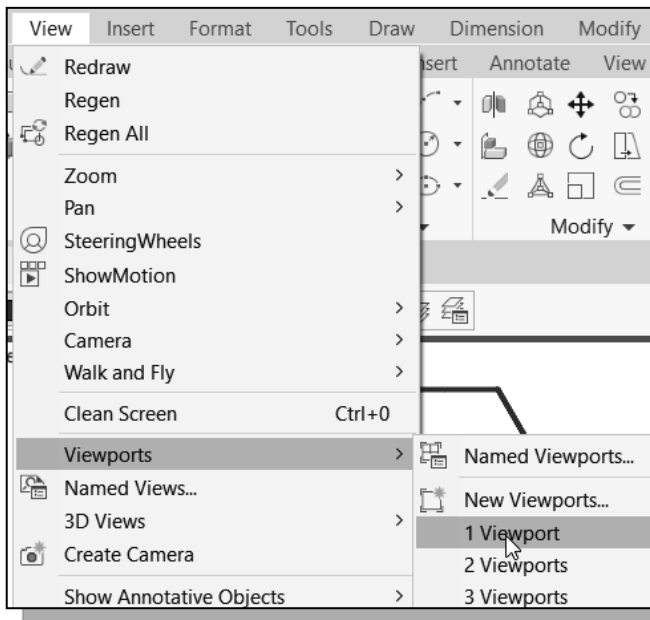

3. In the *Menu Bar*, select:

[View] → [Viewports] → [1 Viewport]

- Viewports can also be used as a way of checking the integrity of the constructed 3D models. Feel free to switch to multiple viewports in the following sections of this tutorial.
4. On your own, create the additional **object lines** connecting the two sets of objects as shown below.

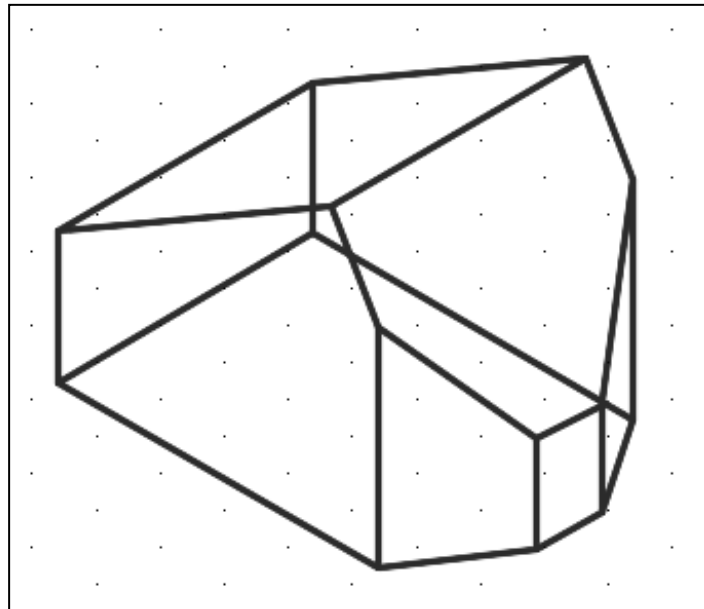

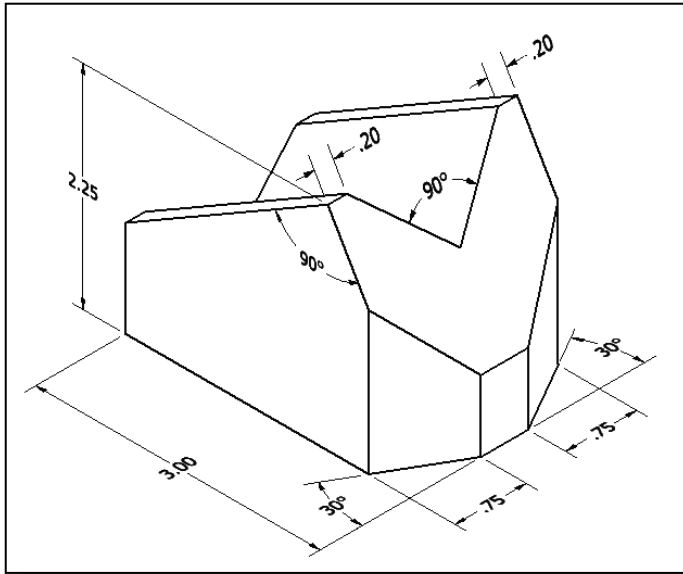

- The V-cut feature of the design is the last feature, and perhaps the most difficult one, to create in the CAD system. Based on your knowledge of modeling with AutoCAD, how would you create this feature? What are the more difficult aspects of creating this feature?

Create a New UCS

Besides using the preset UCS planes, AutoCAD also allows us to change our viewpoint and create new UCS planes. We will create a UCS plane aligning to the inclined plane of the design.

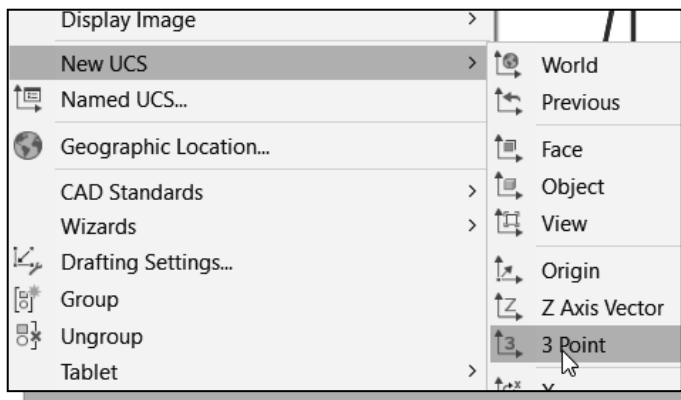

1. In the *Menu Bar*, select:
[Tools] → [New UCS] → [3 Point]
 - Note that other options are also available to aid in the creation of new UCS planes.

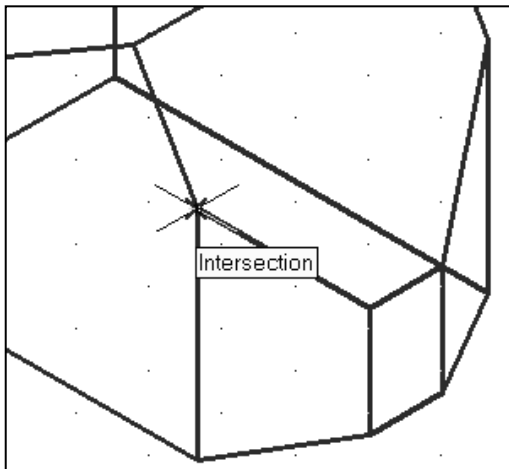

2. In the command prompt area, the message "*Specify New Origin point <0,0,0>:*" is displayed. Pick the lower-left corner of the inclined plane as shown.

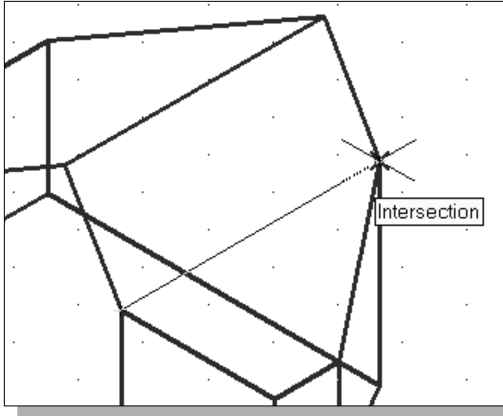

- In the command prompt area, the message “Specify point on positive portion of X-axis:” is displayed. Pick the lower right corner of the inclined plane as shown.

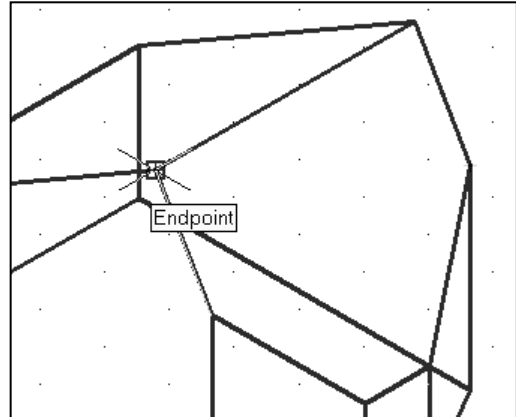

- In the command prompt area, the message “Specify point on positive portion of X-axis:” is displayed. Pick the top left corner of the inclined plane as shown.

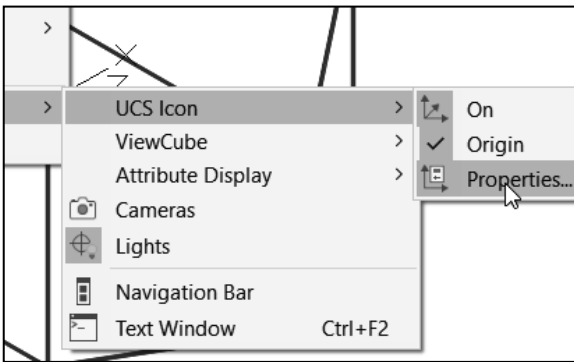

- In the *Menu Bar*, select

[View] → [Display] → [UCS Icon] → [Properties]

- In the *UCS Icon* window, switch the *UCS icon style* to **2D** as shown.

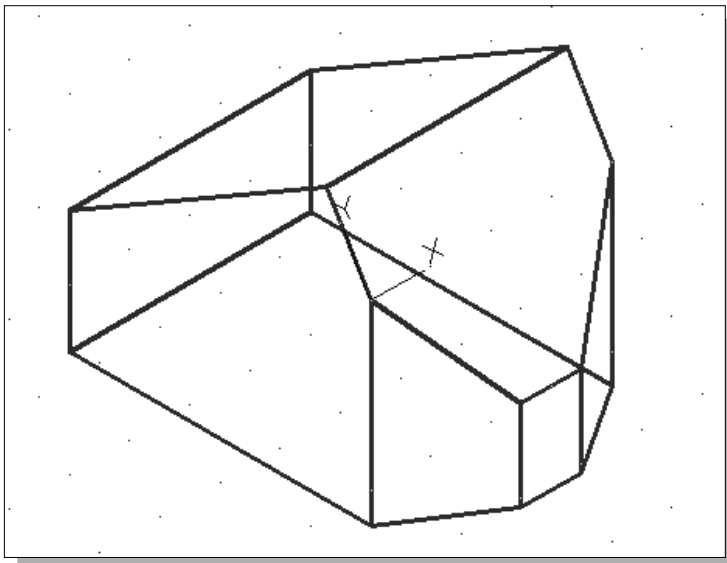
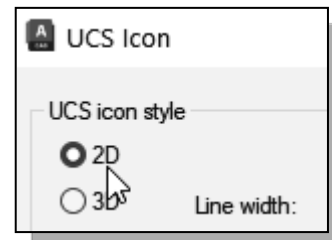

- Click on the **OK** button to accept the settings.

Create a New Named View

Besides using the preset views, AutoCAD also allows us to change our viewpoint and create new views, which can be saved and restored by name for convenient access. We will create a new view aligned to the new UCS plane we just created.

1. In the *Menu Bar*, select
[View] → [3D Views] → [Plan View] → [Current UCS].

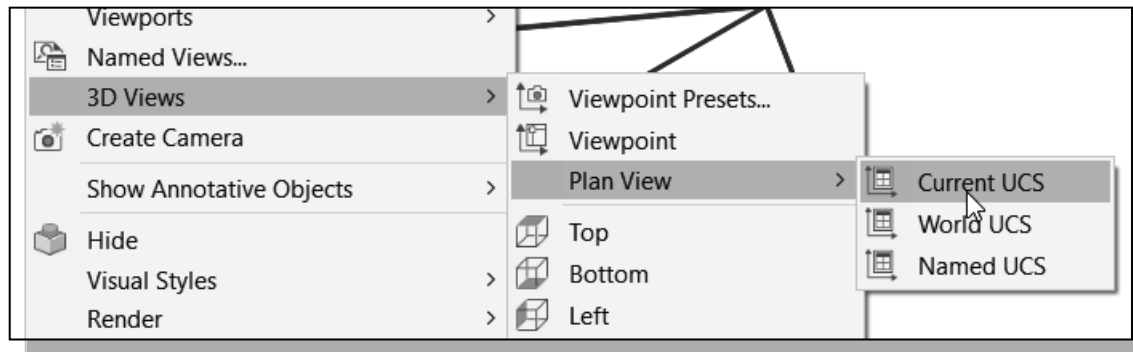

- The graphics window is now adjusted to display the current UCS plane.

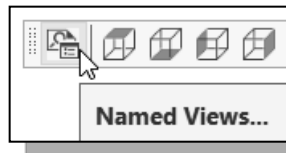
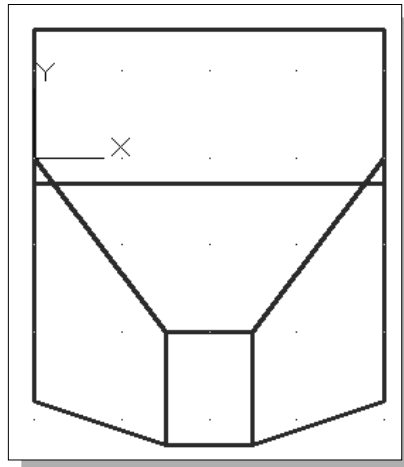

2. Click on the **Named Views** icon in the *View* toolbar.

3. In the *View* dialog box, click on the **New** button to create a new named view.

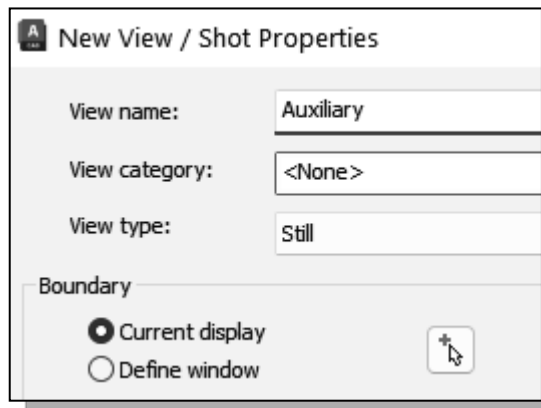
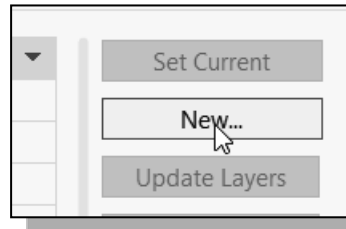

4. In the *New View* dialog box, enter **Auxiliary** as the new *View name* and confirm the **Current display** option. In the *View Properties* list, set the **Save layer Snapshot with view** option to **ON** and the *UCS* option as **Unnamed**.
5. Click on the **OK** button to accept the settings and create the named view.

- In the *View* dialog box, the new named view (**Auxiliary**) is added to the *Named Views* list. Note that we can always switch to this view by using the **Set Current** option.

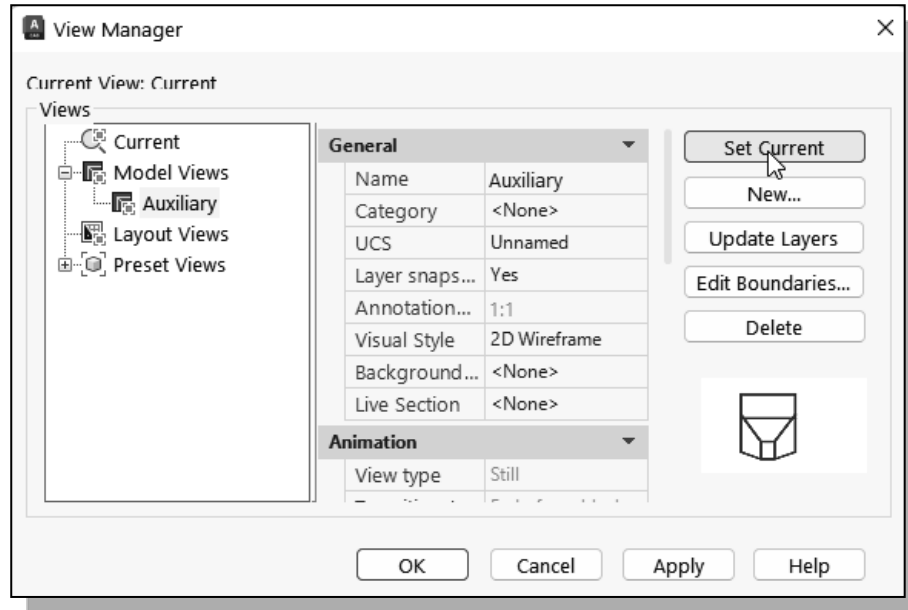

- Click on the **OK** button to accept the settings.

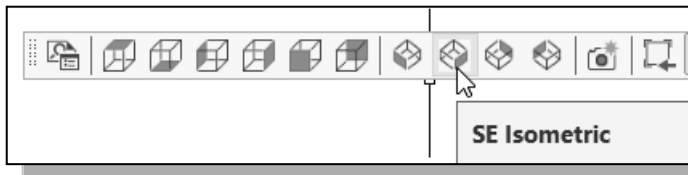

- In the *View* toolbar, select **SE Isometric View**.

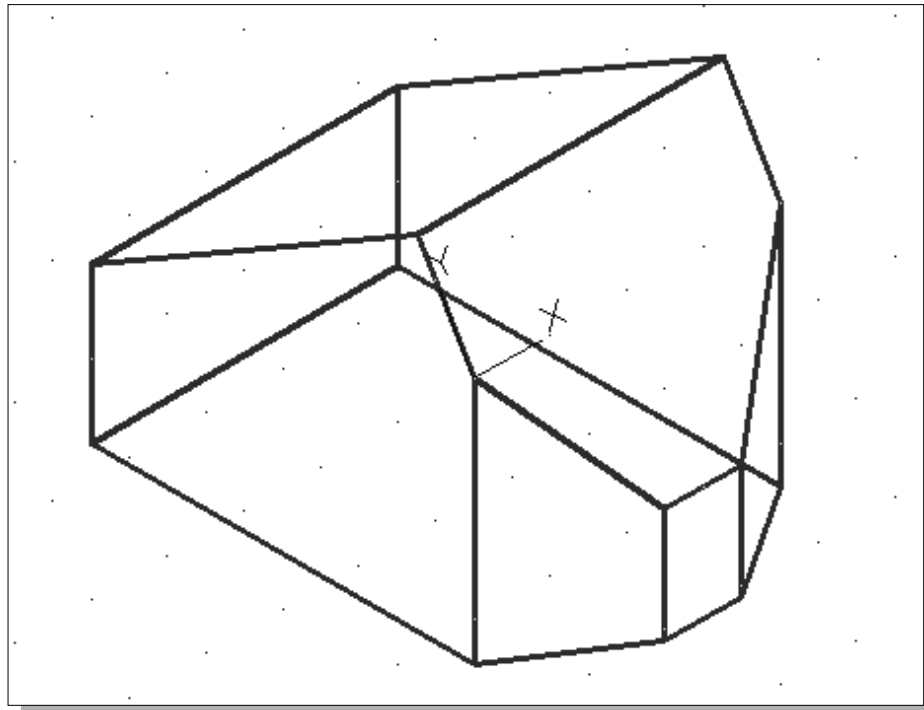

Create the V-Cut Feature on the Inclined Plane

1. On your own, create two lines that are **0.2"** away from the top corners of the model, which are also rotated **45 degrees** relative to the top edge of the model.

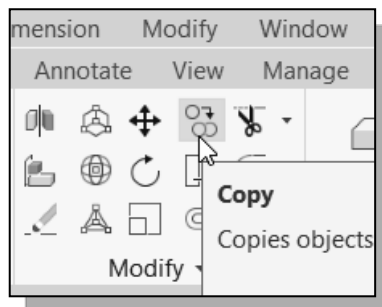
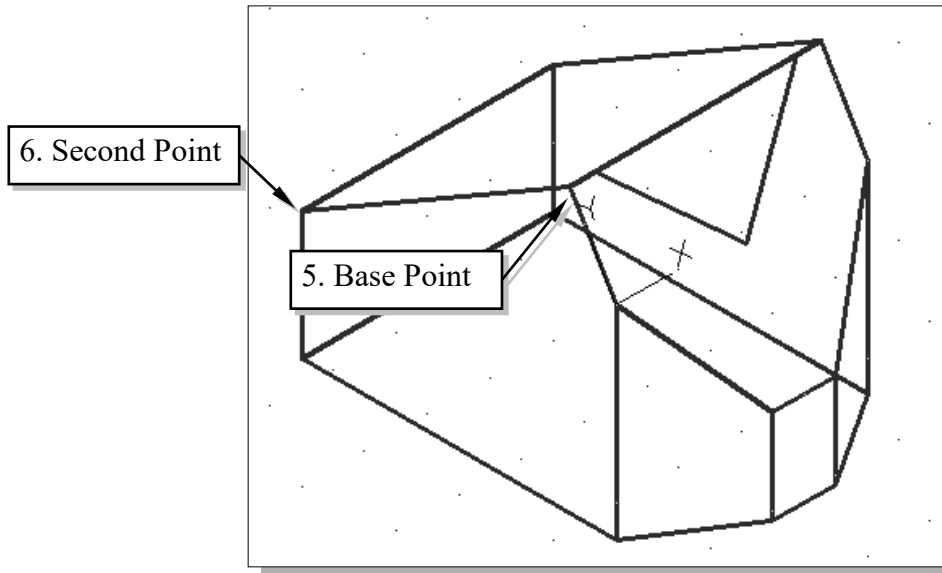

2. Click on the **Copy Object** icon in the *Modify* toolbar.
3. In the command prompt area, the message “*Select objects:*” is displayed. Pick the two inclined lines we just created.
4. Inside the graphics window, **right-click** once to accept the selections.
5. In the command prompt area, the message “*Specify base point or displacement, or [Multiple]:*” is displayed. Pick the **top left corner** as the base point to create the copy.

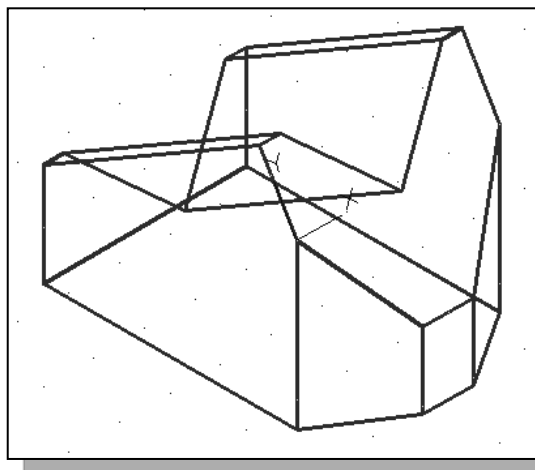

6. In the command prompt area, the message “*Specify second point of displacement or <use first point as displacement>:*” is displayed. Pick the corresponding corner on the **backside** of the model as shown in the above figure.
7. On your own, create addition lines to define the edges of the V-cut and use the **Trim** command to complete the model as shown.



8. Click on the **Front View** icon in the *View* toolbar.

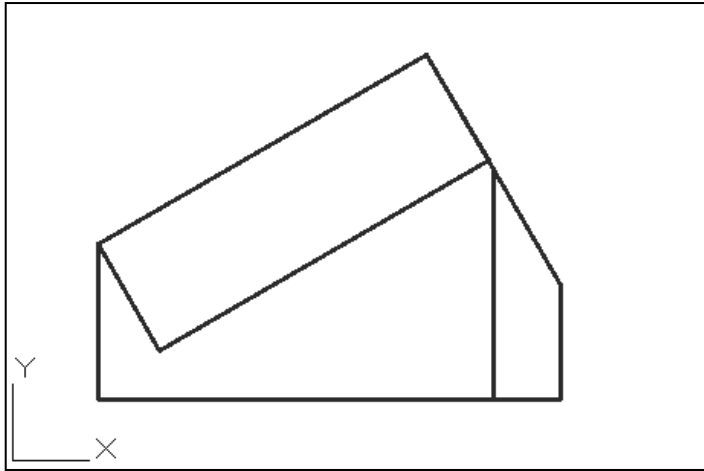

➤ Note that the V-cut we created, using the **Copy** command, does not represent a cut that passes through the entire block.

Extend the Cut and GRIP Editing

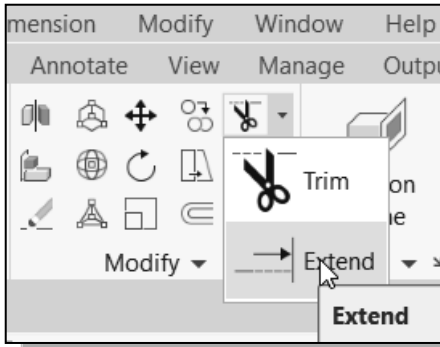

1. Select the **Extend** command icon in the *Modify* toolbar.

2. The message “*Select object to Extend or [Project/ Edge/ Undo]:*” is displayed in the command prompt area. Pick the bottom edge of the V-cut to extend.

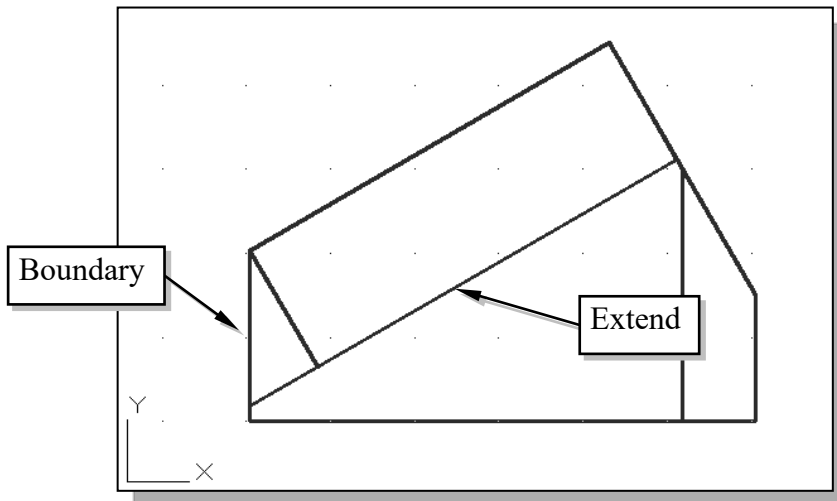

3. Inside the graphics window, **right-click** to activate the option menu and select **Enter** with the left-mouse-button to end the **Extend** command.



4. Click on the **SW Isometric View** icon to reset the display to the preset isometric view.

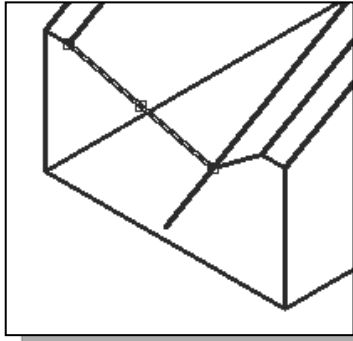

5. *Pre-select* the top edge of the *V-block* as shown.
6. Left-click once on the lower right grip point on the selected line.
 - Selecting the grip points located at the end of the line or arc allows us to **STRETCH** the selected line.

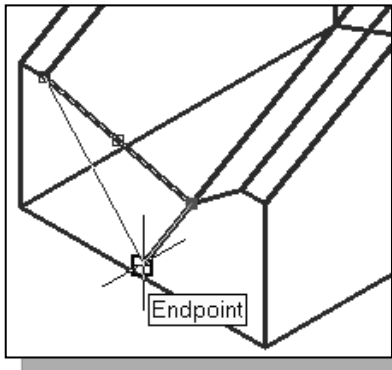

7. Move the cursor toward and select the lower corner of the V-cut as shown.
 - On your own, repeat the above steps and use the grip editing options and complete the wireframe model as shown below.

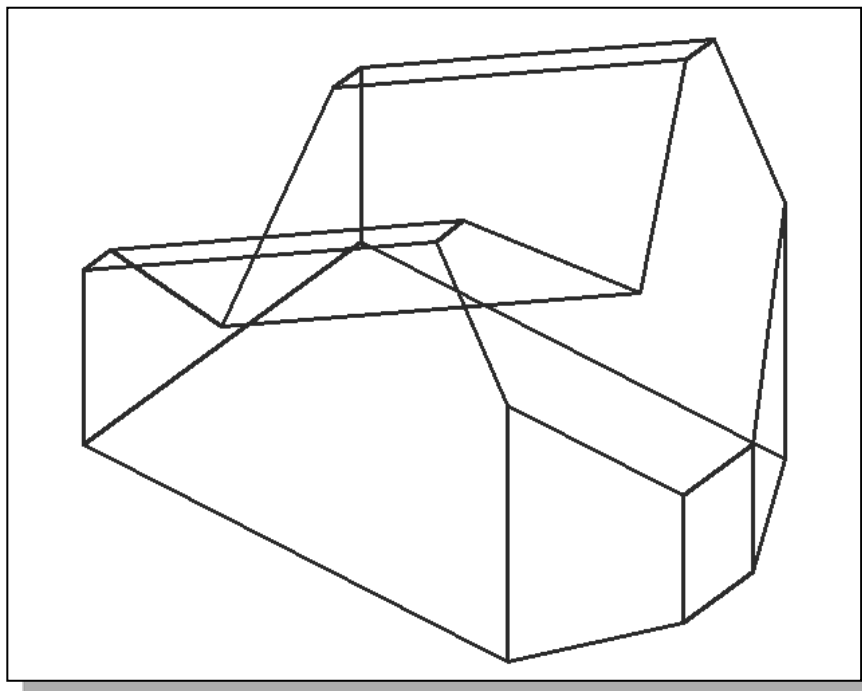

Review Questions:

1. List and describe three different types of 3D computer geometric modeling software available today.
2. What is a *Named View*?
3. What is the difference between **Stretch** and **Extend**?
4. List and describe the methods available in AutoCAD to create a new UCS plane.
5. What is the difference between **Copy** and **Mirror** in AutoCAD?
6. Identify and describe the following commands:

a)

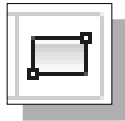

b)



c)

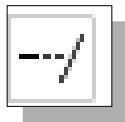

d)

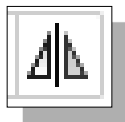

Exercises: (Unless otherwise specified, dimensions are in inches.)

1.

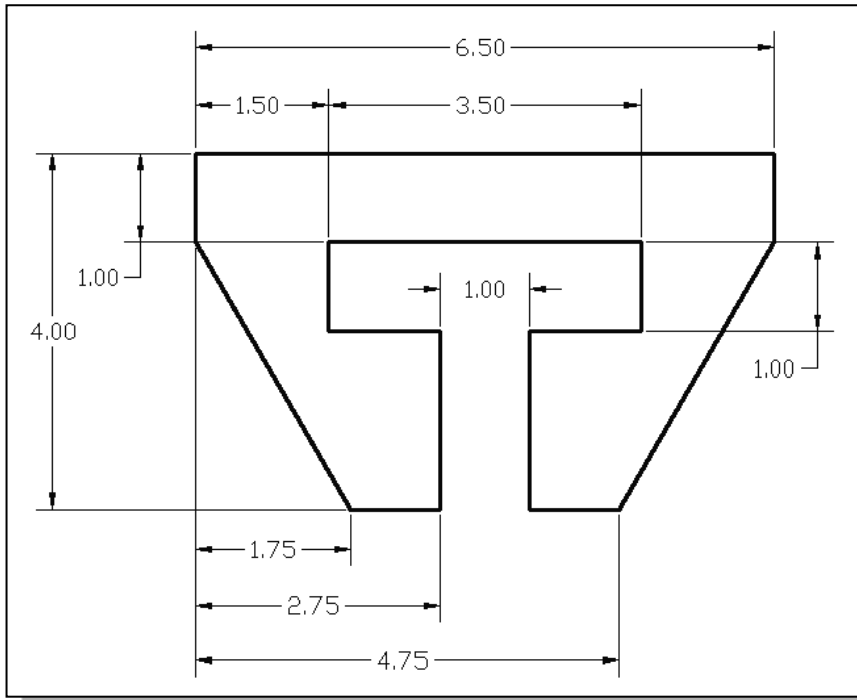

2.

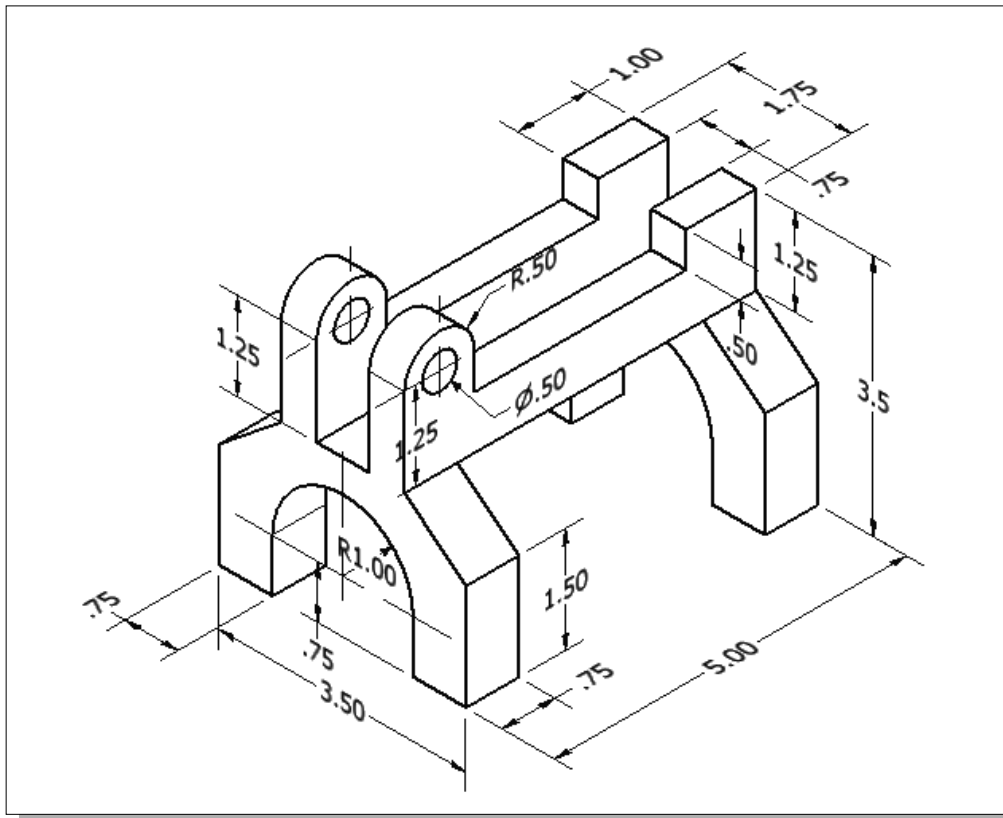

3.

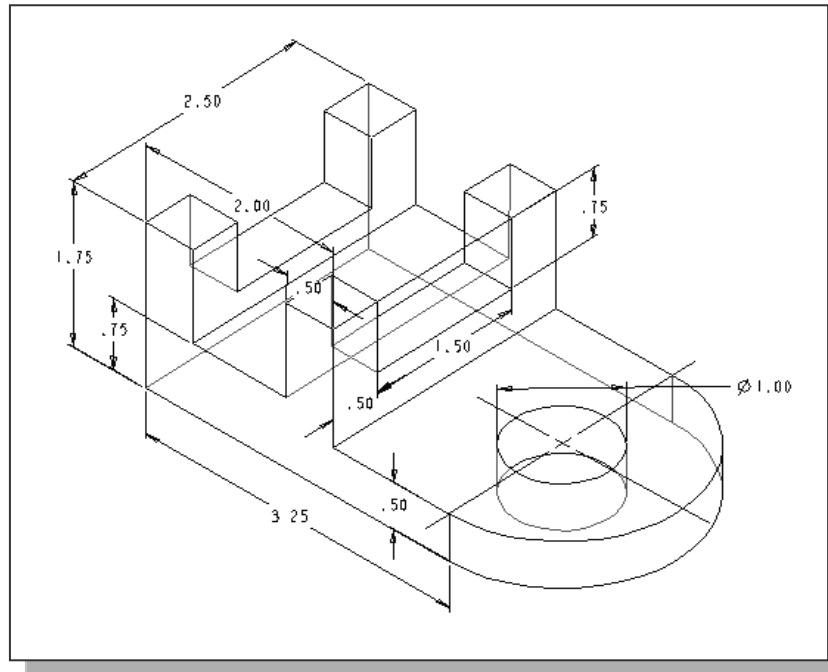

4.

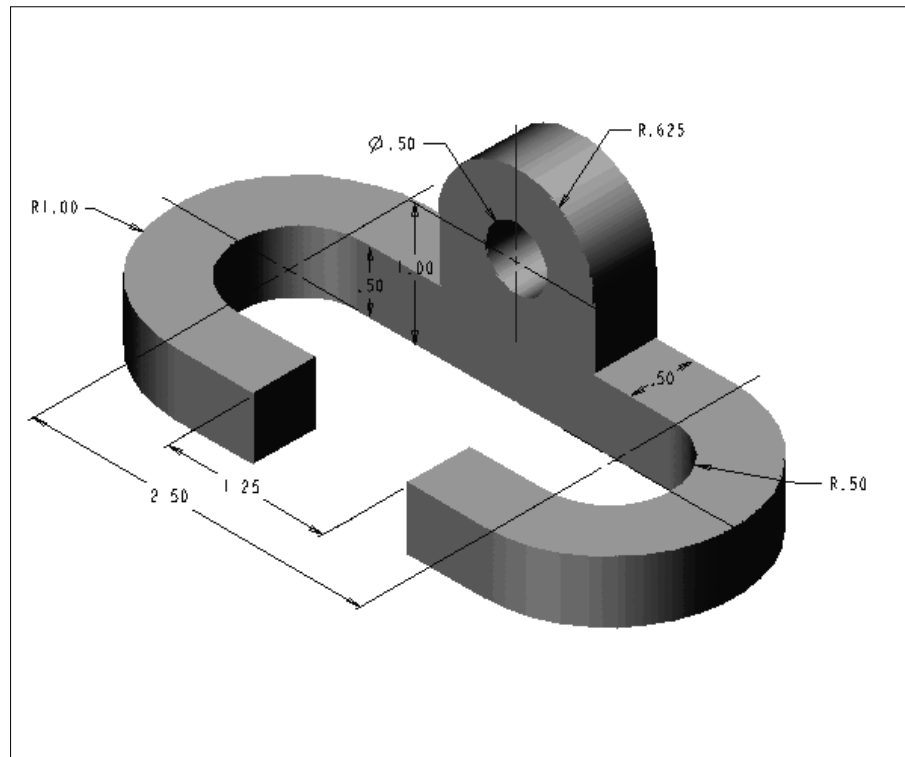

5.

