

Parametric Modeling with SIEMENS® NX®

Spring 2022 Edition

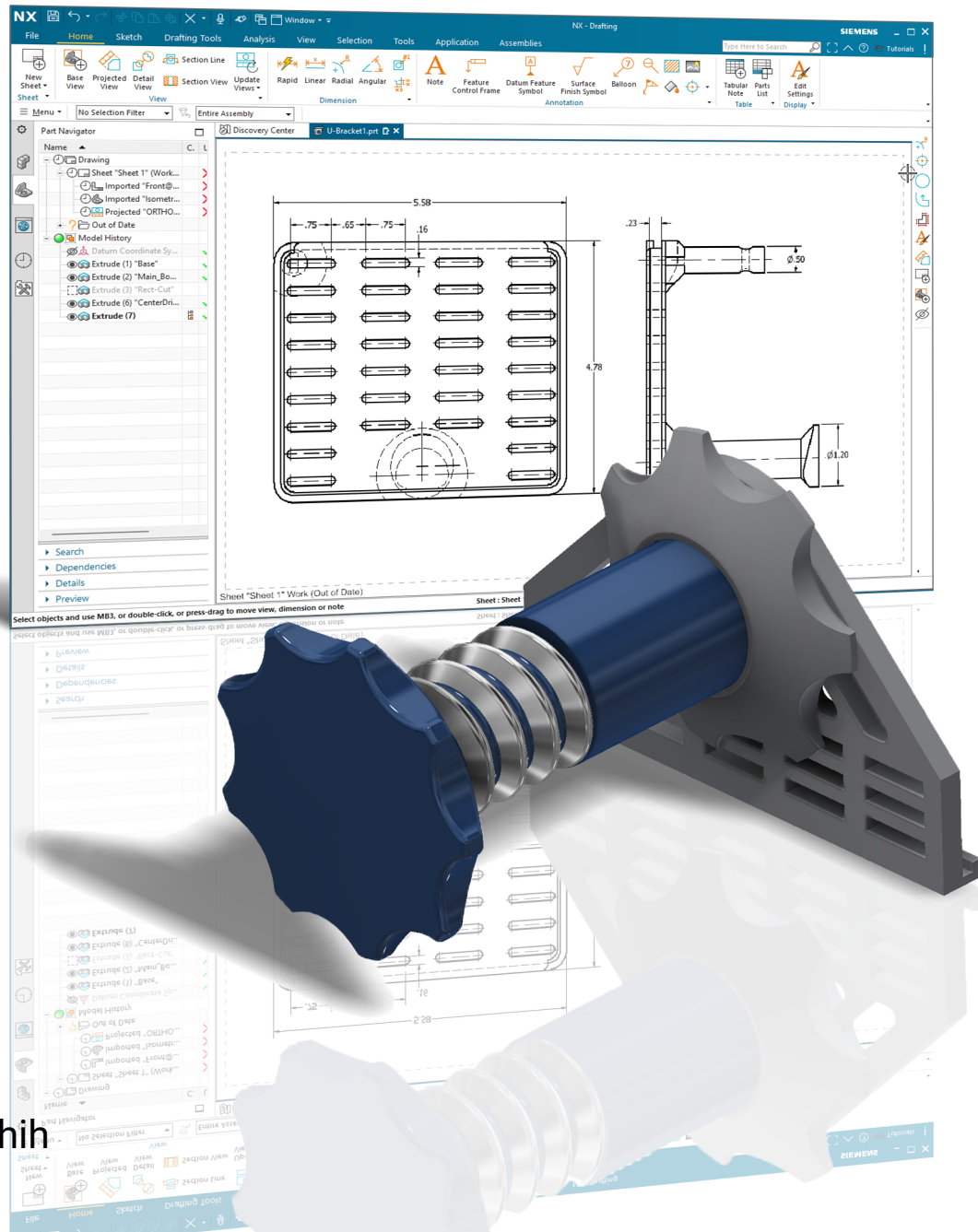

Randy H. Shih

Visit the following websites to learn more about this book:



[amazon.com](https://www.amazon.com)

[Google books](https://books.google.com)

[BARNES & NOBLE](https://www.barnesandnoble.com)

Chapter 2

Parametric Modeling Fundamentals

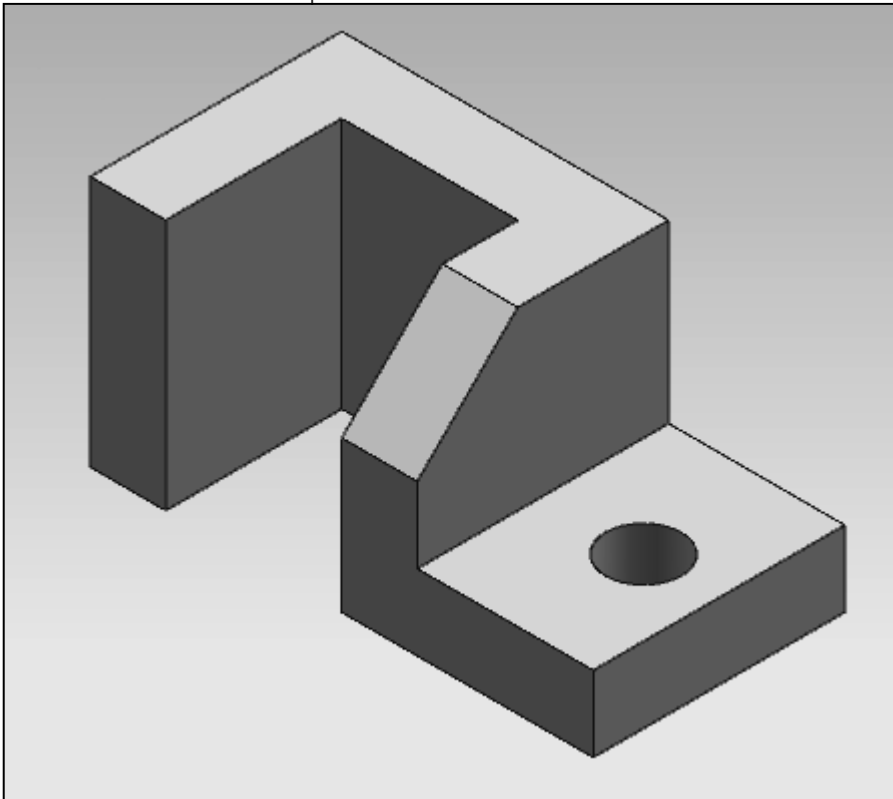

Learning Objectives

- ◆ Create Simple Extruded Solid Models
- ◆ Understand the Basic Parametric Modeling Procedure
- ◆ Create 2D Sketches
- ◆ Understand the "Shape before Size" Approach
- ◆ Use the Dynamic Viewing Commands
- ◆ Create and Edit Parametric Dimensions



Introduction

The **feature-based parametric modeling** technique enables the designer to incorporate the original **design intent** into the construction of the model. The word *parametric* means the geometric definitions of the design, such as dimensions, can be varied at any time in the design process. Parametric modeling is accomplished by identifying and creating the key features of the design with the aid of computer software. The design variables, described in the sketches and described as parametric relations, can then be used to quickly modify/update the design.

In *Siemens NX*, the parametric part modeling process involves the following steps:

1. Set up **Units** and **Part name**.
2. Determine the type of the base feature, the first solid feature, of the design. Note that **Extrude**, **Revolve**, or **Sweep** operations are the most common types of base features.
3. Create a rough two-dimensional sketch of the basic shape of the base feature of the design.
4. Apply/modify constraints and dimensions to the two-dimensional sketch.
5. Transform the parametric two-dimensional sketch into a 3D solid.
6. Add additional parametric features by identifying feature relations and complete the design.
7. Perform analyses/simulations, such as finite element analysis (FEA) or cutter path generation (CNC), on the computer model and refine the design as needed.
8. Document the design by creating the desired 2D/3D drawings.

The approach of creating two-dimensional sketches of the three-dimensional features is an effective way to construct solid models. Many designs are in fact the same shape in one direction. Computer input and output devices we use today are largely two-dimensional in nature, which makes this modeling technique quite practical. This method also conforms to the design process that helps the designer with conceptual design along with the capability to capture the *design intent*. Most engineers and designers can relate to the experience of making rough sketches on restaurant napkins to convey conceptual design ideas. *Siemens NX* provides many powerful modeling and design-tools, and there are many different approaches to accomplishing modeling tasks. The basic principle of **feature-based modeling** is to build models by adding simple features one at a time. In this chapter, the general parametric part modeling procedure is illustrated; a very simple solid model with extruded features is used to introduce the *Siemens NX* user interface.

The Adjuster Design

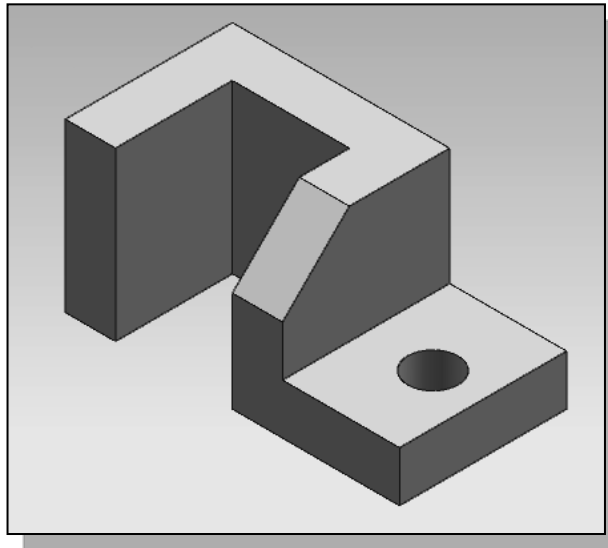

Step 1: Starting Siemens NX and Units Setup

1. Select the **Siemens NX** option on the *Start* menu or select the **Siemens NX** icon on the desktop to start *Siemens NX*. The *Siemens NX* main window will appear on the screen.

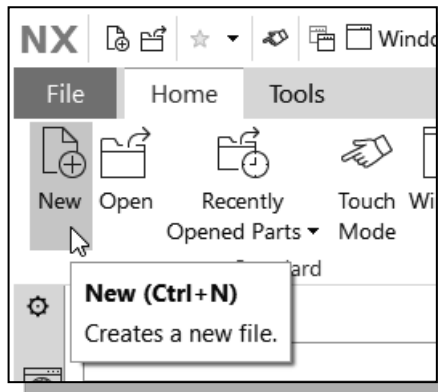
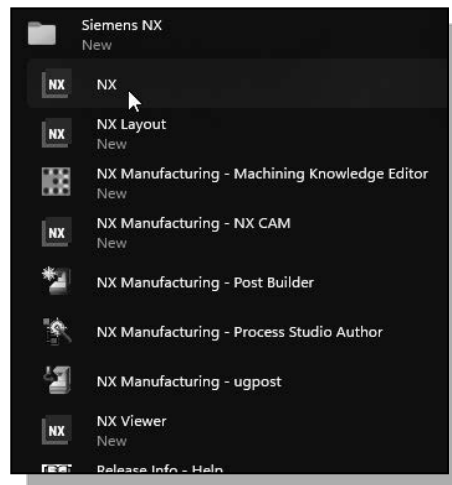
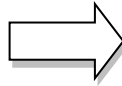

2. Select the **New** icon with a single click of the left-mouse-button (MB1) in the *Standard toolbar area*.

➤ The File New dialog box will appear on the screen with three option tabs: **Model**, **Drawing** and **Simulation**. Note that the default is set to Model and we can create a new model using any of the pre-defined templates.

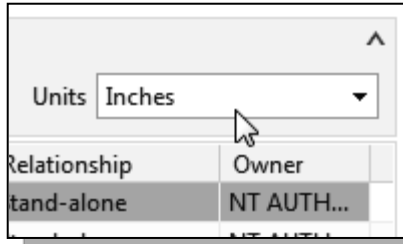

3. Select the **Inches** units as shown in the window. When starting a new CAD file, the first thing we should do is to choose the units we would like to use.

4. Select **Blank** in the *Template list*. Note that the *Blank template* contains no pre-defined settings.

Assembly	Assemblies	Inches	Stand-alone	NT AUTH...
Shape Studio	Shape Studio	Inches	Stand-alone	NT AUTH...
Sheet Metal	Sheet Metal	Inches	Stand-alone	NT AUTH...
Blank	Gateway	Inches	Stand-alone	none

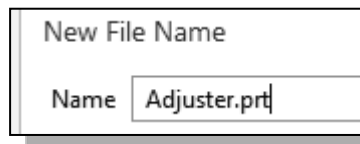

5. In the *New File Name* section, enter **Adjuster.prt** as the *File Name*.

6. Click **OK** to accept the settings and proceed with the new file command.

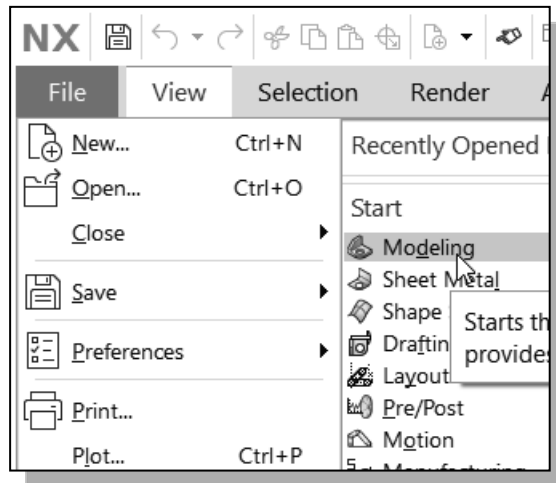

7. Select the **File** tab with a single click of the left-mouse-button (MB1) in the *Ribbon* bar area.
8. Hit [**Ctrl+M**] or pick **Modeling** in the *Applications* list as shown in the figure.

- The above procedure shows the switching of the three Siemens NX **work areas**; we have gone from the "**Gateway**" state to the "**Applications,**" and "**Task environments**" state. In the later chapters, the procedure to use the pre-defined template is also illustrated.
- Note that the Siemens NX Modeling application allows us to perform both the tasks of **parametric modeling** and **Free-form Synchronous modeling**.
- **Free-Form Synchronous Modeling**
With NX, more complex-shape modeling tasks can also be done, such as the creation of complex surfaces and solid models. For example, creating *swept features* along 3D curves; *lofted features* using conic methods; and *meshes* of points and curves.

Siemens NX Application Screen Layout

- The *Siemens NX* modeling screen layout is quite similar to the *Siemens NX Gateway Application* screen layout (refer to the figure in page 1-12 for more details). The new items on the screen include the *Sketch* toolbar, *Form Feature* toolbar, the *Feature Operation* toolbar, and the *Curve* toolbar.

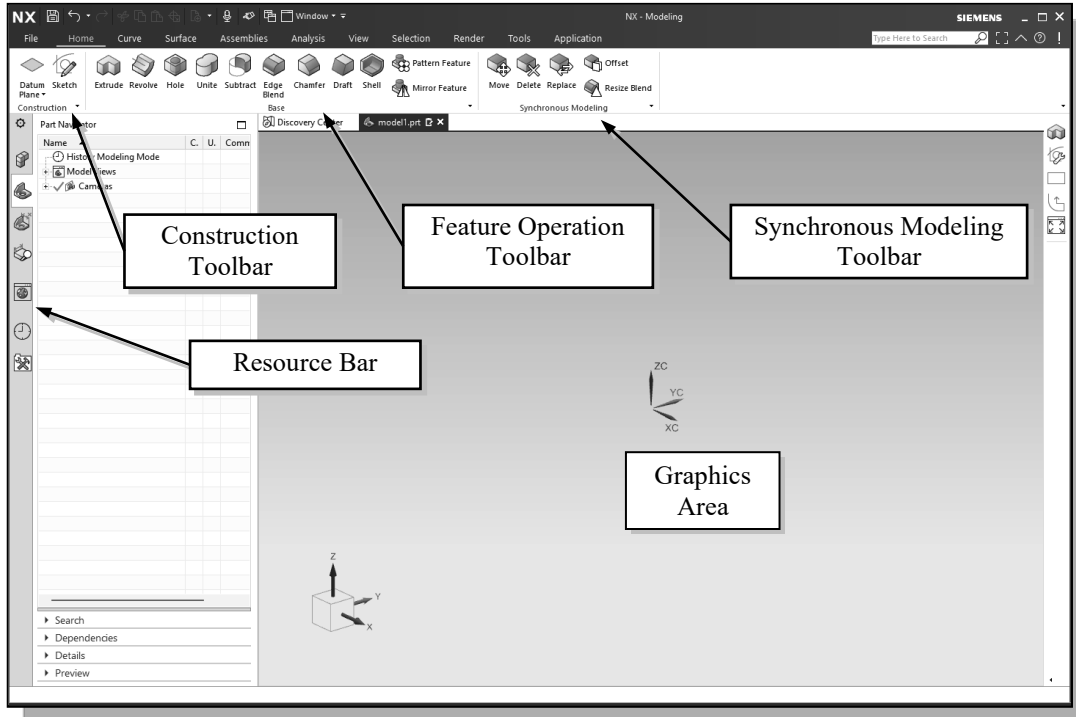

Construction Toolbar

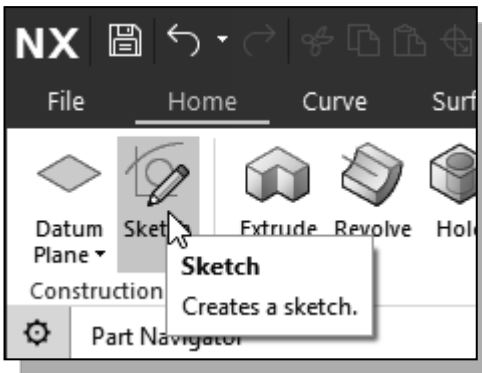

This toolbar contains tools that allow us to quickly access **Datum features** and switch to **Sketch Options**.

Features Toolbar

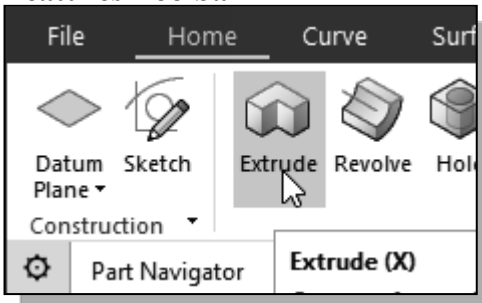

This toolbar contains tools that allow us to quickly create **3D features**.

Step 2: Define/Set up the First Solid Feature

- For the *Adjuster* design, we will create an extruded solid as the first feature.

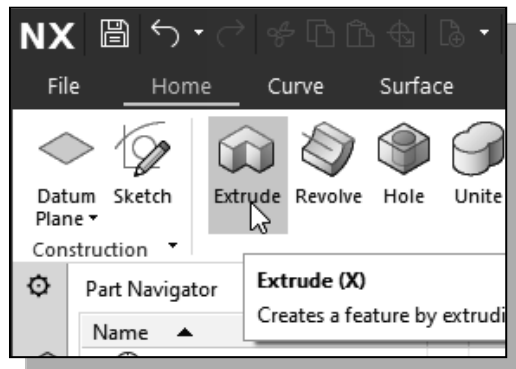

- In the **Feature Toolbar** (toolbar next to the *Sketch* toolbar in the *Ribbon Bar*), select the **Extrude** icon as shown.

- The **Extrude Feature Options Dialogue box**, which contains applicable construction options, is displayed as shown in the below figure.

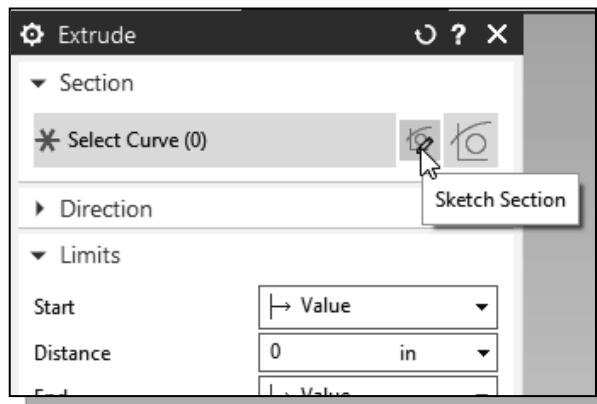

- On your own, move the cursor over the icons and read the brief descriptions of the different options available. Note that the default extrude option is set to **Select Curve**.
- Click the **Sketch Section** button to begin creating a new *2D sketch*.

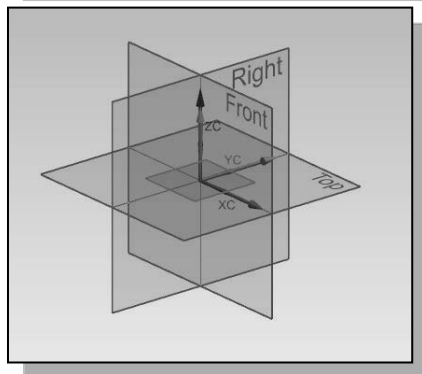

- Note the default sketch plane is aligned to **the XC-YC plane** of the displayed *Work Coordinate System*.

- Click **OK** to accept the default setting of the *Sketch Plane*.

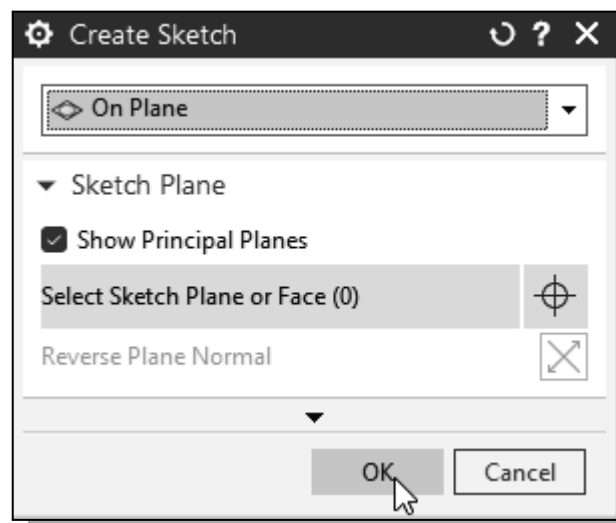

Work Plane – It is an XY CRT, but an XYZ World

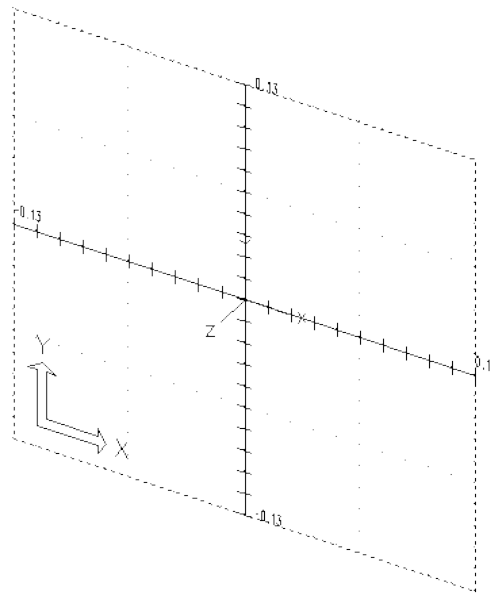

Design modeling software is becoming more powerful and user friendly, yet the system still does only what the user tells it to do. When using a geometric modeler, we therefore need to have a good understanding of what its inherent limitations are. We should also have a good understanding of what we want to do and what to expect, as the results are based on what is available.

In most 3D geometric modelers, 3D objects are located and defined in what is usually called the **absolute space** or **global space**. Although a number of different coordinate systems can be used to create and manipulate objects in a 3D modeling system, the objects are typically defined and stored using the absolute space. The absolute space is usually a **3D Cartesian coordinate system** that the user cannot change or manipulate.

In most engineering designs, models can be very complex, and it would be tedious and confusing if only one coordinate system, the absolute coordinate system, was available. Practical 3D modeling systems allow the user to define **Work Coordinate Systems (WCS)**, also known as **Local Coordinate Systems (LCS)** or **User Coordinate Systems (UCS)** relative to the absolute coordinate system. Once a local coordinate system is defined, we can then create geometry in terms of this more convenient system.

The basic concepts of coordinate systems remain the same for most CAD systems, but the actual usage of a particular type of coordinate system may vary greatly from one CAD system to another. Siemens NX has two primary coordinate systems: the **Absolute Coordinate System (ACS)** and the **Work Coordinate System (WCS)**. The ACS is fixed in space, where the WCS is a mobile system to facilitate geometry construction in different orientations. The WCS can be located and oriented anywhere in model space.

Although 3D objects are generally created and stored in 3D space coordinates, most of the 3D geometry entities can be referenced using 2D Cartesian coordinate systems. Typical input devices such as a mouse or digitizers are two-dimensional by nature; the movement of the input device is interpreted by the system in a planar sense. The same limitation is true of common output devices, such as CRT displays and plotters. The modeling software performs a series of three-dimensional to two-dimensional transformations to correctly project 3D objects onto a 2D picture plane.

The *Siemens NX sketch plane* is a special construction tool that enables the planar nature of 2D input devices to be directly mapped into the 3D coordinate systems. The *sketch plane* is part of the Siemens NX work coordinate system that can be aligned to the absolute coordinate system, an existing face of a part, or a reference plane. By default, the *sketch plane* is aligned to the XY plane of the default WCS; note that the default WCS is aligned to the absolute coordinate system (ACS).

Think of a sketch plane as the surface on which we can sketch the 2D sections of the parts. It is similar to a piece of paper, a white board, or a chalkboard that can be attached to any planar surface. The first profile we create is usually drawn on one of the work planes of the work coordinate system (WCS). Subsequent profiles can then be drawn on sketch planes that are defined on **planar faces of a part**, **work planes aligned to part geometry**, or **work planes attached to a coordinate system** (such as the XY, XZ, and YZ planes of WCS).

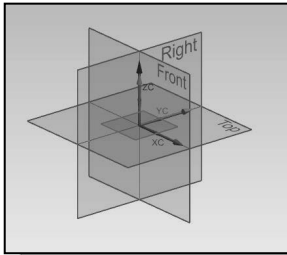

- ❖ The default sketch plane is aligned to the XY plane of the Work Coordinate System.

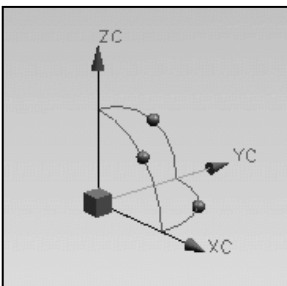

- ❖ The *work coordinate system* (WCS) is a mobile system to assist geometric constructions in different orientations. The WCS can be located and oriented anywhere in model space.

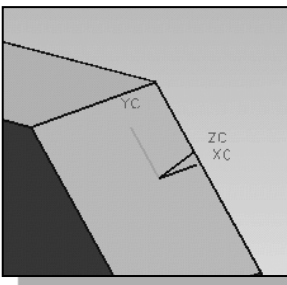

- ❖ Note that most solid modeling operations do not require manipulation of the WCS. Solid Features are generally added relative to existing geometry of the solid model.

Creating Rough Sketches

Quite often during the early design stage, the shape of a design may not have any precise dimensions. Most conventional CAD systems require the user to input the precise lengths and locations of all geometric entities defining the design, which are not available during the early design stage. With *parametric modeling*, we can use the computer to elaborate and formulate the design idea further during the initial design stage. With *Siemens NX*, we can use the computer as an electronic sketchpad to help us concentrate on the formulation of forms and shapes for the design. This approach is the main advantage of *parametric modeling* over conventional solid-modeling techniques.

As the name implies, a **rough sketch** is not precise at all. When sketching, we simply sketch the geometry so that it closely resembles the desired shape. Precise scale or lengths are not needed. *Siemens NX* provides us with many tools to assist us in finalizing sketches. For example, geometric entities such as horizontal and vertical lines are set automatically. However, if the rough sketches are poor, it will require much more work to generate the desired parametric sketches. Here are some general guidelines for creating sketches in *Siemens NX*:

- **Create a sketch that is proportional to the desired shape.** Concentrate on the shapes and forms of the design.
 - **Keep the sketches simple.** Leave out small geometry features such as fillets, rounds and chamfers. They can easily be placed using the **Fillet** and **Chamfer** commands after the parametric sketches have been established.
 - **Exaggerate the geometric features of the desired shape.** For example, if the desired angle is 85 degrees, start by creating an angle that is 50 or 60 degrees (and make adjustment later). Otherwise, *Siemens NX* might assume the intended angle to be a 90-degree angle.
 - **Draw the geometry so that it does not overlap.** To create a 3D feature from a 2D sketch, the 2D geometry used should define a clear boundary. *Self-intersecting* geometry shapes are not allowed, as it cannot be converted into a solid feature.
 - **The sketched geometric entities should form a closed region.** To create a solid feature, such as an extruded solid, a closed region is required so that the extruded solid forms a 3D volume.
- **Note:** The concepts and principles involved in *parametric modeling* are very different, and sometimes they are totally opposite, to those of conventional computer aided drafting. In order to understand and fully utilize *Siemens NX*'s functionality, it will be helpful to take a *Zen* approach to learning the topics presented in this text: **Temporarily forget your knowledge and experiences of using conventional Computer Aided Drafting systems.**

Step 3: Creating a Rough 2D Sketch

- The *Sketch Curve* toolbar provides tools for creating and editing of the basic 2D geometry, construction tools such as lines, circles and editing tools such as trim, extend.

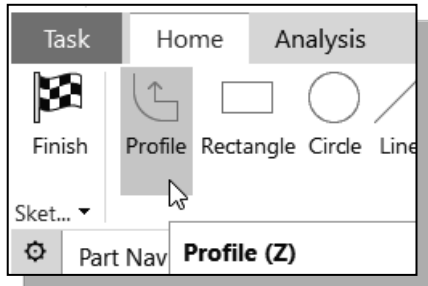

1. Activate the **Profile** tool in the *Sketch Curve toolbar* as shown.

- The **Profile** tool allows us to create lines and/or arcs that are joined together.

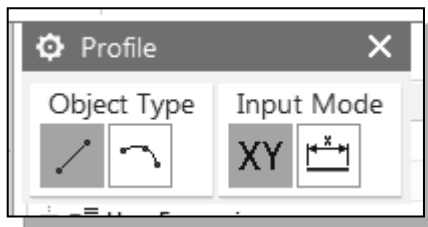

- Notice, by default, the **Line** option is activated. The **line** option allows us to create line segments that are joined together.

2. As you move the cursor, you will see a digital readout next to the cursor. The readout gives you the cursor location relative to the Work Coordinate System. Pick a location that is toward the right side of the WCS as the first point of a line.
3. Move the cursor around and you will notice the readout, next to the cursor, providing the length and angle of the line.

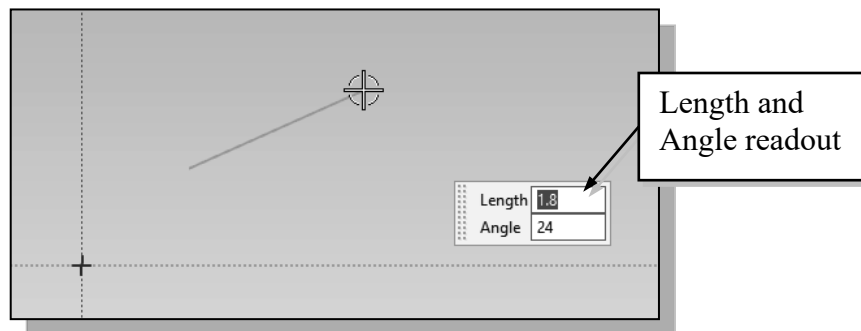



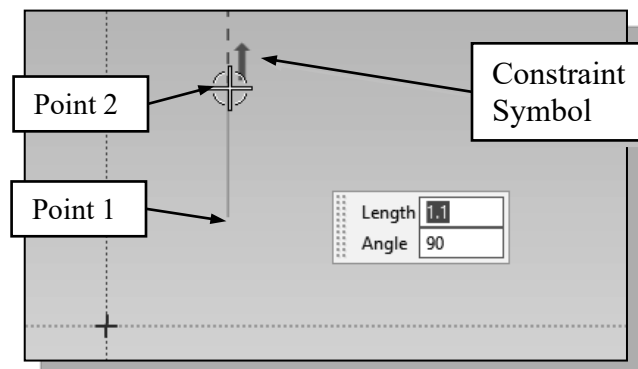









4. Move the graphics cursor directly above the previous point and create a vertical line as shown below (**Point 2**). Notice the geometric constraint symbol displayed.



Geometric Constraint Symbols

Siemens NX displays different visual clues, or symbols, to show you alignments, perpendicularities, tangencies, etc. These constraints are used to capture the *design intent* by creating constraints where they are recognized. *Siemens NX* displays the governing geometric rules as models are built. To prevent constraints from forming, hold down the [Alt] key while creating an individual sketch curve. For example, while sketching line segments with the Line command, endpoints are joined with a *coincident constraint*, but when the [Alt] key is pressed and held, the inferred constraint will not be created.

	Vertical	indicates a line is vertical
	Horizontal	indicates a line is horizontal
	Dashed line	indicates the alignment is to the center point or endpoint of an entity
	Parallel	indicates a line is parallel to other entities
	Perpendicular	indicates a line is perpendicular to other entities
	Coincident	indicates the cursor is at the endpoint of an entity
	Concentric	indicates the cursor is at the center of an entity
	Tangent	indicates the cursor is at tangency points to curves
	Midpoint	indicates the cursor is at the midpoint of an entity
	Point on Curve	indicates the cursor is on curves
	Equal Length	indicates the length of a line is equal to another line
	Equal Radius	indicates the radius of an arc is equal to another arc

- Complete the sketch as shown below, creating a closed region ending at the starting point (Point 1.) Do not be overly concerned with the actual size of the sketch. Note that all line segments are sketched horizontally or vertically.

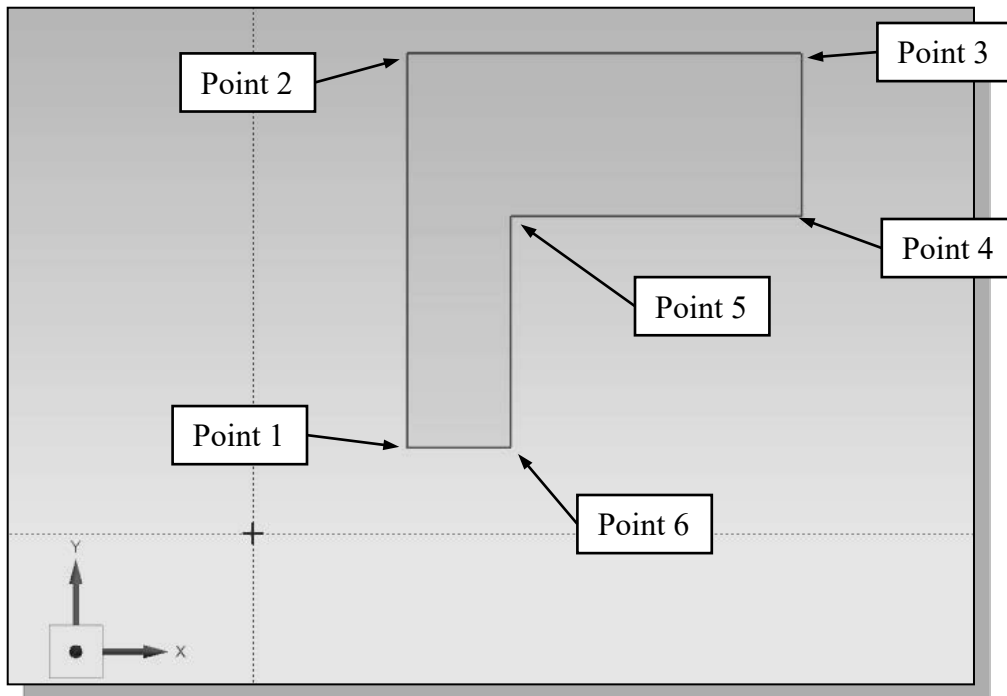

- Inside the graphics window, click twice with the **middle-mouse-button (MB2)**, or press the **[Esc]** key twice, to end the Sketch Line command.

Step 4: Apply/Modify Constraints and Dimensions

- As the sketch is made, *Siemens NX* automatically applies some of the geometric constraints (such as horizontal, parallel, and perpendicular) to the sketched geometry. We can continue to modify the geometry, apply additional constraints, and/or define the size of the existing geometry. In this example, we will illustrate adding dimensions to describe the sketched entities.

- Inside the graphics window, select the **Top horizontal line** by left-clicking once on the line. Note a length dimension appears on the screen.

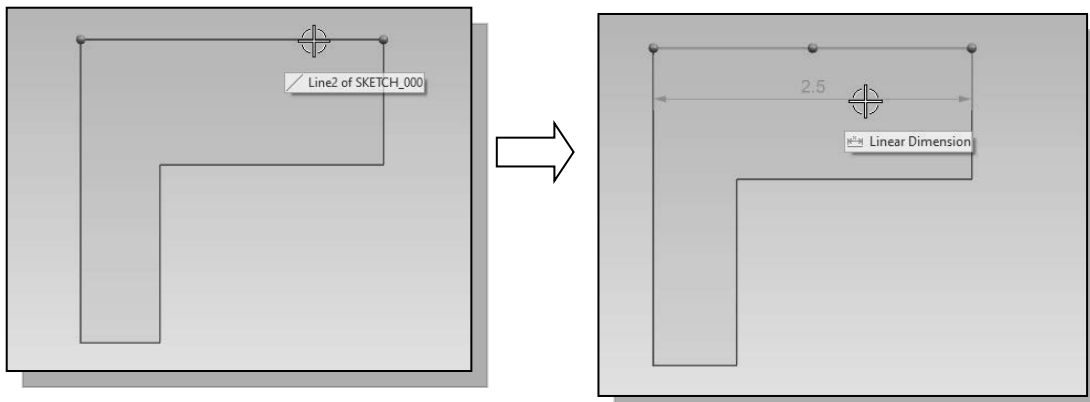

- Click on the **Dimension** to accept the selection and enter the *Edit Dimension* mode.

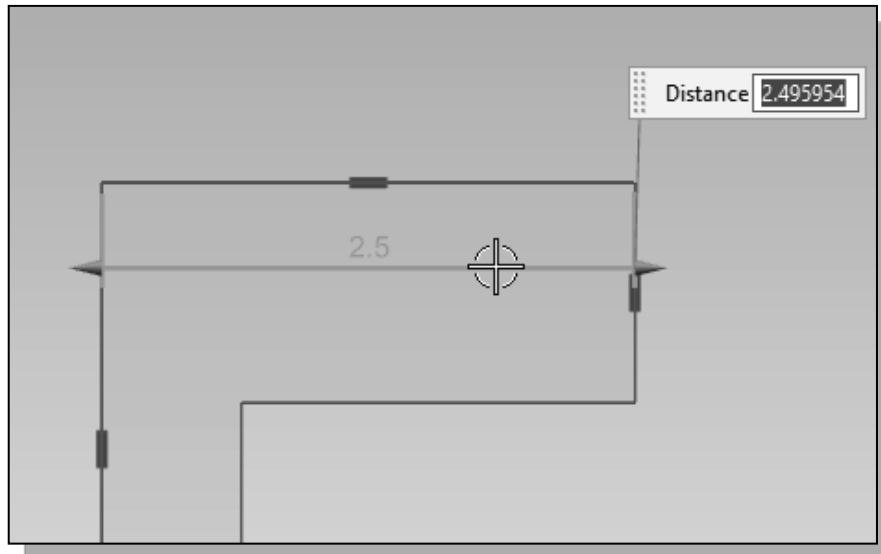

- Enter **2.5** as the desired length of the line. (Press the **Enter** key once after you entered the new value.)

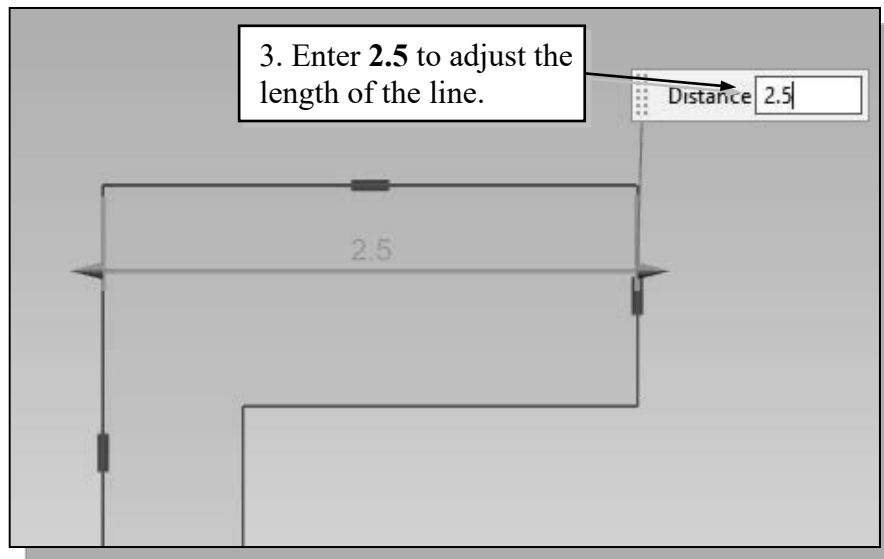

- Since this is the first dimension we are editing, the sketched geometry could become distorted as it is adjusted. Click **Yes** to scale the entire sketch and maintain the proportion of the original sketch.

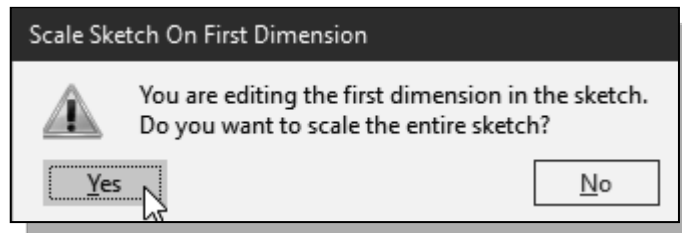

- *Siemens NX* will now update the profile with the new dimension value. Note that in parametric modeling, dimensions are used as **control variables**.
5. Inside the graphics window, click once with the **Middle Mouse button** to accept the adjustment and exit the *Edit Dimension* mode

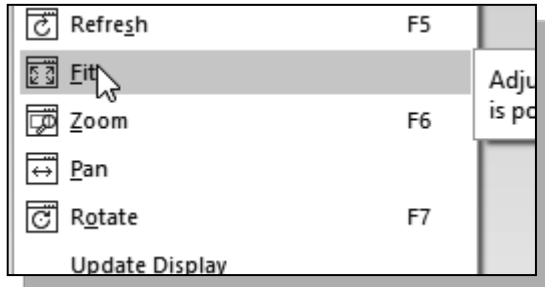

6. Right-mouse-click once to bring up the option menu and select the **Fit** option, or use hotkey [Ctrl+F], to resize the display window.

❖ Note that we can select multiple objects and create associated **Dimension**.

7. Select the top-horizontal line as shown below.

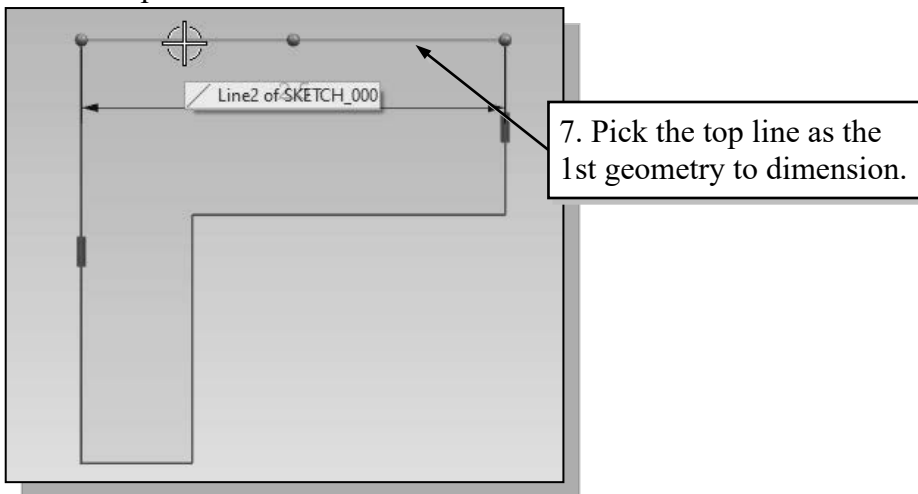

8. Select the bottom-horizontal line as shown below.

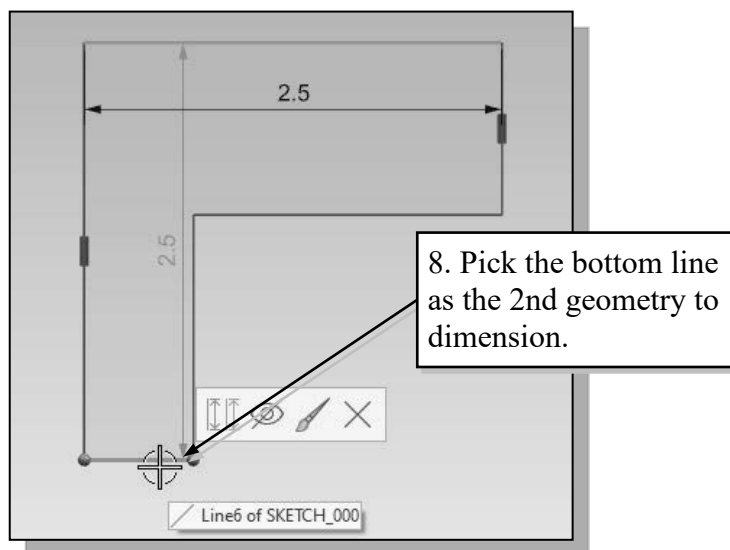

9. Click on the **Dimension** to accept the selection and enter the *Edit Dimension* mode.

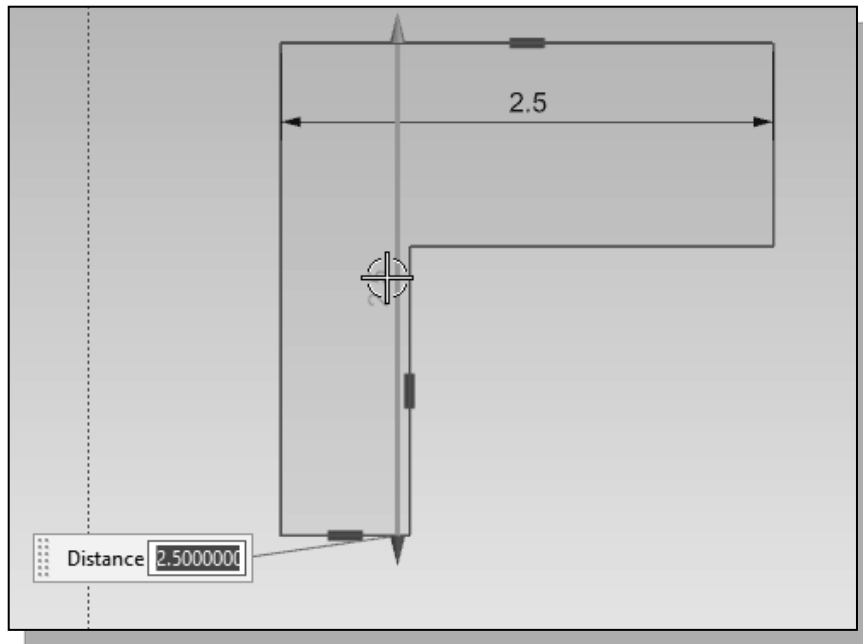

10. On your own, adjust the dimension to **2.5** as shown.

- ❖ When two parallel lines are selected, the Rapid Dimension command will create a dimension measuring the distance between them.
- ❖ **Quick Zoom function by Turning the mouse wheel**



Turning the **mouse wheel** can adjust the scale of the display. Turning forward will reduce the scale of the display, using the cursor location as the center reference, making the entities display smaller on the screen. Turning backward will magnify the scale of the display.

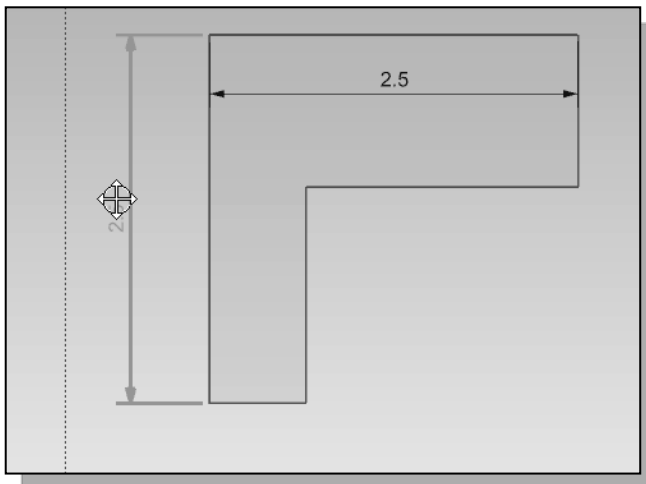

11. To reposition any of the dimensions, simply **press and drag** with the **left-mouse-button (MB1)** on the dimension as shown.

12. Select the bottom-horizontal line as shown below.

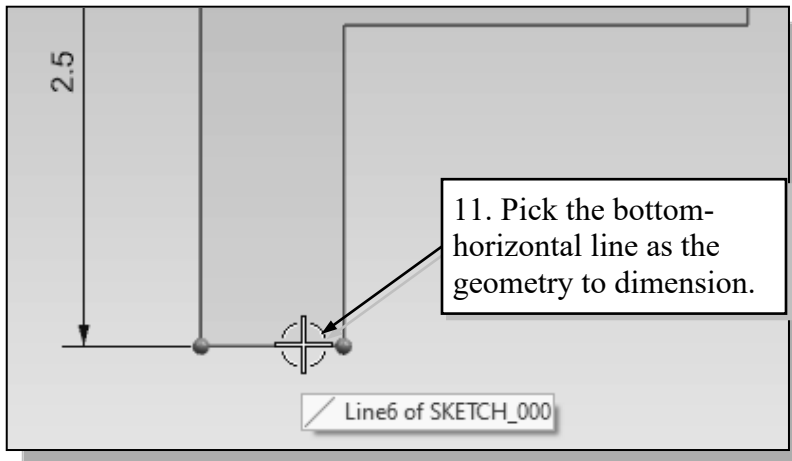

13. Pick the displayed dimension.

14. Enter **0.75** as the desired length of the line.

15. On your own, repeat the above steps, create and modify the additional dimensions so that the sketch appears as shown in the below figure.

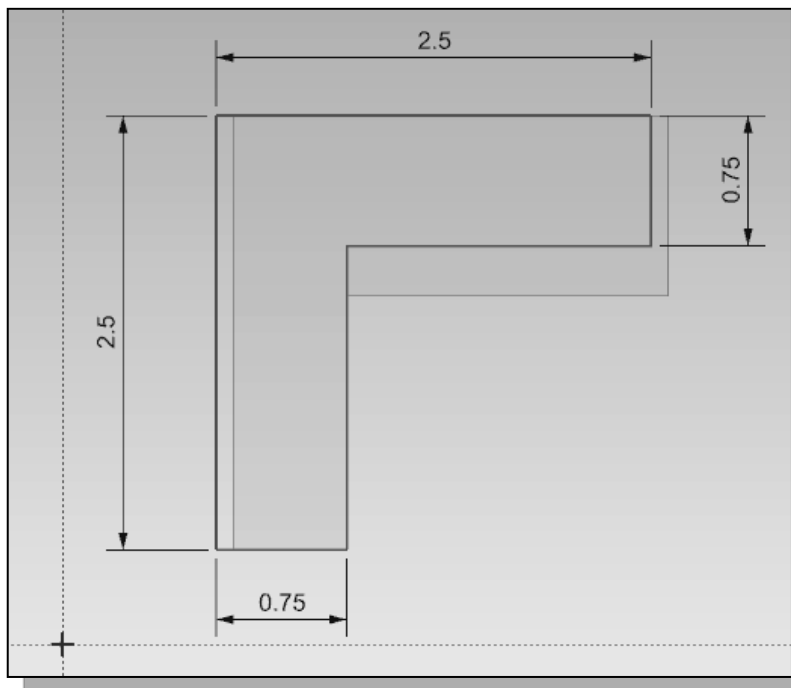

- ❖ In *Siemens NX*, this **Rapid Dimension** command is also known as the **Smart Dimension** command; dimensions are created based on the selection of the types and orientations of objects. You might want to read through this section again and consider the powerful implication of this command. Also consider this question: How would you create an *Angle dimension* using the *Rapid Dimension* command?

View Functions

- *Siemens NX* provides View related user interface called *View Toolbar* that enables convenient viewing of the entities in the graphics window.

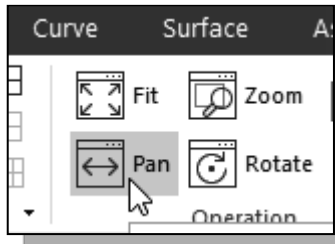
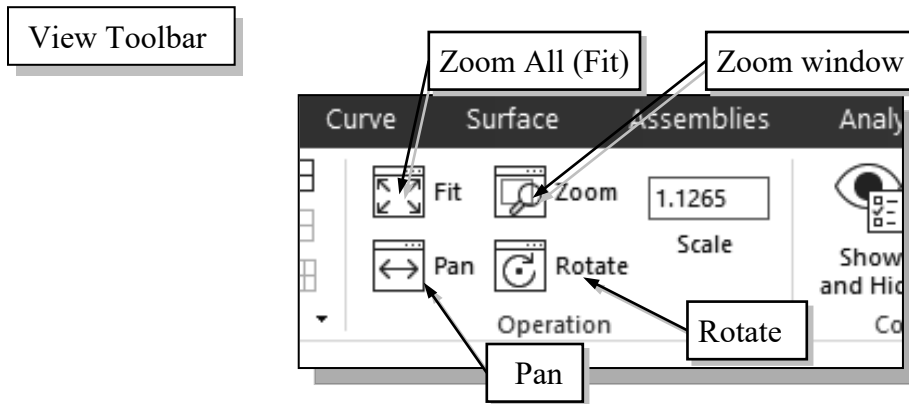

1. Click on the **Pan** icon, located in the *View Toolbar* as shown. The icon is the picture of a hand.

- The **Pan** command enables us to move the view to a different position. This function acts as if you are using a video camera.

Dynamic Viewing Functions

- *Siemens NX* also provides a special user interface called *Dynamic Viewing* through the use of the three mouse buttons.

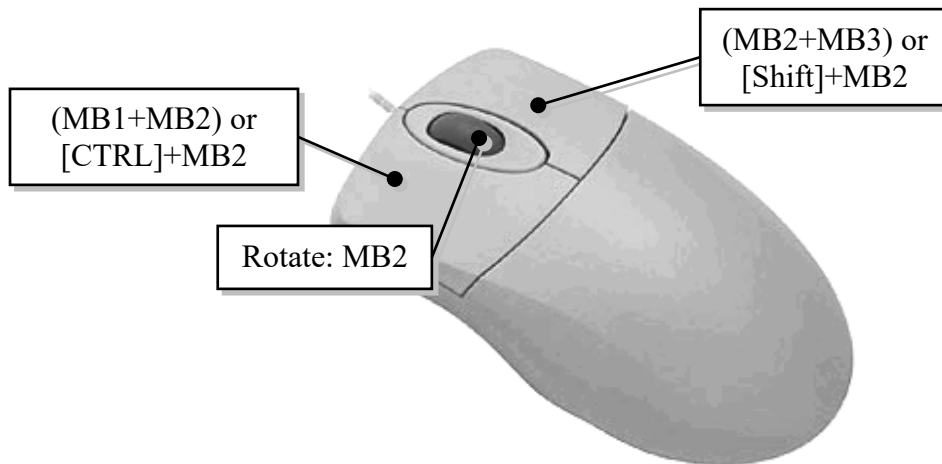

1. On your own, use the dynamic **Zoom** and **Pan** options by the mouse buttons to reposition the sketch near the center of the screen.

Step 5: Completing the Base Solid Feature

Now that the 2D sketch is completed, we will proceed to the next step: create a 3D part from the 2D section. Extruding a 2D section is one of the common methods that can be used to create 3D parts. We can extrude planar faces along a path. We can also specify a height value and a tapered angle. In *Siemens NX*, each face has a positive side and a negative side, and the current face we're working on is set as the default positive side. This positive side identifies the positive extrusion direction and it is referred to as the face's *normal*.

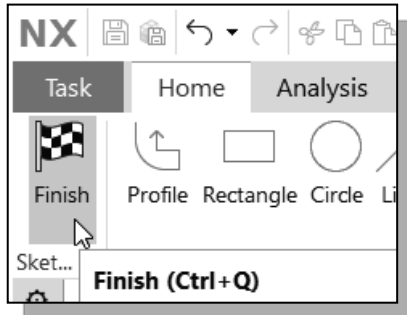

1. In the Home tab, select **Finish Sketch** by clicking once with the left-mouse-button (**MB1**) on the icon.

2. In the *Extrude* pop-up window, enter **2.5** as the extrusion distance. Notice that the sketch region is automatically selected as the extrusion section.

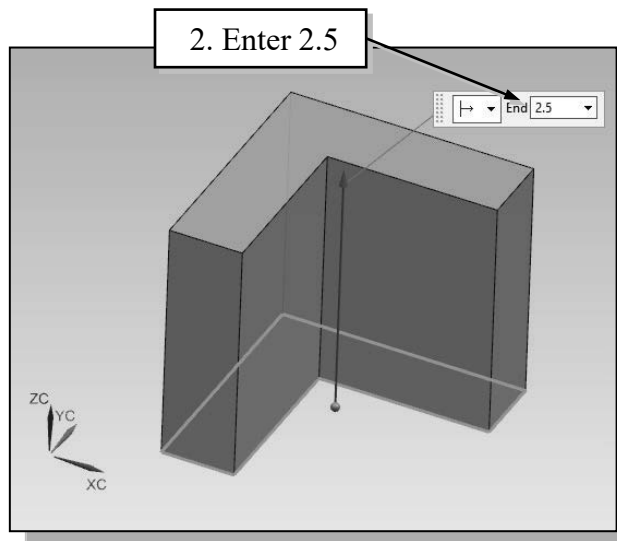

3. Click on the **OK** button to proceed with creating the 3D part.

- Note that all dimensions disappeared from the screen. All parametric definitions are stored in the *Siemens NX* **database** and any of the parametric definitions can be displayed and edited at any time.

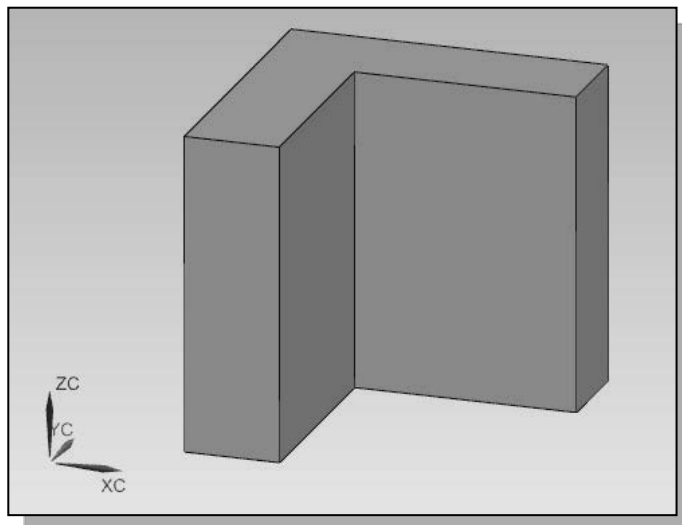

Display Orientations

- ❖ *Siemens NX* provides many ways to display views of the three-dimensional design. Several options are available that allow us to quickly view the design to track the overall effect of any changes being made to the model. We will first orient the model to display in the *Front view*, by using the *Option menu*.

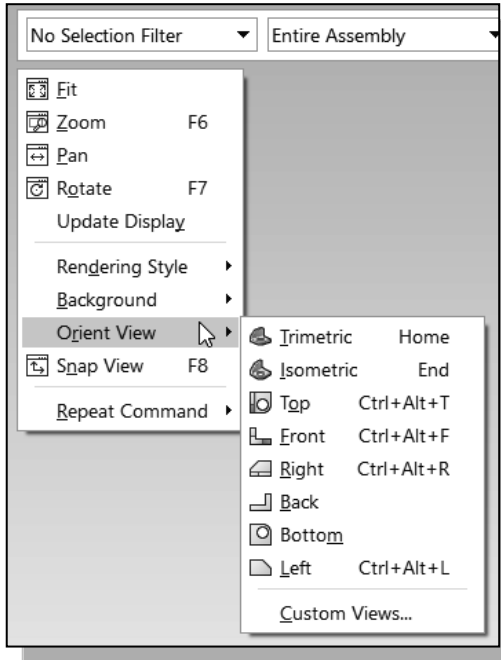

1. Inside the graphic window, right-click once to bring up the *Option menu*. Select the *Orient View* as shown.
2. Select **Front View** in the *Orient View List* to change the display to the front view. (Note that **[Ctrl+Alt+F]** can also be used to activate this command.)

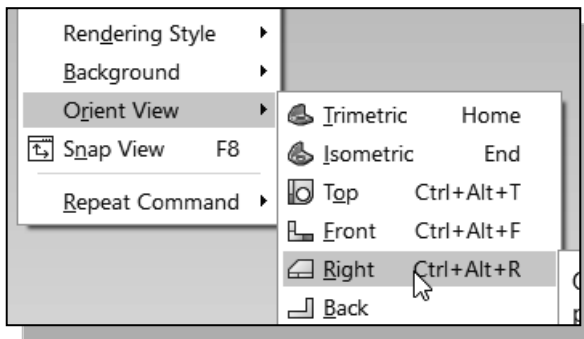
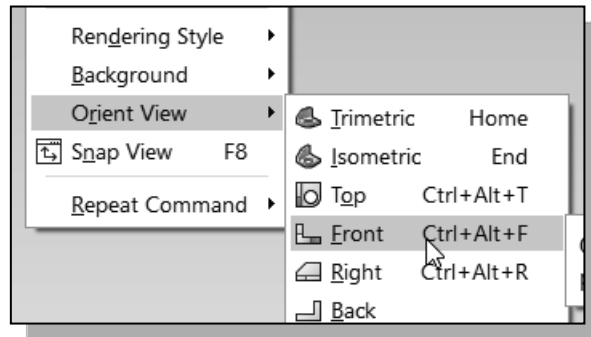

3. Inside the graphic window, right-click once to bring up the *Option menu*. Select **Right View** in the *Orient View List* to change the display to the right side view. (Note that the quick-key **[Ctrl+Alt+R]** can also be used to activate this command.)

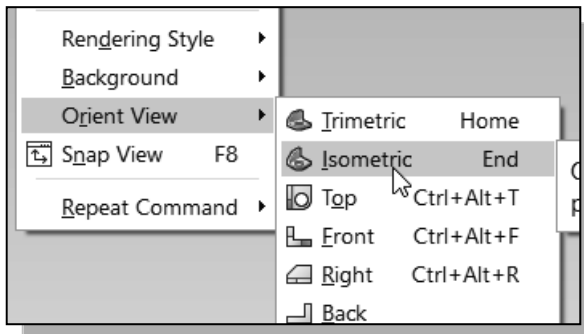

4. Inside the graphic window, right-click once to bring up the *Option menu*. Select **Isometric View** in the *Orient View List* to change the display to the isometric view. (Note that the **[End]** key can also be used to activate this command.)

- ❖ Notice the other view-related commands that are available under the *Orient View Drop-Down menu*.

Dynamic Viewing – Icons, Mouse buttons and Quick keys

- The *3D Rotate* icon can be found in the View toolbar or use the right-click option menu. *3D Rotate* enables us to manipulate the view of 3D objects by clicking and dragging with the left-mouse-button:

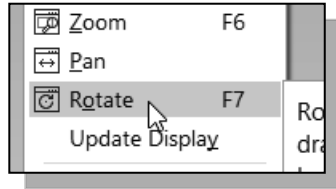

1. Inside the graphic window, right-click once to bring up the *Option menu*. Click on the **Rotate** icon in the *list*.
 2. Drag with the left-mouse-button (**MB1**) for free rotation of the 3D model.
3. Press the [**F7**] key (toggle switch) once to exit the 3D rotate command.

- We can also use the mouse buttons to access the *Dynamic Viewing* functions.

❖ 3D Dynamic Rotation – The Middle-Mouse-Button (MB2)

Hold and drag with the middle-mouse-button to rotate the display interactively.



❖ Panning – (1) The Middle and Right Mouse Buttons

Hold and drag with the middle and right mouse buttons (MB2+MB3) to pan the display. This allows you to reposition the display while maintaining the same scale factor of the display.

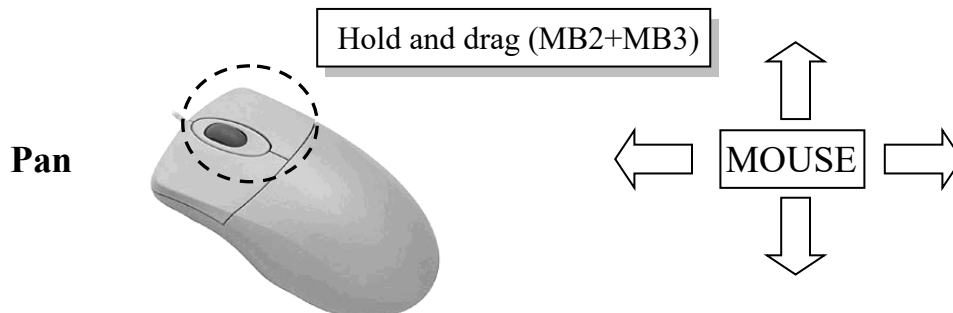

(2) [Shift] + [Middle-mouse-button (MB2)]

Hold the [**Shift**] key and the [**middle-mouse-button(MB2)**] to pan the display.

❖ **Zooming – (1) The Left and Middle Mouse Buttons**

Hold and drag with the left and middle mouse buttons (MB1+MB2) vertically on the screen to adjust the scale of the display. Moving upward will magnify the scale of the display, making the entities display larger on the screen. Moving downward will reduce the scale of the display.

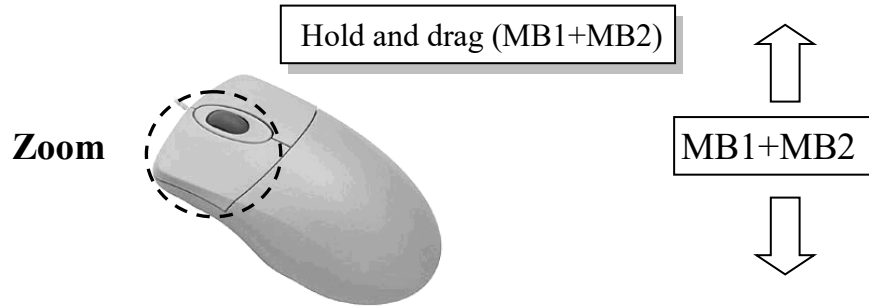

(2) [Shift] + [Middle mouse button (MB2)]

Hold the [Shift] key and the [middle-mouse-button (MB2)] to pan the display.

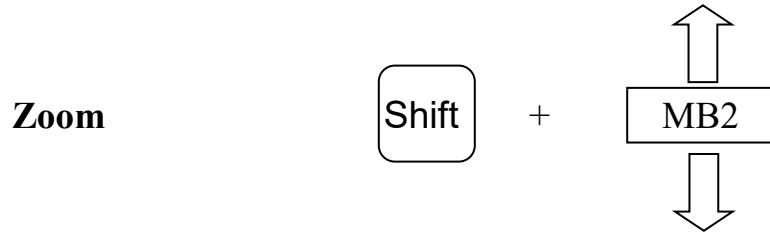

(3) Turning the mouse wheel



Turning the mouse wheel can also adjust the scale of the display. Turning forward will reduce the scale of the display, making the entities display smaller on the screen. Turning backward will magnify the scale of the display.

➤ Note that the *dynamic viewing* functions are also available through the **Right-Mouse-Click Option Menu**.

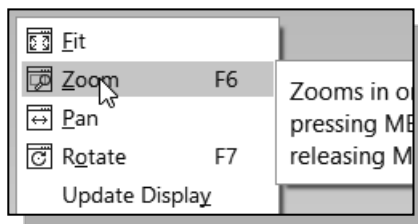
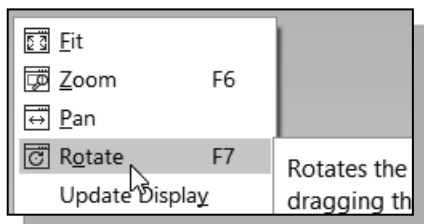

Display Modes

- The display in the graphics window has two basic display-modes: wireframe and shaded display. To change the display mode in the active window, right-click once to bring up the *Option menu* and choose the **Rendering Style** option as shown.

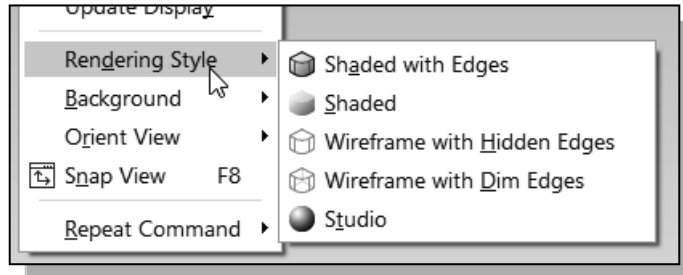

- Inside the graphic window, right-click once to bring up the *Option menu*. choose the **Rendering Style** option as shown.

- Pick the **Wireframe with Dim Edges** option as shown in the figure.

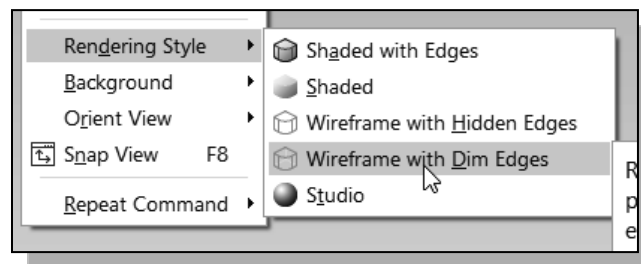
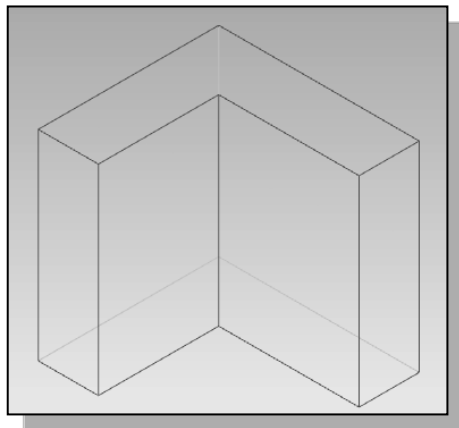

❖ Wireframe with Dim Edges

This display mode generates an image of the 3D object with all the back lines shown as lighter edges.

- Pick the **Shaded with Edges** option as shown.

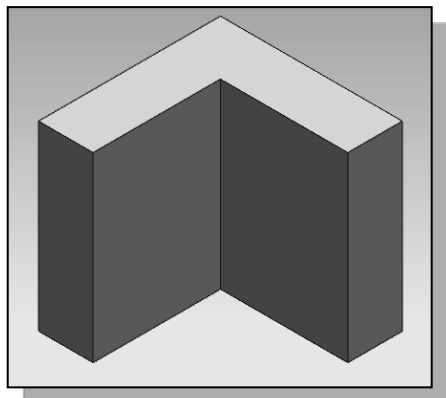
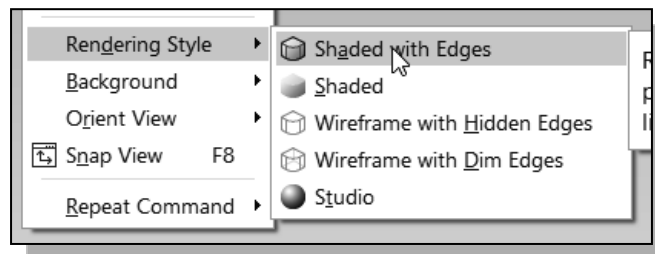

❖ Shaded with Edges

This display mode option generates a shaded image of the 3D object with the edges highlighted.

- On your own, use the different options to familiarize yourself with the 3D viewing/display commands.

Step 6-1: Adding an Extruded Feature

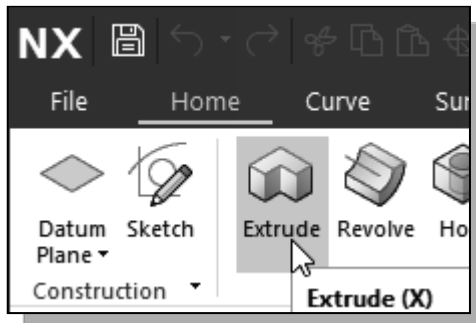

1. In the **Feature Toolbar** (toolbar next to the **Sketch** toolbar in the **Ribbon Bar**), select the **Extrude** icon as shown.

2. In the **Message** area, the message “*Select planar face to sketch or select section geometry*” is displayed. *Siemens NX* expects us to identify a planar surface where the 2D sketch of the next feature is to be created. Move the graphics cursor on the 3D part and notice that *Siemens NX* will automatically highlight feasible planes and surfaces as the cursor is on top of the different surfaces. Pick the back vertical face of the 3D solid object, with the new *work coordinate* aligned to the upper left corner, as shown.

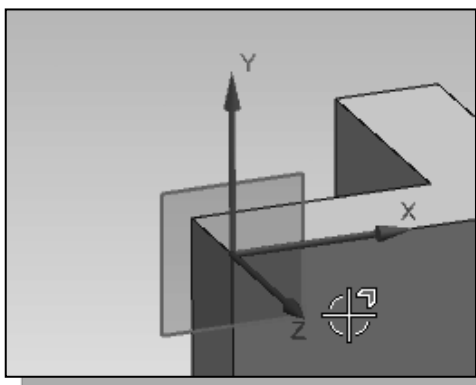
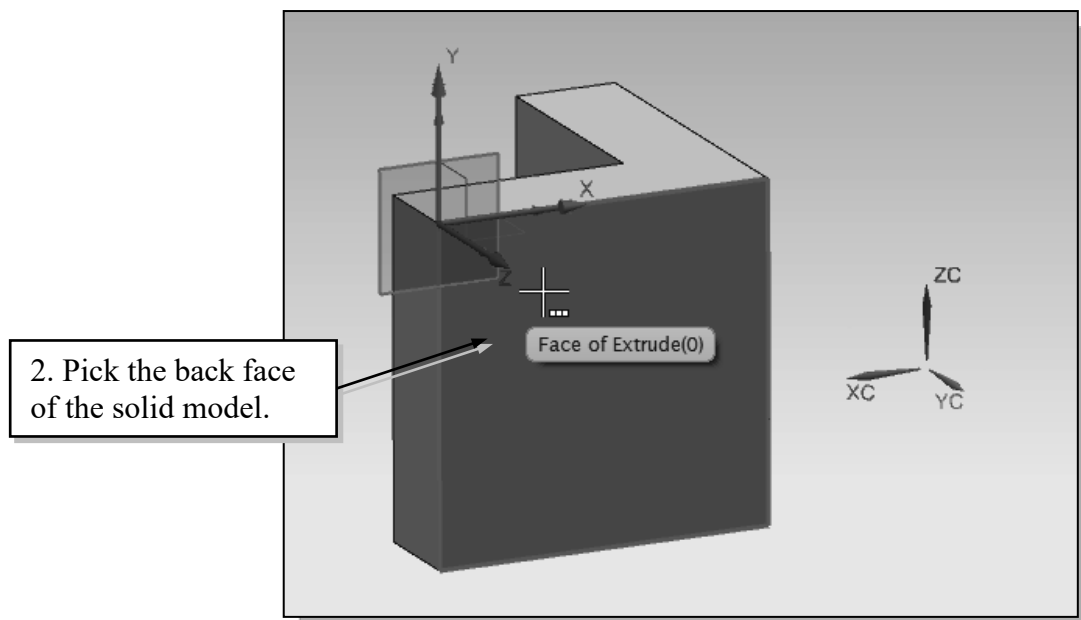

- Note that the sketch plane is aligned to the selected face. *Siemens NX* automatically establishes a **Work-Coordinate-System (WCS)** and records its location with respect to the part on which it was created.

- Next, we will create another 2D sketch, which will be used to create another extrusion feature that will be added to the existing solid object.
3. On your own, create a 2D sketch consisting of horizontal/vertical lines as shown in the below figure. Note that we are intentionally not aligning the new sketch to any of the corners of the existing 3D model.

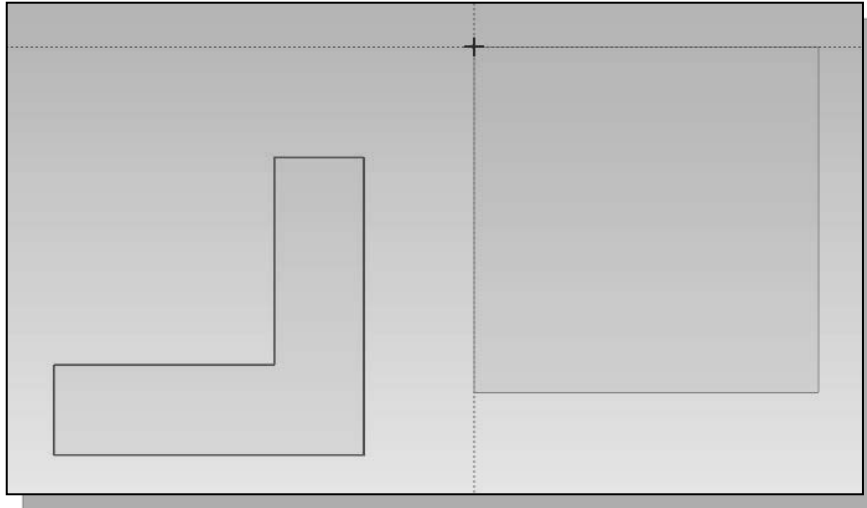

4. Create and modify the four size dimensions to describe the size of the sketch as shown. (Note that Siemens NX will maintain the right amount of dimensions to the sketch without over-constraining the sketch.)

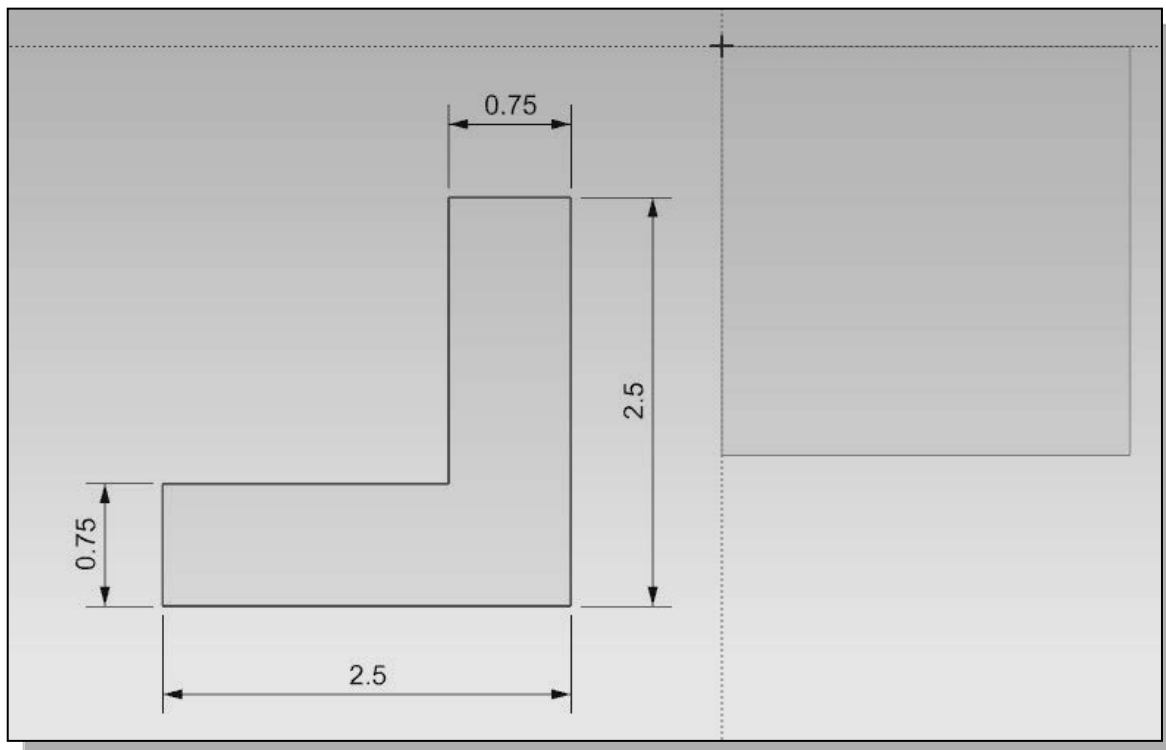

5. Create and modify the two location dimensions to **0.0**; this will align the position of the sketch relative to the top corner of the solid model as shown.

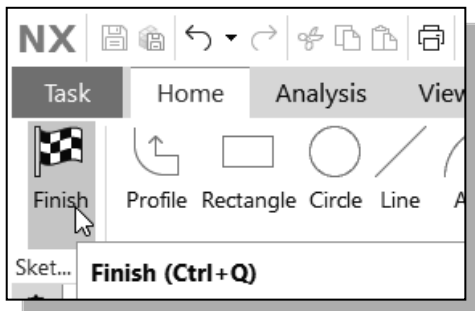
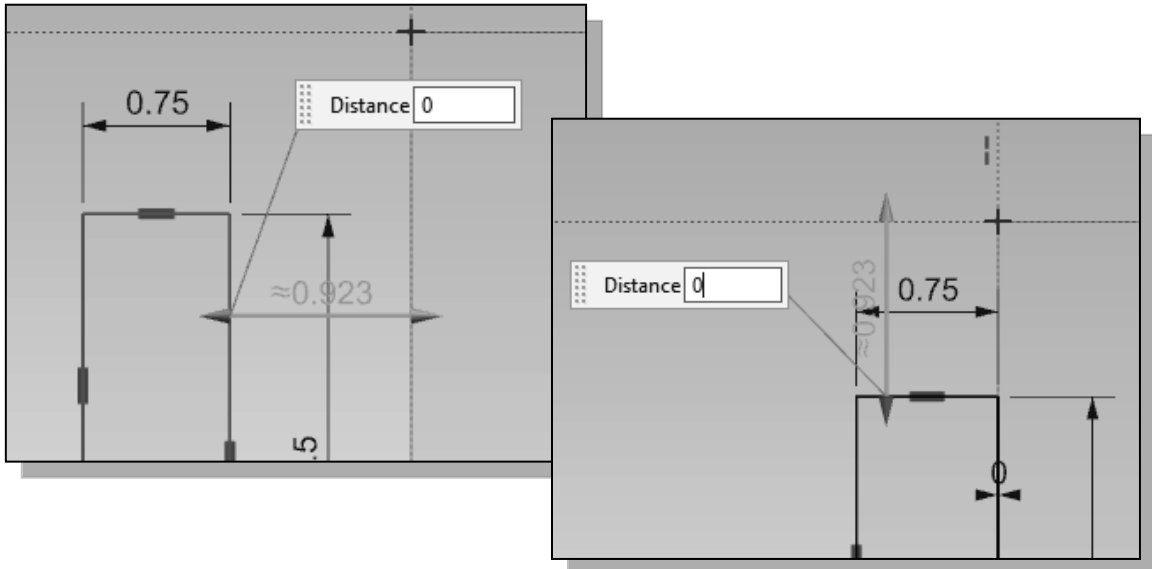

6. Select **Finish Sketch** by clicking once with the left-mouse-button (MB1) on the icon.

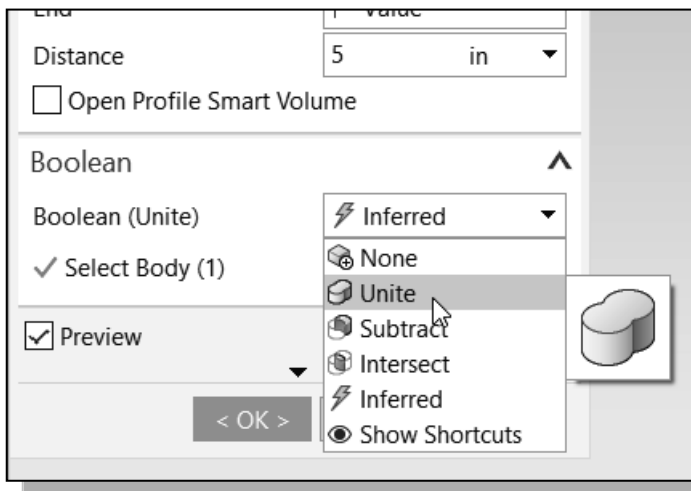

7. In the *Extrude* pop-up window, select **Unite** as the *Extrude Boolean* option.

- The **Unite** option will **ADD** the new feature to the existing solid. Note that the default option was set to **Inferred**, which means Siemens NX will determine the option based on the type of sketches created.

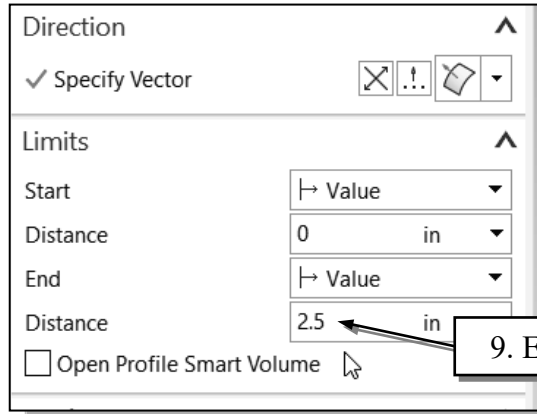

8. In the *Extrude* pop-up window, enter **2.5** as the extrusion distance.

9. Use the **Reverse Direction** icon to toggle the extrusion direction so that the extrusion appears as shown in the figure.

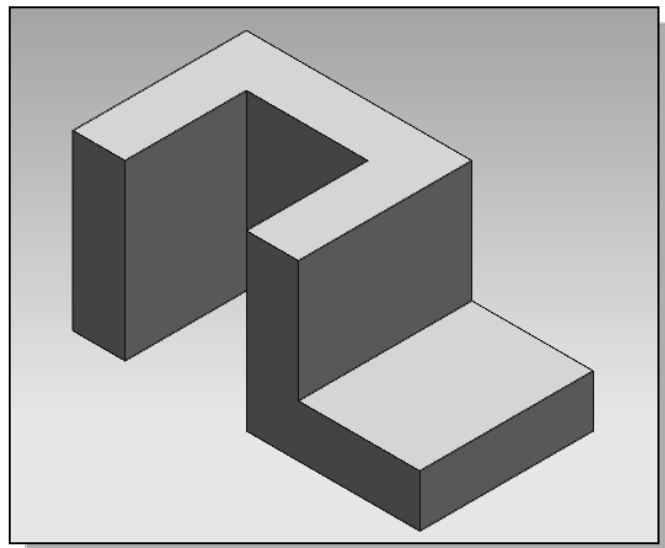
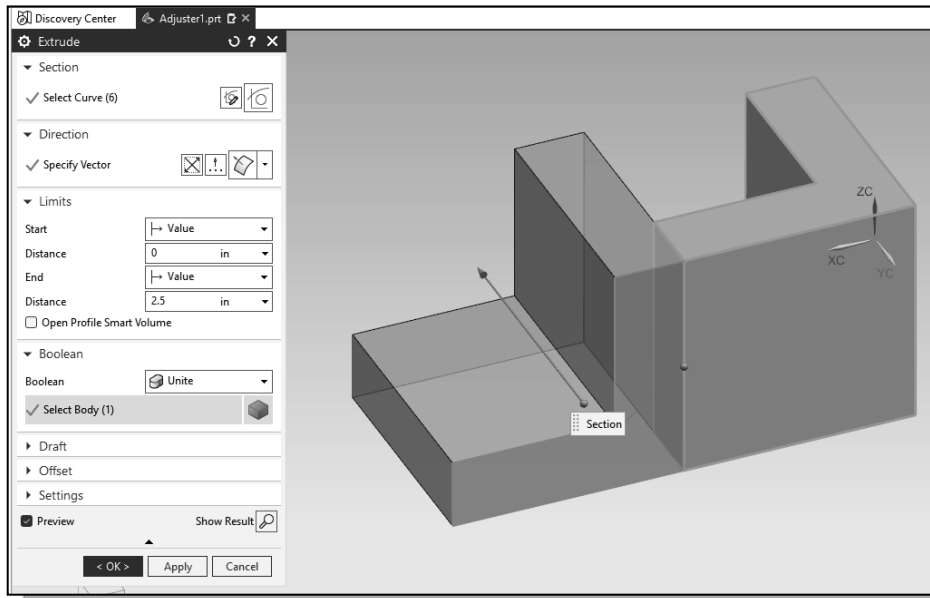

10. Click on the **OK** button to proceed with creating the 3D feature.

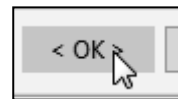

Step 6-2: Adding a Cut Feature

- Next, we will create and profile a circle, which will be used to create a **cut** feature that will be added to the existing solid object.

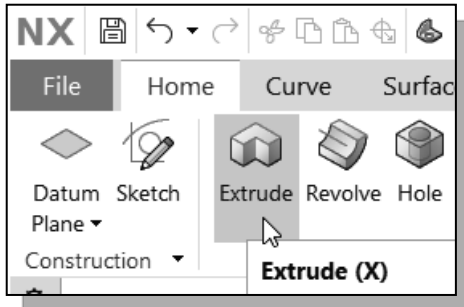

1. In the **Feature Toolbar** (toolbar next to the **Sketch** toolbar in the **Ribbon Bar**), select the **Extrude** icon as shown.

2. In the **Message** area, the message “*Select planar face to sketch or select section geometry*” is displayed. *Siemens NX* expects us to identify a planar surface where the 2D sketch of the next feature is to be created. Move the graphics cursor on the 3D part and notice that *Siemens NX* will automatically highlight feasible planes and surfaces as the cursor is on top of the different surfaces. Pick the horizontal face of the 3D solid object, with the **Work Coordinate System** aligned to the left corner as shown.

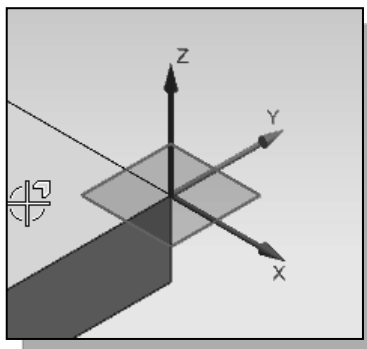
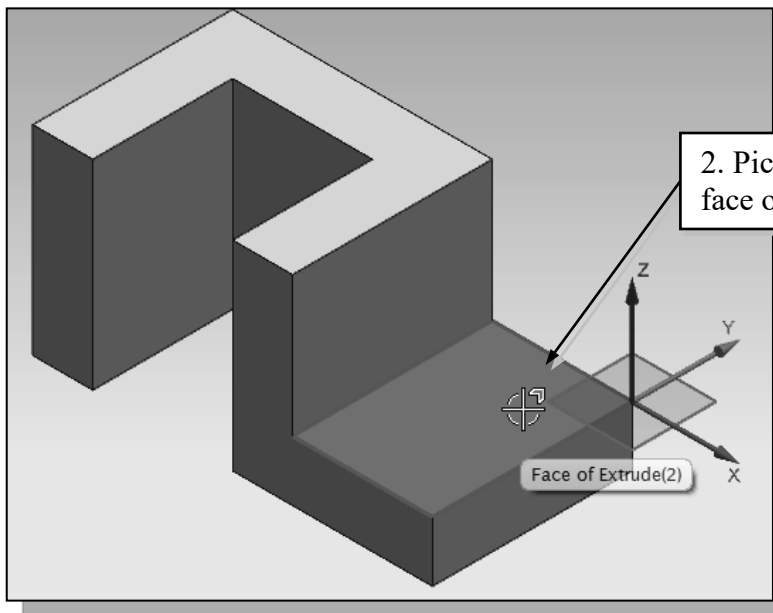

- Note that the sketch plane is aligned to the selected face. *Siemens NX* automatically establishes a *Work-Coordinate-System* (WCS) and records its location with respect to the part on which it was created.

3. Select the **Circle** command by clicking once with the **left-mouse-button (MB1)** on the icon in the *Sketch Curve* toolbar.

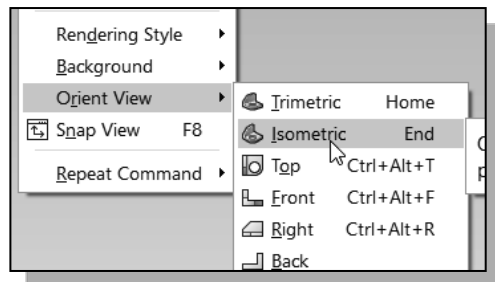
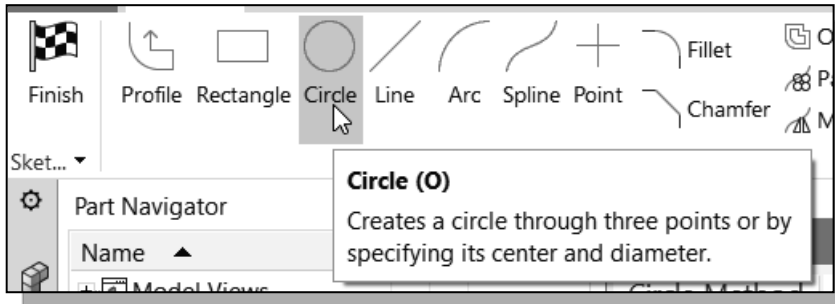

4. Reset the display to the *Isometric* view display as shown.

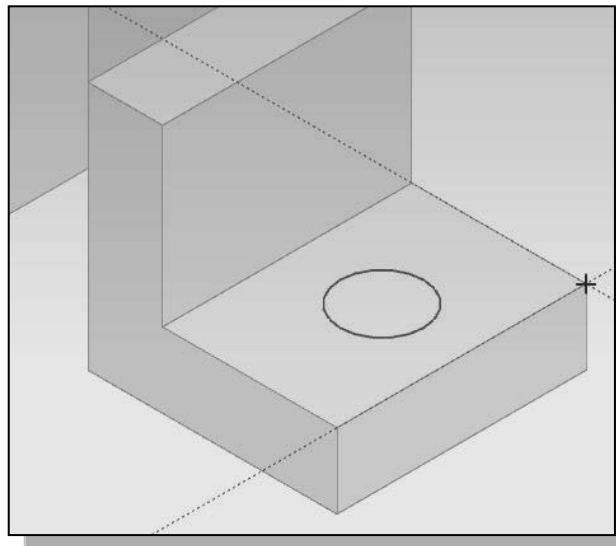

5. Create a circle of arbitrary size on the horizontal face of the solid model as shown.

6. Select the **center point** of the circle and the **top edge** of the base to create the location dimension as shown. Set the dimension to **1.25** as shown.

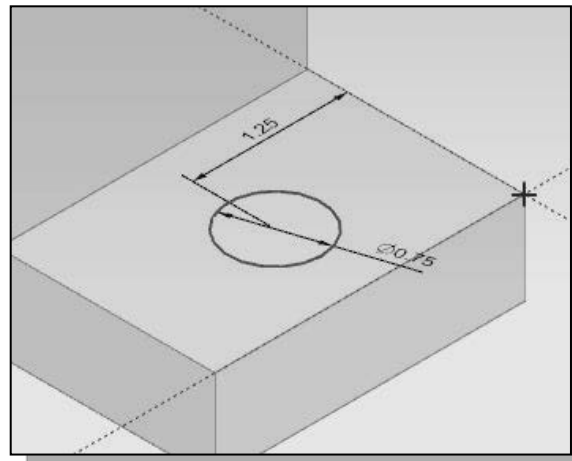
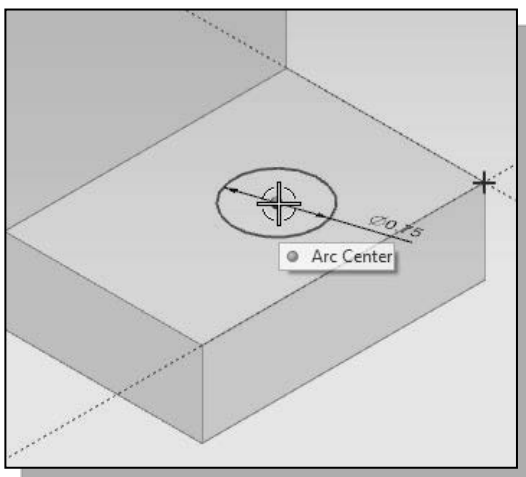

- On your own, create and modify the other location dimension to 0.75, as shown in the figure. (Hint: there are two locational dimensions and one size dimension.)

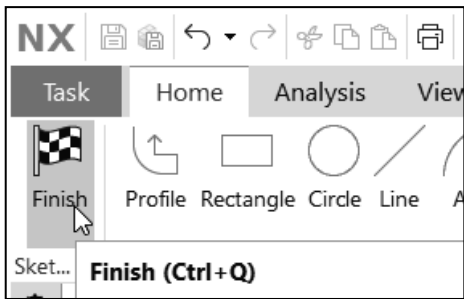
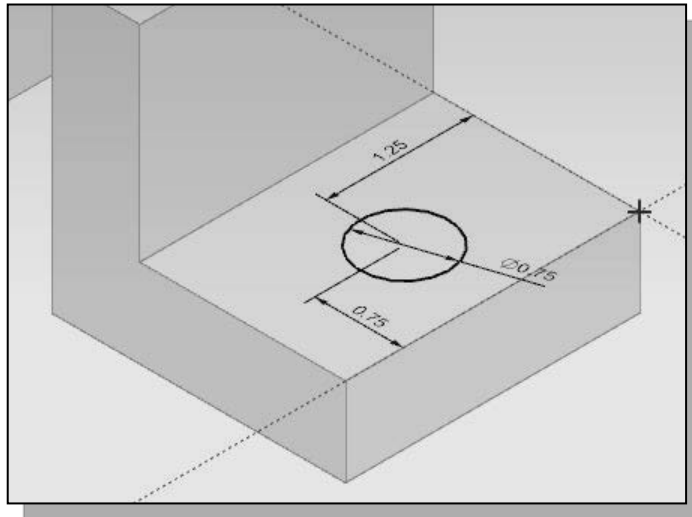

- Select **Finish Sketch** by clicking once with the left-mouse-button (MB1) on the icon.

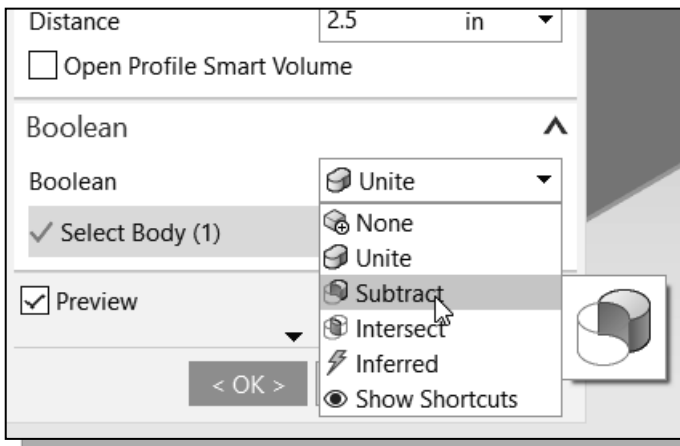

- In the *Extrude* pop-up window, select **Subtract** as the *Extrude Boolean* option.

➤ The **Subtract** option will **Remove** the volume of the new feature to the existing solid. Note that the default option was set to **Unite**, which will add the feature to the existing solid model.

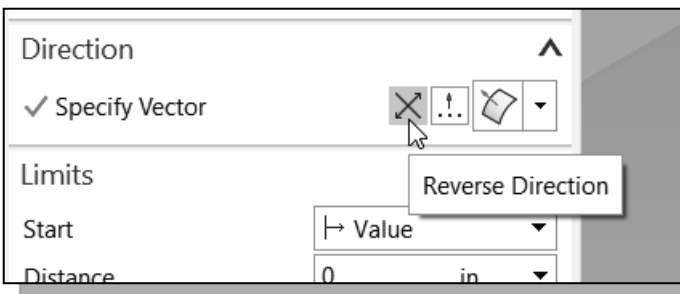

- In the *Direction* option box, use the **Reverse Direction** icon to toggle the extrusion direction so that the extrusion cut through the bottom section of the model.

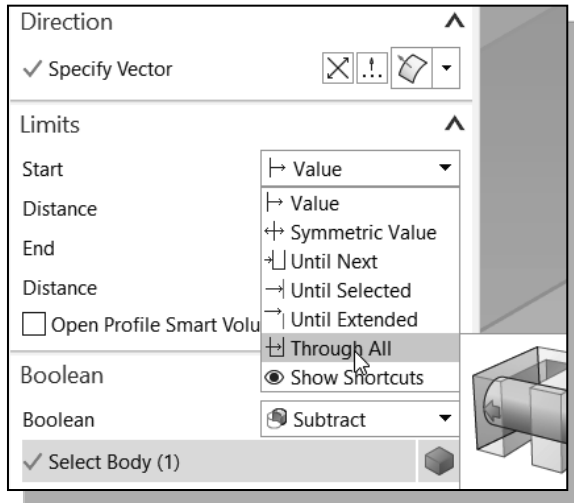

11. In the *Limits* option box, choose the **Through All** option to set the *Start* extrusion limit.

12. Click on the **OK** button to proceed with creating the 3D feature.



Step 6-3: Adding another Cut Feature

- Next, we will create and profile a triangle, which will be used to create another **cut** feature that will be added to the existing solid object.

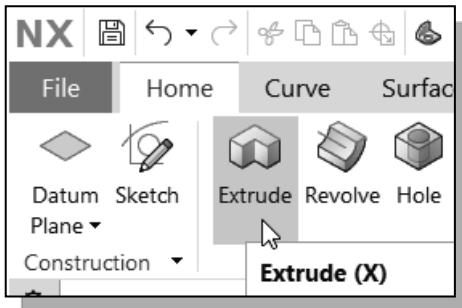

1. In the *Feature Toolbar* (toolbar next to the *Sketch* toolbar in the *Ribbon Bar*), select the **Extrude** icon as shown.

2. Pick the vertical face of the 3D solid object, with the Work Coordinate system aligned to the left corner as shown.

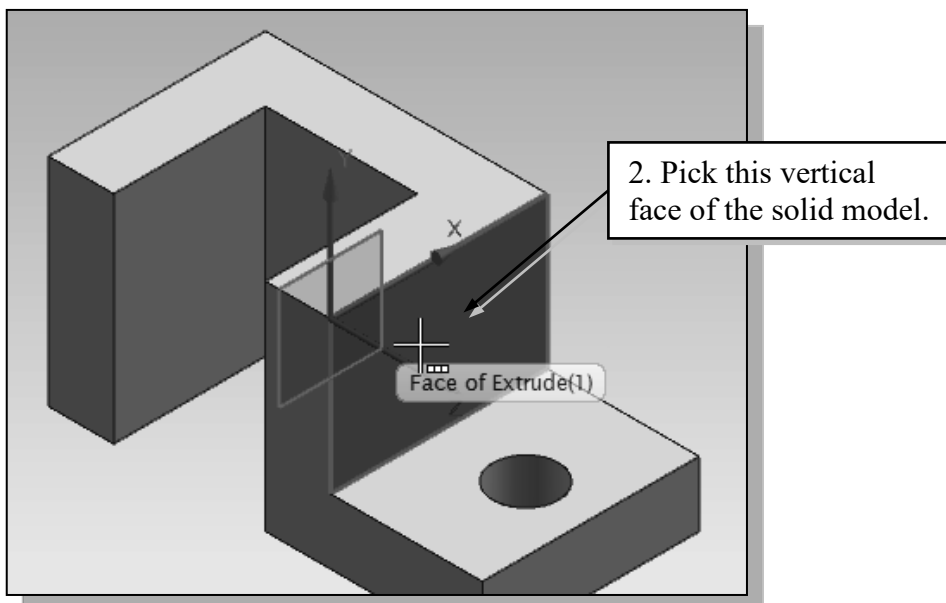

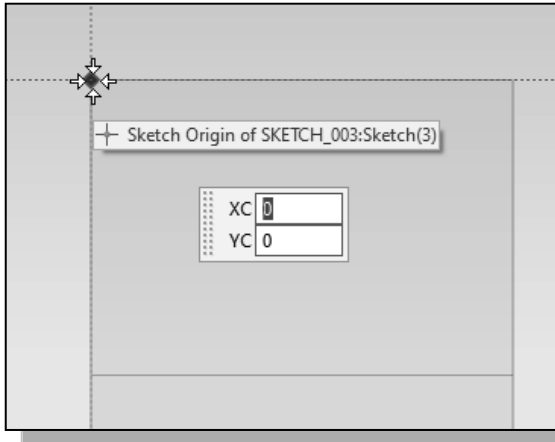

- Use the **Profile** command and start the first line segment at the top left corner (the sketch Origin) as shown.

- Place the second point aligned to and **below** the previous point as shown.

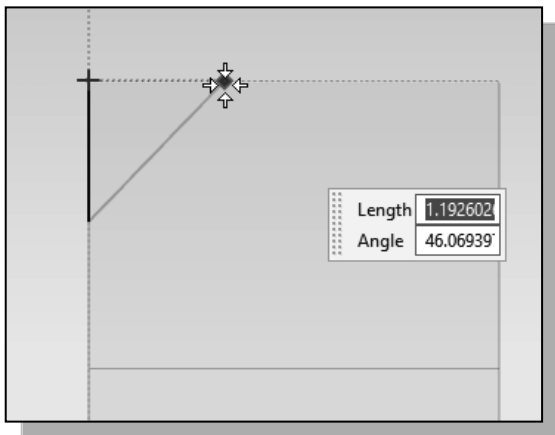
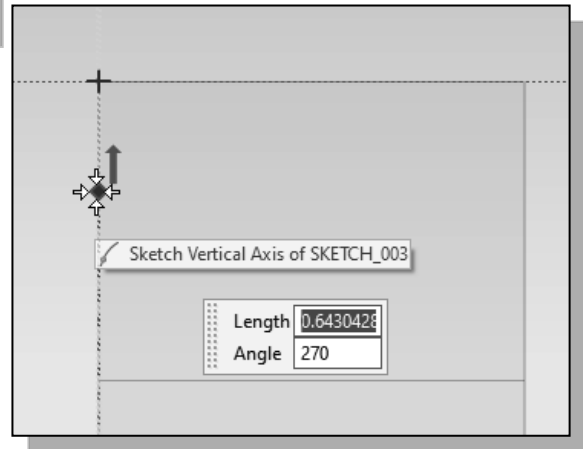

- Place the second point aligned to and to the right of the sketch origin as shown.

- Complete the profile by connecting to the first point as shown.

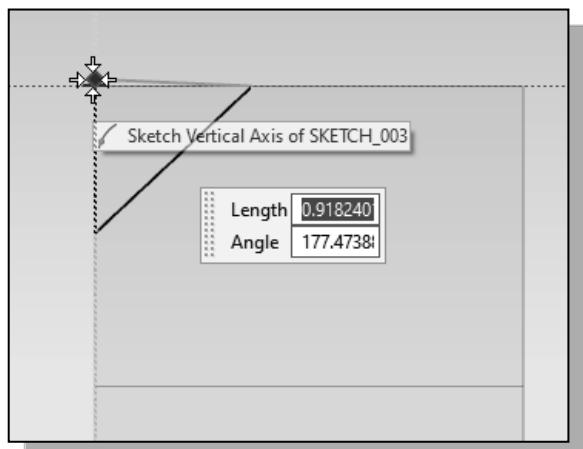

7. On your own, create and modify the linear dimension on top as shown.

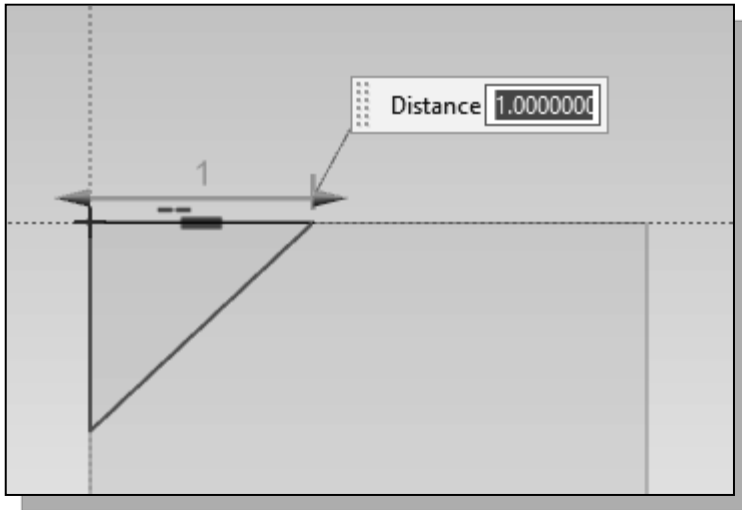

8. Select the two sketched line segments and place the angular dimension inside the triangle to create the associated angle dimension.

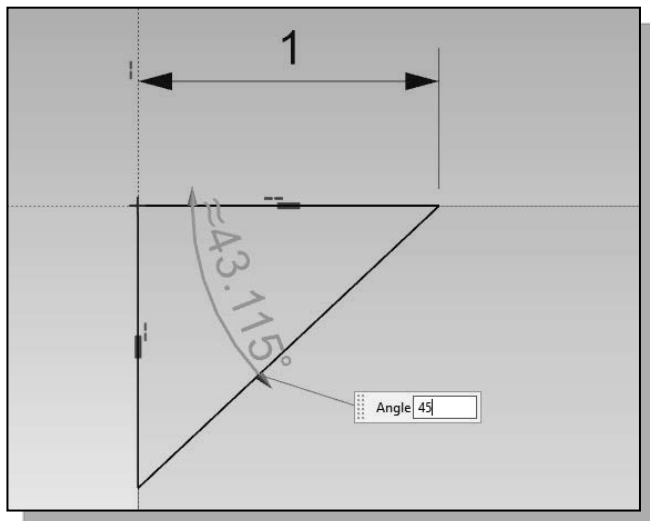
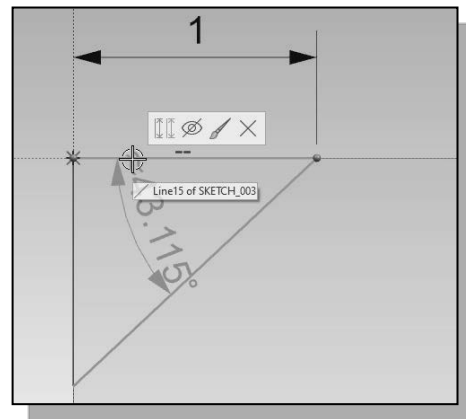
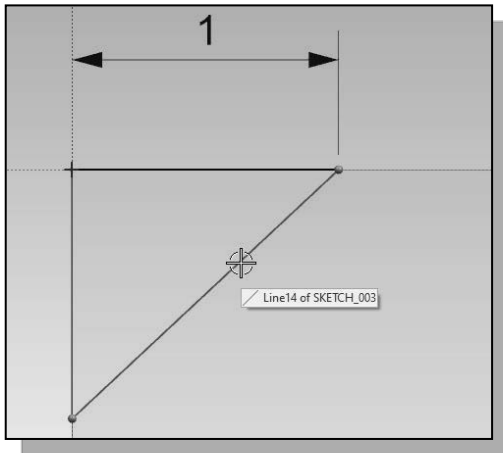

9. On your own, modify the dimension to 45 as shown.

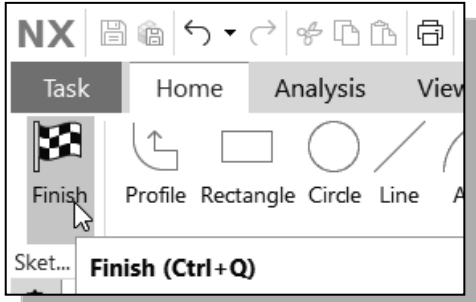

10. Select **Finish Sketch** by clicking once with the left-mouse-button (MB1) on the icon.

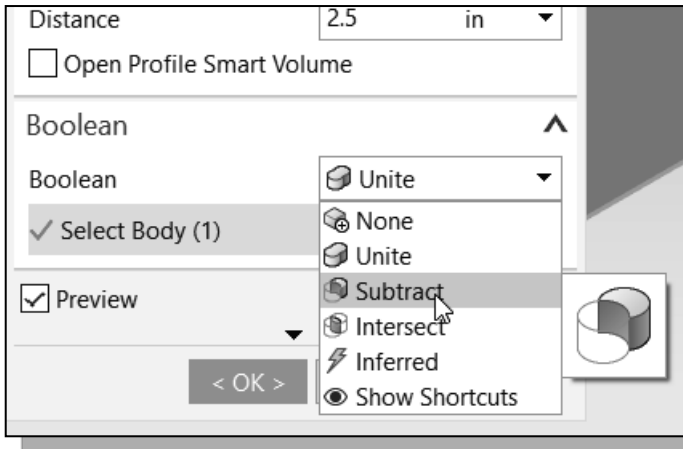

11. In the *Extrude* pop-up window, select **Subtract** as the *Extrude Boolean* option.

➤ The **Subtract** option will **Remove** the volume of the new feature to the existing solid. Note that the default option was set to **unite**, which will add the new feature to the existing solid model.

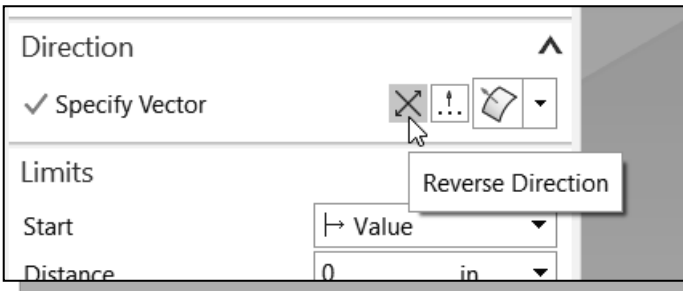

12. In the *Direction* option box, use the **Reverse Direction** icon to toggle the extrusion direction so that the extrusion cut through the bottom section of the model.

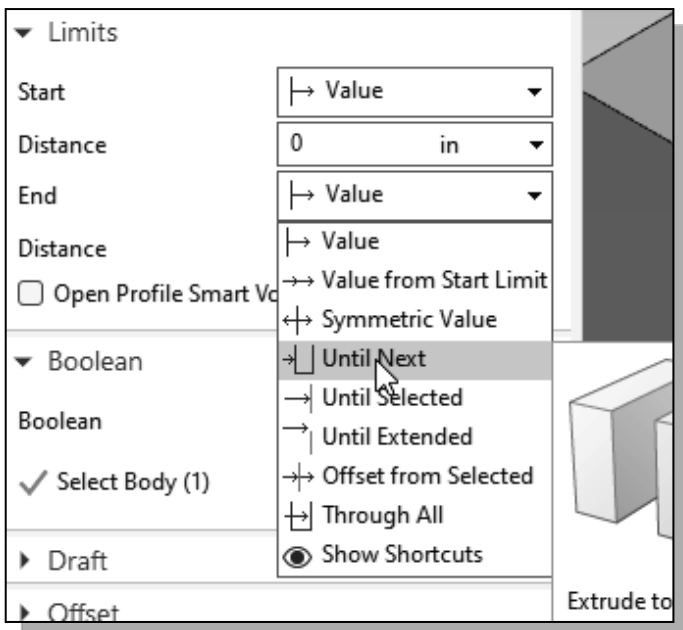

13. In the *Limits* option box, choose the **Until Next** option to set the *End* extrusion limit.

14. Click on the **OK** button to proceed with creating the 3D feature.



- On your own, use the dynamic viewing functions and examine the completed solid model.

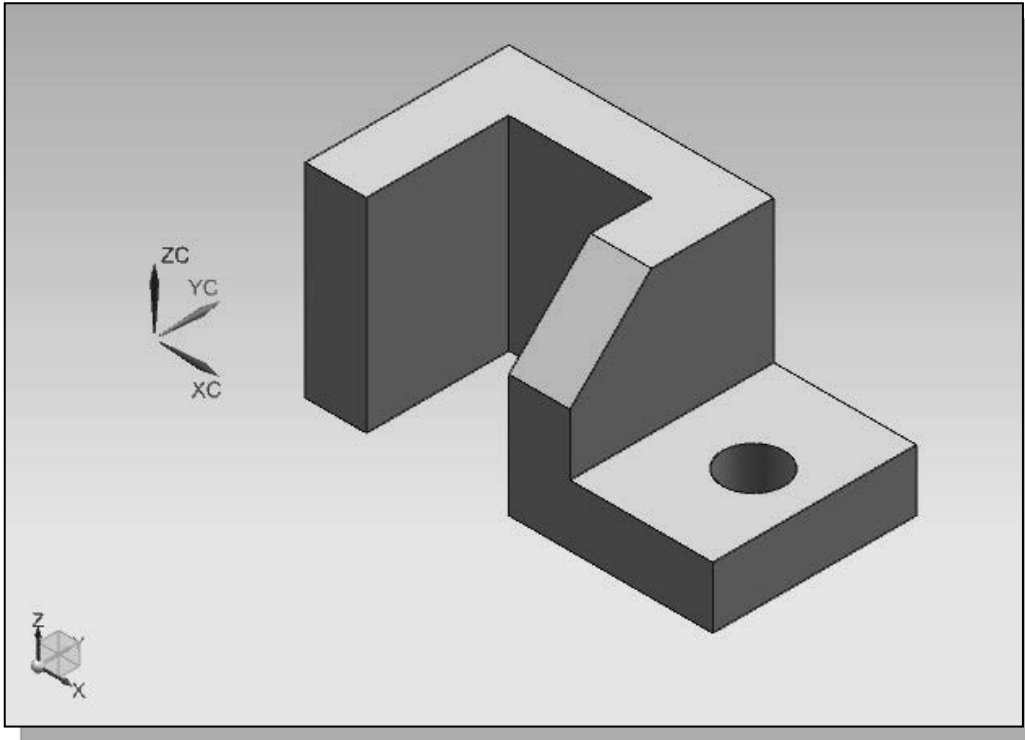

Save the Model and Exit Siemens NX

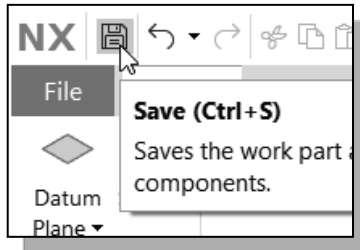

1. Select **Save** in the *quick access* menu, or you can also use the “**Ctrl+S**” key combination (hold down the “**Ctrl**” key and hit the “**S**” key once) to save the part.

- ❖ You should form a habit of saving your work periodically, just in case something might go wrong while you are working on it. In general, one should save one’s work at an interval of every 15 to 20 minutes. One should also save before making any major modifications to the model.

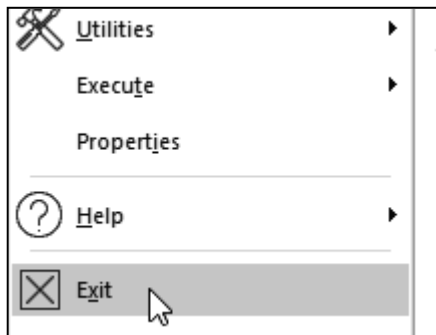

2. Select **Exit** in the *File* pull-down menu to exit Siemens NX.

Review Questions:

1. What is the first thing we should set up in *Siemens NX* when creating a new model?
2. Describe the general *parametric modeling* procedure.
3. List two of the geometric constraint symbols used by *Siemens NX*.
4. What was the first feature we created in this lesson?
5. Describe the steps required to define the orientation of the sketching plane.
6. How do we change the size of 2D geometry in the 2D sketcher mode?

Exercises: (All dimensions are in inches.)

1. Plate Thickness: **.25**

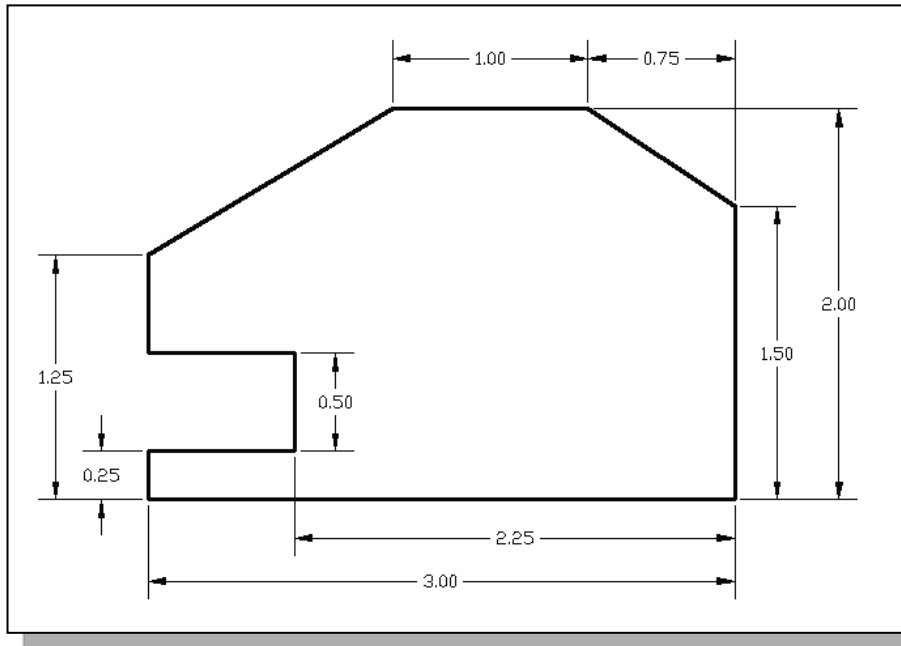

2. Plate Thickness: **.5**

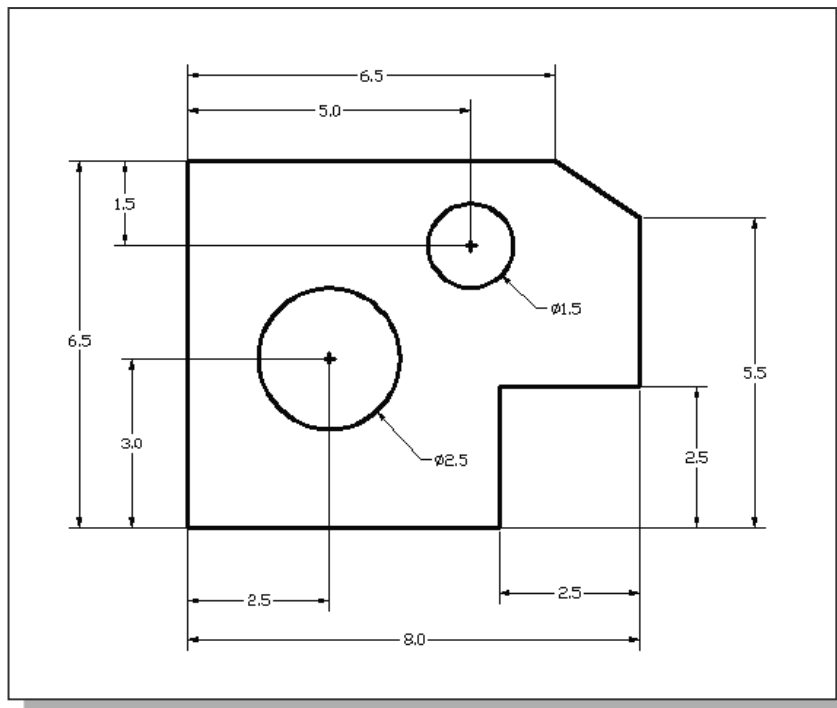

3.

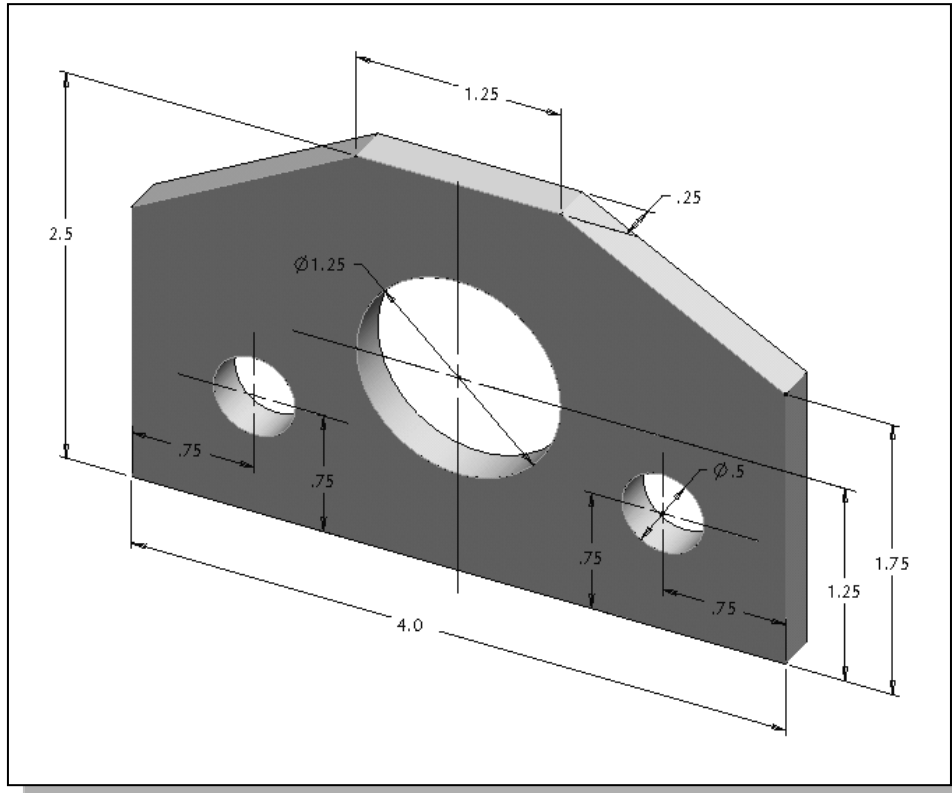

4.

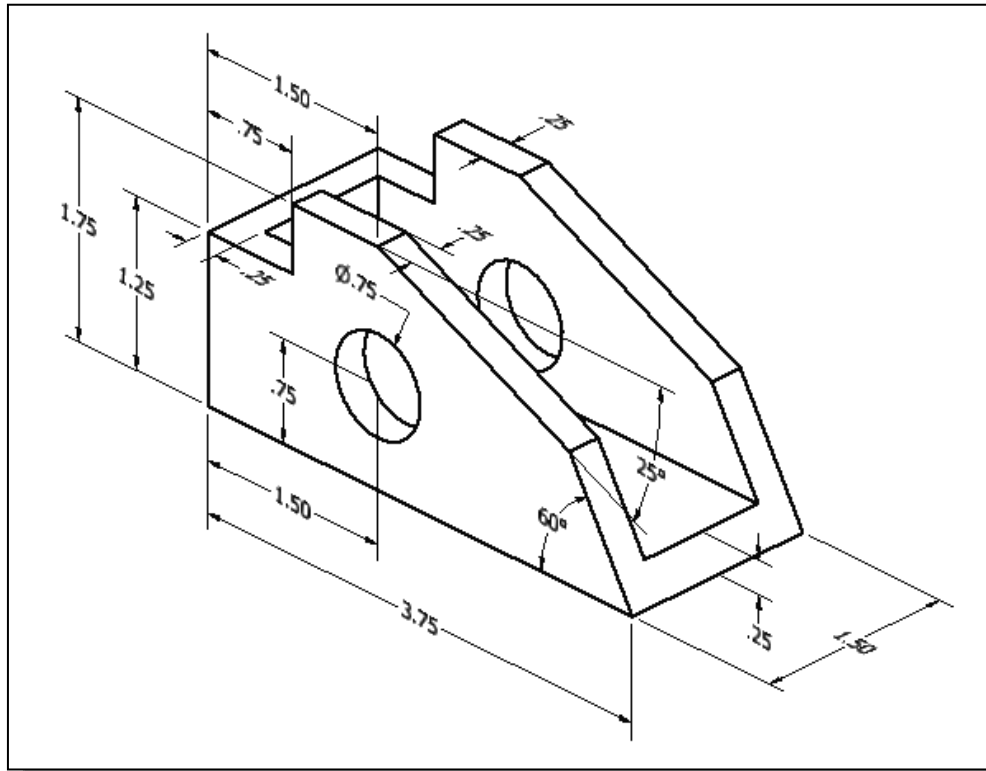

5.

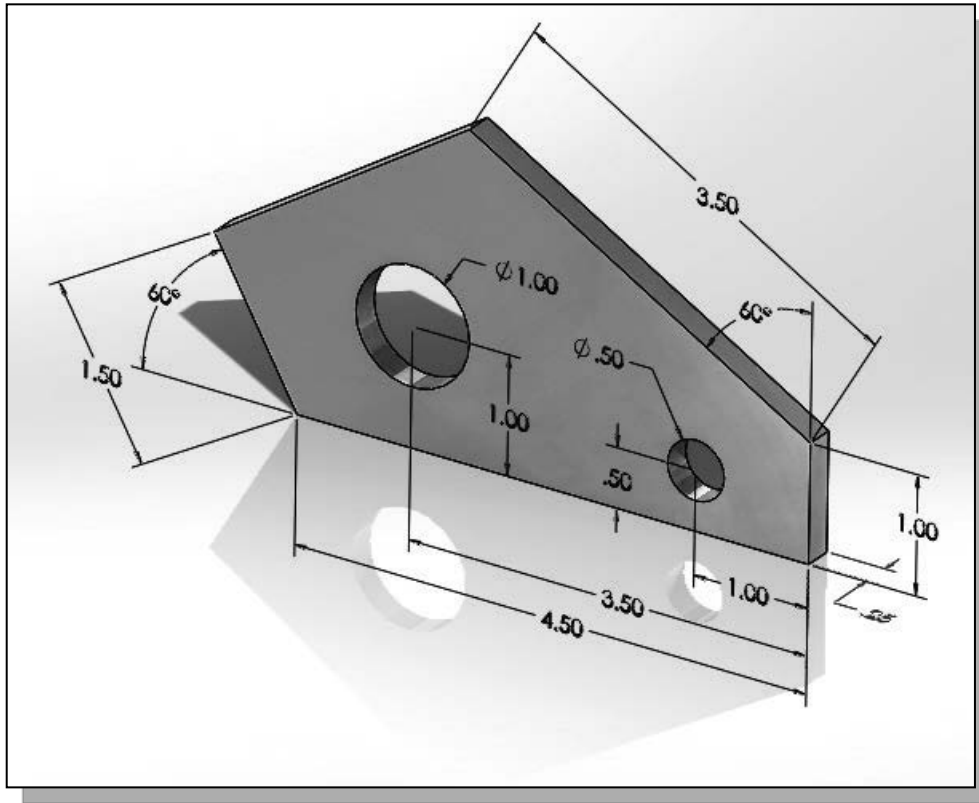

6.

