

Engineering Graphics with SOLIDWORKS® 2025

A Step-by-Step Project Based Approach

Includes
SOLIDWORKS and
3DEXPERIENCE eBook

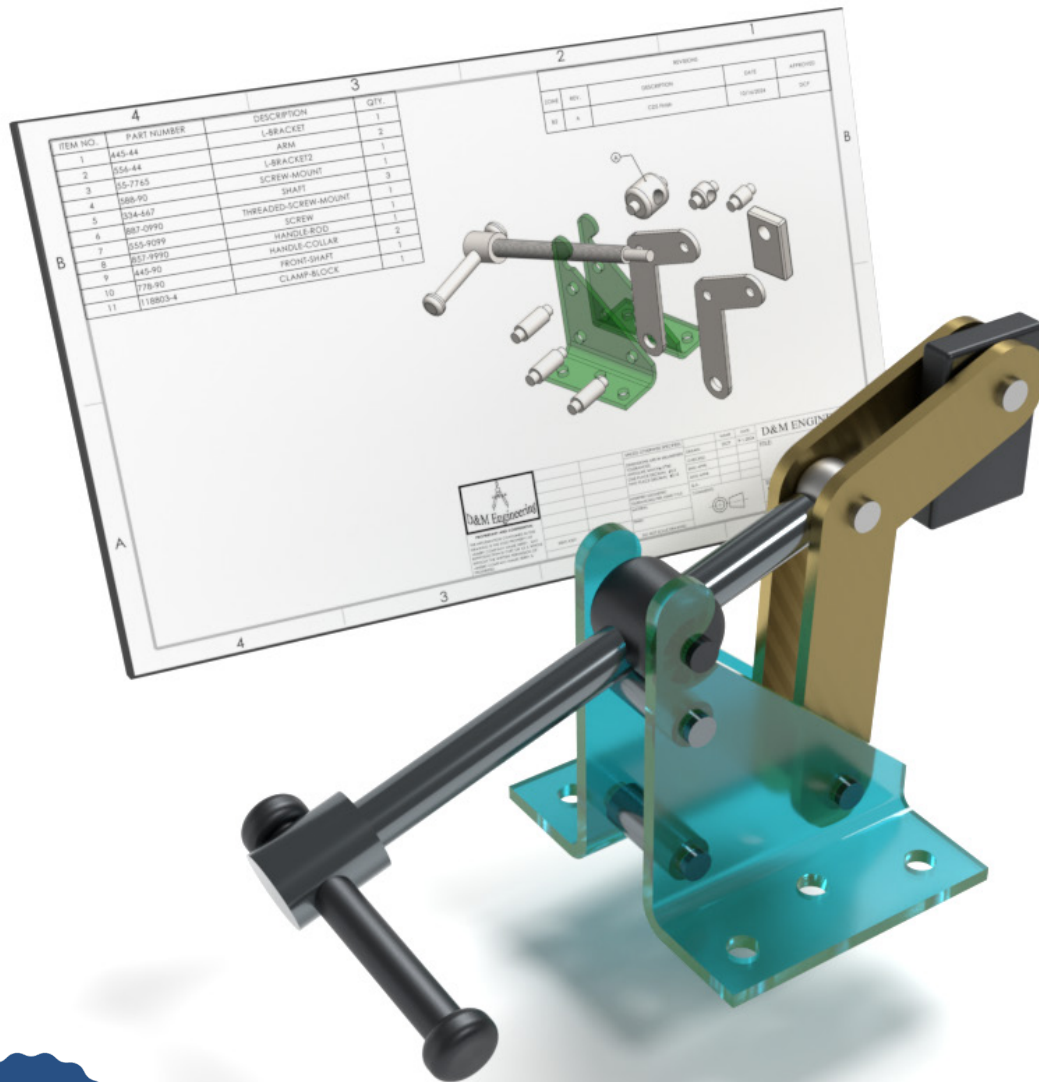

David C. Planchard, CSWP,
SOLIDWORKS Accredited Educator



Better Textbooks. Lower Prices.
www.SDCpublications.com



ACCESS CODE
UNIQUE CODE INSIDE

Visit the following websites to learn more about this book:



[amazon.com](https://www.amazon.com)

[Google books](https://books.google.com)

[BARNES & NOBLE](https://www.barnesandnoble.com)

Chapter 2

Isometric Projection and Multi View Drawings

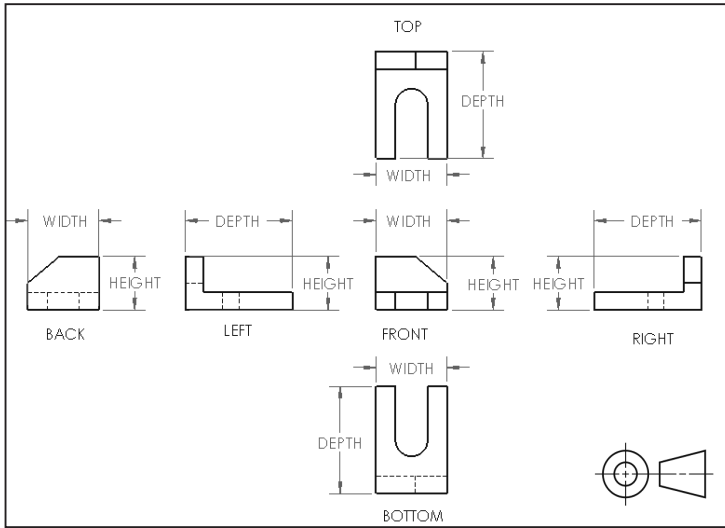

Below are the desired outcomes and usage competencies based on the completion of Chapter 2.

Desired Outcomes:	Usage Competencies:
<ul style="list-style-type: none"> Understand Isometric Projection and 2D sketching. 	<ul style="list-style-type: none"> Identify the three main projection divisions in freehand engineering sketches and drawings: <ul style="list-style-type: none"> Axonometric, Oblique and Perspective
<ul style="list-style-type: none"> Knowledge of additional Projection views and arrangement of drawing views. 	<ul style="list-style-type: none"> Create one and two view drawings.
<ul style="list-style-type: none"> Comprehend the history and evolution of CAD and the development of SOLIDWORKS. Recognize Boolean operations and feature based modeling. 	<ul style="list-style-type: none"> Identify the development of historic CAD systems and SOLIDWORKS features, parameters and design intent of a sketch, part, assembly and drawing. Apply the Boolean operation: Union, Difference and Intersection.

Notes:



Chapter 2 - Isometric Projection and Multi View Drawings

Chapter Overview

Chapter 2 provides a general introduction into Isometric Projection and Sketching along with Additional Projections and arrangement of views. It also covers advanced drawing views and an introduction from manual drafting to CAD.

On the completion of this chapter, you will be able to:



- Know and explain Isometric Projection.
- Create an Isometric sketch.
- Identify the three main projection divisions in freehand engineering sketches and drawings:
 - Axonometric
 - Oblique
 - Perspective
- Understand the history and evolution of CAD.
- Recognize the following Boolean operations: Union, Difference and Intersection.
- Explain design intent of a sketch, part, assembly and drawing.

Isometric Projections

There are three main projection divisions commonly used in freehand engineering sketches and detailed engineering drawings; they are 1.) Axonometric, with its divisions in Isometric, Dimetric and Trimetric, 2.) Oblique and 3.) Perspective. Let's review the three main divisions.

Axonometric is a type of parallel projection, more specifically a type of Orthographic projection, used to create a pictorial drawing of an object, where the object is rotated along one or more of its axes relative to the plane of projection.

There are three main types of axonometric projection: *Isometric*, *Dimetric* and *Trimetric* projection depending on the exact angle at which the view deviates from the Orthogonal.

 To display Isometric, Dimetric, or Trimetric of a 3D SOLIDWORKS model, select the drop-down arrow from the View Orientation  icon in the Heads-up view toolbar.

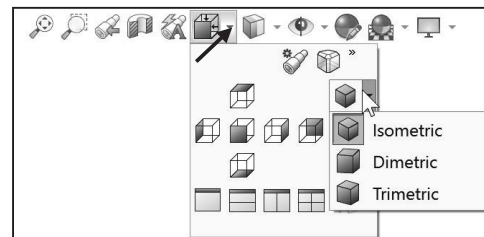

Axonometric drawings often appear distorted because they ignore the foreshortening effects of perspective (foreshortening means the way things appear to get smaller in both height and depth as they recede into the distance). Typically, Axonometric drawings use vertical lines for those lines representing height and sloping parallel edges for all other sides.

- *Isometric Projection.* Isometric projection is a method of visually representing three-dimensional objects in two dimensions, in which the three coordinate axes appear equally foreshortened and the angles between them are 120°.



The term "Isometric" comes from the Greek for "equal measure" reflecting that the scale along each axis of the projection is the same (this is not true of some other forms of graphical projection).

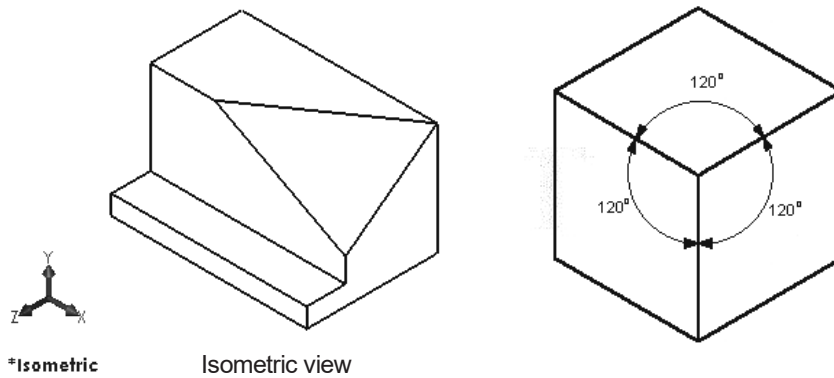

- *Dimetric Projection.* A Dimetric projection is created using 3 axes, but only two of the three axes have equal angles. The smaller these angles are, the less we see of the top surface. The angle is usually around 105°.

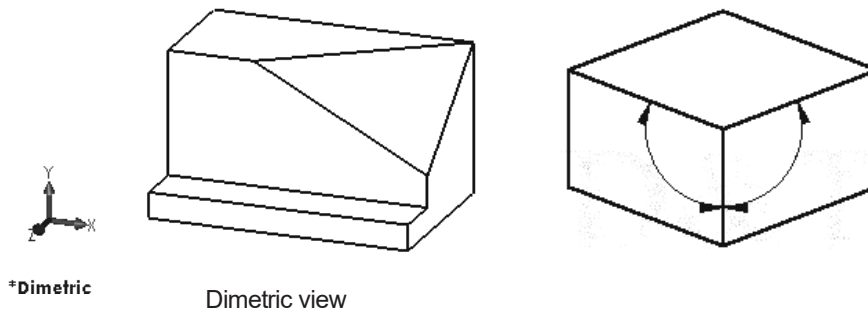

- *Trimetric Projection.* A Trimetric projection is created using 3 axes where each of the angles between them is different (there are no equal angles). The scale along each of the three axes and the angles among them are determined separately as dictated by the angle of viewing. Approximations in trimetric drawings are common.

Isometric Sketching

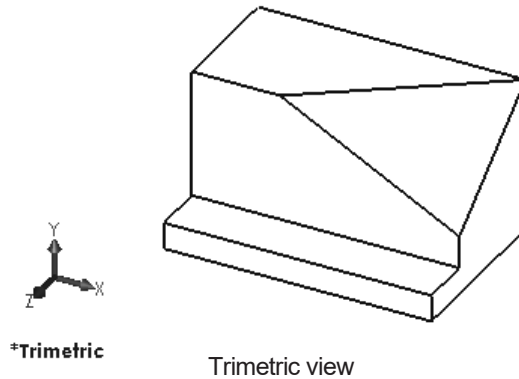

Isometric sketches provide a 3D dimensional pictorial representation of an object. Isometric sketches help in the visualization of an object.

The surface features or the axes of the object are drawn around three axes from a horizontal line: a vertical axis, a 30° axis to the right, and a 30° axis to the left. All three axes intersect at a single point on the horizontal line.

All horizontal lines in an Isometric sketch are always drawn at 30° and parallel to each other and are either to the left or to the right of the vertical.

For this reason, all shapes in an Isometric sketch are not true shapes; they are distorted shapes.

All vertical lines in an Isometric sketch are always drawn vertically, and they are always parallel to each other as illustrated in the following example.

Example 1:

Exercise: Draw an Isometric sketch of a cube.

1. Draw a light horizontal axis (construction line) as illustrated on graph paper. Draw a light vertical axis. Draw a light 30° axis to the right. Draw a light 30° axis to the left.
2. Measure the length along the left 30° axis, make a mark and draw a light vertical line.
3. Measure the height along the vertical axis, make a mark and draw a light 30° line to the left to intersect the vertical line drawn in step 2.
4. Measure the length along the right 30° axis, make a mark and draw a light vertical line.
5. From the height along the vertical axis, make a mark and draw a light 30° line to the right to intersect the vertical line drawn in step 4.
6. Draw a light 30° line to the right and a light 30° line to the left to complete the cube. Once the sketch is complete, darken the shape.



In an Isometric drawing, the object is viewed at an angle, which makes circles appear as ellipses.



Isometric Rule #1: Measurement can only be made on or parallel to the isometric axis.

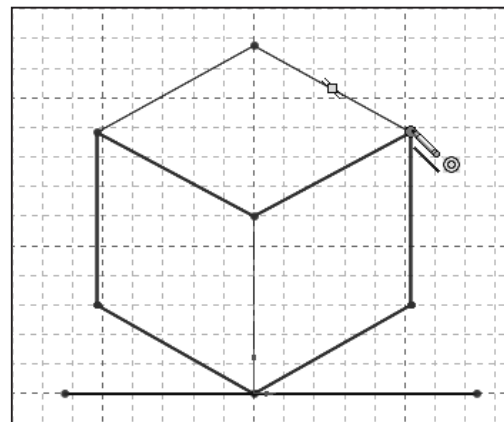
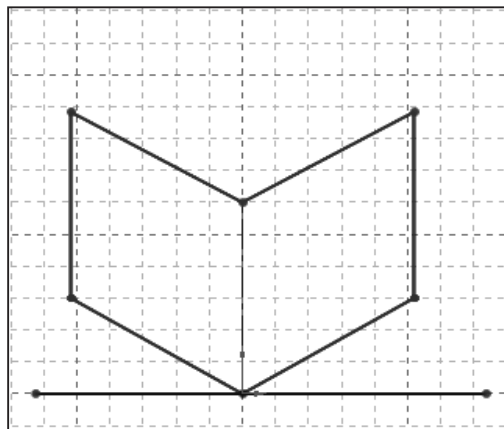
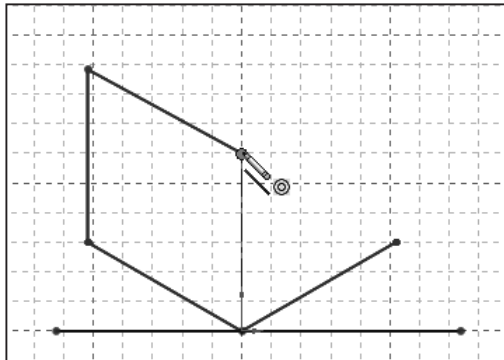
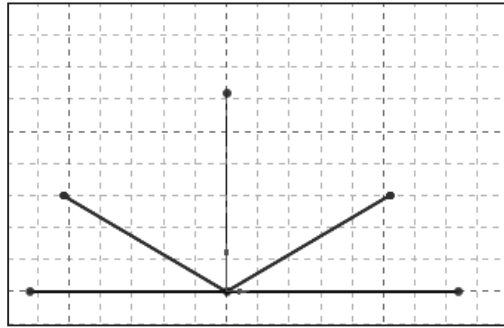

Circles Drawn in Axonometric View

A circle drawn on a sloping surface in Axonometric projection will be drawn as an ellipse. An ellipse is a circle turned through an angle. The examples displayed on the last page were box shapes without any curved surfaces. In order to draw a curved surface, we need to know how to draw an ellipse.

If you draw a circle and rotate it slowly, it will become an ellipse. As it is turned through 90° - it will eventually become a straight line. Rotate it 90° again, and it will eventually be back to a circle.

Example 1:

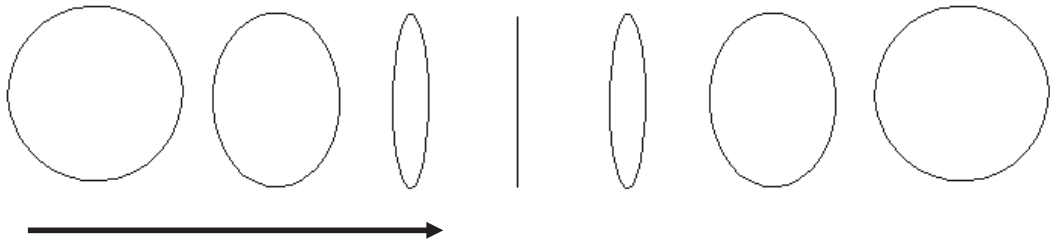

An ellipse has a major axis and a minor axis. The major axis is the axis about which the ellipse is being turned. The minor axis becomes smaller as the angle through which the ellipse is turned approaches 90°.

You can draw a cylinder using the technique shown below. The ellipses can either be sketched freehand or drawn using an ellipse template.

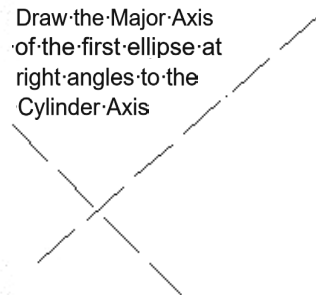
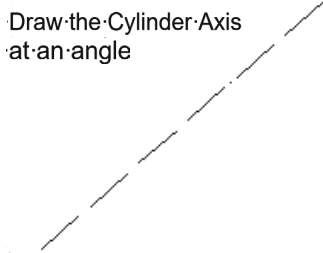
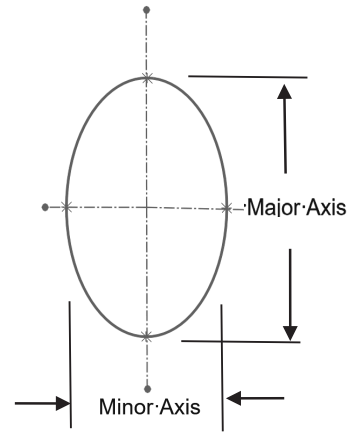

Draw the first ellipse

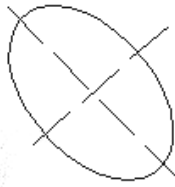

Measure the length of the Cylinder and draw the second major axis

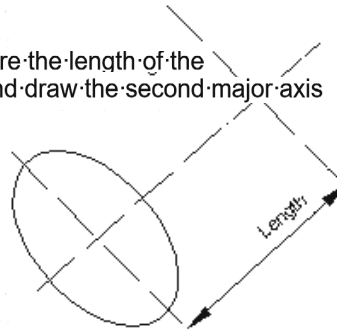

Draw the second ellipse

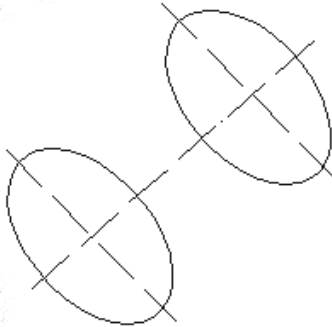

Complete the Cylinder

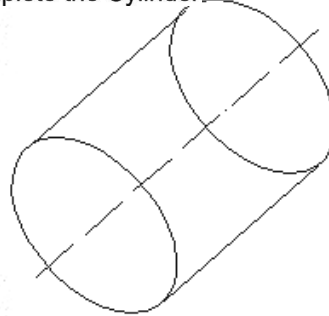

Line in the Completed Cylinder

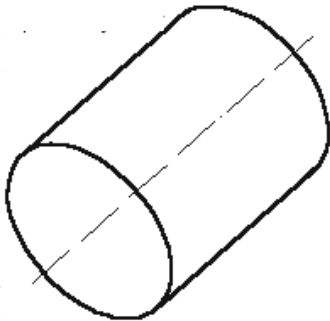

Isometric Rule #2: When drawing ellipses on normal isometric planes, the minor axis of the ellipse is perpendicular to the plane containing the ellipse. The minor axis is perpendicular to the corresponding normal isometric plane.

Additional Projections

Oblique Projection: In Oblique projections, the front view is drawn true size, and the receding surfaces are drawn on an angle to give it a pictorial appearance. This form of projection has the advantage of showing one face (the front face) of the object without distortion.

Generally, the face with the greatest detail faces the front.

There are two types of Oblique projection used in engineering design.

- *Cavalier:* In Cavalier Oblique drawings, all lines (including receding lines) are created to their true length or scale (1:1).
- *Cabinet:* In Cabinet Oblique drawings, the receding lines are shortened by one-half their true length or scale to compensate for distortion and to approximate more closely what the human eye would see. It is for this reason that Cabinet Oblique drawings are the most used form of Oblique drawings.

In Oblique drawings, the three axes of projection are vertical, horizontal, and receding. The front view (vertical & horizontal axis) is parallel to the frontal plane and the other two faces are oblique (receding).

The direction of projection can be top-left, top-right, bottom-left, or bottom-right. The receding axis is typically drawn at 60°, 45° or 30°.

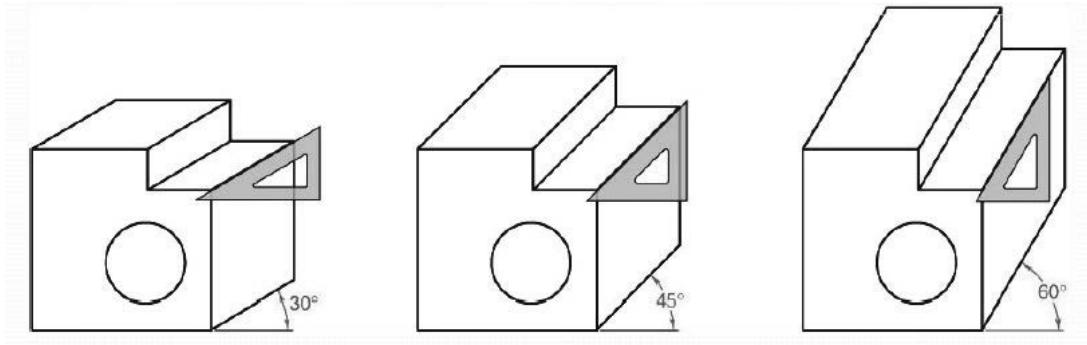
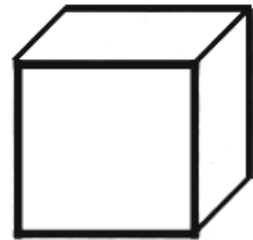
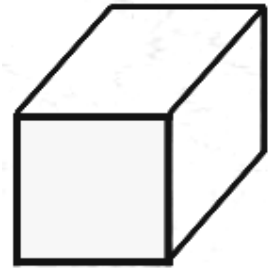

In the oblique pictorials coordinate system, only one axis is at an angle. The most commonly used angle is 45°.

 **Isometric Rule #1:** A measurement can only be made on or parallel to the isometric axis. Therefore, you cannot measure an isometric inclined or oblique line in an isometric drawing because they are not parallel to an isometric axis.

Example: Drawing cylinders in Oblique projection is quite simple if the stages outlined below are followed. In comparison with other ways of drawing cylinders (for example, perspective and isometric) using Oblique projection is relatively easy.

Step One: Draw vertical and horizontal centerlines to indicate the center of a circle, then use a compass to draw the circle itself.

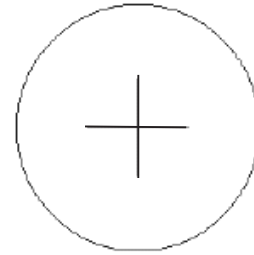

Step Two: Draw a 45° line to match the length on the cylinder. At the end of this line, draw vertical and horizontal centerlines.

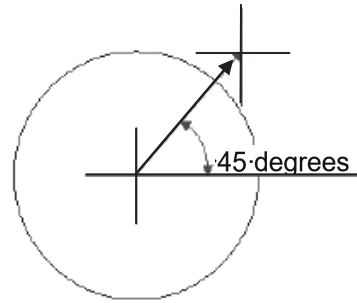

Remember the general rule for Oblique is to half all distances projected backwards. If the cylinder is 100mm in length the distance back must be drawn to 50mm.

Step Three: Draw the second circle with a compass as illustrated.

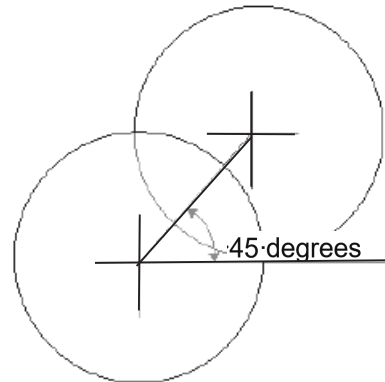
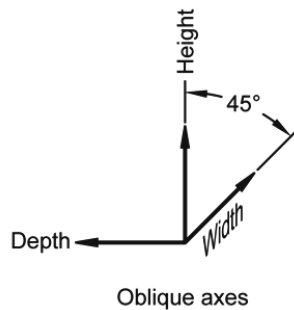

Step Four: Draw two 45° lines to join the front and back circles.

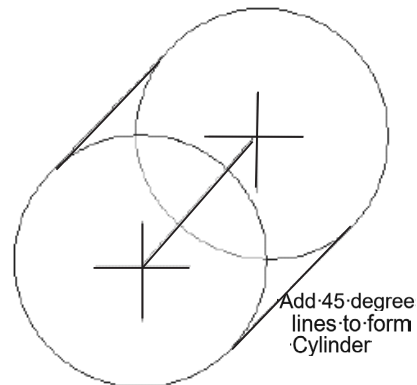

Step Five: Go over the outline of the cylinder with a fine pen or sharp pencil. Add shading if required.

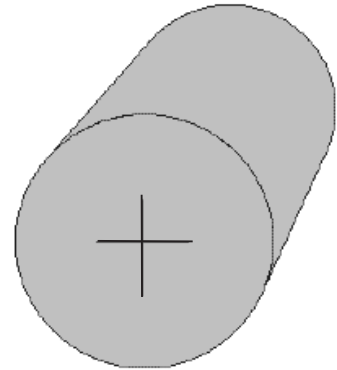

Perspective Projection: If you look along a straight road, the parallel sides of the road appear to meet at a point in the distance. This point is called the vanishing point and has been used to add realism. Suppose you want to draw a road that vanishes into the distance. The rays from the points a given distance from the eye along the lines of the road are projected to the eye. The angle formed by the rays decreases with increasing distance from the eye.



 To display a Perspective view in SOLIDWORKS of a 3D model, click View, Display, Perspective from the Main toolbar.

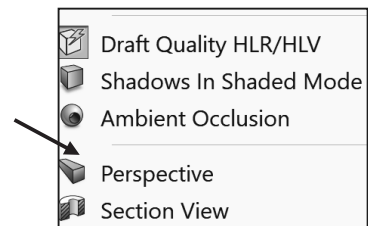

A perspective drawing typically aims to reproduce how humans see the world: objects that are farther away seem smaller, etc. Depending on the type of perspective (1-pt, 2-pt, 3-pt), vanishing points are established in the drawing towards which lines recede, mimicking the effect of objects diminishing in size with distance from the viewer.

One vanishing point is typically used for roads, railroad tracks, or buildings viewed so that the front is directly facing the viewer as illustrated above.

Any objects that are made up of lines either directly parallel with the viewer's line of sight or directly perpendicular (the railroad slats) can be represented with one-point perspective.



The selection of the locations of the vanishing points, which is the first step in creating a perspective sketch, will affect the looks of the resulting images.

Two-point perspective can be used to draw the same objects as one-point perspective, rotated: looking at the corner of a house, or looking at two forked roads shrink into the distance, for example.

One point represents one set of parallel lines, the other point represents the other. Looking at a house from the corner, one wall would recede towards one vanishing point; the other wall would recede towards the opposite vanishing point as illustrated.

Two Point
Perspective

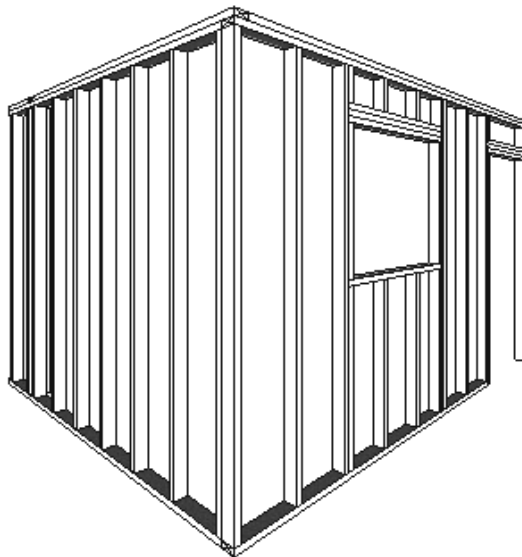

Three-point perspective is usually used for buildings seen from above (or below). In addition to the two vanishing points from before, one for each wall, there is now one for how those walls recede into the ground. This third vanishing point will be below the ground. Looking up at a tall building is another common example of the third vanishing point. This time the third vanishing point is high in space.

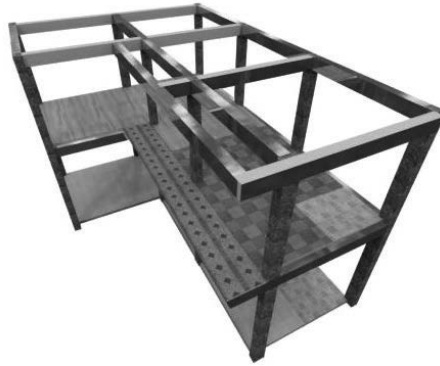

💡 One-point, two-point and three-point perspectives appear to embody different forms of calculated perspective. Despite conventional perspective drawing wisdom, perspective basically just means "position" or "viewpoint" of the viewer relative to the object.

Arrangement of Views

The main purpose of an engineering drawing is to provide the manufacturer with sufficient information needed to build, inspect or assemble the part or assembly according to the specifications of the designer. Since the selection and arrangement of views depends on the complexity of a part, only those views that are needed should be drawn.

The average part drawing which includes the Front view, Top view and Right view are known as a three-view drawing. However, the designation of the views is not as important as the fact that the combination of views must give all the details of construction in a clear, correct and concise way.

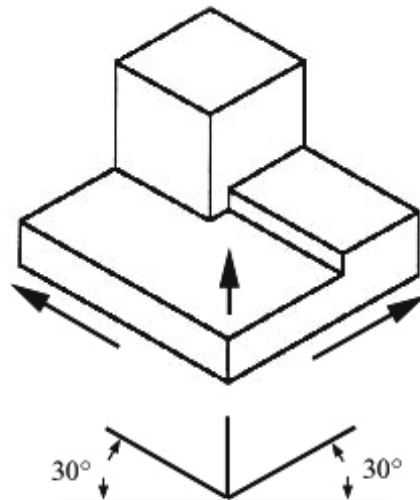

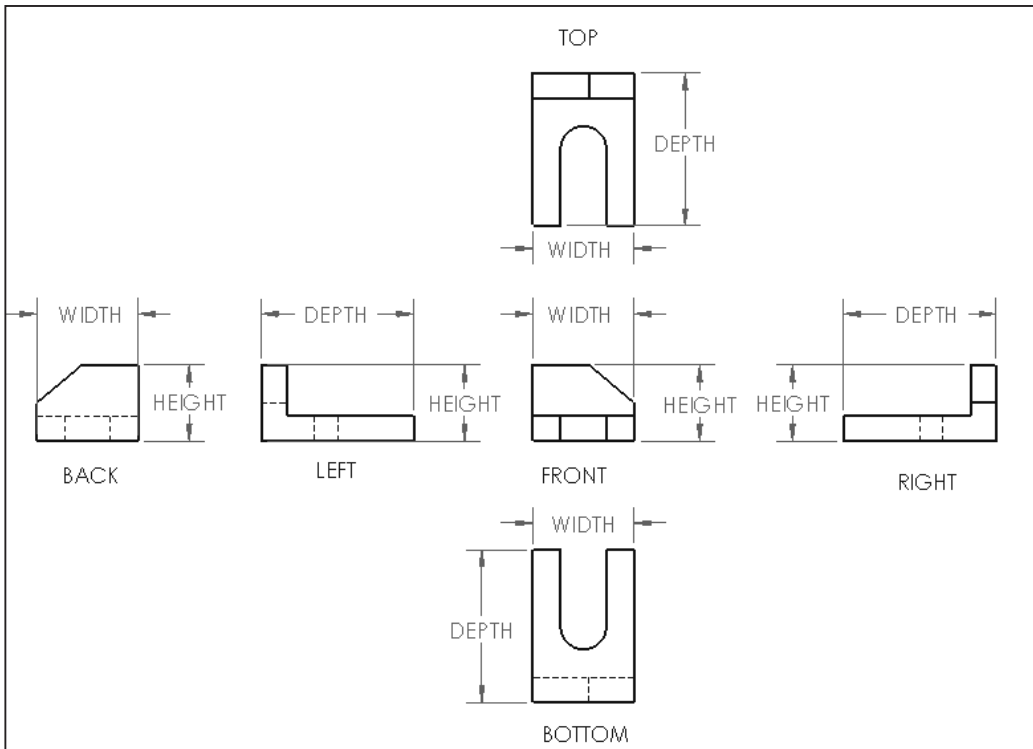

Third “3rd” Angle Projection is displayed and used in the book.

In SOLIDWORKS, when you create a new part or assembly, the three default Planes (Front, Right and Top) are aligned with specific views.

The Plane you select for the Base sketch determines the orientation of the part, the drawing views and the assembly.

Two-view drawing

Simple symmetrical flat objects and cylindrical parts such as sleeves, shafts, rods and studs most of the time only require two views to provide the full details of construction and or inspection.

Always use annotations when needed.

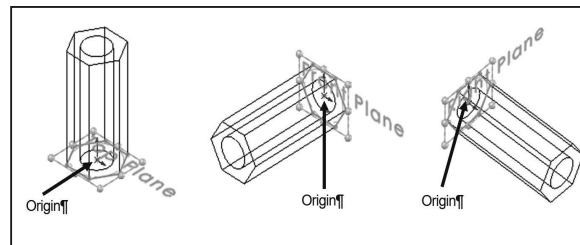
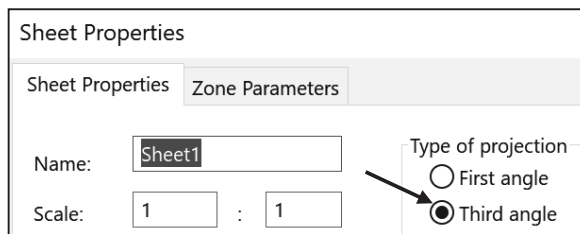

In the Front view below, a centerline runs through the axis of the part as a horizontal centerline.

The second view (Right view) of the two-view drawing contains a center mark at the center of the cylinders.

The selection of views for a two-view drawing rests largely with the designer/engineer.

Example 1:

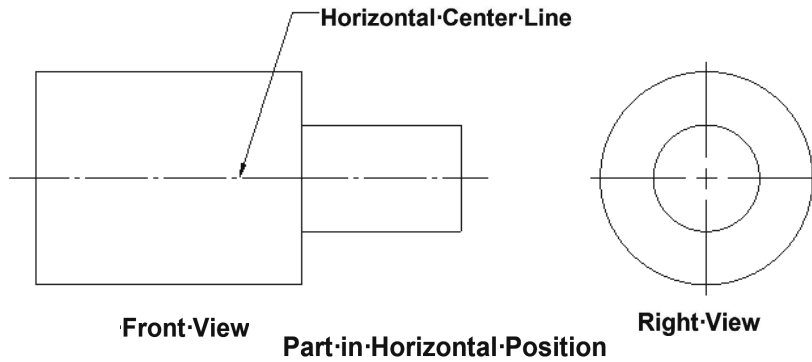

Example 2:

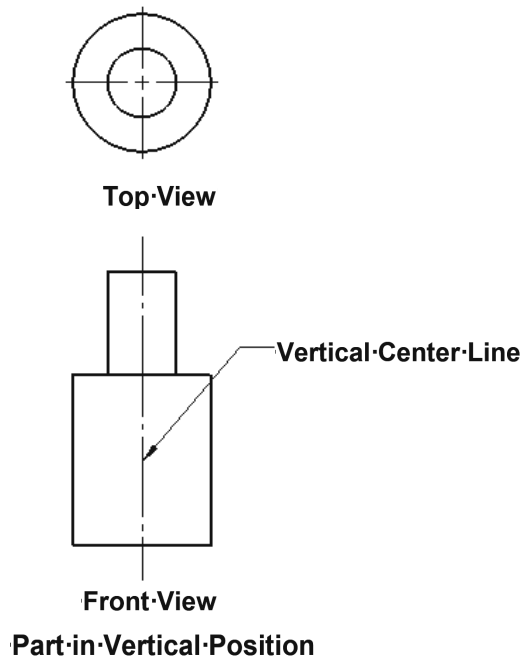

One-view drawing

Parts that are uniform in shape often require only one view to describe them adequately. This is particularly true of cylindrical objects where a one-view drawing saves time and simplifies the drawing.

When a one-view drawing of a cylindrical part is used, the dimension for the diameter (according to ANSI standards) must be preceded by the symbol \varnothing , as illustrated.

Example 1:

The one-view drawing is also used extensively for flat (Sheet metal) parts. With the addition of notes to supplement the dimensions on the view, the one view furnishes all the necessary information for accurately describing the part.

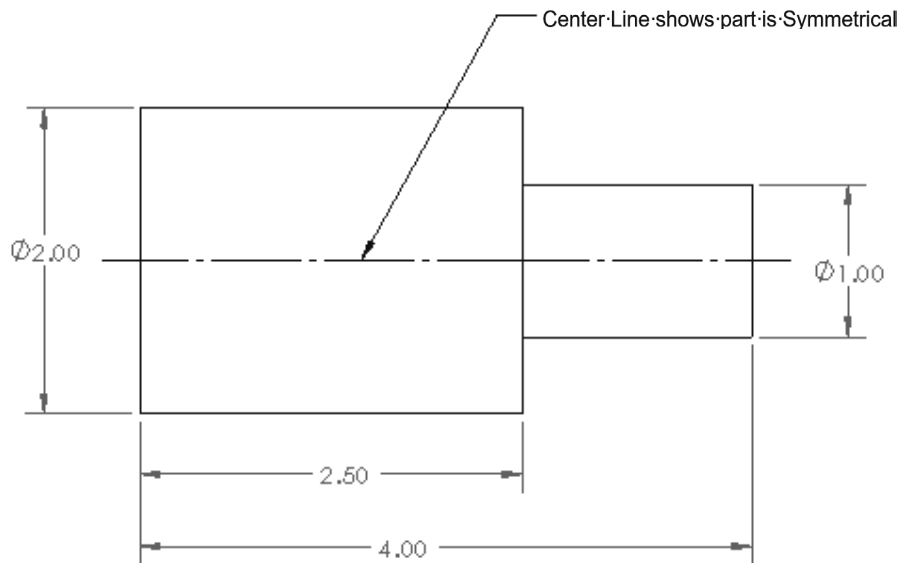

In the first illustration below, you have two views: Front view and Top view. In the section illustration below, you replace the Top view with a Note: MATERIAL THICKNESS .125 INCH. Utilize Smart Notes when using a 3D software package. The note is linked to the dimension/s of the model.



Third Angle Projection type symbol is illustrated.

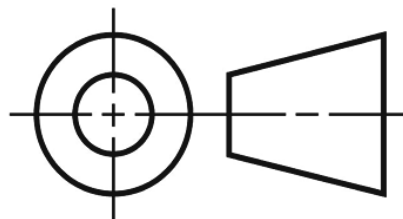

Example 1: No Note Annotation.

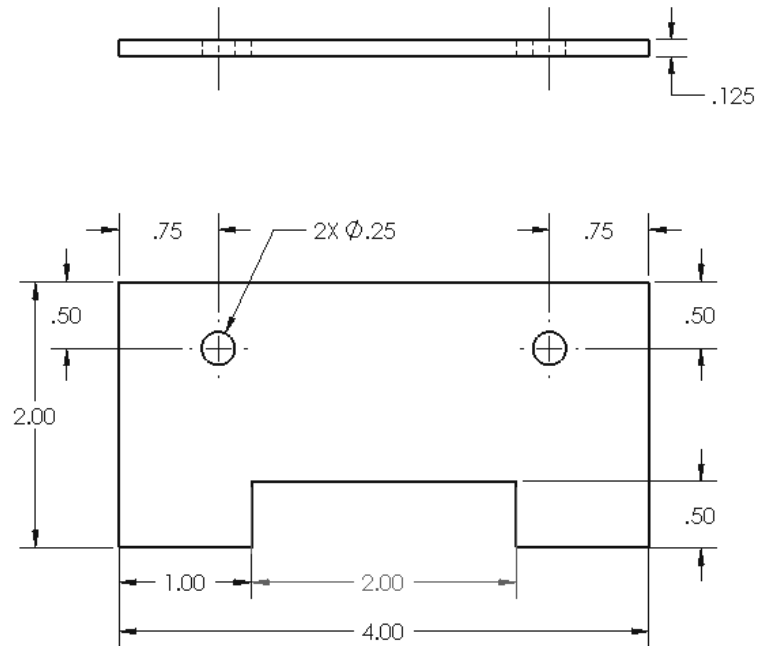

Example 2: Note Annotation to replace the Top View.

MATERIAL THICKNESS .125 INCH

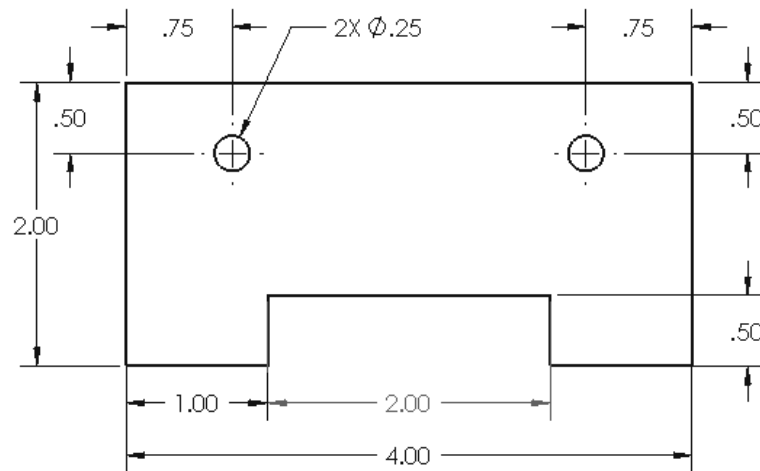

Example 3: Note Fastener Annotation.



A multi-view drawing should have the minimum number of views necessary to describe an object completely. The most descriptive views are those that reveal the most information about the features, with the fewest features hidden from view.

When you create a new part or assembly, the three default Planes (Front, Right and Top) are aligned with specific views.

The Plane you select for the Base sketch determines the orientation of the part, the orientation of the Front drawing view and the orientation of the first component in the assembly.

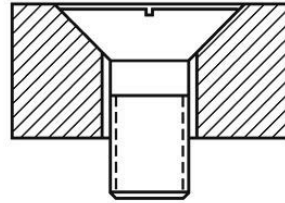
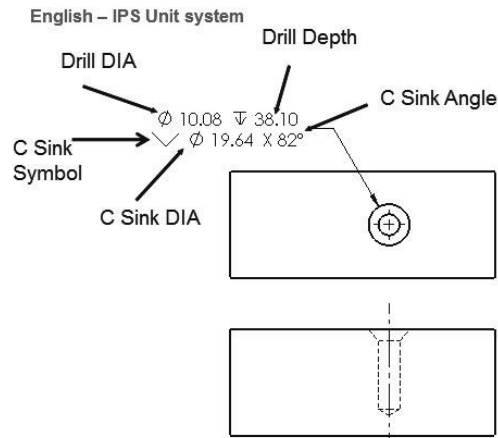

Note: SOLIDWORKS provides the ability to insert Head clearance for the Counter Sink hole.

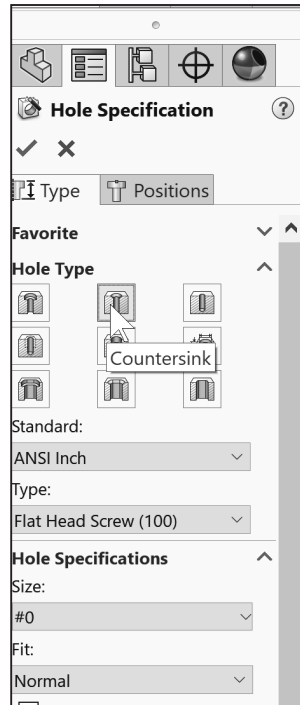
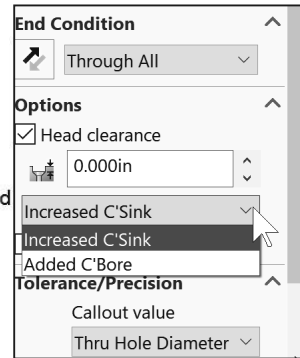

Exercises:

Exercise 1:

Draw freehand the Isometric view of the illustrated model on graph paper. Approximate the size of the model.

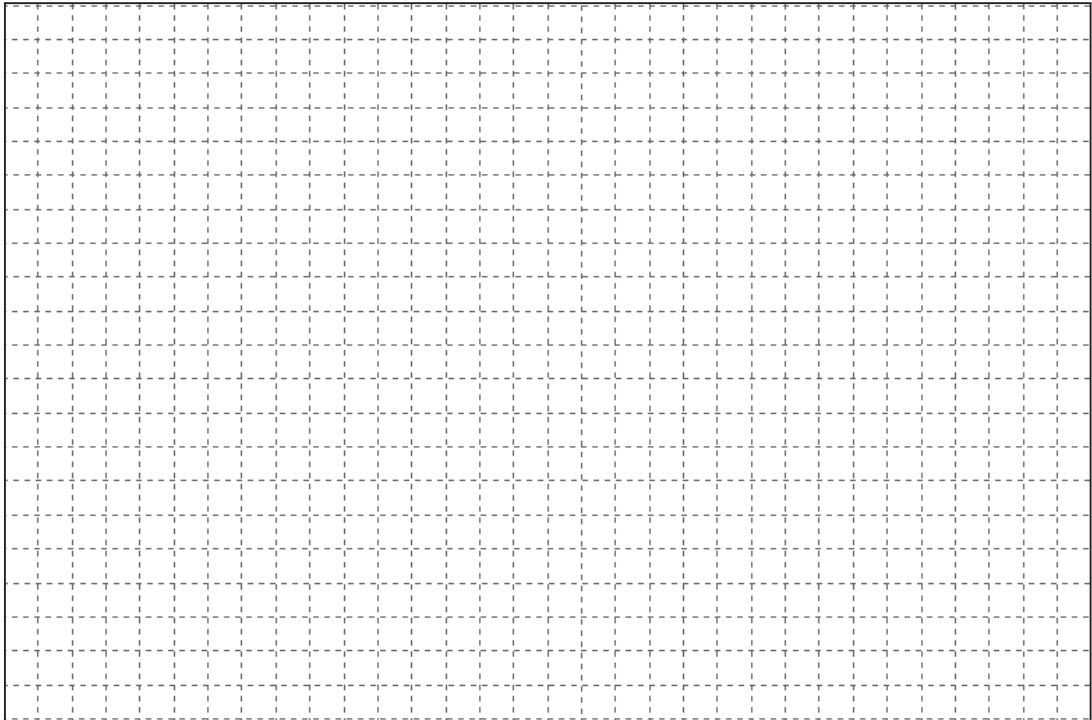
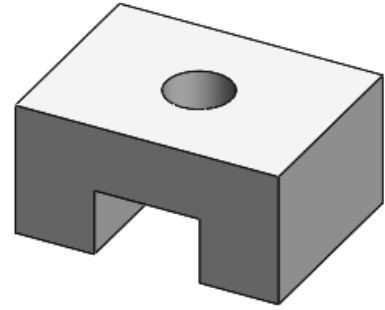

Exercise 2:

Name each view and insert the Width, Height and Depth name. No dimensions are required in this exercise.

Note: Centerlines are not displayed. Third Angle Projection is used.

Sheet Properties	
Sheet Properties	Zone Parameters
Name:	<input type="text" value="Sheet1"/>
Scale:	<input type="text" value="1"/> : <input type="text" value="2"/>
Type of projection	<input type="radio"/> First angle <input checked="" type="radio"/> Third angle

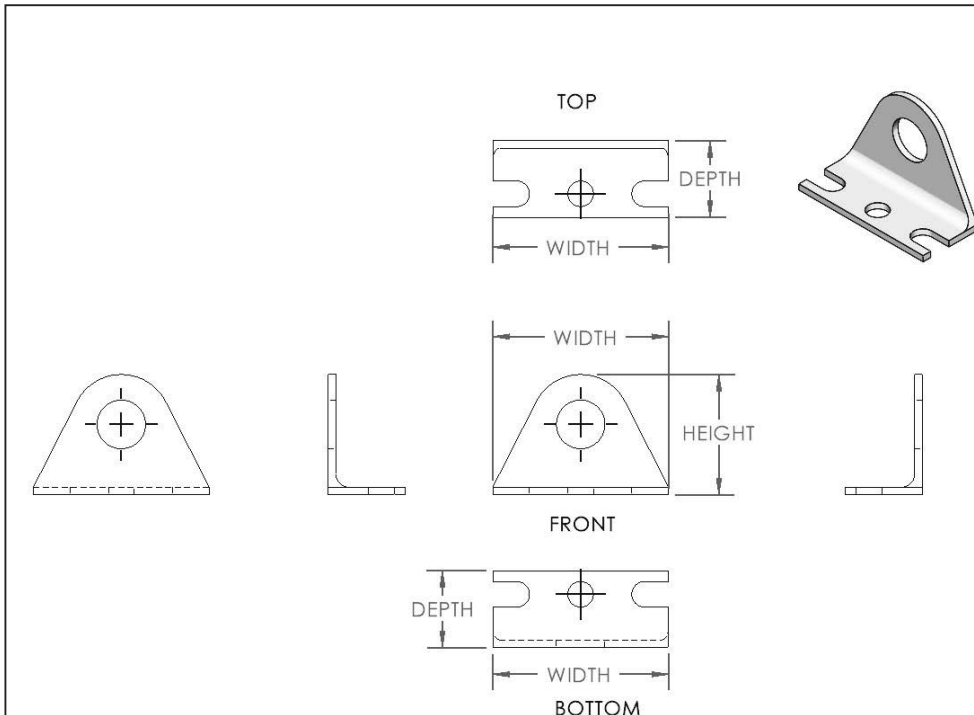

Drawing Views - Advanced

The standard views used in an orthographic projection are Front view, Top view, Right view and Isometric view. Non-standard orthographic drawing views are used when the six principal views do not fully describe the part for manufacturing or inspection. Below are a few non-standard orthographic drawing views.

Section view

Section views are used to clarify the interior of a part that can't clearly be seen by hidden lines in a view.

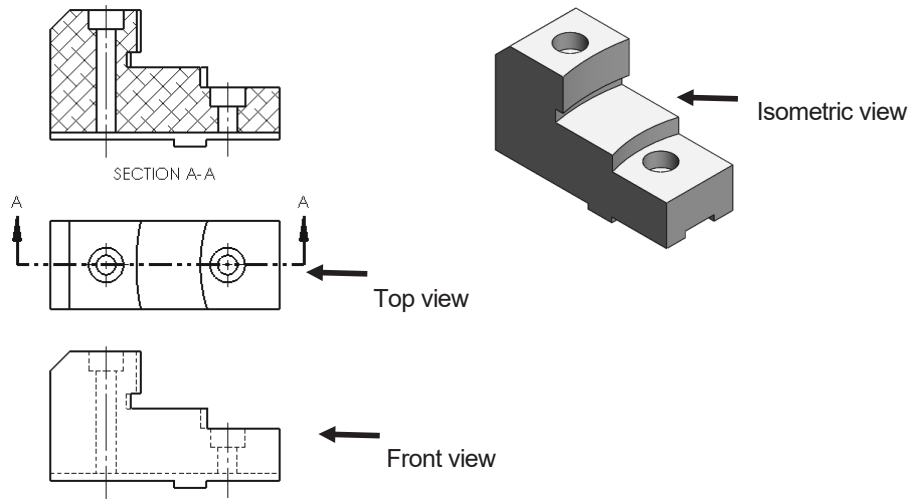

Think of an **imaginary** cutting (Plane) through the object and removing a portion. Imaginary is the key word.

A Section view is a child of the parent view. The Cutting Plane arrows used to create a Section view indicate the direction of sight. Section lines in the Section view are bounded by visible lines.

Section lines in the Section view can serve the purpose of identifying the kind of material the part is made from. Below are a few examples:

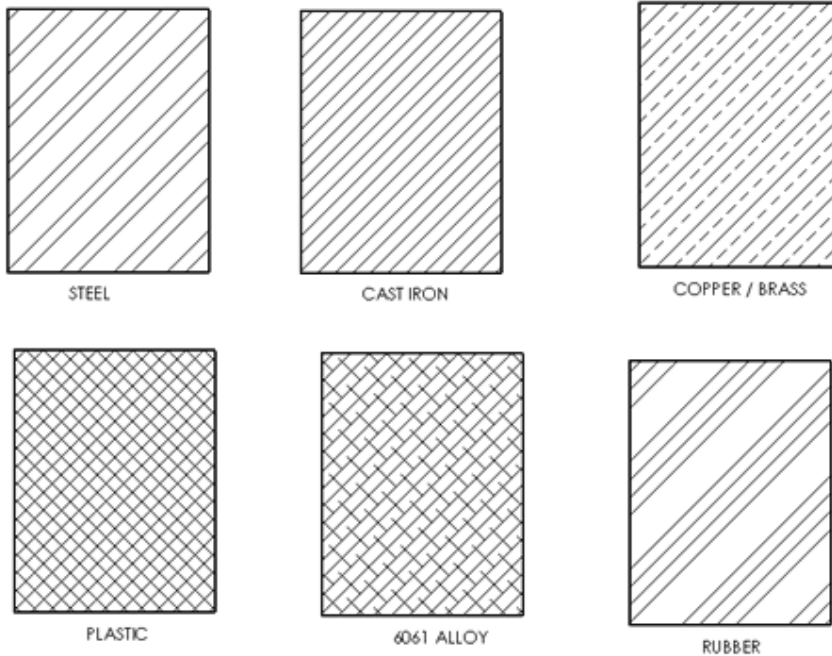

💡 To avoid a false impression of thickness, ribs are normally not sectioned.

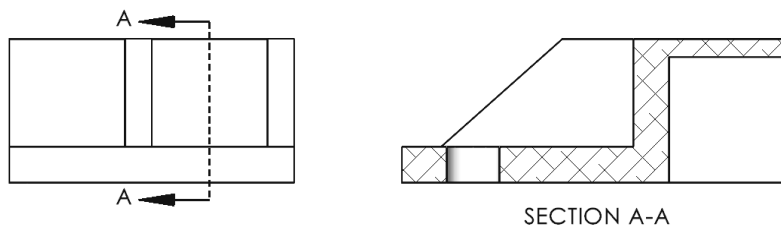

Detail View

The Detail view provides the ability to add a portion of a view, usually at an enlarged scale. A Detail view is a child of the parent view. Create a detail view in a drawing to display or highlight a portion of a view.

A Detail view may be of an Orthographic view, a non-planar (isometric) view, a Section view, a Crop view, an Exploded assembly view or another detail view.

Example 1:

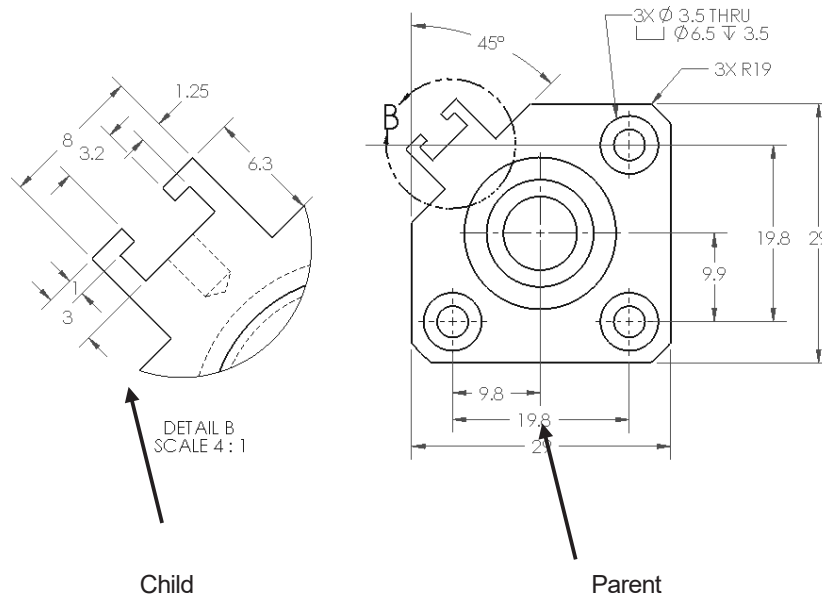

If the Detail view has a different scale than the sheet, the scale needs to be supplied as an annotation as illustrated.

Example 2:

Below is a Detail view of a Section view. The Detail view is a child view of the parent view (Detail view). The Section view cannot exist without the Detail view.

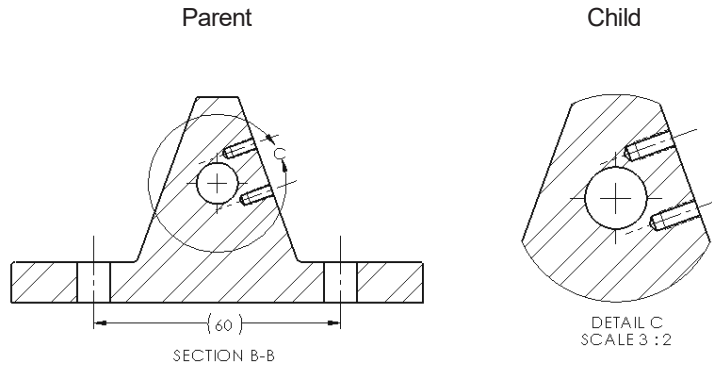

Broken out View

A Broken-out section is part of an existing drawing view, not a separate view. Material is removed to a specified depth to expose inner details. Hidden lines are displayed in the non-sectioned area of a broken section. View two examples of a Broken out View below.

Example 1:

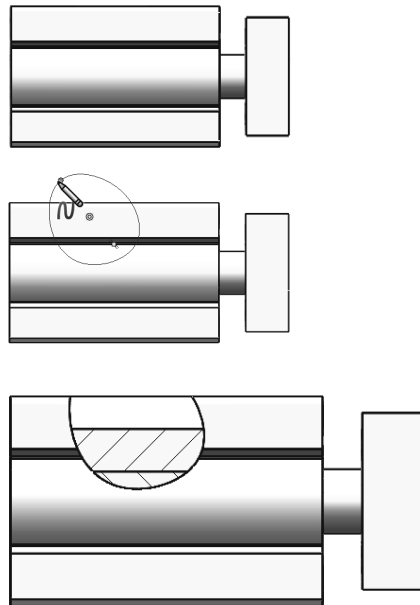

Example 2:

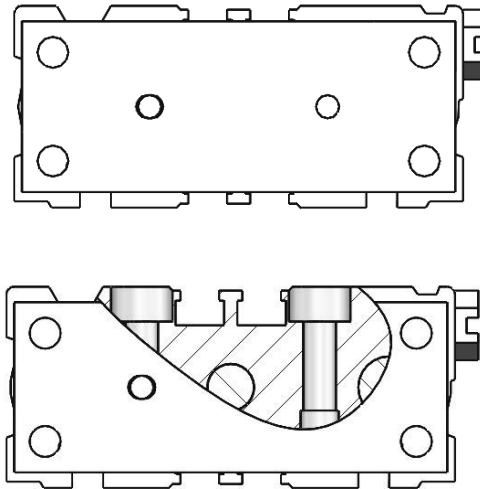

Break or Broken View

A Break view is part of an existing drawing view, not a separate view. A Break view provides the ability to add a break line to a selected view. Create a Broken view to display the drawing view in a larger scale on a smaller drawing sheet size. Reference dimensions and model dimensions associated with the broken area reflect the actual model values.

Example 1:

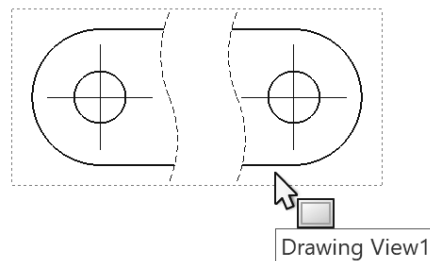
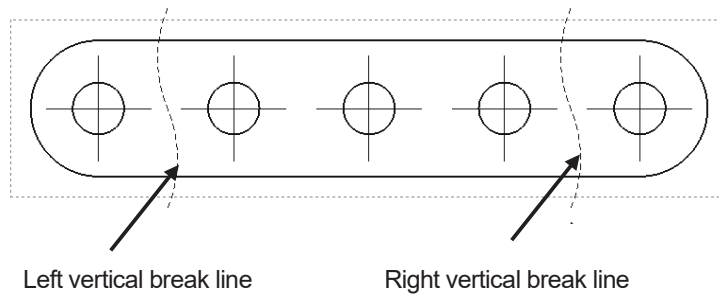

Example 2:

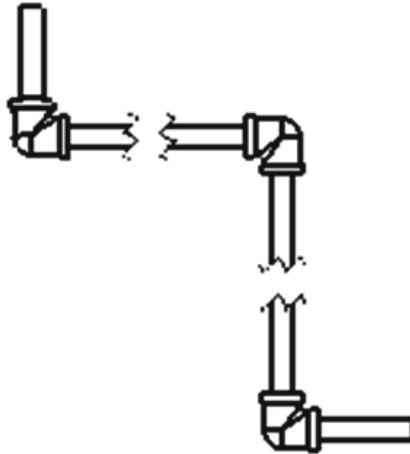

Crop View

A Crop view is a Child of the Parent view. A Crop view provides the ability to crop an existing drawing view. You cannot create a Crop view on a Detail view, a view from which a Detail view has been created or an Exploded view.

Create a Crop view to save time. Example: instead of creating a Section view and then a Detail view, then hiding the unnecessary Section view, create a Crop view to crop the Section view directly.

Example 1:

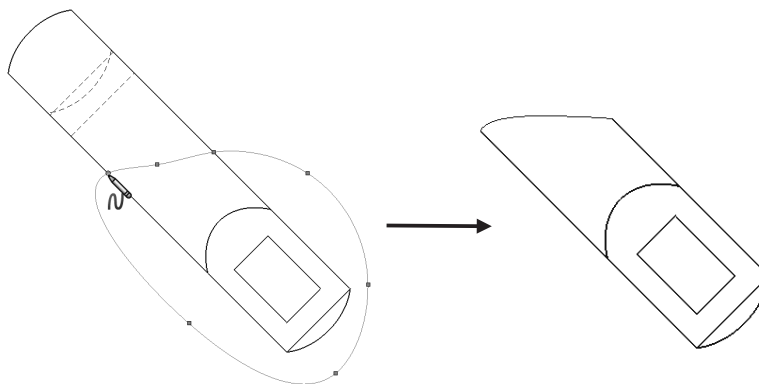

Auxiliary View

An Auxiliary view is a Child of the Parent view. An Auxiliary view provides the ability to display a plane parallel to an angled plane with true dimensions.

A primary Auxiliary view is hinged to one of the six principle orthographic views.

Example 1:

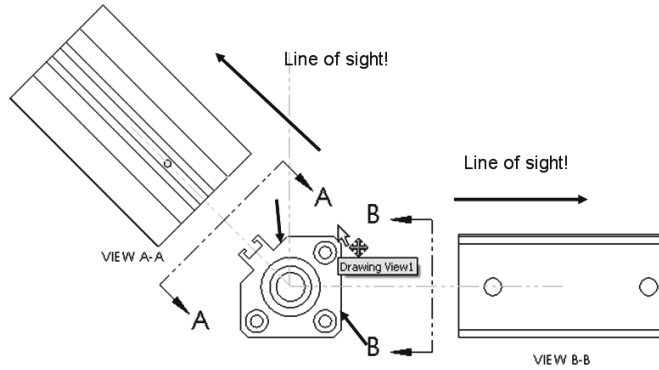

Exercises:

Exercise 1:

Label all of the name views below. Note: Third Angle projection.

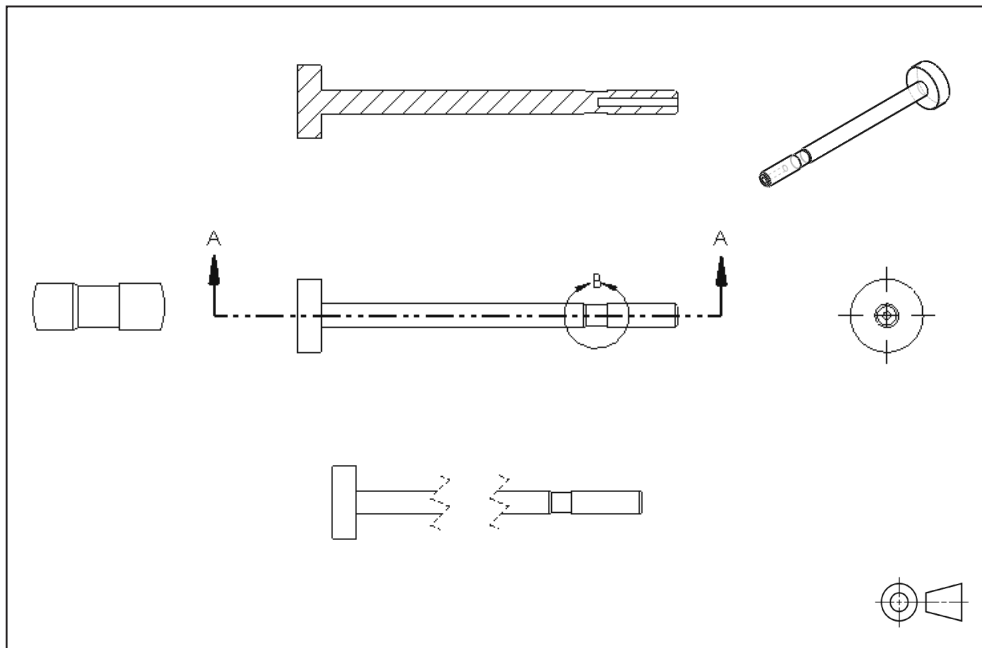

History of Computer Aided Design (CAD)

In 1963, Ivan Sutherland of MIT developed “Sketchpad,” a graphical communication system, where with a light pen, Sutherland was able to select and modify geometry on a Cathode Ray System (CRT) and input values through a keypad. Geometric relationships were made between lines and arc, and geometry could be moved and copied.

With aerospace and automotive technologies becoming more complex and IBM mainframe computers commercially available in the late 1960s and early 1970s, companies such as MacDonal-Douglas, Lockheed, General Motors, and Ford were utilizing their own internal CAD systems to design, manipulate and store models and drawings. Digital Equipment Corporation (DEC) and Prime Computer introduced computer hardware platforms that made CAD data storage and development more affordable. Ford’s Product Design Graphics System (PDGS) developed into one of the largest integrated CAD systems in the 1980s.

By 1980, Cambridge Interact Systems (UK) introduced CIS Medusa, that was bought and distributed by Prime Computer and ran on a proprietary workstation and used Prime mini computers for data storage. Mid size companies, such as AMP and Carrier, were now using CAD in their engineering departments. Other CAD software companies also introduced new technology. Computervision utilized both proprietary hardware and SUN workstations and became a leader in 2D drafting technology.

But in the early 80s, 3D CAD used Boolean algorithms for solid geometry that were a challenge for engineers to manipulate. Other major CAD players were Integraph, GE Calma, SDRC, and IBM (Dassault Systèmes). Dassault Systèmes, with its roots in the aerospace industry, expanded development in CAD surface modeling software technology with Boeing and Ford.

In the late 80s, Parametric Technology Corporation (PTC) introduced CAD software to the market with the ability to manipulate a 3D solid model, running on a UNIX workstation platform. By changing dimensions directly on the 3D model, driven by dimensions and parameters, the model updated and was termed parametric.

By the early 90s, the Personal Computer (PC) was becoming incorporated in the engineer’s daily activities for writing reports and generating spreadsheets. In 1993, SOLIDWORKS founder Jon Hirschtick recruited a team of engineers to build a company and develop an affordable, 3D CAD software application that was easy to use and ran on an intuitive Windows platform, without expensive hardware and software to operate.

In 1995, SOLIDWORKS was introduced to the market as the first 3D feature based, parametric solid modeler running on a PC. The company’s rapidly growing customer base and continuous product innovation quickly established it as a strong competitor in the CAD market. The market noticed, and global product lifecycle technology giant Dassault Systèmes S.A. acquired SOLIDWORKS for \$310 million in stock in June of 1997.



Boolean operations

To understand the difference between parametric solid modeling and Boolean based solid modeling you will first review Boolean operations. In the 1980s, one of the key advancements in CAD was the development of the Constructive Solid Geometry (CSG) method. Constructive Solid Geometry describes the solid model as combinations of basic three-dimensional shapes or better known as primitives. Primitives are typically simple shapes: cuboids, cylinders, prisms, pyramids, spheres and cones.

Two primitive solid objects can be combined into one using a procedure known as the Boolean operations. There are three basic Boolean operations:

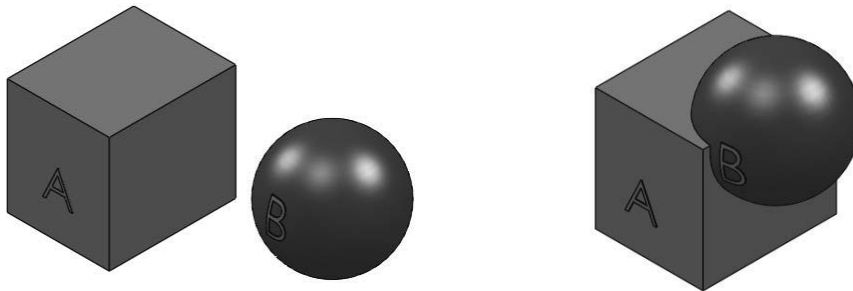
- Boolean Union
- Boolean Difference
- Boolean Intersection

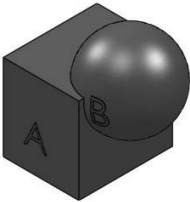
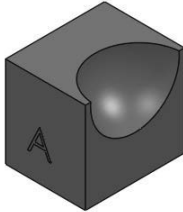

Boolean Operation:	Result:
<p><i>Boolean Union</i> - The merger of two separate objects into one.</p> <p>$A + B$</p>	
<p><i>Boolean Difference</i> - The subtraction of one object from another.</p> <p>$A - B$</p>	
<p><i>Boolean Intersection</i> - The portion common to both objects.</p> <p>$A \cap B$</p>	

Even today, Boolean operations assist the SOLIDWORKS designer in creating a model with more complex geometry by combining two bodies together with a Boolean intersection.

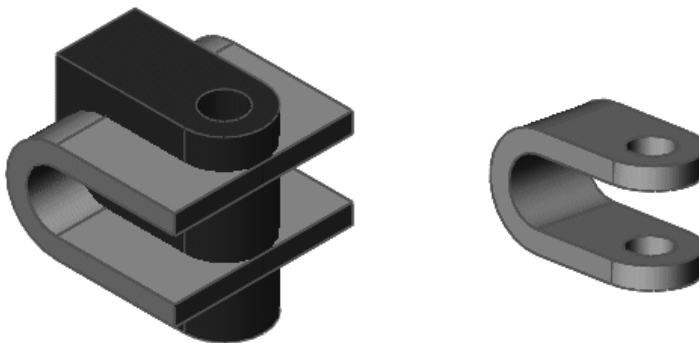

Use the SOLIDWORKS Tutorial to view Multi-body Parts, Boolean model examples.

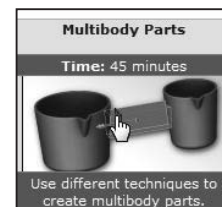

What is SOLIDWORKS?

SOLIDWORKS® is a design tool by Dassault Systèmes. The 3DEXPERIENCE® platform is a technology platform that connects SOLIDWORKS to other design, simulation, intelligent information and collaboration Apps through a web browser.

SOLIDWORKS® is a mechanical design automation software package used to build parts, assemblies and drawings that takes advantage of the familiar Microsoft® Windows graphical user interface.

SOLIDWORKS is an easy to learn design and analysis tool (SOLIDWORKS Simulation, SOLIDWORKS Motion, SOLIDWORKS Flow Simulation, Sustainability, etc.), which makes it possible for designers to quickly sketch 2D and 3D concepts, create 3D parts and assemblies and detail 2D drawings.

The part, assembly and drawing documents are related. Additional information on SOLIDWORKS and its family of products can be obtained at their URL, www.SOLIDWORKS.com.

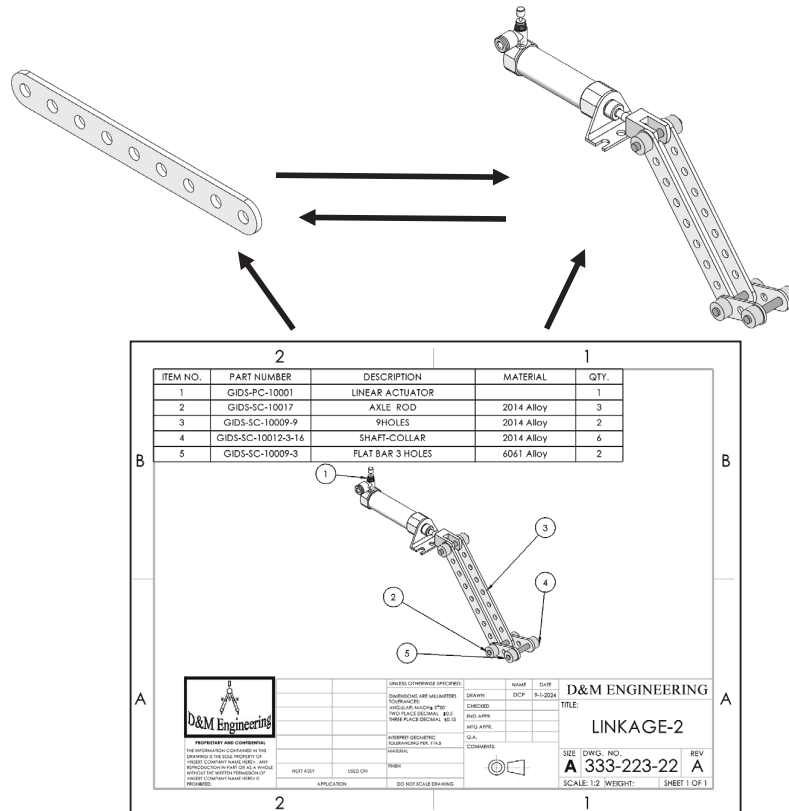

Design Intent

What is design intent? All designs are created for a purpose. Design intent is the intellectual arrangements of features and dimensions of a design. Design intent governs the relationship between sketches in a feature, features in a part and parts in an assembly.

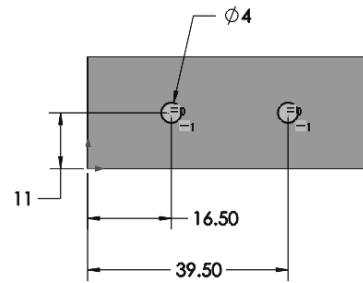

The SOLIDWORKS definition of design intent is the process in which the model is developed to accept future modifications. Models behave differently when design changes occur.

Design for change. Utilize geometry for symmetry, reuse common features, and reuse common parts. Build change into the following areas that you create:

- Sketch
- Feature
- Part
- Assembly
- Drawing



When editing or repairing geometric relations, it is considered best practice to edit the relation vs. deleting it.

Design Intent in a sketch

Build design intent in a sketch as the profile is created. A profile is determined from the Sketch Entities. Example: Rectangle, Circle, Arc, Point, Slot, etc. Apply symmetry into a profile through a sketch centerline, mirror entity and position about the reference planes and Origin.

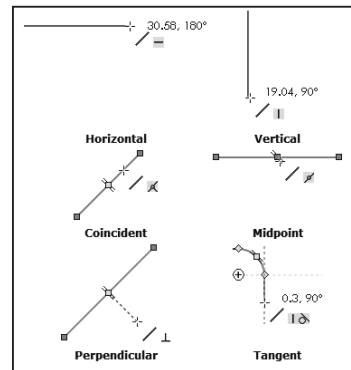

Build design intent as you sketch with automatic Geometric relations. Document the decisions made during the up-front design process. This is very valuable when you modify the design later.

A rectangle (Center Rectangle Sketch tool) contains Horizontal, Vertical and Perpendicular automatic Geometric relations.

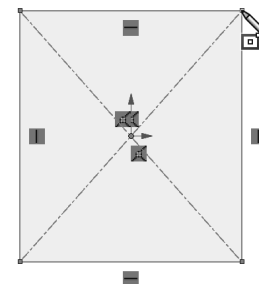
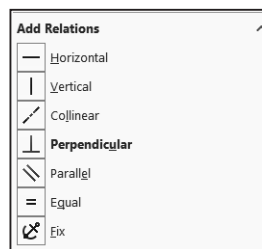

Apply design intent using added Geometric relations if needed. Example: Horizontal, Vertical, Collinear, Perpendicular, Parallel, Equal, etc.

Example A: Apply design intent to create a square profile. Sketch a rectangle. Apply the Center Rectangle Sketch tool. Note: No construction reference centerline or Midpoint relation is required with the Center Rectangle tool. Insert dimensions to fully define the sketch.

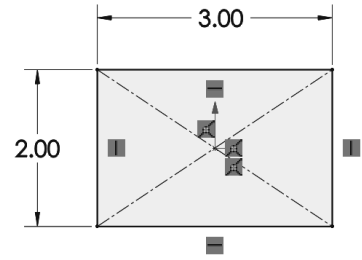

Example B: Develop a rectangular profile. Apply the Corner Rectangle Sketch tool. The bottom horizontal midpoint of the rectangular profile is located at the Origin. Add a Midpoint relation between the horizontal edge of the rectangle and the Origin. Insert two dimensions to fully define the rectangle as illustrated.

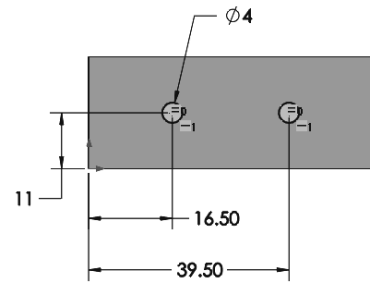

Design intent in a feature

Build design intent into a feature by addressing symmetry, feature selection, and the order of feature creation.

Example A: The Extruded Base feature remains symmetric about the Front Plane. Utilize the Mid Plane End Condition option in Direction 1. Modify the depth, and the feature remains symmetric about the Front Plane.

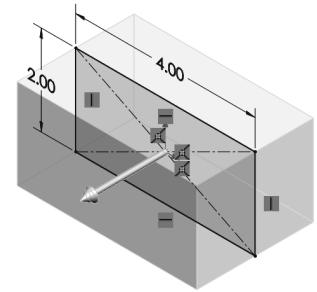

Example B: Create 34 teeth in the model. Do you create each tooth separately using the Extruded Cut feature? No.

Create a single tooth and then apply the Circular Pattern feature. Modify the Circular Pattern from 32 to 24 teeth.

Design intent in a part

Utilize symmetry, feature order and reusing common features to build design intent into a part. Example A: Feature order. Is the entire part symmetric? Feature order affects the part.

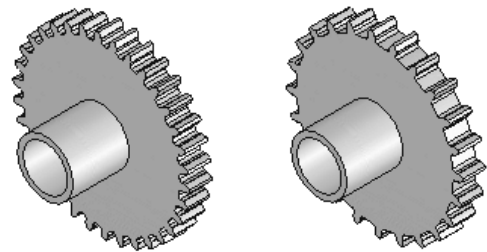

Apply the Shell feature before the Fillet feature and the inside corners remain perpendicular.

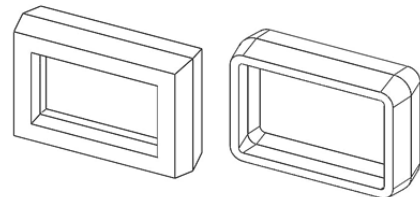

Design intent in an assembly

Utilizing symmetry, reusing common parts and using the Mate relation between parts builds the design intent into an assembly.

Example A: Reuse geometry in an assembly. The assembly contains a linear pattern of holes. Insert one screw into the first hole. Utilize the Component Pattern feature to copy the machine screw to the other holes.

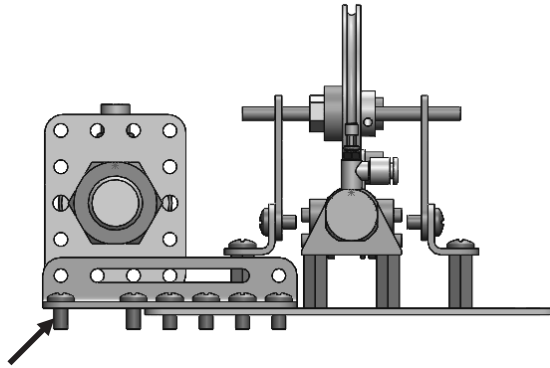

Design intent in a drawing

Utilize dimensions, tolerance and notes in parts and assemblies to build the design intent into a drawing.

Example A: Tolerance and material in the drawing. Insert an outside diameter tolerance $+0.000/-0.002$ into the TUBE part. The tolerance propagates to the drawing.

Define the Custom Property Material in the Part. The Material Custom Property propagates to your drawing.

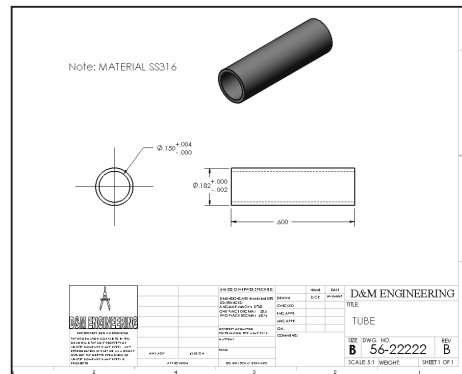

Create a sketch on any of the default planes: Front, Top, Right or a created plane.



Additional information on design process and design intent is available in SOLIDWORKS Help.



The book is designed to expose the new user to many tools, techniques and procedures. It does not always use the most direct tool or process.

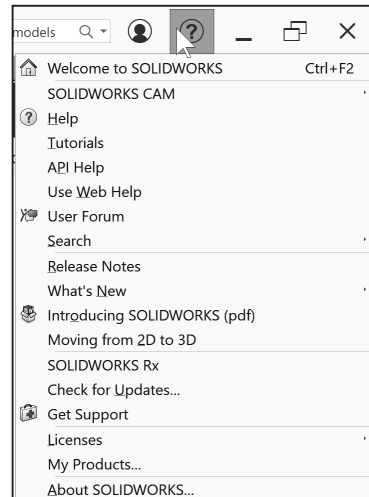

Chapter Summary

Chapter 2 provided a general introduction into isometric projection and sketching along with additional projections and the arrangement of standard views and advanced views. You explored the three main projection divisions in freehand engineering sketches and drawings: Axonometric, Oblique and Perspective.

The chapter also introduced you to the history of CAD and the development of DS SOLIDWORKS Corp. From early Boolean CAD software, you explored Union, Difference, and Intersection operations which are modeling techniques still used today. You were also introduced to the fundamentals of SOLIDWORKS, its feature-based modeling, driven by parameters that incorporate your design intent into a sketch, part, assembly and drawing.



Isometric Rule #1: A measurement can only be made on or parallel to the isometric axis. Therefore, you cannot measure an isometric inclined or oblique line in an isometric drawing because they are not parallel to an isometric axis.



Isometric Rule #2: When drawing ellipses on normal isometric planes, the minor axis of the ellipse is perpendicular to the plane containing the ellipse. The minor axis is perpendicular to the corresponding normal isometric plane.

Questions

1. Name the three main projection divisions commonly used in freehand engineering sketches and detailed engineering drawings: _____ , _____ and _____.
2. Name the projection divisions within Axonometric projection: _____ , _____ , and _____.
3. True or False: In oblique projections the front view is drawn true size, and the receding surfaces are drawn on an angle to give it a pictorial appearance.
4. Name the two types of Oblique projection used in engineering design: _____ , _____.
5. Describe Perspective Projection. Provide an example.
6. True or False: Parts that are uniform in shape often require only one view to describe them adequately.
7. True or False: The designer usually selects as a Front view of the object that view which best describes the general shape of the part. This Front view may have no relationship to the actual front position of the part as it fits into an assembly.
8. True or False: When a one-view drawing of a cylindrical part is used, the dimension for the diameter (according to ANSI standards) must be preceded by the symbol \emptyset .
9. Draw a Third Angle Projection Symbol.
10. Draw a First Angle Projection Symbol.
11. Describe the difference between First and Third Angle Projection.
12. True or False. First Angle Projection is used in the United States.
13. True or False. Section lines can serve the purpose of identifying the kind of material the part is made from.
14. True or False. All dimension lines terminate with an arrowhead on mechanical engineering drawings.
15. True or False. Break lines are applied to represent an imaginary cut in an object, so the interior of the object can be viewed or fitted to the sheet. Provide an example.

Exercises

Exercise 2.1: Hand draw the Isometric view from the illustrated model below.

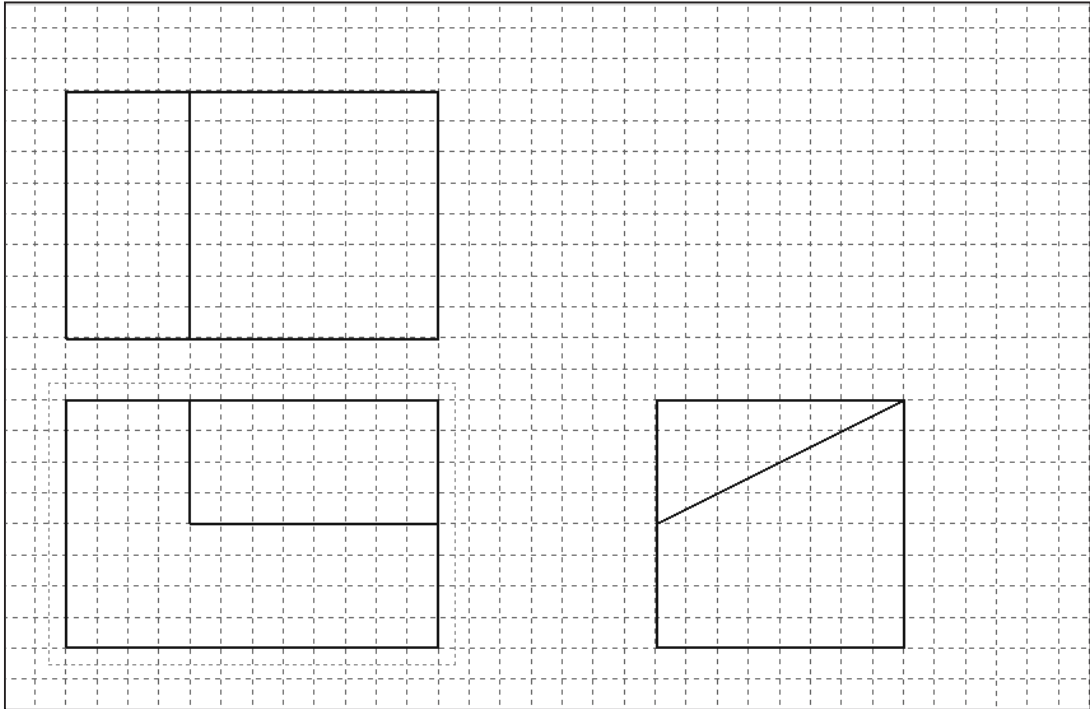

Exercise 2.2: Hand draw the Isometric view for the following models. Approximate the size of the model.

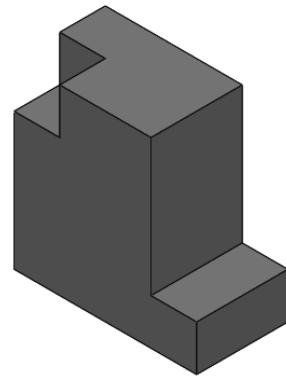
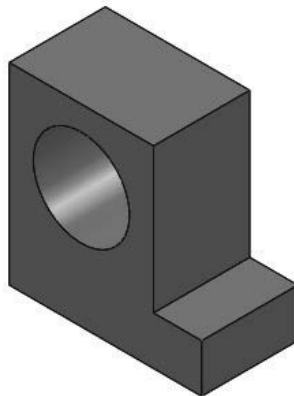

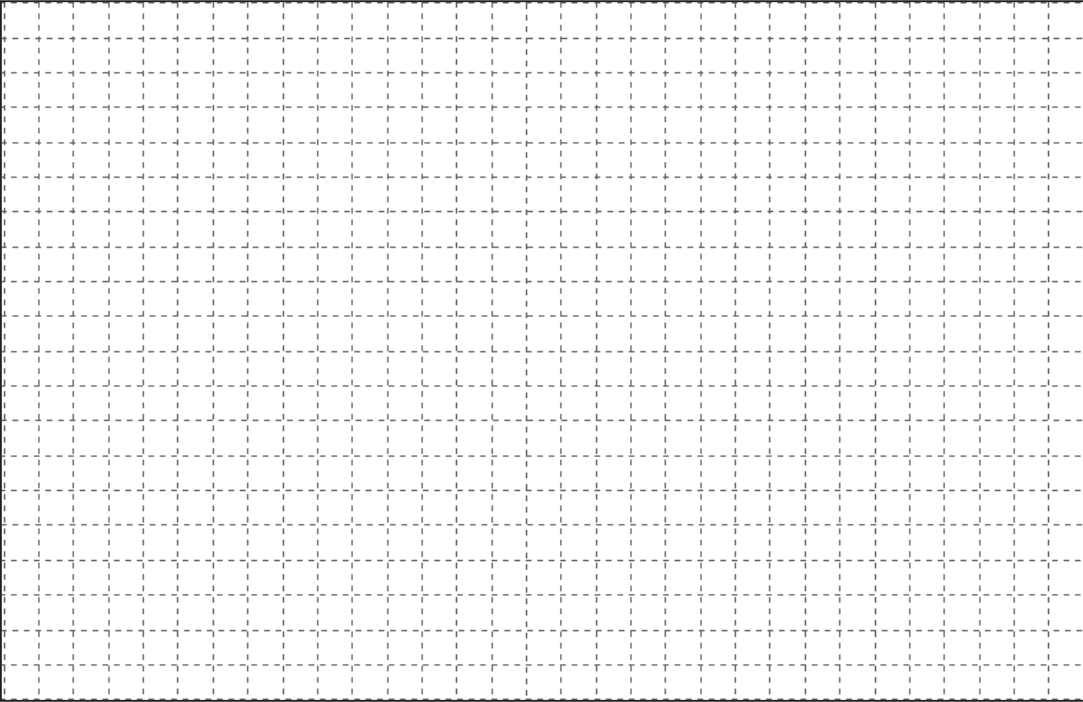
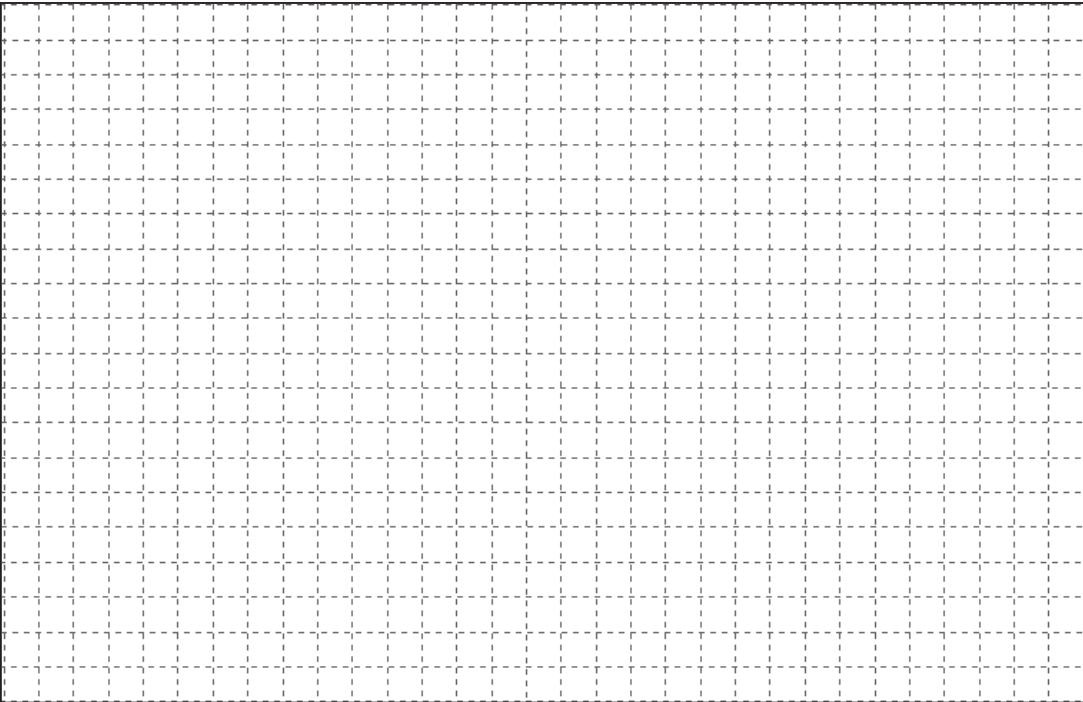

Exercise 2.3: Hand draw the Isometric view for the following models. Approximate the size of the model.

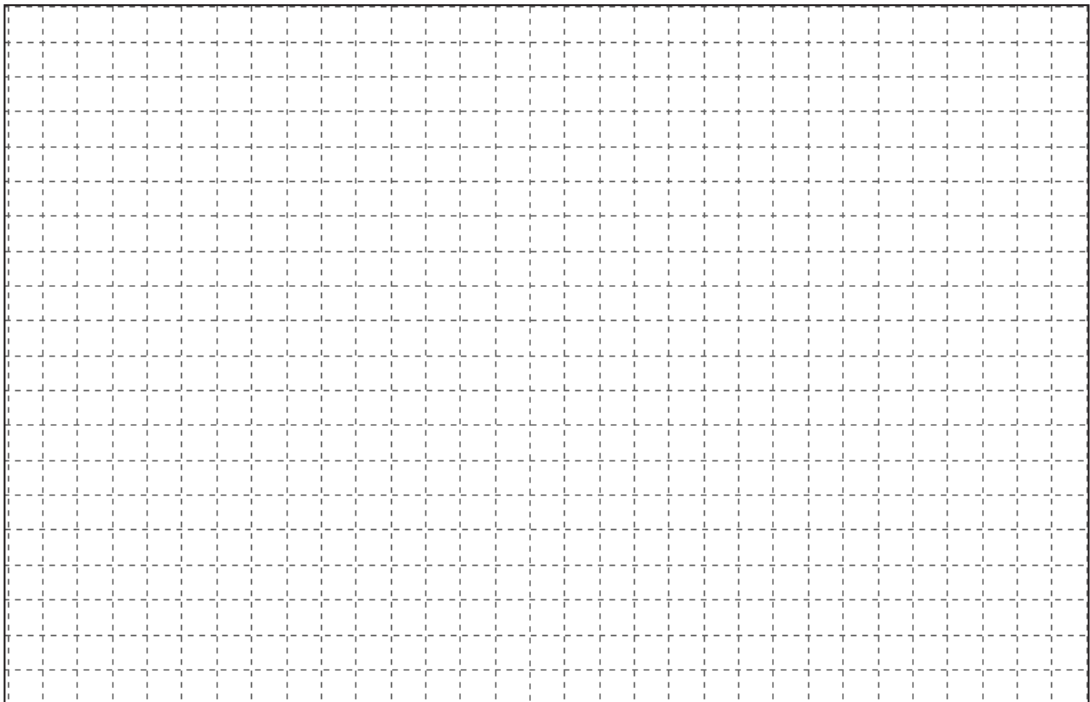
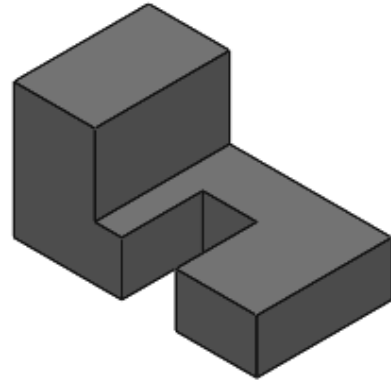
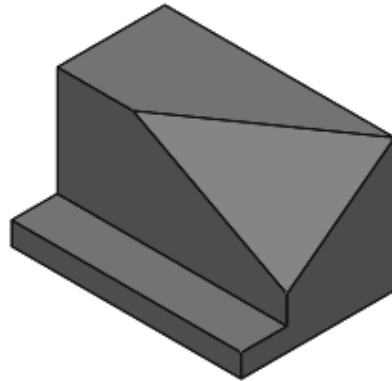

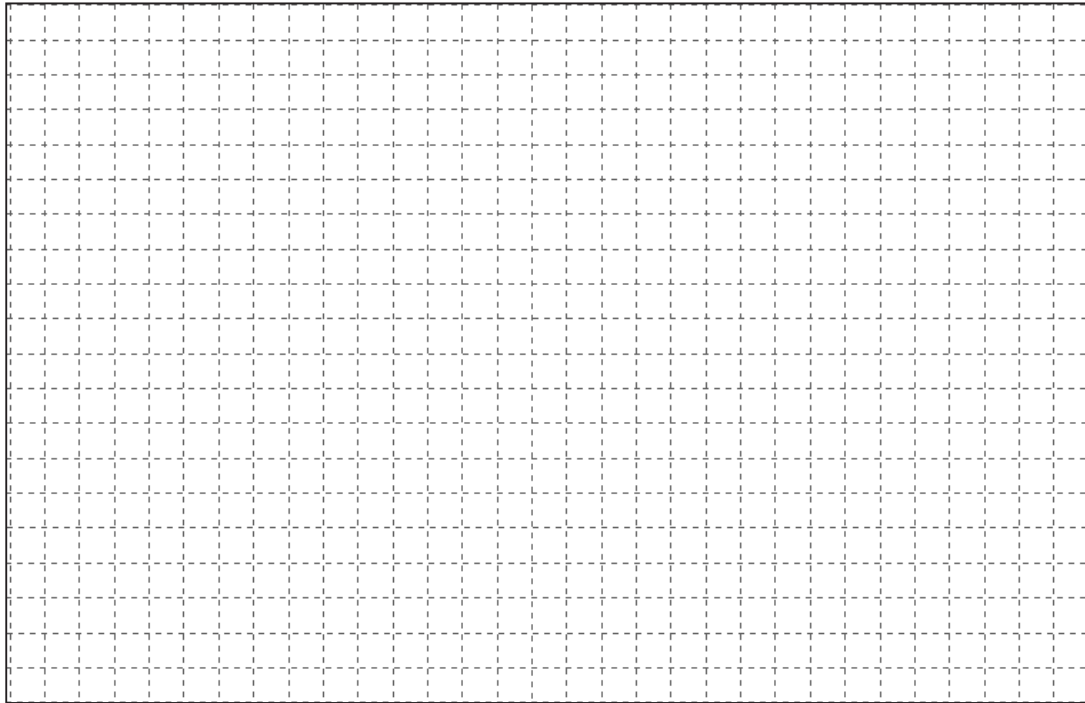

Exercise 2.4: Identify the number of vanishing points for each picture.



1. Number of vanishing points for the first picture. _____

2. Number of vanishing points for the second picture. _____

3. Number of vanishing points for the third picture. _____