

Certified SOLIDWORKS® Professional Advanced Preparation Material

Sheet Metal, Weldments, Surfacing,
Mold Making and Drawing Tools

SOLIDWORKS® 2025



Paul Tran CSWE, CSWI

Visit the following websites to learn more about this book:



[amazon.com](https://www.amazon.com)

[Google books](https://books.google.com)

[BARNES & NOBLE](https://www.barnesandnoble.com)

CHAPTER 1

CSWP – Advanced Drawing Tools

CSWP – Advanced Drawing Tools



Certified SOLIDWORKS Professional Advanced Drawing Tools

The completion of the Certified SOLIDWORKS Professional Advanced Drawing Tools (CSWPA-DT) exam proves that you have successfully demonstrated your ability to use the tools found in the SOLIDWORKS Drawing environment.

Employers can be confident that you understand the tools and functionality to create engineering drawings using SOLIDWORKS.

Note: You must use at least SOLIDWORKS 2010 for this exam. Any use of a previous version will result in the inability to open some of the testing files.

Exam Length: 100 minutes

Minimum Passing grade: 75%

Re-test Policy: There is a minimum 14-day waiting period between every attempt of the CSWPA-DT exam. Also, a CSWPA-DT exam credit must be purchased for each exam attempt.

All candidates receive electronic certificates and a personal listing on the CSWP directory when they pass.

Exam features hands-on challenges in many of these areas of SOLIDWORKS drawing functionality such as:

Basic View Creation, Section Views, Auxiliary Views, Alternate position Views, Broken Out Sections, Lock View/Sheet Focus, Transferring Sketch Entities to/from Views, Bill of materials, and Custom Properties.

CSWP – Advanced Drawing Tools

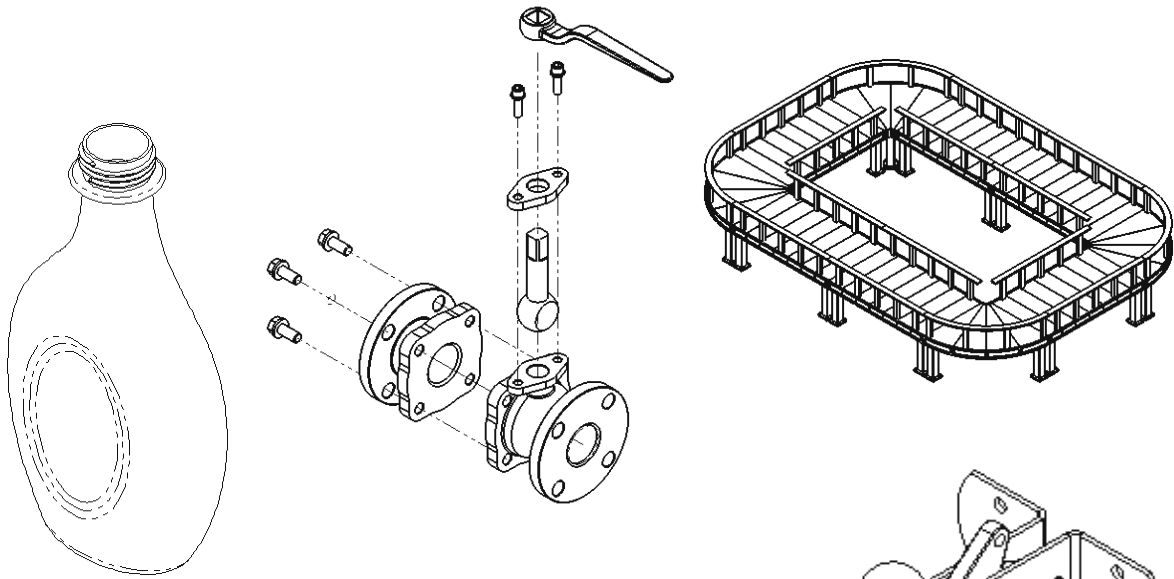

View Orientation Hot Keys:

Ctrl + 1 = Front View
Ctrl + 2 = Back View
Ctrl + 3 = Left View
Ctrl + 4 = Right View
Ctrl + 5 = Top View
Ctrl + 6 = Bottom View
Ctrl + 7 = Isometric View
Ctrl + 8 = Normal To Selection

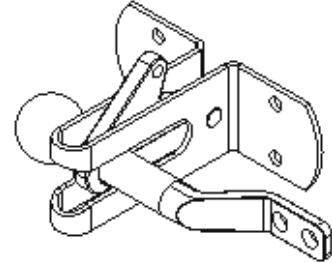
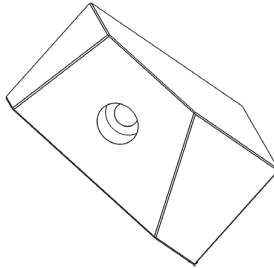

Dimensioning Standards: **ANSI**

Units: **INCHES** – 3 Decimals

Tools Needed:



Part Template



Assembly Template



Drawing Template



View Palette



Section View



Named View



Measure



Auto Balloon



Bill of Materials

CHALLENGE 1

1. Opening a part document: (This challenge focuses on the drawing view creation and calculating the surface perimeters.)

Select **File / Open**.

Browse to the Training Folder and open the part document named: **Plastic Bottle.sldprt**.

2. Transferring to a drawing:

Select **File / Make Drawing From Part** (arrow).

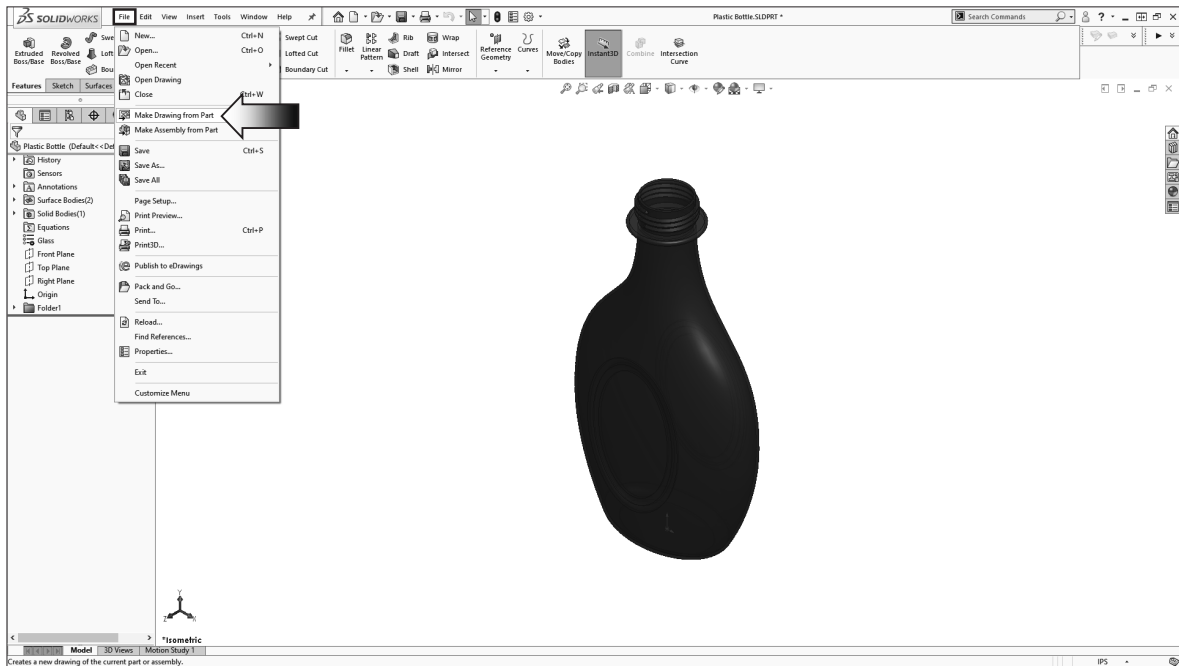

Select the default **Drawing** template.

Click **OK**.

The drawing paper size will be changed in the next step.

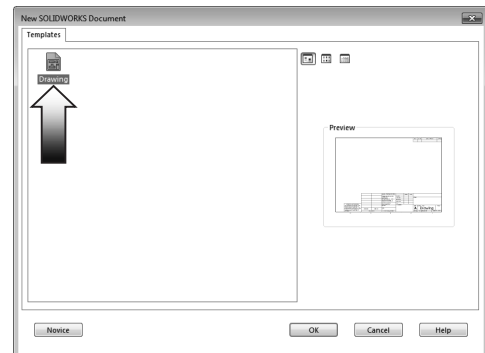

3. Changing the paper size:

Right-click inside the drawing and select **Properties**.

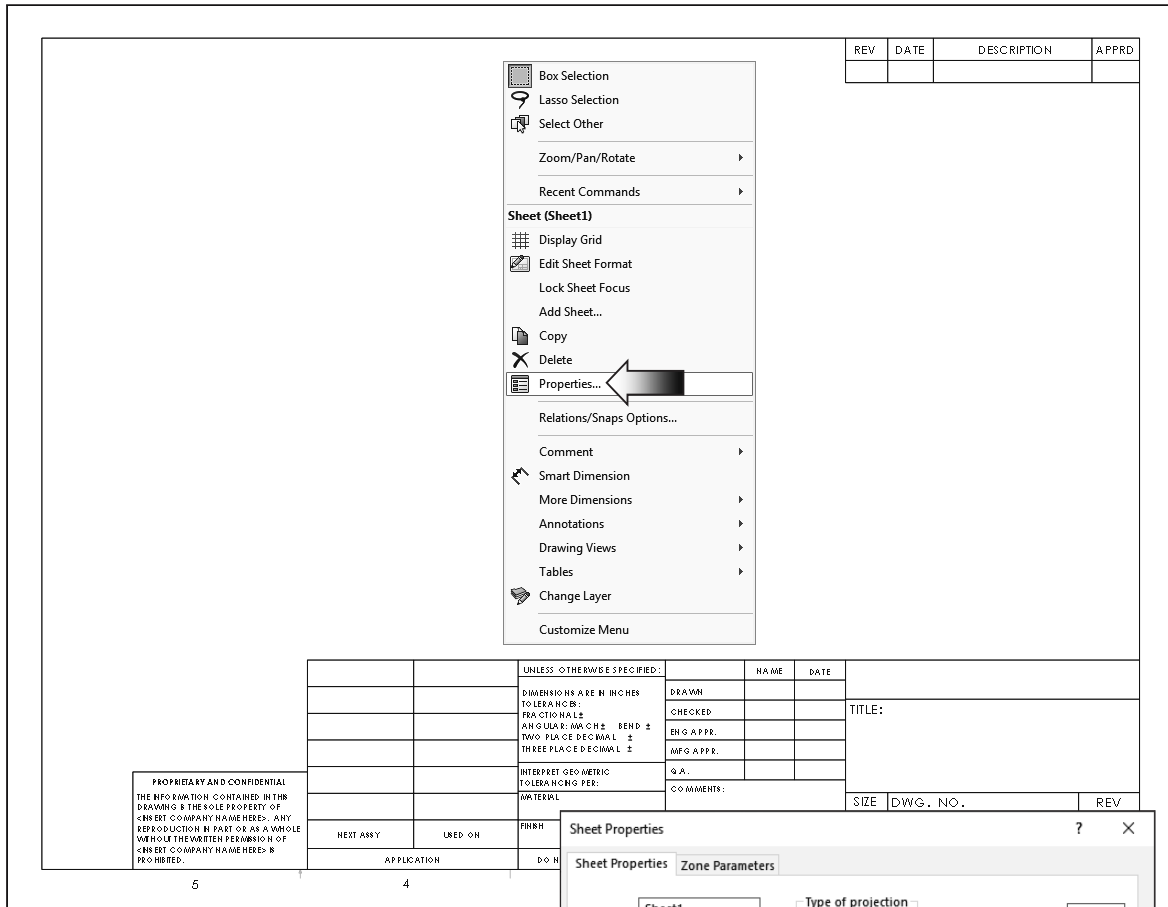

Set the following:

- * **Scale: 1:1**
- * **Third Angle Projection.**
- * **C (ANSI) Landscape.**
- * **Display Sheet Format enabled.**

Click **Apply Changes**.

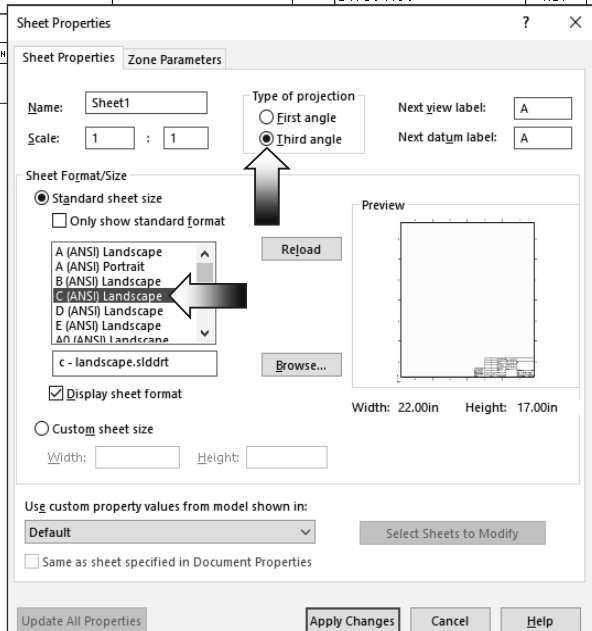

4. Adding the drawing views:

Expand the **View Palette** (arrow) and drag the **Front View** into the drawing approximately as shown.

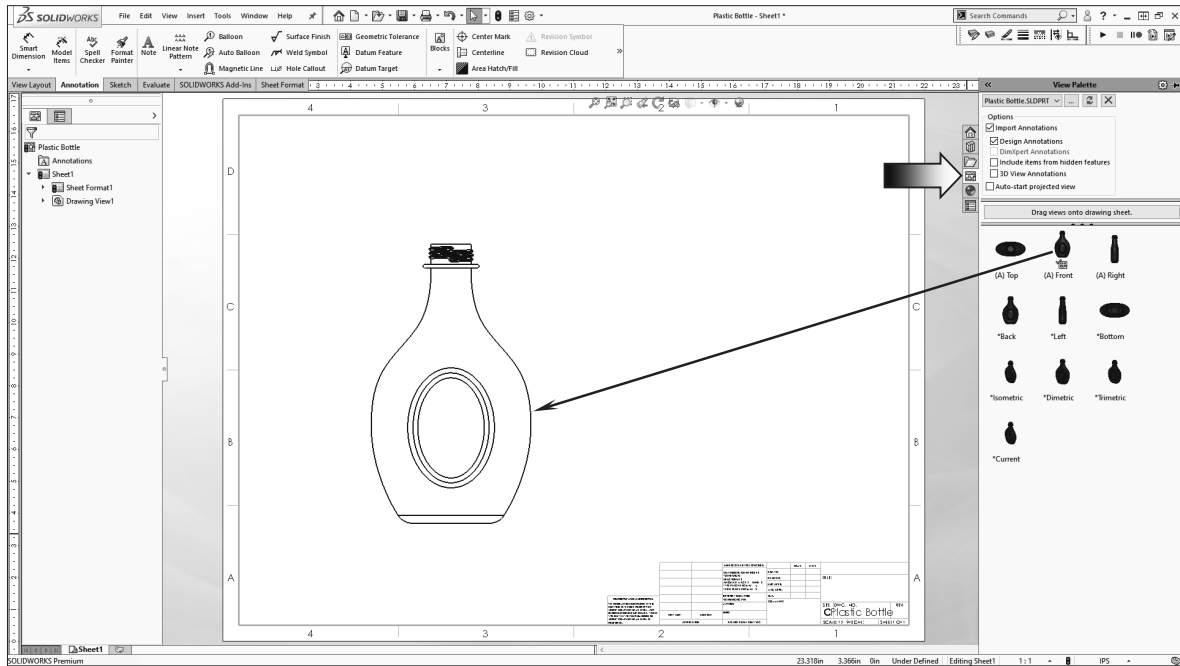

Create an Isometric View by projecting from the Front view, or by dragging and dropping from the View Palette.

Place the Isometric view on the right side of the Front view.

For clarity, change the tangent edges to With-Font (right click the view's border and select Tangent Edges With Font).

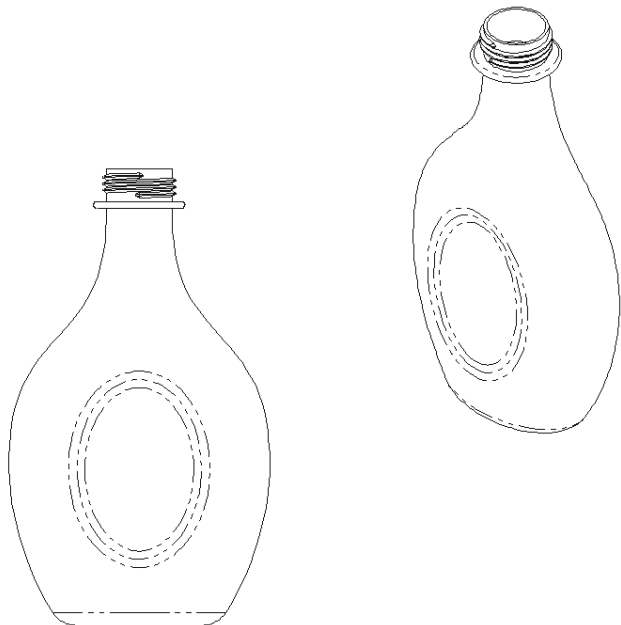

5. Creating a section view:

Switch to the **View Layout** tab.

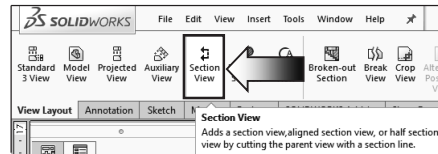

Click the **Section View** command.

For Cutting Line, select the **Vertical** option (arrow).

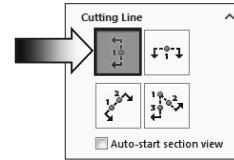

Place the Cutting Line in the center of the Front view and click the **green** check mark (arrow) to accept the line placement.

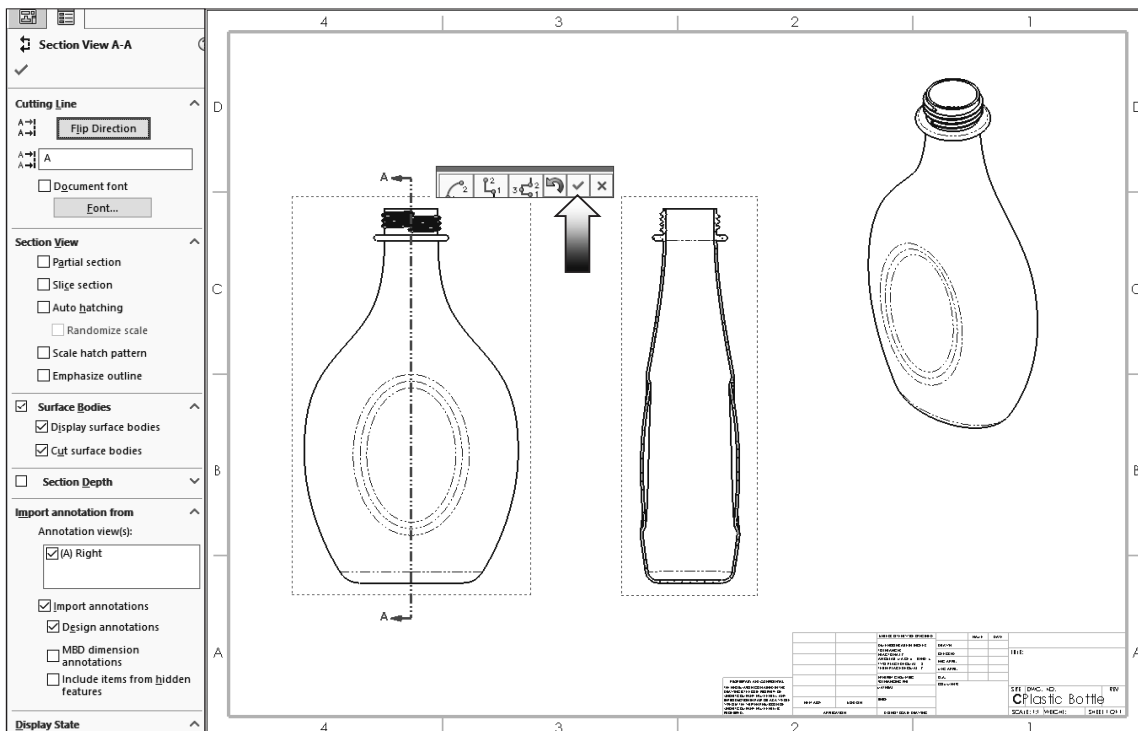

Click Flip Direction if needed, the Section Arrows should be pointing to the left.

Place the Section view on the right side of the Front view.

Move the Isometric view to the upper right hand side. This view is for reference use only.

6. Measuring the surface Perimeter:

Zoom in on the section view; we will need to select the sectioned surface and measure its Perimeter.

Switch to the **Evaluate** tab and click **Measure**.

Locate the **Perimeter** value and enter it here:

_____ inches.

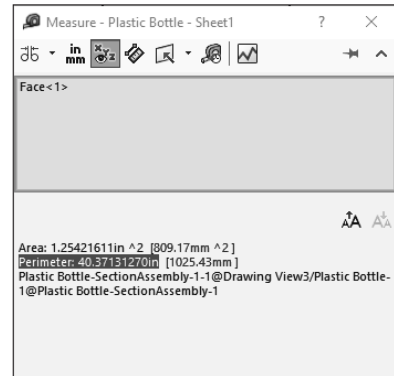
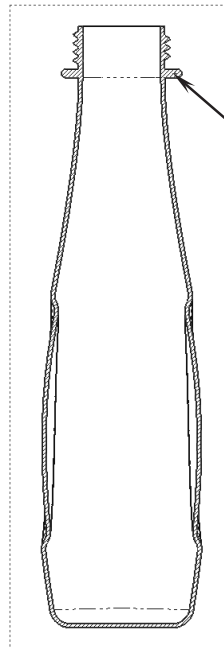
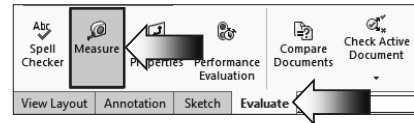

7. Creating an aligned section view:

Double-click the dotted border of the Front view to lock it.

The **Lock View Focus** option allows you to add sketch entities to a view so that when the view is moved, the entities will move with the view. This works well for adding section lines manually.

Switch to the **Sketch** tab and sketch **2 Lines** as shown in the image on the right.

Add the vertical and horizontal dimensions to fully define the sketch. (Multiple lines are often used to create an Aligned Section View.)

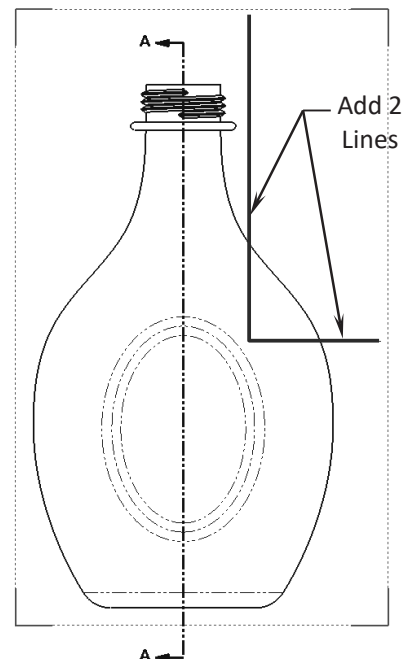

Hold the **Control** key and select the Vertical Line 1st, and then select the Horizontal Line after.

Switch to the **View Layout** tab and select the **Section View** command (arrow).

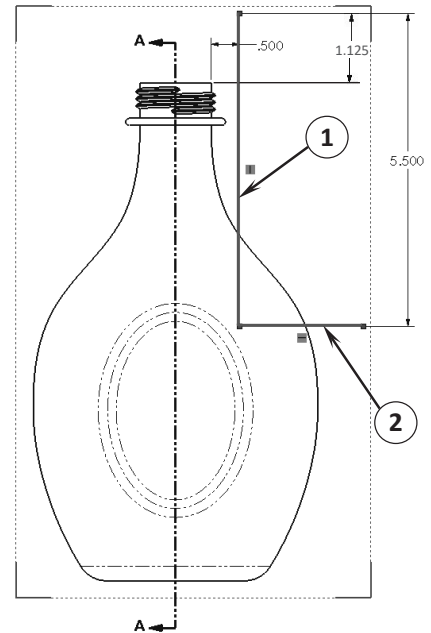
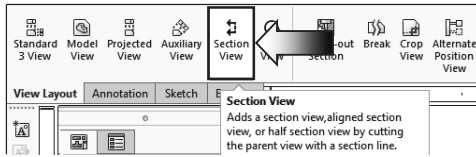

An **Aligned Section View** is created and labeled as **Section B-B**.

Ensure that the Direction Arrows match the image shown below.

Click the **Flip Direction** button if needed (arrow).

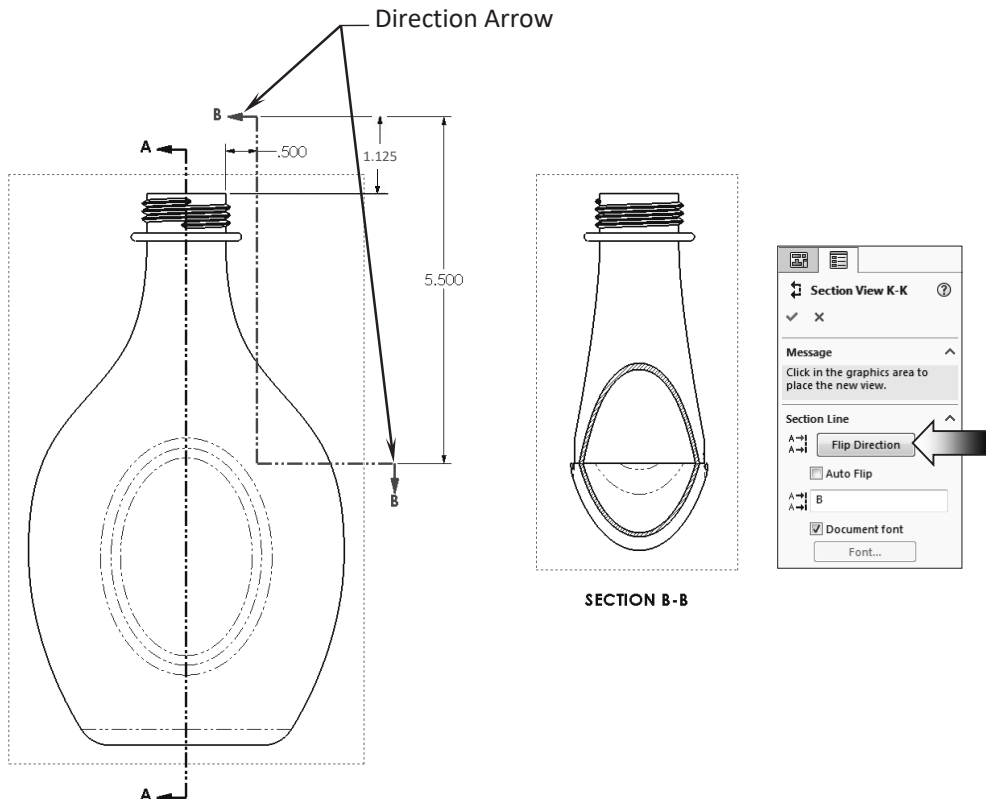

8. Measuring the surface Perimeter:

Zoom in on the section view; we will need to select the upper surface of the Section B-B and measure its perimeter.

Switch to the **Evaluate** tab and click: **Measure**.

Select only the upper face as noted.

Locate the **Perimeter** measurement and enter it here:

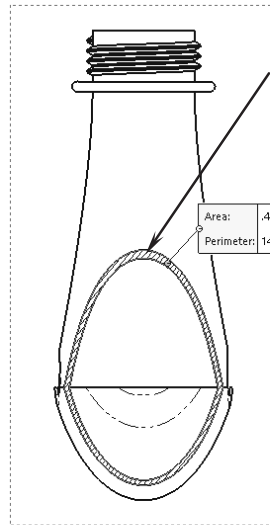

SECTION B-B

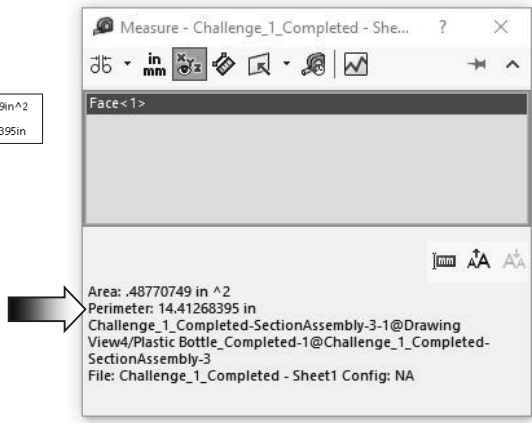
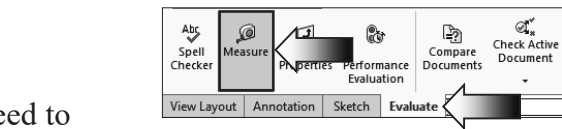

_____ inches.

9. Saving your work:

Select **File / Save As**.

Enter **Challenge_1.slddrw** for the file name.

Click **Save**.

Summary:

The key features to the Challenge 1 are:

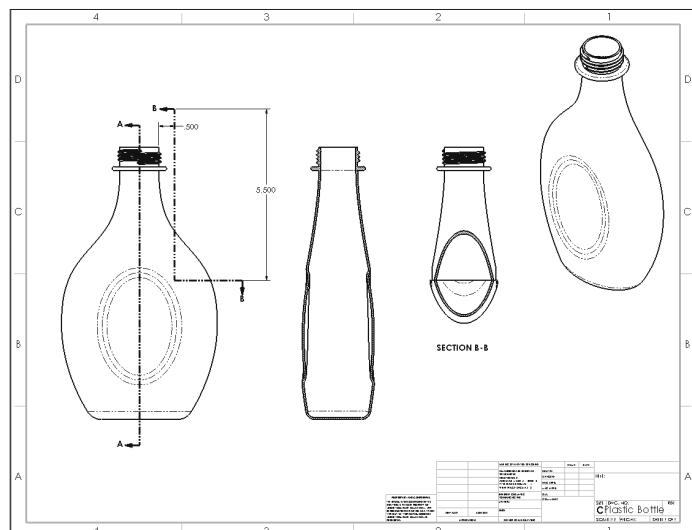

Creating the Section Views and Measuring the Perimeter of the sectioned surfaces.

CHALLENGE 2

1. Opening an assembly document: (This challenge focuses on the orientation modifications and drawing view creation.)

Select **File / Open**.

Browse to the Training Folder and open an assembly document named: **Latch Assembly.sldasm**.

In this Challenge, the orientation of the assembly has been changed to some oblique angle. You will need to come up with a way to find the correct angle and change the orientation back to normal, prior to making the drawing.

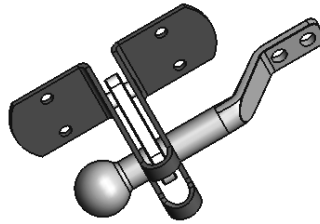

Top View

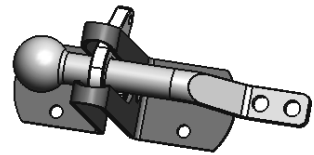

Isometric View

Change to different view Orientations such as the Front, Top, Right, and Isometric view to examine the default orientations of this assembly.

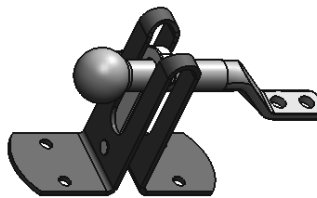

Front View

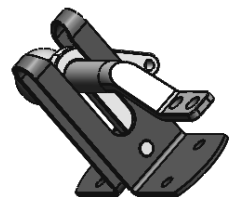

Right View

The Top view will be used to correct the orientation of the assembly.

Select the component **Base SM** and click **Edit Component**.

Rotate the assembly and open a **new sketch** on the upper face as noted.

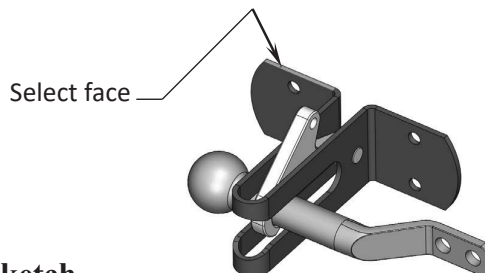

2. Creating the 1st reference sketch:

We will need to rotate the Base_SM to the horizontal position. There are several methods to find the current angle of the Base but we will go with creating a reference sketch approach.

Sketch a **Construction Line** as indicated.

(Press **Control+8** to rotate normal to the sketch face.)

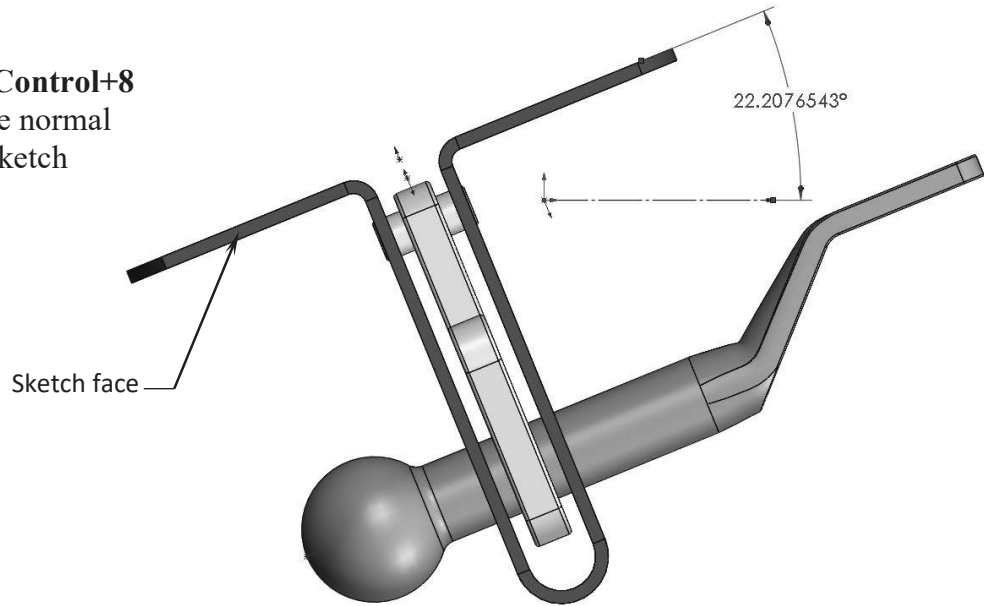

Add a reference angular dimension as shown above.

Change the number of decimals to **5 places**. This angular dimension will be used to rotate the entire assembly to the correct orientation as shown in the sample image below.

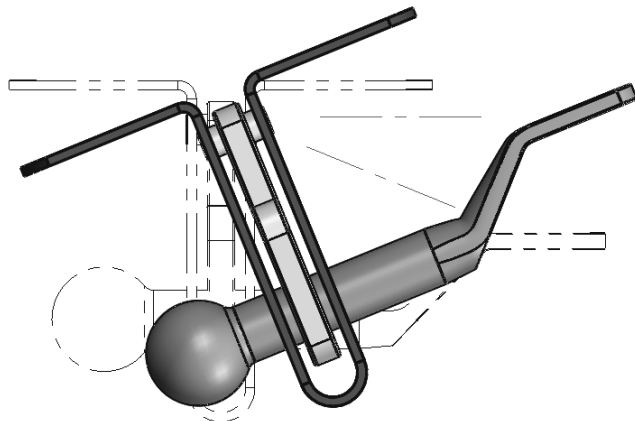
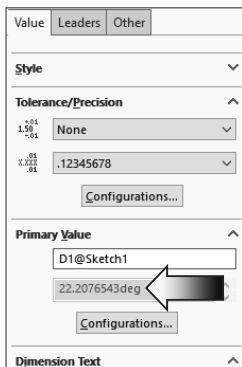

3. Modifying the Arrow Keys angle:

Select **Tools, Option, System Options**.

Select the **View** option and change the angle of the **Arrow Keys** to **22.20765**.

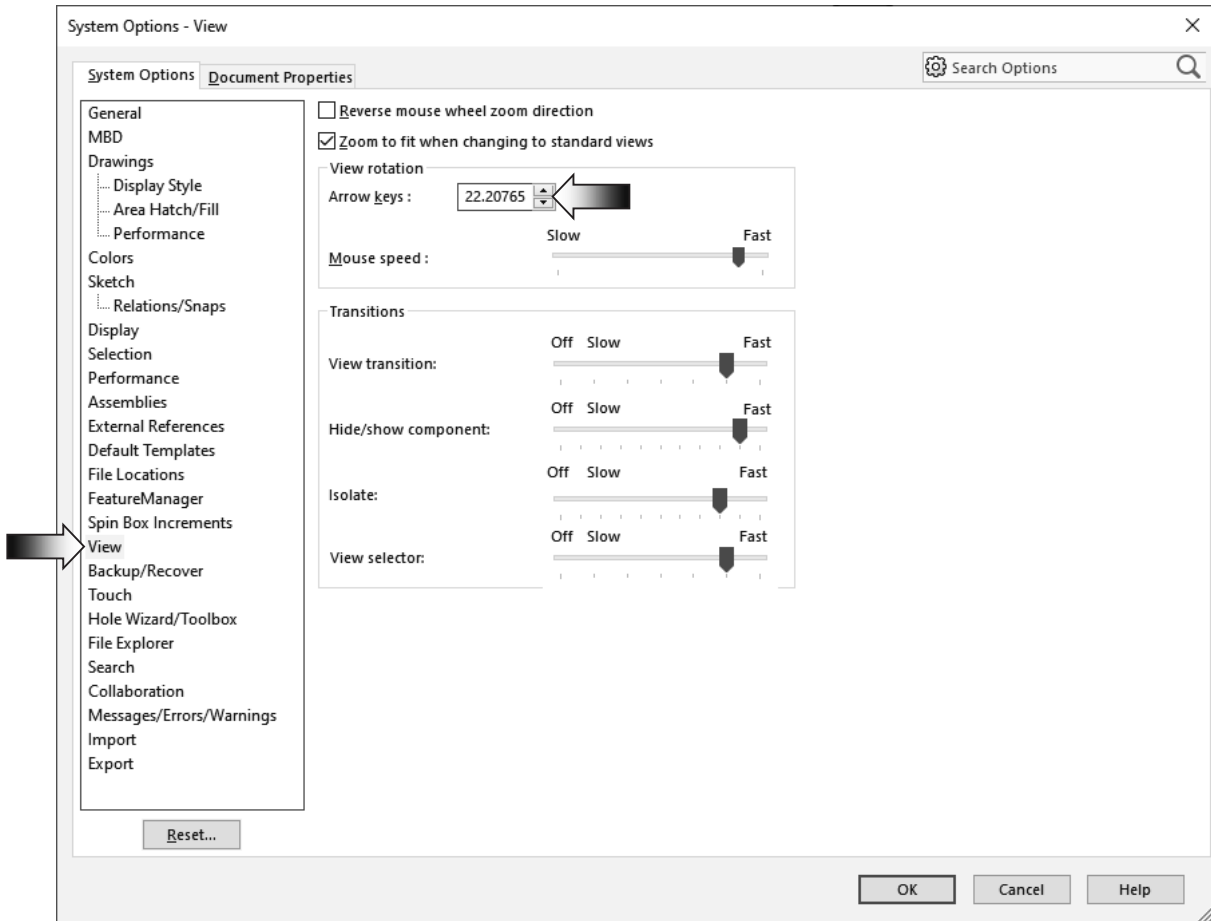

Click **OK**.

At this point, if any of the arrow keys are pressed, the model will rotate precisely 22.20765° each time. To rotate “normal to screen” hold down the Alt key while pressing one of the 4 arrow keys.

Exit the sketch.

4. Changing the Top view orientation:

Remain in the **Top** view orientation.
Hold down the **Alt** key and press the **Left Arrow** key once.

The entire assembly is rotated 22.20765° clockwise.
This is the correct orientation for the top view.

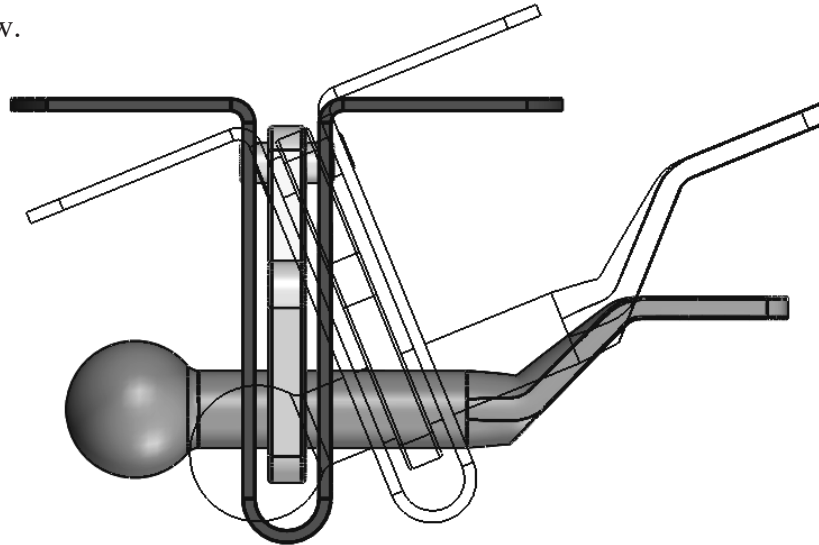

5. Creating the 2nd reference sketch:

Select the face on the right side of the Base_SM and open a **new sketch**.

Press **Control+8** to rotate normal to the sketch face. This is the current Right view orientation.

Sketch a horizontal **centerline** and add a reference angular dimension.

Exit the sketch.

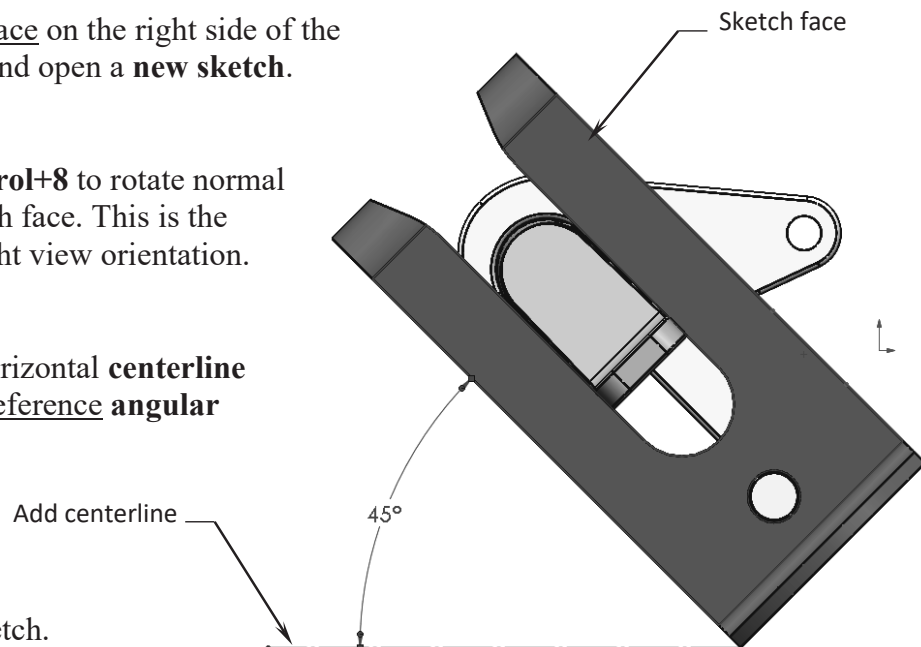

6. Modifying the Arrow Keys angle:

Select **Tools, Option, System Options.**

Select the **View** option and change the angle of the **Arrow Keys** to **45.00**.

Click **OK**.

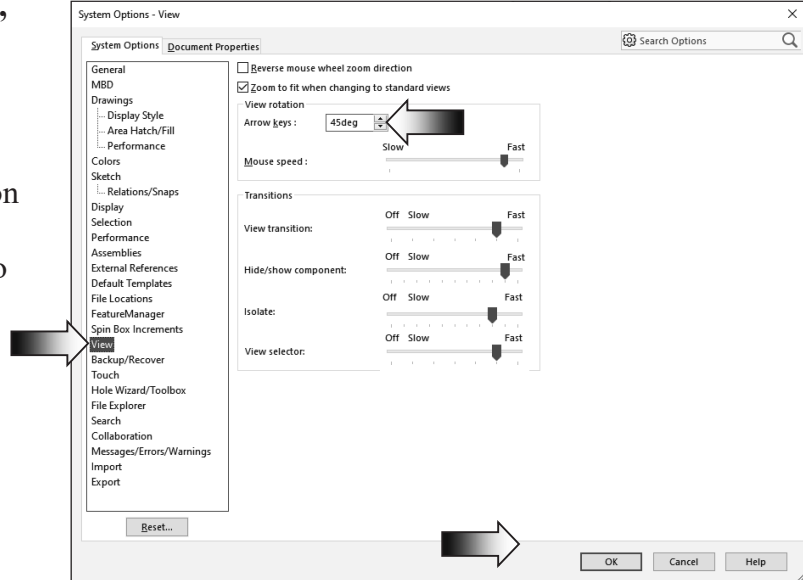

7. Changing the Right view orientation:

Hold down the **Alt** key and press the **Right Arrow** key once.

The entire assembly is rotated 45° counterclockwise.
This is the correct orientation for the right view.

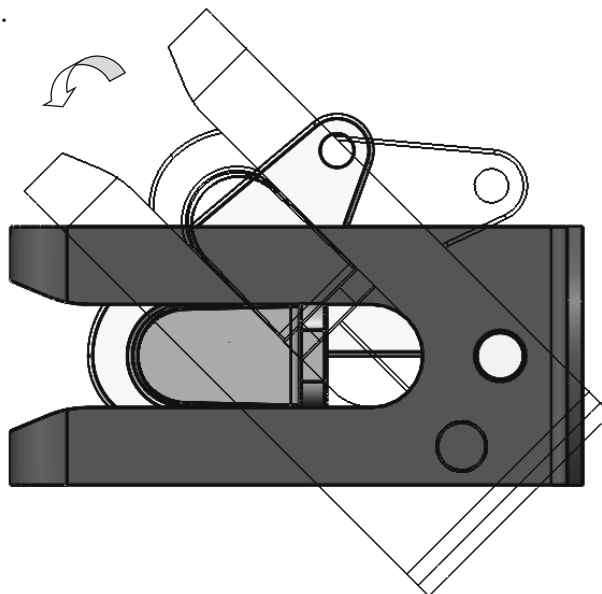

8. Saving a new named view:

Custom views can be created and saved in the model or in an assembly document so that they can be displayed in a drawing at a later time.

The views are saved in the Orientation dialog and get carried over to the drawing and listed on the Properties tree.

Press the **Spacebar** to access the Orientation dialog.

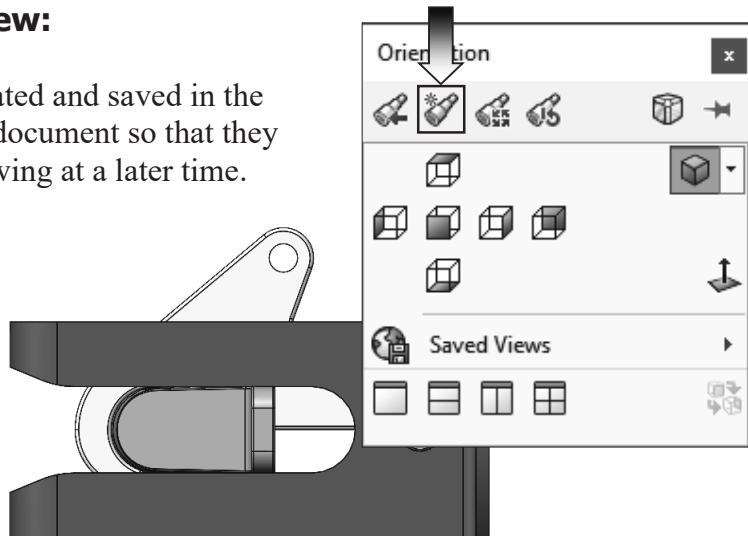

Click the **New View** button .

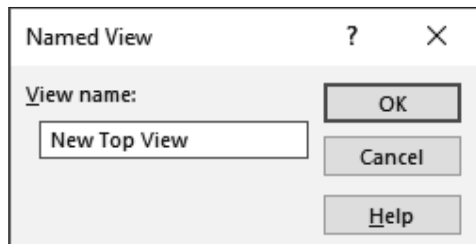

Enter: **New Top View** in the Named View dialog and press **OK**.

The new view is saved and displayed in the Orientation dialog.

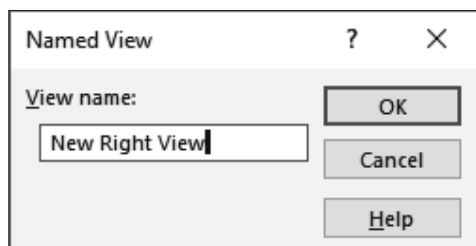
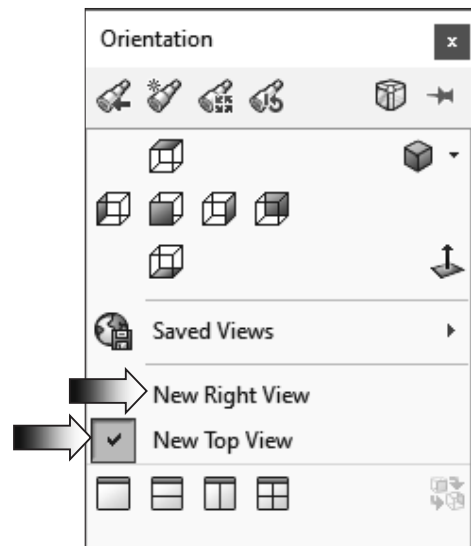

Repeat the last step and save another Named View called: **New Right View**.

Click **OK** and save the assembly document.

9. Making a drawing from assembly:

Select **File / Make Drawing from Assembly** (arrow).

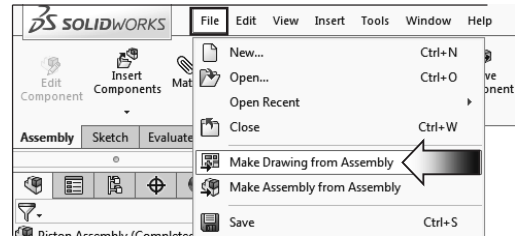

Select the **Drawing** template.

Click **OK**.

Right-click inside the drawing and select **Properties**.

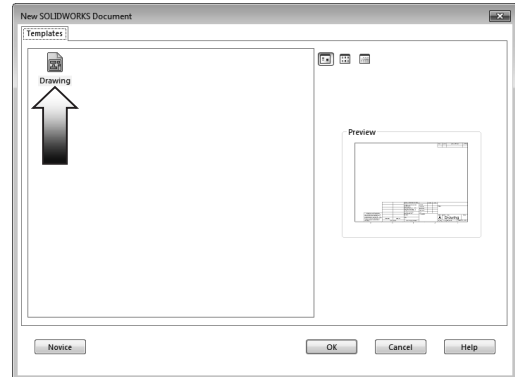

Change the paper size to **C-Landscape**.

Change the **Scale** to **1:1**.

The drawing sheet includes a title block with the following tables:

REV	DATE	DESCRIPTION	APPRD

UNLESS OTHERWISE SPECIFIED:	NAME
DIMENSIONS ARE IN INCHES	DRAWN
TOLERANCES:	CHECKED
FRACTIONALS	
ANGULAR: FINISH ±	ENG APPR.
TWO PLACE DECIMAL ±	
THREE PLACE DECIMAL ±	INFO APPR.
	G.A.
INTERPRET GEOMETRIC TOLERANCES PER:	COMMENTS:
ASME Y14.5	
MATERIAL	

PROPERTY AND CONFIDENTIAL THE INFORMATION CONTAINED IN THIS DRAWING IS THE SOLE PROPERTY OF ARBET COMPANY. NO PART OF ANY REPRODUCTION IN PART OR AS A WHOLE WITHOUT THE WRITTEN PERMISSION OF ARBET COMPANY IS PERMITTED.	DATE	BY

AFFILIATION	USED ON	NUMBER

DO NOT SCALE DRAWING

Sheet Properties dialog box details:

- Name: Sheet1
- Scale: 1 : 1
- Type of projection: Third angle
- Sheet Format/Size: **c - landscape.sldprt**
- Width: 22.00in, Height: 17.00in

Set the Type of Projection to **Third Angle**.

Click **Apply Changes**.

10. Adding the first drawing view:

Drag and drop the Top drawing view from the View Palette.

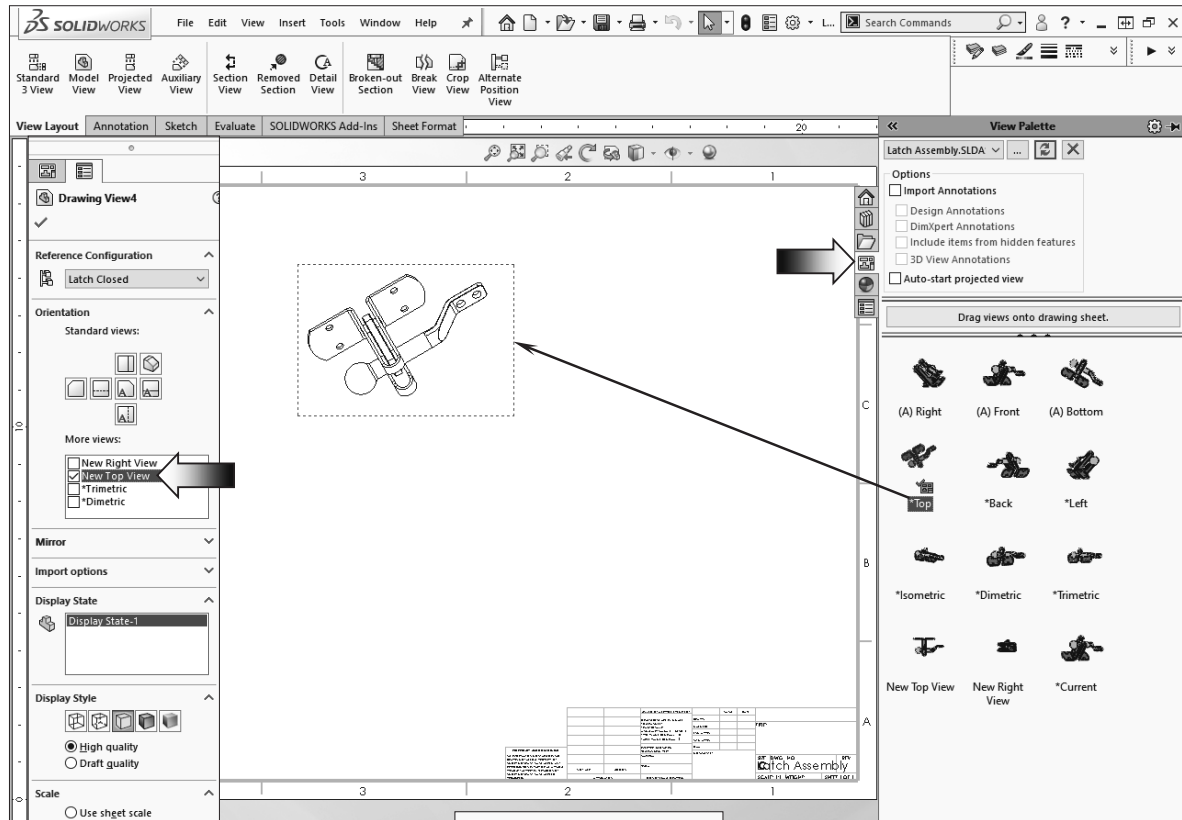

Locate the **Orientation** section on the Property tree.

Select the named view **New Top View** checkbox. The Top view is switched to the new orientation.

Click **OK**.

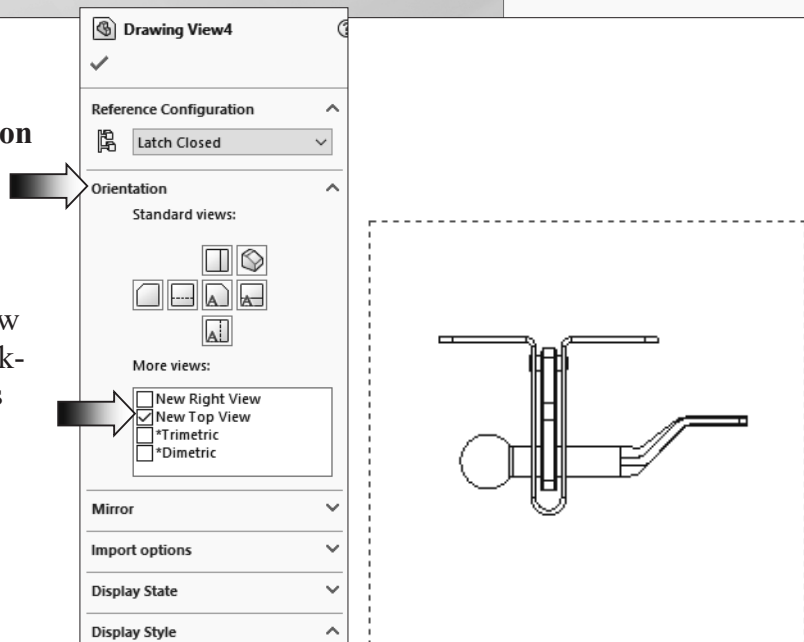

11. Creating the projected drawing views:

New drawing views can now be projected vertically or horizontally from the new view.

Switch to the **View Layout** tab and click the **Projected View** command.

Click the dotted border of the **Top** view to start the projection.

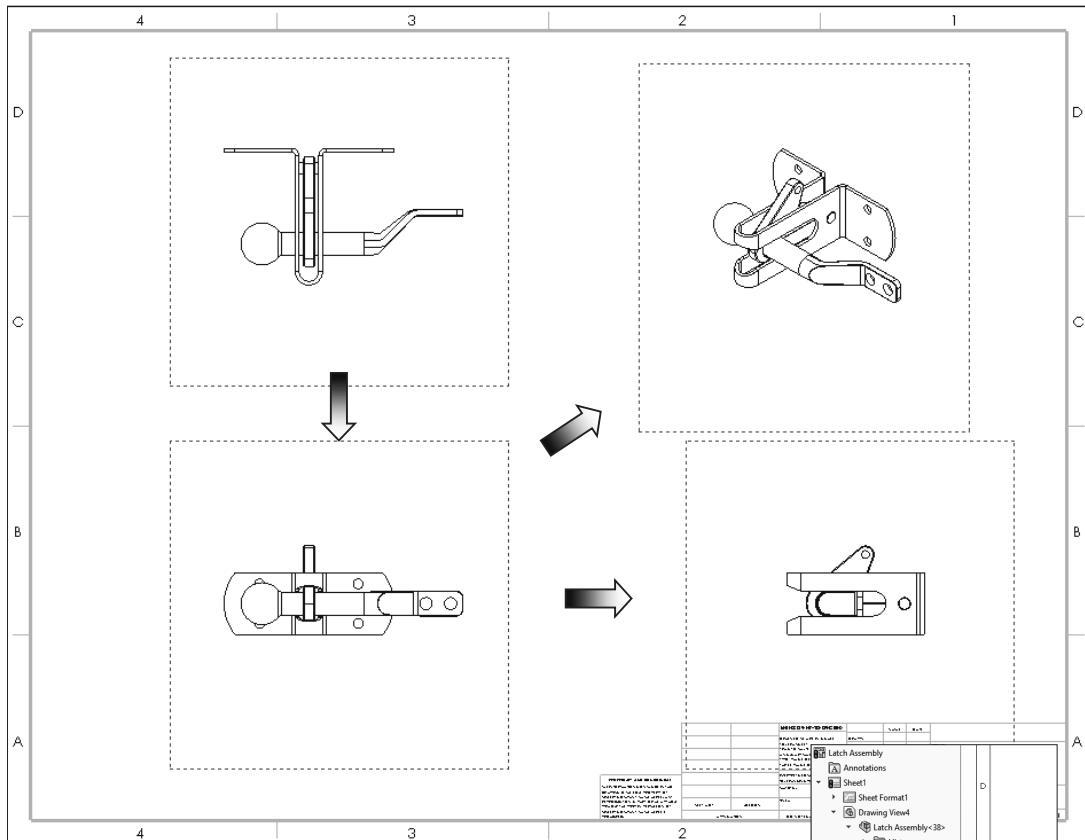
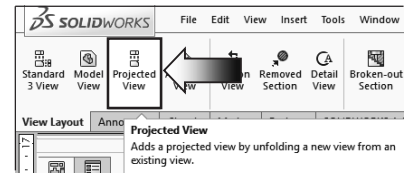

Move the mouse cursor downward to see the preview of the Front view. Place the Front view below the Top view approximately as shown above.

Additionally, create a **Right View** and an **Isometric View** and position them as shown above.

Show the **Sketch1** and **Sketch2** on the Feature tree .

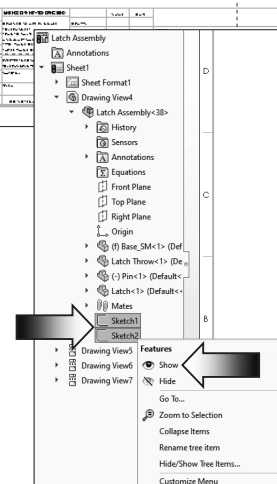

12. Adding reference lines:

Zoom in on the lower right corner of the drawing.

Right-click anywhere inside the drawing and select **Lock Sheet Focus**.

This forces the new lines to be part of the sheet. If any of the drawing view is moved, the added line will not move.

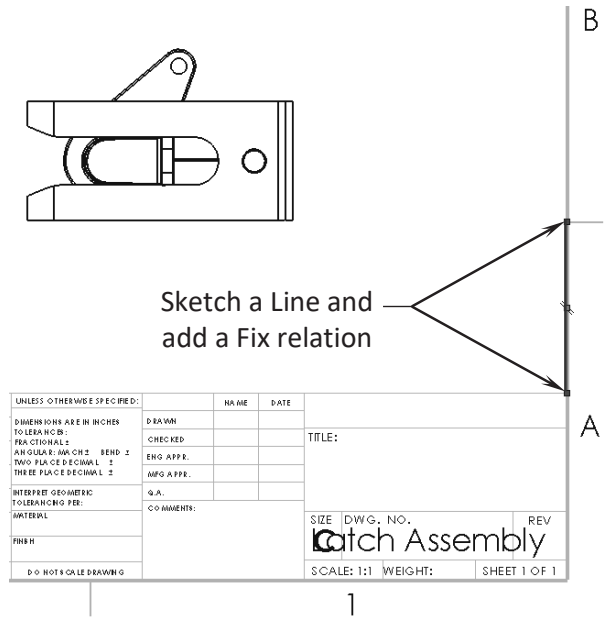
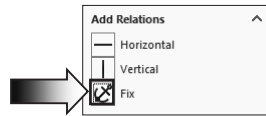
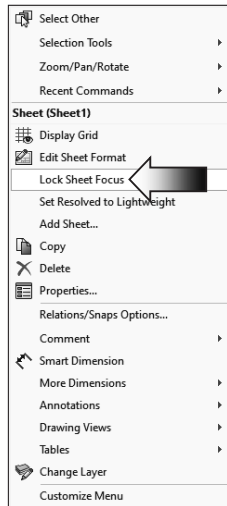

Sketch a vertical **Line** exactly on the inner border line as shown.

Add a **Fix** relation to the line so that it will not move.

Double-click the dotted border of the right view to **Lock View Focus**. This will force the new line and its dimensions to be part of the view. If the drawing view is moved, the line and its dimension will also move with it.

Sketch a **second Line** and add two dimensions as shown.

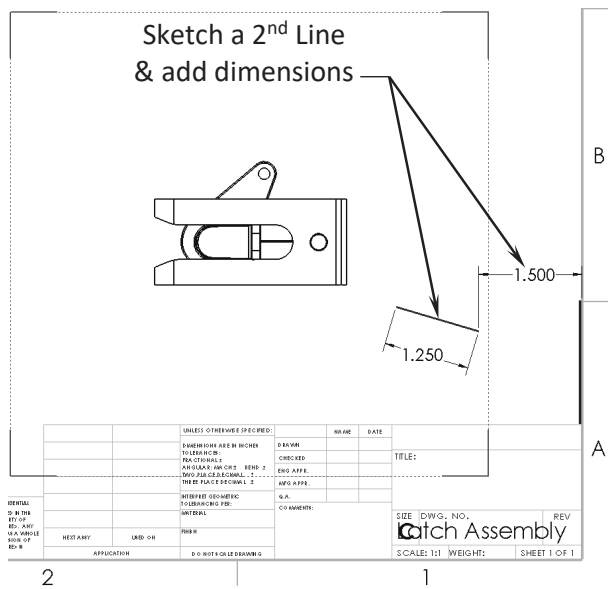

13. Adding an angular dimension:

Create an angular dimension between the 2nd line and the outer edge of the Latch.

Change the angle to **56.44°**.

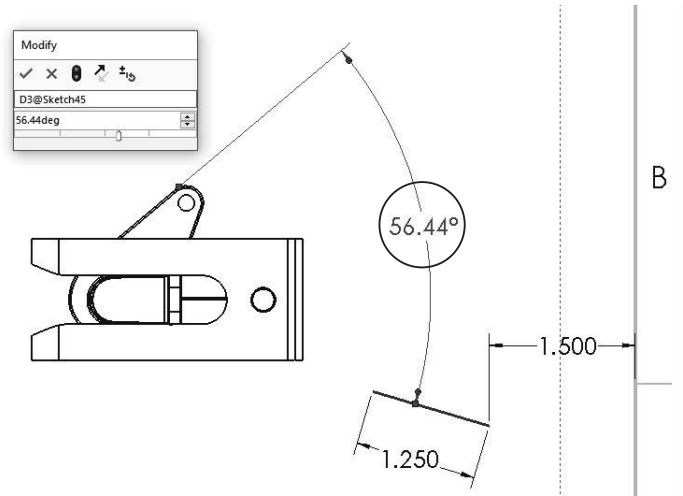

14. Finding the value of X:

Add a reference dimension between the left endpoint of the 2nd line and the edge on the right side of the Right drawing view.

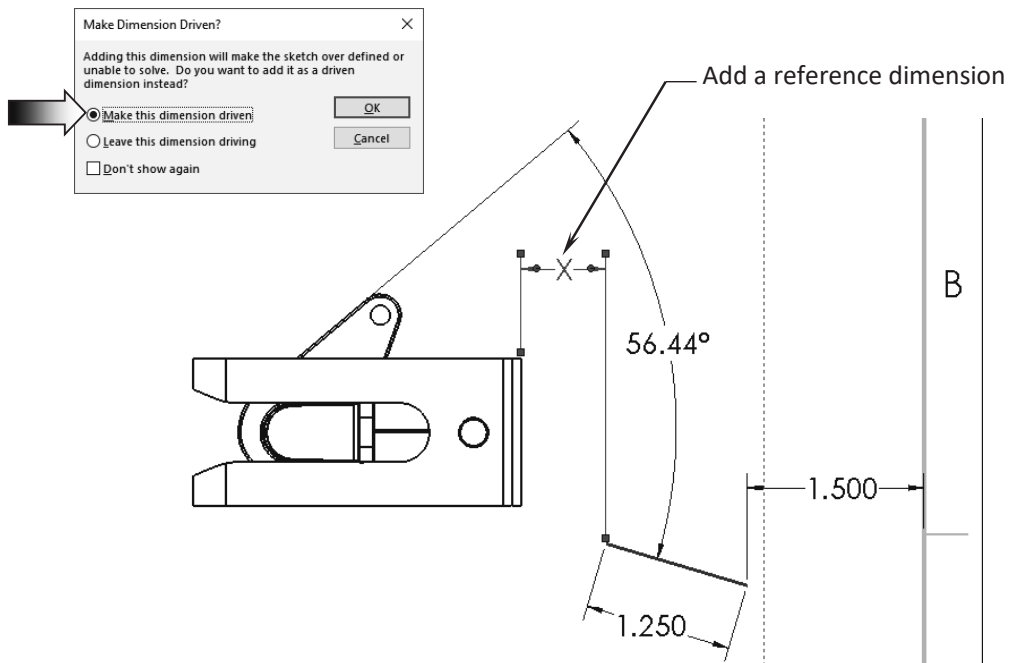

Enter the value of the **dimension X** here: _____ in.

15. Creating a section view:

Double-click the dotted border of the **Right** drawing view to lock the view focus.

Sketch a **Line** and add a **Parallel** relation to the outer edge of the Latch.

Switch to the **View Layout** tab and click **Section View**.

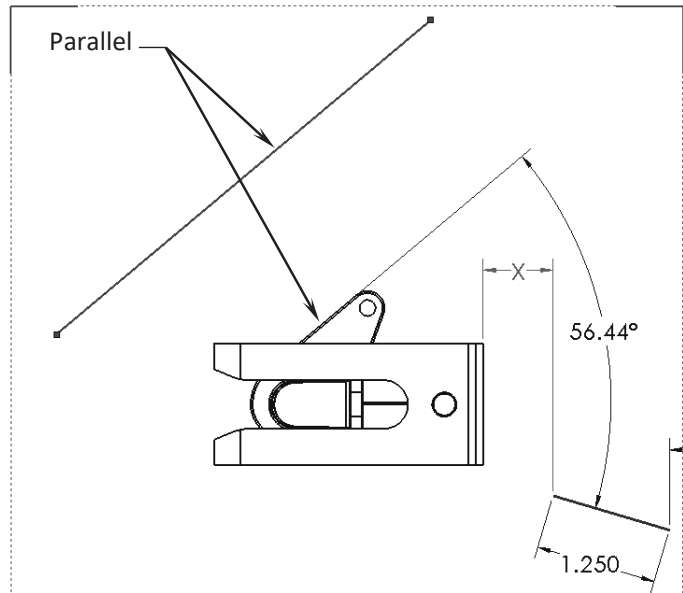

Click **OK** to accept the default options in the **Section Scope** dialog box.

Place the section view approximately as shown.

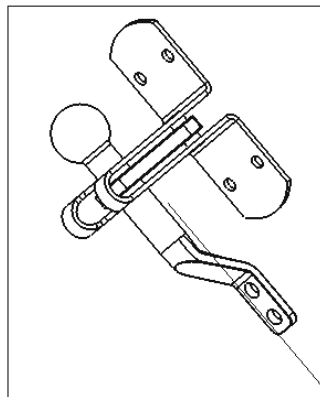

The direction arrows should be pointing towards the right drawing view.

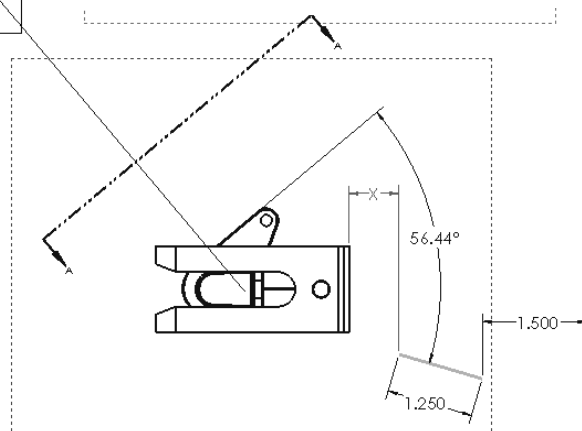
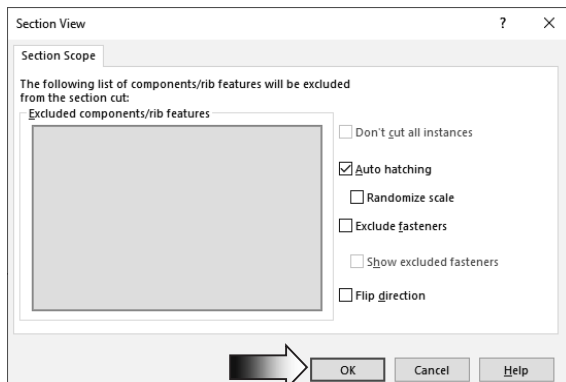

16. Finding the value of Y:

Double-click the dotted border of the **Right** drawing view to lock its view focus.

Convert the horizontal edge of the **Base_SM** to a line (image below).

Add an angular dimension between the edge of the **Base_SM** and the converted line as shown below.

Click **OK** to accept the reference dimension.

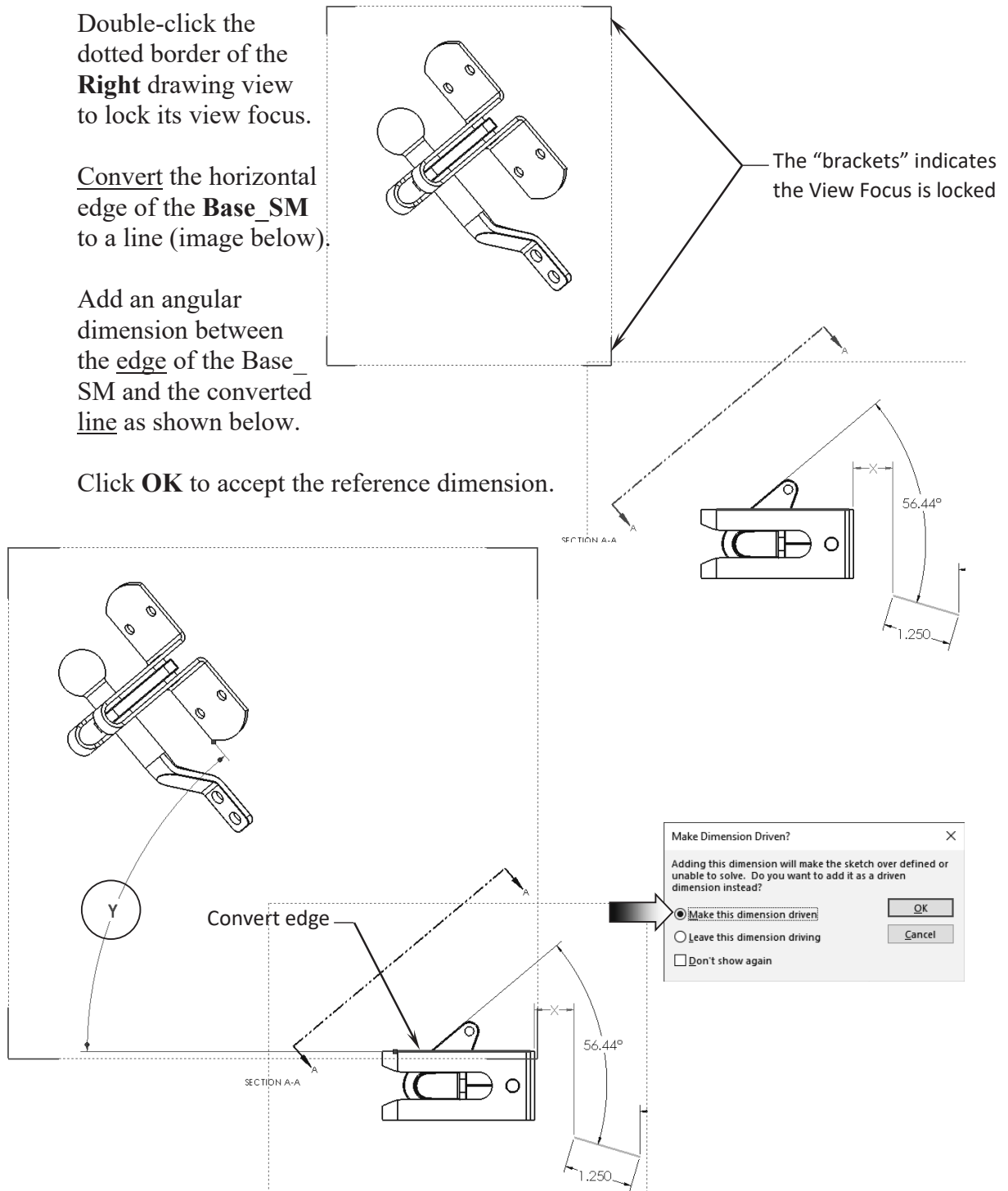

Enter the value of the **dimension Y** here: _____ deg.

17. Creating an Alternate Position view:

The dimensions and the lines in the Right drawing view are hidden for clarity.

Switch to the **View Layout** tab and click: **Alternate Position View**.

Select the **Right** drawing view.

Click **Existing-Configuration** and select **Latch Open** from the drop-down list.

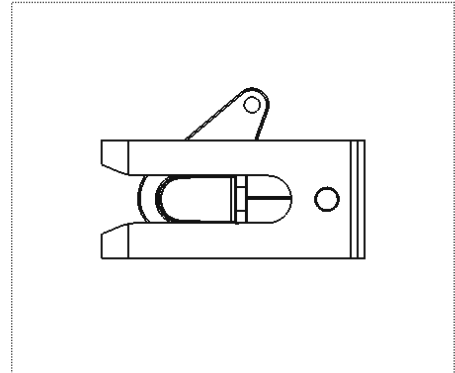
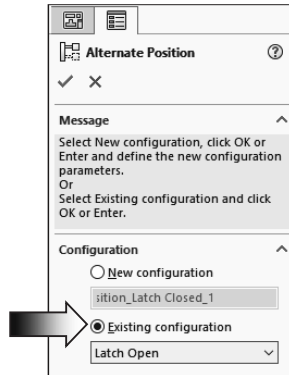

Click **OK**.

An alternate position view is displayed in phantom line style, under the Right drawing view.

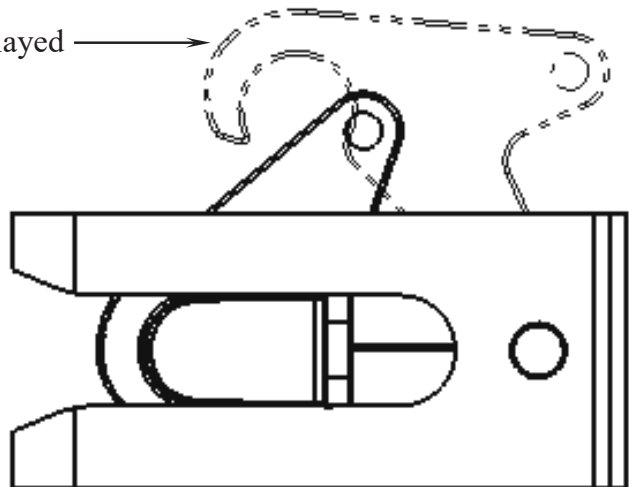

18. Saving your work:

Select **File / Save As**.

Enter **Challenge_2.slddrw** for the file name.

Click **Save**.

Summary:

The key features to the Challenge 2 are:

Creating the drawing views and finding the right orientations and return the views back to normal before creating the drawing views.

Lock and Unlock the View Focus so that reference geometry can be added for measuring and locating other references.

CHALLENGE 3

This challenge examines your skills on the following:

- * Creating an assembly drawing.
- * Adding balloons.
- * Customizing the bill of materials.

1. Opening a drawing document:

Select **File / Open**.

Browse to the Training Folder and open the drawing document named:
Deck Assembly.slddrw.

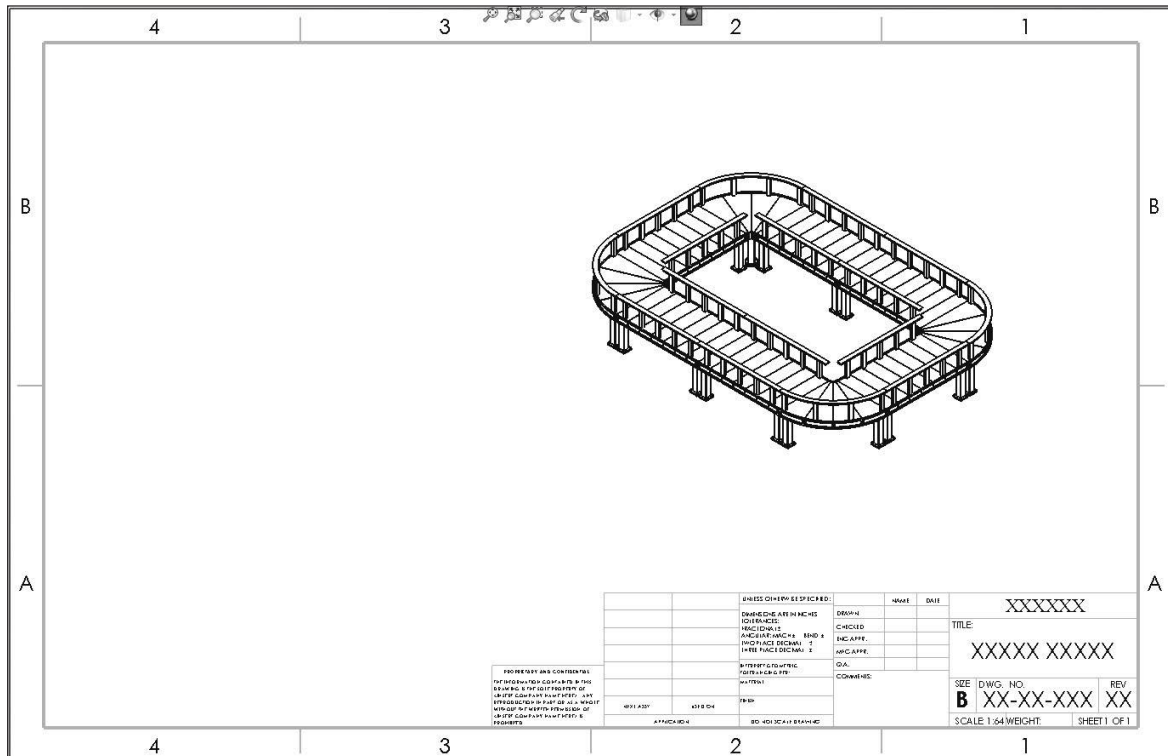

There is only 1 Isometric drawing view in this drawing.
A Bill of Materials and Balloons need to be added to the drawing view.

2. Inserting the balloons:

Balloons are used to identify the item numbers in the bills of materials.

Switch to the **Annotation** tab and click the **Auto Balloon** command . Select the Isometric view's border.

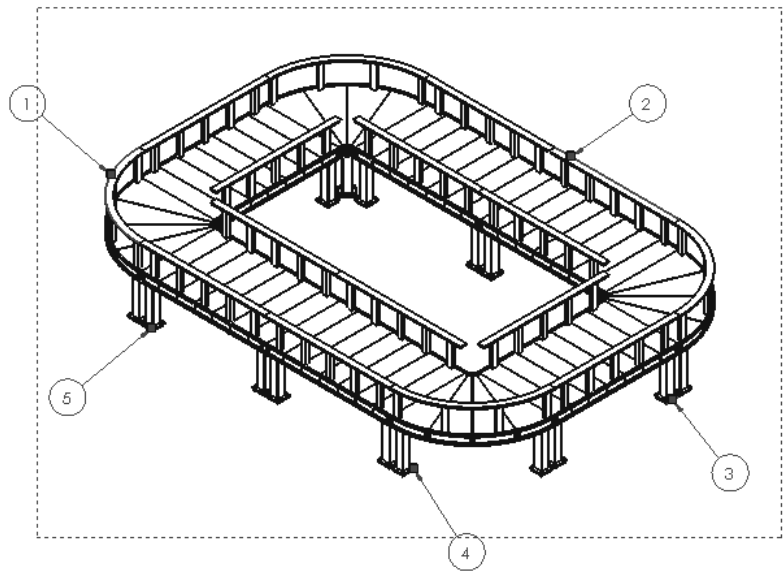
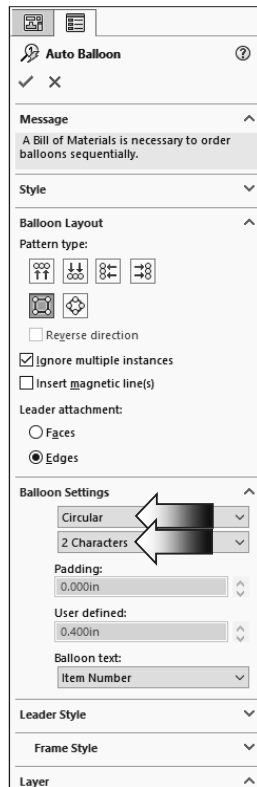

By default, each unique component gets a balloon assigned to it automatically.

Change the balloon settings to **Circular**, **2 characters** and click **OK** (arrows).

The item numbers reflect the order of the components listed in the top level assembly. Changes done to the order of the components in the assembly feature tree will populate the balloons and the bill of materials.

3. Adding a bill of materials:

In an assembly drawing, a bill of materials is created to display the item numbers, quantities, part numbers, and custom properties of the assembly.

The bill of materials should be linked to a drawing view, so click the dotted border of the Isometric view to activate it.

From the **Annotation** tab, select **Tables / Bill of Materials**.

For Table Template, select **BOM-Standard**.

For BOM Type, select **Parts Only**.

For Part Configuration Grouping, select **Display as One Item Number**.

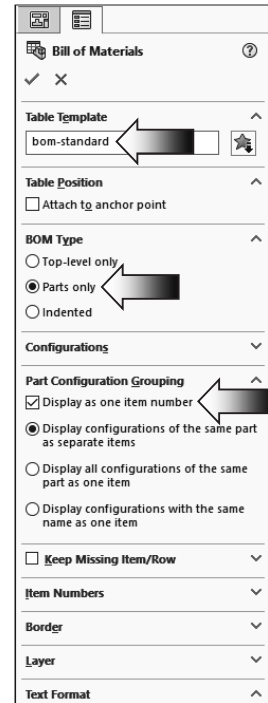

Click **OK**.

Place the Bill of Materials on the left side of the drawing view.

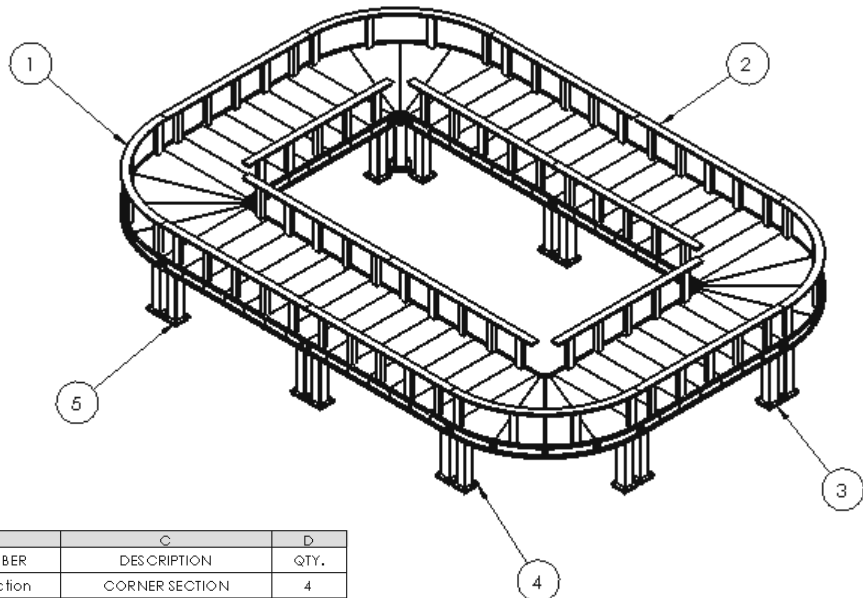

	A	B	C	D
1	ITEM NO.	PART NUMBER	DESCRIPTION	QTY.
2	1	Corner Section	CORNER SECTION	4
3	2	Section1	SECTION1	6
4	3	Foot Plate	FOOT PLATE	36
5	4	Regular FW 0.75	Flat Washer, Regular	144
6	5	HHBOLT 0.6250-18x1.25x1.25-N	Heavy Hex Bolt	144

SOLIDWORKS 2025 | CSWP Advanced Preparation | Drawing Tools

	A	B	C	D
1	ITEM NO.	PART NUMBER	DESCRIPTION	QTY.
2	1	Corner Section	CORNER SECTION	4
3	2	Section1	SECTION1	6
4	3	Foot Plate	FOOT PLATE	36
5	4	Regular FW 0.75	Flat Washer, Regular	144
6	5	HHBOLT 0.6250-18x1.25x1.25-N	Heavy Hex Bolt	144

Zoom in on the Bill of materials. We will change the Part Number column to include the actual part numbers that were assigned earlier, at the part level.

4. Changing custom properties:

Double-click column header **B** to access the Custom Property options.

Double-click

	A	B	C	D
1	ITEM NO.	PART NUMBER	DESCRIPTION	QTY.
2	1	Corner Section	CORNER SECTION	4
3	2	Section1	SECTION1	6
4	3	Foot Plate	FOOT PLATE	36
5	4	Regular FW 0.75	Flat Washer, Regular	144
6	5	HHBOLT 0.6250-18x1.25x1.25-N	Heavy Hex Bolt	144

Change the Column Type to Custom Property.

For Property Name, select **PartNo** from the list.

	A	B	C	D
1	ITEM NO.		DESCRIPTION	QTY.
2	1		CORNER SECTION	4
3	2		SECTION1	6
4	3	01-240-613	FOOT PLATE	36
5	4	01-240-615	Flat Washer, Regular	144
6	5	01-240-614	Heavy Hex Bolt	144

The part numbers for each component are displayed in column B. Adjust the column width by dragging the row divider .

Drag to adjust

	A	B	C	D
1	ITEM NO.	PartNo	DESCRIPTION	QTY.
2	1	01-240-611	CORNER SECTION	4
3	2	01-240-610	SECTION1	6
4	3	01-240-613	FOOT PLATE	36
5	4	01-240-615	Flat Washer, Regular	144
6	5	01-240-614	Heavy Hex Bolt	144

5. Adding a Project column:

Right-click the column header **D** and select **Insert / Column Right** (arrow).

	A	B	C	D
1	ITEM NO.	PartNo	DESCRIPTION	QTY.
2	1	01-240-611	CORNER SECTION	4
3	2	01-240-610	SECTION1	6
4	3	01-240-613	FOOT PLATE	36
5	4	01-240-615	Flat Washer, Regular	144
6	5	01-240-614	Heavy Hex Bolt	144

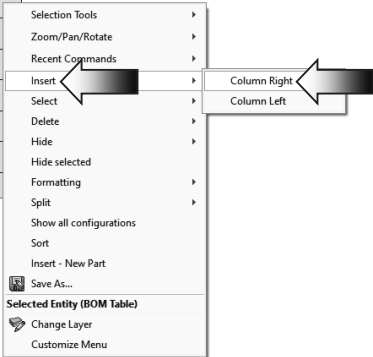

Change the Column Type to: **Custom Property**.

For Property Name, select **Project** from the list.

The project **Deck Design** is displayed in the new column.

	A	B	C	D	E
1	ITEM NO.	PartNo	DESCRIPTION	QTY.	Project
2	1	01-240-611	CORNER SECTION	4	Deck Design
3	2	01-240-610	SECTION1	6	Deck Design
4	3	01-240-613	FOOT PLATE	36	Deck Design
5	4	01-240-615	Flat Washer, Regular	144	Deck Design
6	5	01-240-614	Heavy Hex Bolt	144	Deck Design

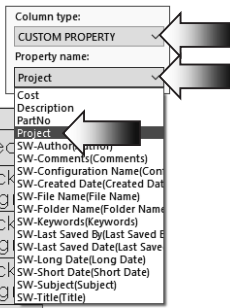

6. Adding a column for Cost:

Right-click the column header **E** and select **Insert / Column Right** (arrow).

Change the Column Type to **Custom Property**.

	A	B	C	D	E
1	ITEM NO.	PartNo	DESCRIPTION	QTY.	Project
2	1	01-240-611	CORNER SECTION	4	Deck Design
3	2	01-240-610	SECTION1	6	Deck Design
4	3	01-240-613	FOOT PLATE	36	Deck Design
5	4	01-240-615	Flat Washer, Regular	144	Deck Design
6	5	01-240-614	Heavy Hex Bolt	144	Deck Design

For Property Name, select **Cost** from the list.

The cost for each component is displayed in the new column.

	A	B	C	D	E	F
1	ITEM NO.	PartNo	DESCRIPTION	QTY.	PROJECT	Cost
2	1	01-240-611	CORNER SECTION	4	Deck Design	\$60.00 each
3	2	01-240-610	SECTION1	6	Deck Design	\$80.00 each
4	3	01-240-613	FOOT PLATE	36	Deck Design	\$5.00 each

ITEM NO.	PART NUMBER	DESCRIPTION	QTY.	Project	Cost
1	Corner Section	CORNER SECTION	4	Deck Design	\$60.00 each
2	Section1	SECTION1	6	Deck Design	\$80.00 each
3	Foot Plate	FOOT PLATE	36	Deck Design	\$5.00 each
4	Flat Washer	FLAT WASHER, REGULAR	144	Deck Design	45 CENTS EACH
5	Hex Bolt	HEAVY HEX BOLT	144	Deck Design	\$1.75 EACH

XXXXXXXX

TITLE

XXXXXXXX XXXXXX

SIZE (DWG. NO.) REV

B XX-XX-XXXX XX

SCALE: 1:64 (HEIGHT) SHEET 1 OF 1

7. Creating a linked note:

Switch to the **Annotation** tab and click **Note**.

Click on the upper face of one of the handrails to attach the note.

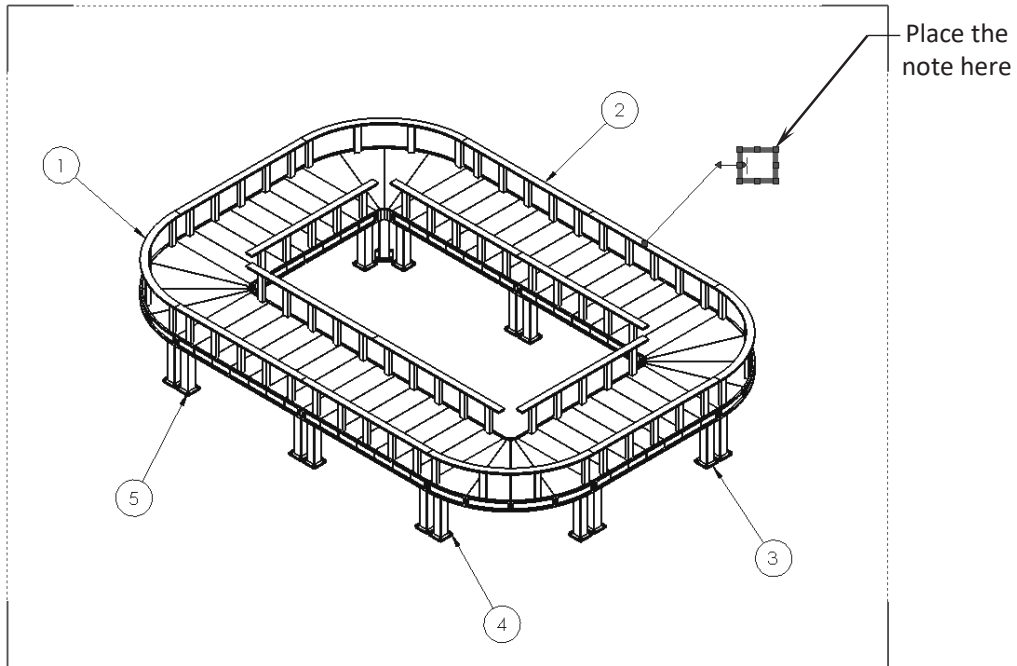

Click the **Link to Property** button.

Under Use Custom Property From, select the **Model Found Here** option.

For Property Name, select **Finish**. The text of the note reads:
Waterproof Coating, Natural.

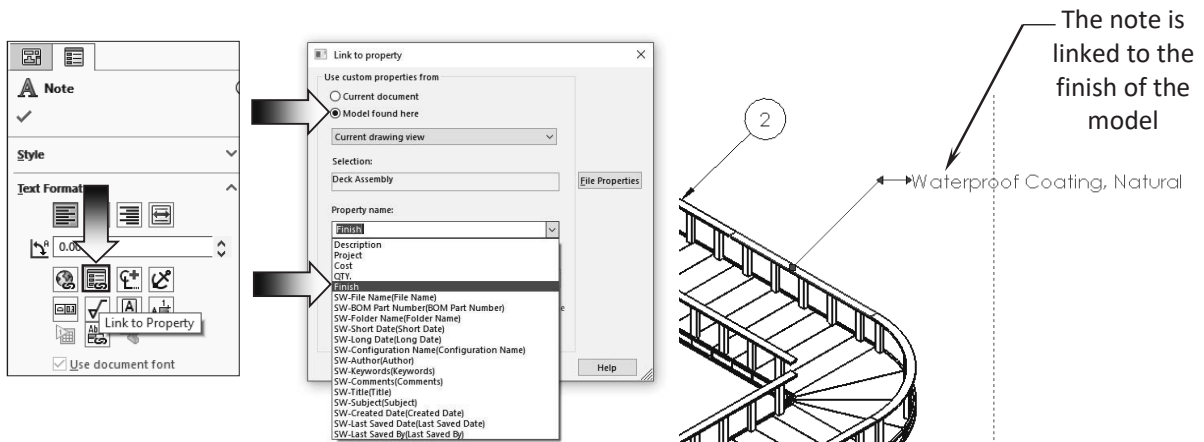

8. Saving your work:

Select **File, Save As.**

Enter **Challenge_3** for the file name.

Click **Save.**

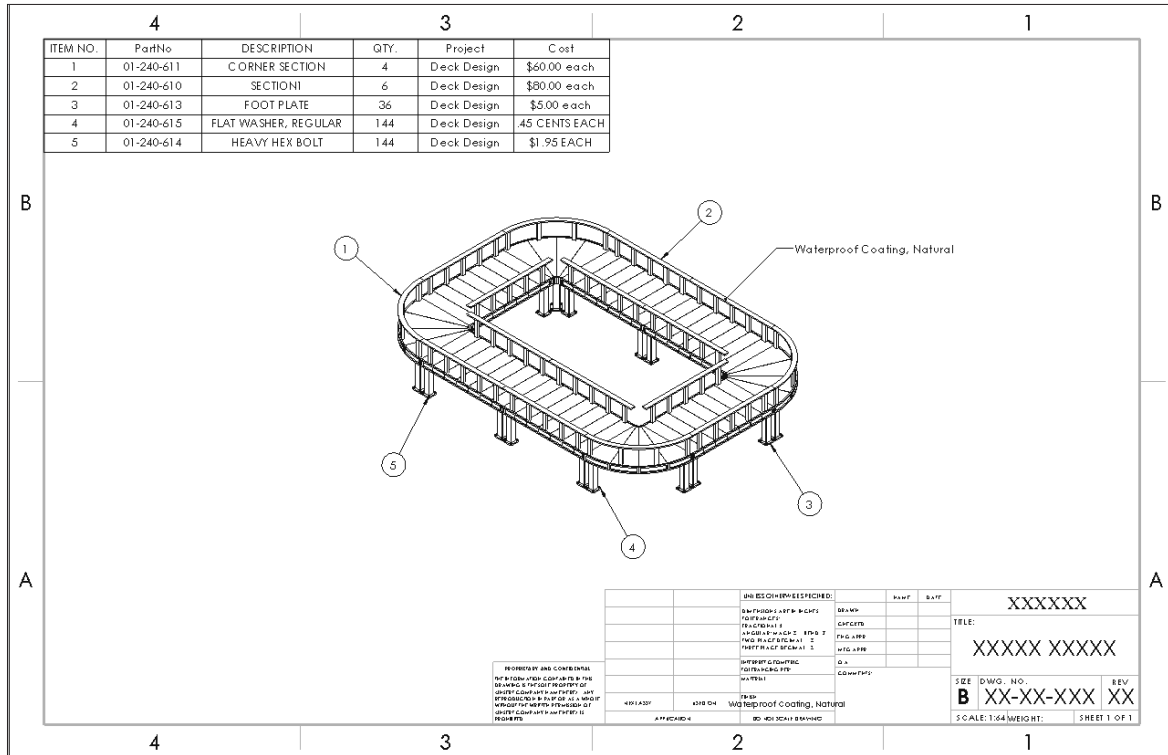

Summary:

The key features to the Challenge 3 are:

- Creating an assembly drawing
- Adding balloons
- Inserting a Bill of materials
- Changing the custom properties
- Adding new columns
- Creating a linked note

CHALLENGE 4

This challenge examines your skills on the following:

- * Hide/Show components in a drawing
- * Adding projection dimensions

1. Opening a drawing document:

Select **File / Open**.

Browse to the Training Folder and open the drawing document named:
Water Valve Assembly.slddrw.

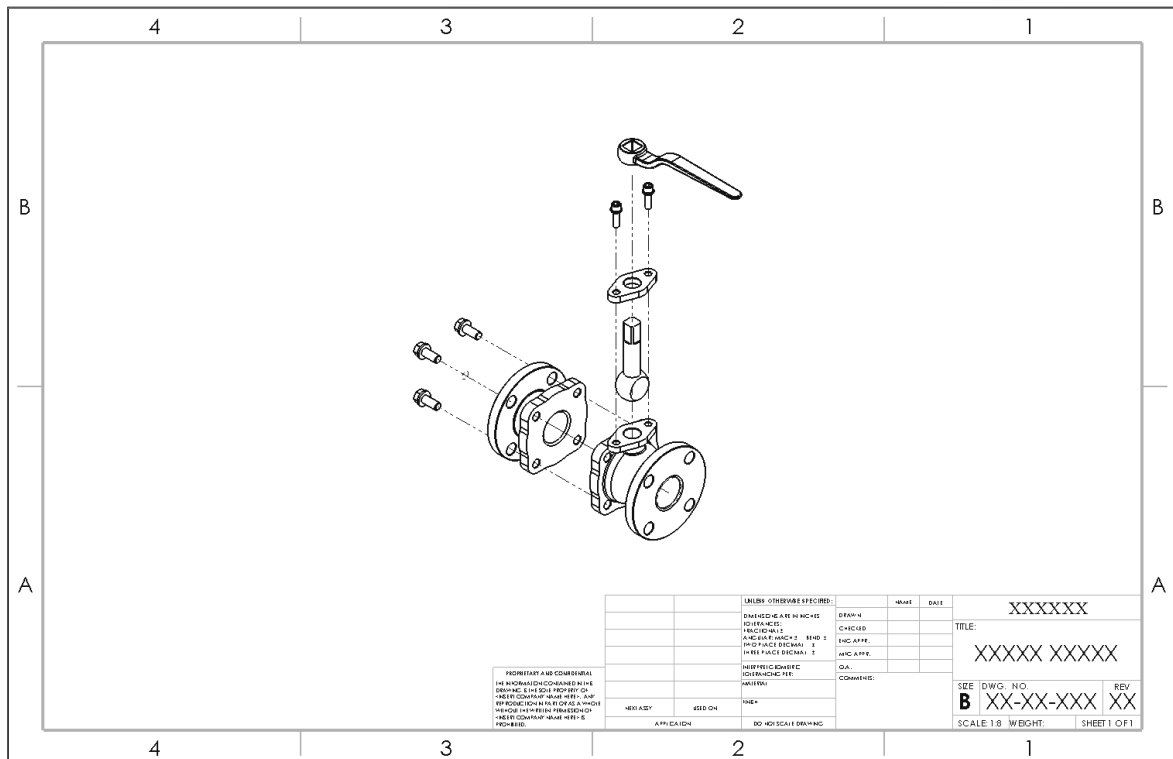

There are some components hidden from the drawing view.
Determine which components are hidden.

2. Finding the hidden components:

Right-click on the dotted border of the Isometric view and select **Properties**.

Click the **Hide/Show Components** tab.

Select which components are hidden:

- | | |
|---|--|
| <input type="checkbox"/> Outlet Housing | <input type="checkbox"/> Inlet Housing |
| <input type="checkbox"/> Flange | <input type="checkbox"/> Ball Valve |
| <input type="checkbox"/> Lock Lever | <input type="checkbox"/> Handle |
| <input type="checkbox"/> Cap Screw | <input type="checkbox"/> Hex Bolt |

Right-click inside the dialog box and select **Delete** to unhide the two components from the drawing view.

Click **OK**.

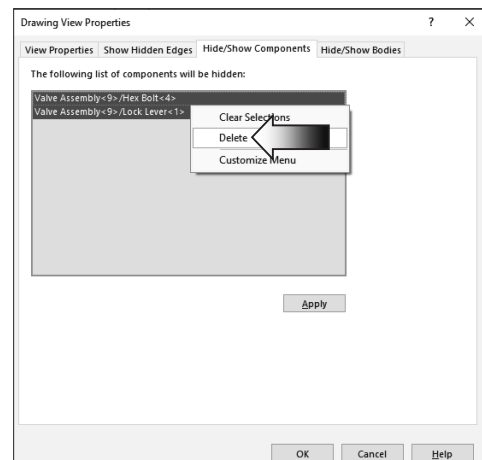
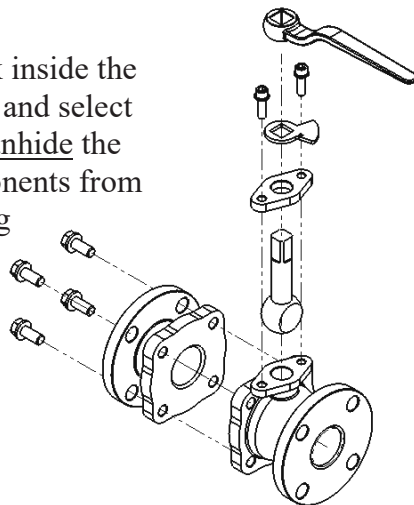
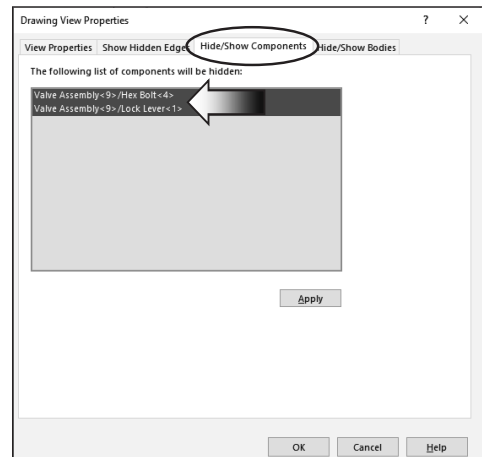
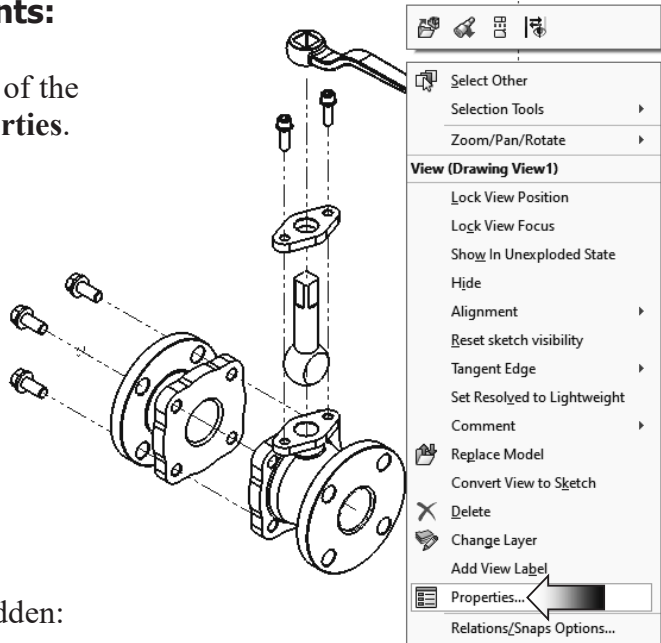

3. Adding an angular dimension:

Select the Isometric view's dotted border and change the Dimension Type to **Projected** (arrow).

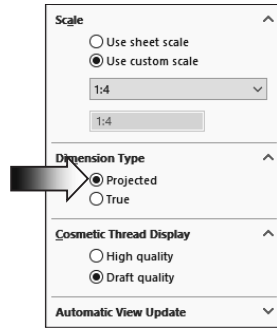

Add an angular dimension between the edges of the **Handle** and the **Flange**.

Enter the angle value here: _____ deg.

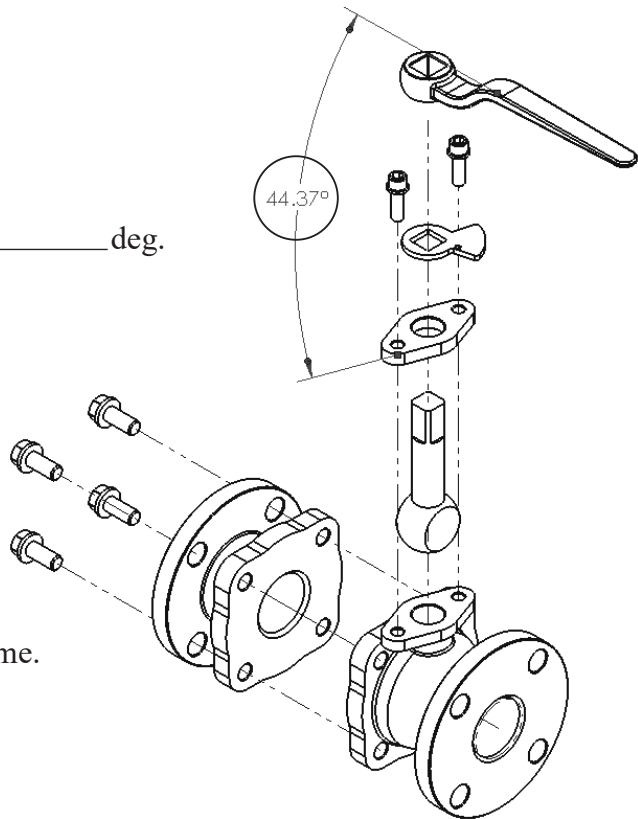

4. Saving your work:

Select **File, Save As**.

Enter **Challenge_4** for the file name.

Click **Save**.

Summary:

The key features to the Challenge 4 are:

Hide/Show the hidden components.

Add a Projected dimension for inspection.

CHALLENGE 5

This challenge examines your skills on the following:

- * Creating a Broken Out Section view
- * Inserting the model dimensions
- * Measuring the perimeter of a surface

1. Opening a drawing document:

Select **File / Open**.

Browse to the Training Folder and open the drawing document named: **Helidrone.slddrw**.

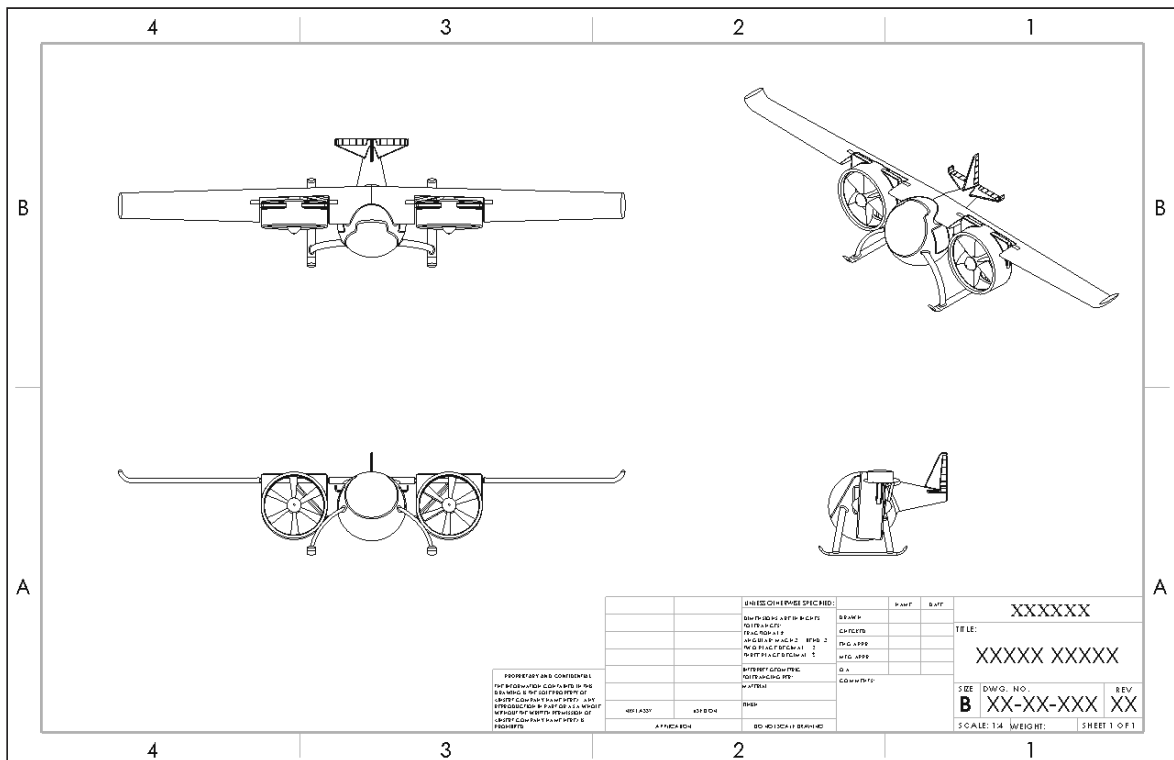

There are 4 standard views in this drawing, the Front, Top, Right, and Isometric views. The Top drawing view will be used to create the Broken-Out Section view.

2. Creating a Broken-Out Section view:

Sketch a **Circle** on the **Top** drawing view and add the 3 dimensions as shown in the image below.

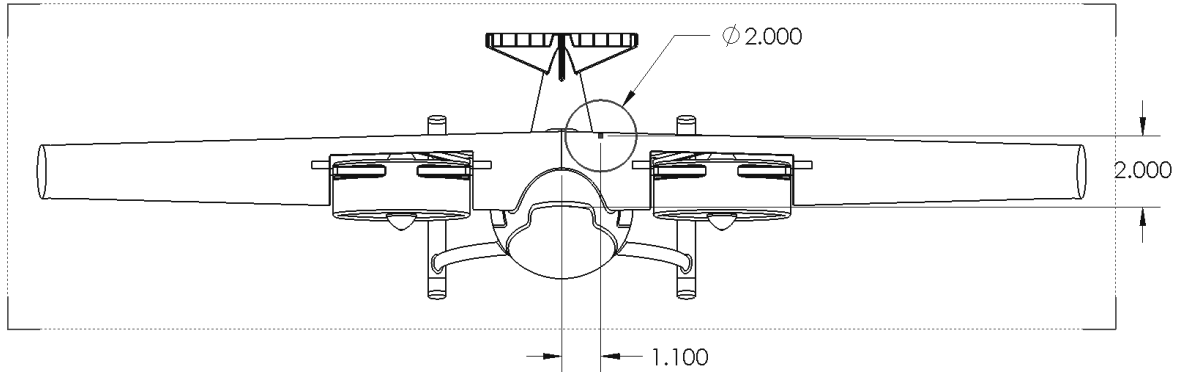

Switch to the **View Layout** tab and click **Broken Out Section**.

Click **OK** in the **Section Scope** dialog box.

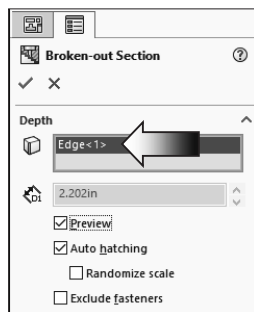
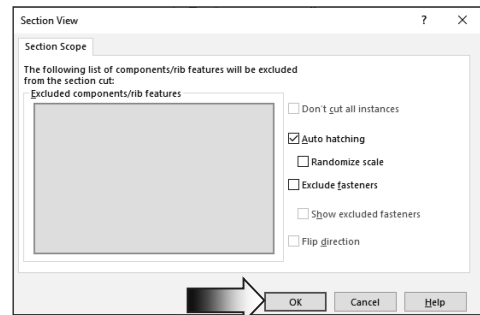

For Section Depth, select the top edge of the tail as noted below.

Click **OK**.

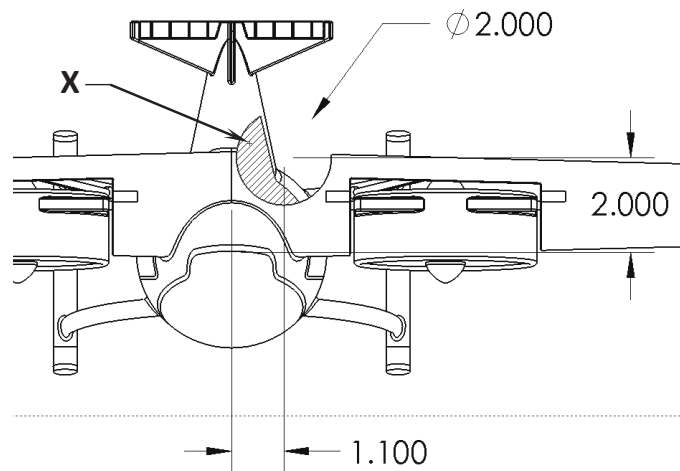
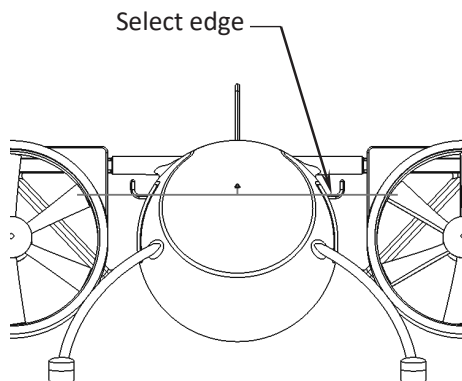

Enter the **Perimeter** of **X** here: _____.

3. Inserting the Model Dimensions:

Select the Top drawing view and click **Model Items** on the **Annotation** tab.

Import dimensions only to the Top drawing view using these options: **Entire Model, Marked for Drawing.**

Click **OK**.

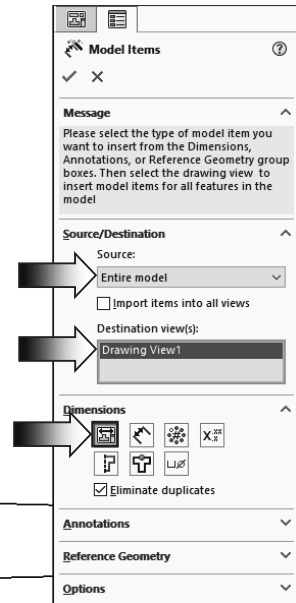
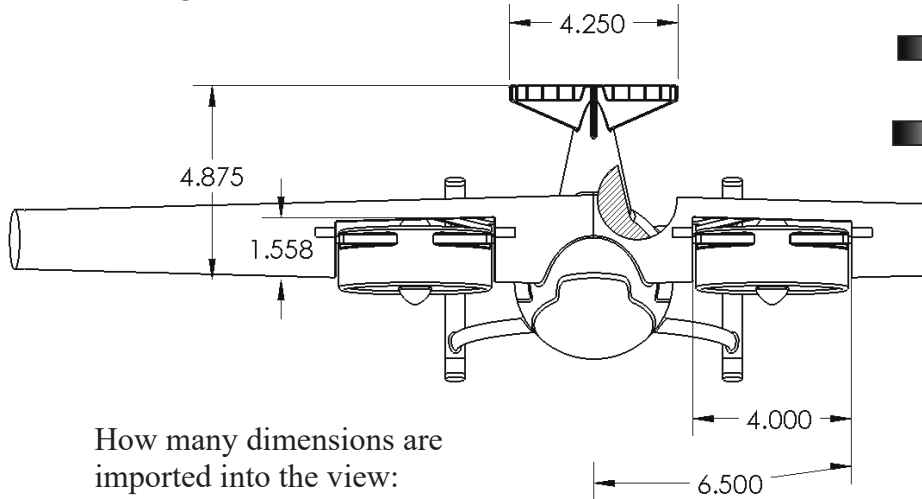

How many dimensions are imported into the view:

- 4 5
 6 7

4. Saving your work:

Select **File, Save As**.

Enter **Challenge_5** for the file name.

Click **Save**.

Summary:

The key features to the Challenge 4 are:

Creating a Broken-Out Section view and Inserting the Model Dimensions.

CHALLENGE 6

This challenge examines your skills on the following:

- * Saving a named view
- * Creating a section view
- * Measuring the perimeter of a surface

1. Opening a part document:

Select **File / Open**.

Browse to the Training Folder and open the part document named:
Block.sldprt.

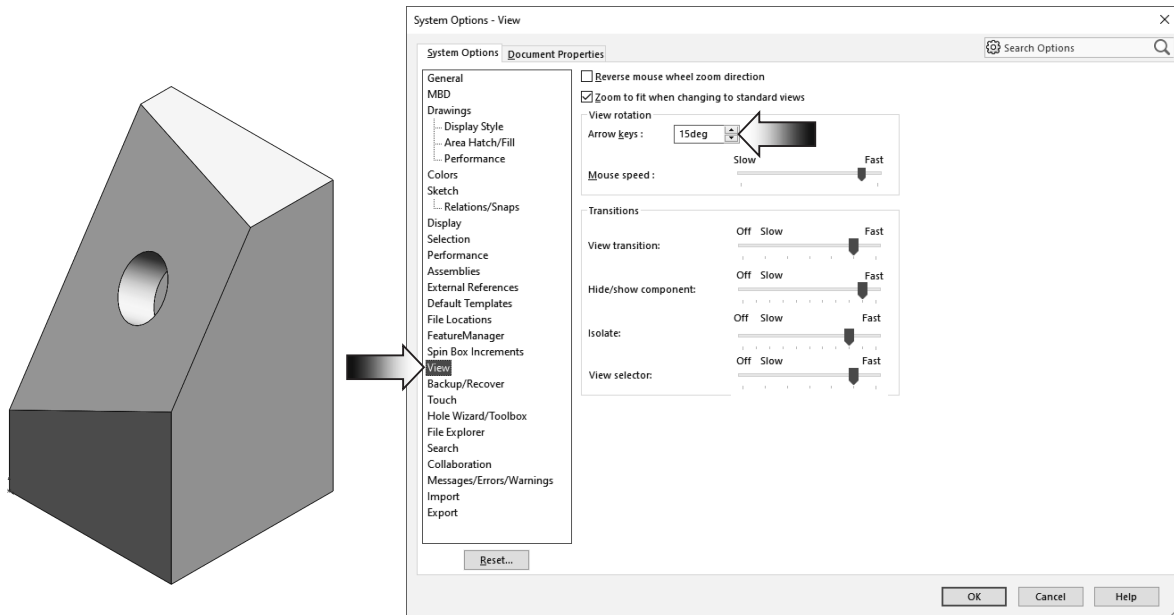

2. Changing the arrow key's angle:

The angle of the Arrow Key needs to change back to its default value for this challenge.

Click **Tools, Options, System Options, View**.

Change the angle of the Arrow Keys to **15deg**, and click **OK**.

3. Changing the view orientation:

Select the face indicated and press **Control+8** to rotate the model Normal to the screen.

Normal To
this face

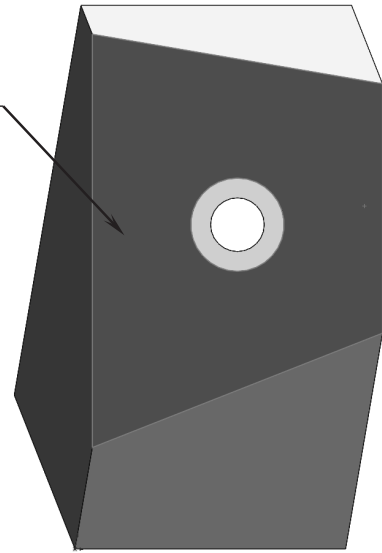

Hold the **Alt** key down and press the **Left Arrow** key 5 times. The new orientation should look similar to the image shown at the bottom right of the page.

Press the **Spacebar** to access the Orientation dialog box.

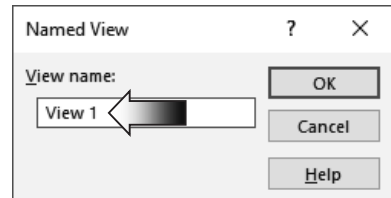
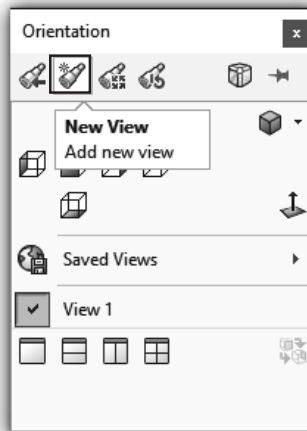

Click the New View button and enter **View 1** to save the new view.

Click **OK**.

The View 1 can now be accessed using the View Palette. (Any drawing view can also be switched to the new View 1 by selecting its checkbox on the Annotation, More Views section.)

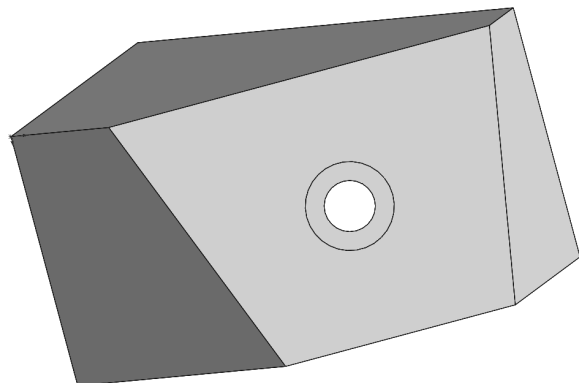

4. Making a drawing:

Right-click the name **Block** and select **Opening Drawing**.

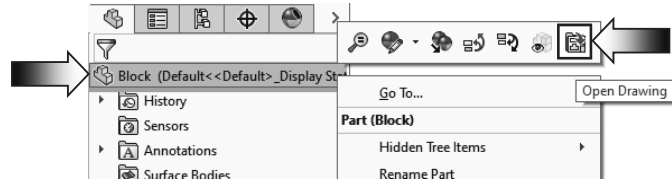

The 4 existing drawing views are for reference only. A couple of new drawing views need to be created.

Drag/drop the **Current View** from the **View Palette** as shown below.

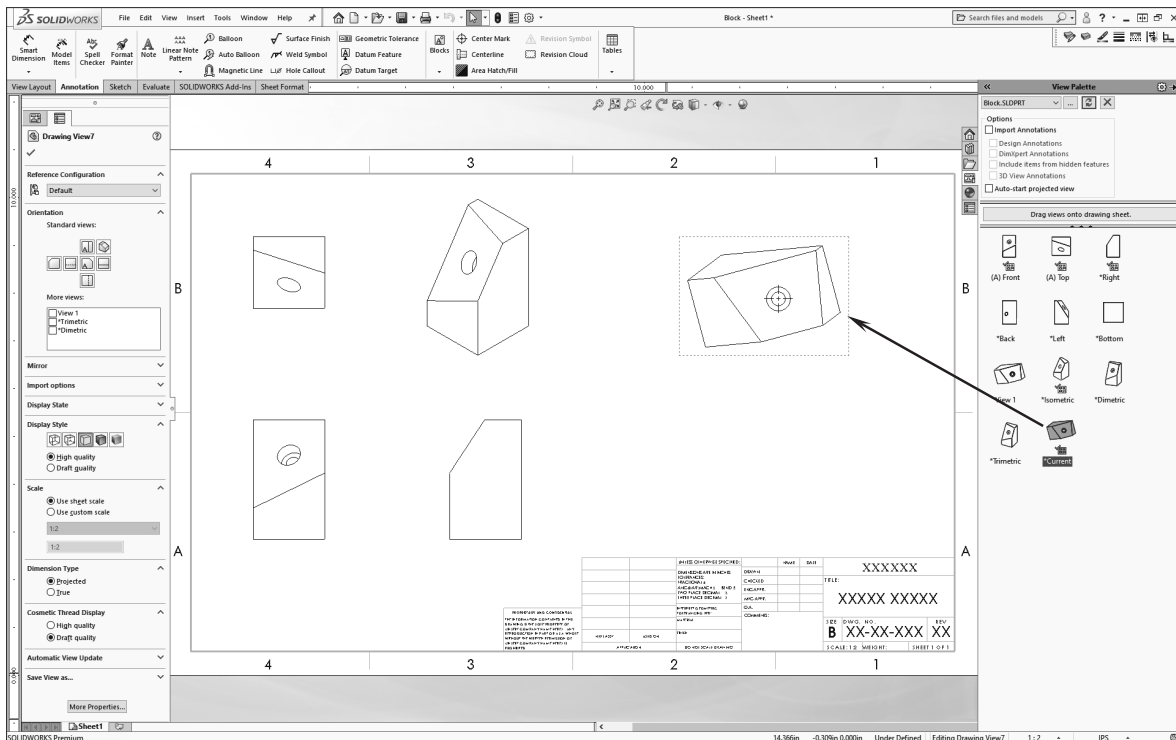
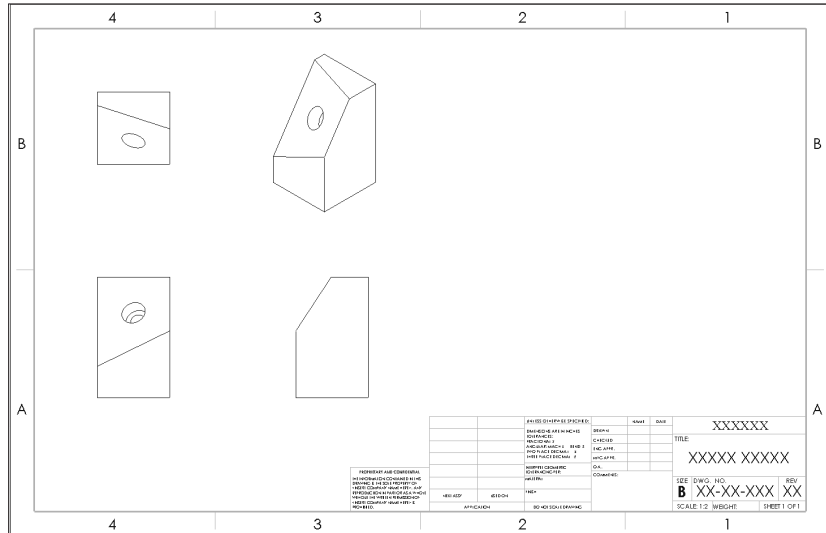

5. Adding a Projection Dimension:

Select the new drawing view and click **Projected** under the Dimension Type section, on the FeatureManager tree.



Add a reference dimension as shown in the image.

Enter the Projected dimension **X**

here _____ in.

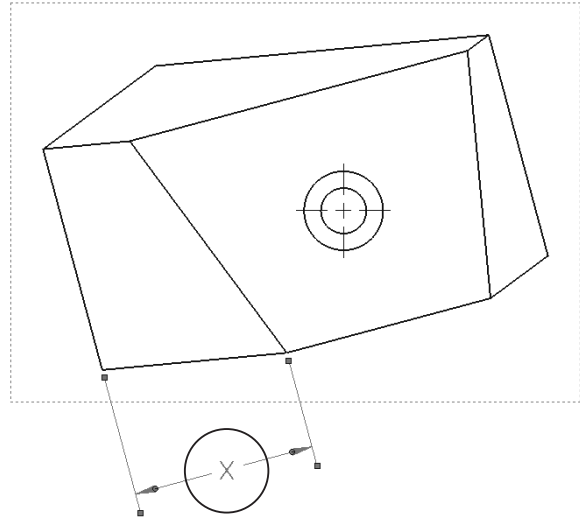

6. Creating a section view:

Switch to the **Sketch** tab and sketch a **Line** similar to the one shown in image below.

Add a **Concentric** relation between the Midpoint of the line and one of the circles.

Add a **Parallel** relation between the line and the edge on the far right side.

Switch to the **View Layout** tab and click **Section View**.

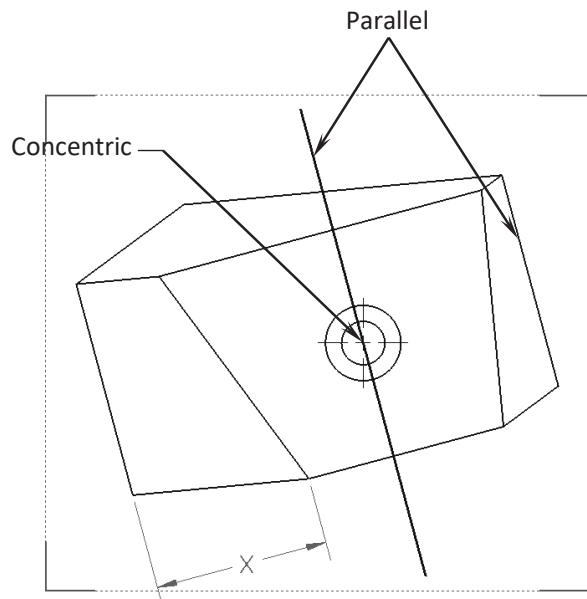

7. Finding the surface Perimeter:

Place the section view on the left side of the main view.

The section arrows should be pointing to the right.

Switch to the **Evaluate** tab and click **Measure**.

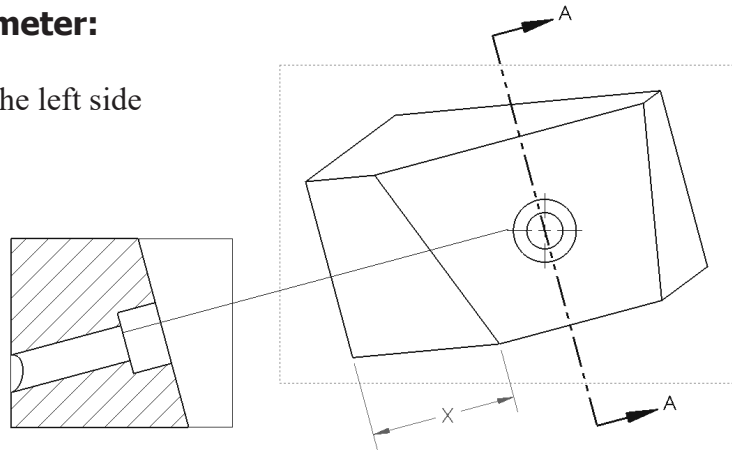

Select this face

Select the face indicated, locate the **Perimeter** value and enter it here:

_____ in.

Area:	3.27879983in ²	2115.35mm ²
Perimeter:	7.5717394in	192.32mm

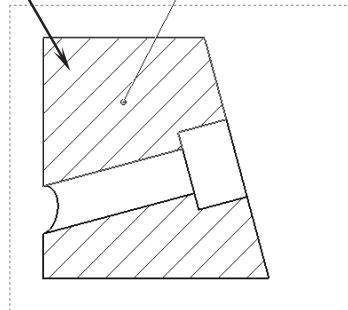

SECTION A-A

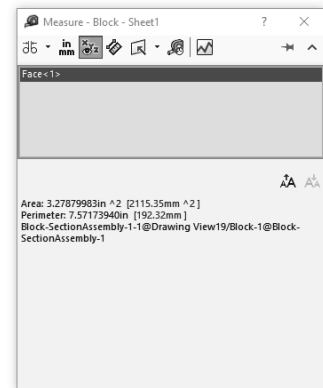

8. Saving your work:

Select **File, Save As**.

Enter **Challenge_6** for the file name.

Click **Save**.

Summary:

The key features to the Challenge 4 are:

Creating a Custom view and making a section from the view for measurements.