

Engineering Graphics Essentials with AutoCAD® 2027 Instruction

Text and Video Instruction

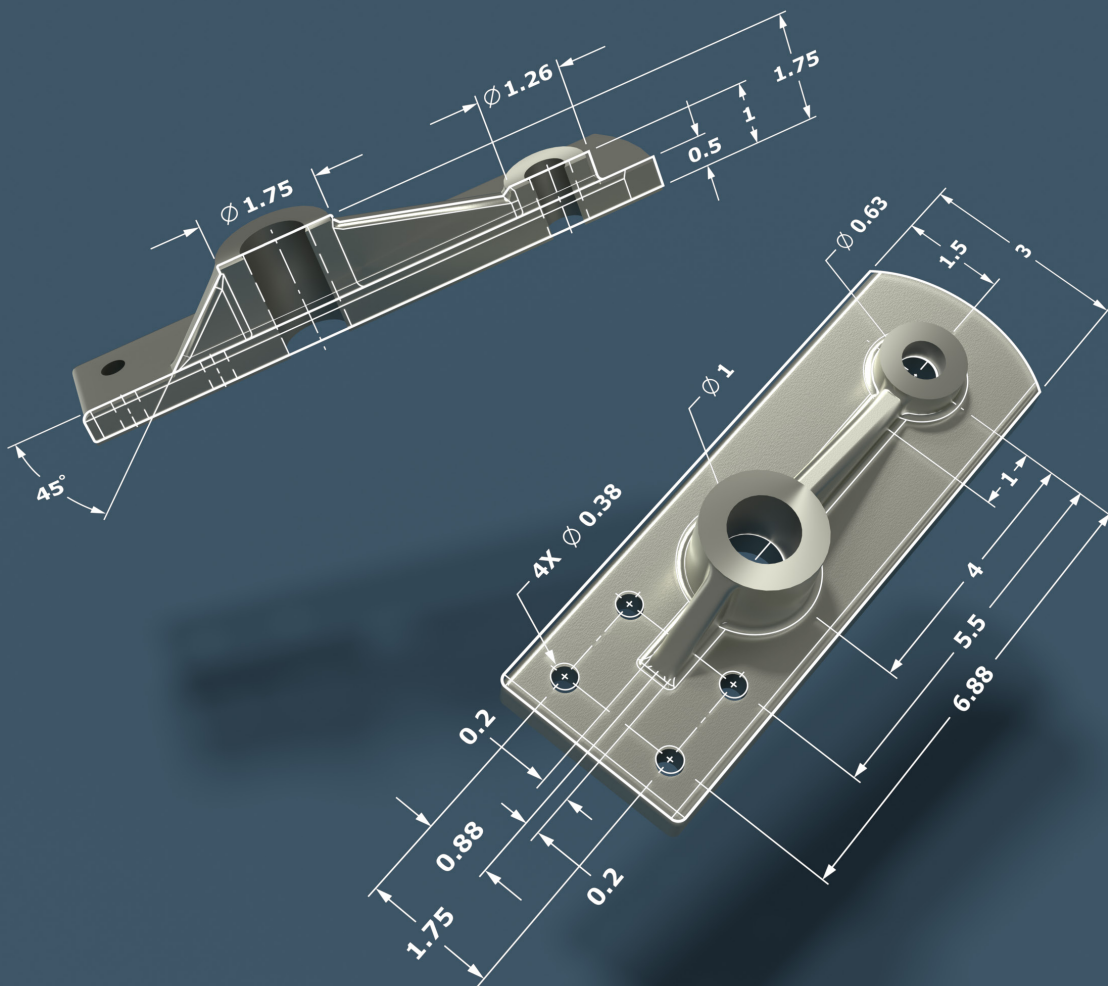

Kirstie Plantenberg
Summer Rayess

Visit the following websites to learn more about this book:



[amazon.com](https://www.amazon.com)

[Google books](https://books.google.com)

[BARNES & NOBLE](https://www.barnesandnoble.com)

CHAPTER 5

CREATING ORTHOGRAPHIC PROJECTIONS IN AUTOCAD®

CHAPTER OUTLINE

5.1) INTRODUCTION	2
5.2) LAYERS	2
5.2.1) The Layers panel	5
5.2.2) Layer properties	7
5.3) LINE TYPE SCALE	10
5.4) PROPERTIES	10
5.4.1) The Properties panel	11
5.5) PRINTING USING PEN WIDTHS	12
5.6) CREATING LAYERS TUTORIAL	13
5.6.1) Setting drawing parameters	13
5.6.2) Creating layers	13
5.6.3) Drawing on different layers	15
5.6.4) Line type scale	16
5.7) BLOCKING	17
5.8) MODEL AND LAYOUT SPACE	21
5.8.1) Model space	21
5.8.2) Layout space	21
5.9) CENTERLINES	23
5.10) TITLE BLOCK TUTORIAL	25
5.10.1) Blocking a title block	25
5.10.2) Blocking a metric title block	27
5.11) ORTHOGRAPHIC PROJECTION TUTORIAL	30
5.11.1) Draw the front view	30
5.11.2) Drawing the right side view	31
5.11.3) Drawing the top view	35
5.11.4) Drawing centerlines	37
5.11.5) Printing the layout	39
5.11.6) Printing a metric drawing	47
ORTHOGRAPHIC PROJECTIONS IN AUTOCAD® QUESTIONS	50
ORTHOGRAPHIC PROJECTIONS IN AUTOCAD® PROBLEMS	55

CHAPTER SUMMARY

In this chapter you will learn how to draw an orthographic projection in AutoCAD®. Layers will be used which allow a drawing to contain different line types and to print using different line widths. You will draw a title block and border that can be repeatedly used. By the end of this chapter, you will be able to create a technically correct orthographic projection using proper line types and weights.

5.1) INTRODUCTION

An orthographic projection is a 2-D representation of a 3-D part. The line types and line weights used to create the orthographic projection give valuable information to the drawing or print reader. AutoCAD® enables you to draw orthographic projections using different line types and to print drawings using different line weights. This is accomplished by using layers.

5.2) LAYERS

Layers are like transparencies, one placed over the top of another. Each transparency/layer contains a different line type or a different part of the drawing. One layer may be used to create visible lines, while another layer may be used to create hidden lines. One layer may draw objects in red while another layer may draw objects in blue and so on. Assigning a different line type and color to each layer helps you control and organize the drawing. Before beginning to draw, many layers will be created, and their properties assigned. While drawing, the current or active layer (the layer you are drawing on) will be switched from one to another depending on what feature of the drawing you are working on.

Figure 5.2-1 shows an orthographic projection that uses different line types and line weights. The line type for each layer is set directly as a layer property. The line thickness is controlled by the color in which it is drawn. Figure 5.2-2 shows a possible layer organization scheme that could be used to create the orthographic projection shown in Figure 5.2-2.

Layers not only facilitate the use of line types and weights, but they can also help you visualize, create, and edit your work. For example, layers can be turned on or off. This is very useful when using a projection/construction line. Construction lines are helpful in the creation of an orthographic projection. However, they are not part of the final drawing. It would be tedious if you had to erase all the construction lines individually. A better way is to create a separate *Construction* layer and just turn it off (make it invisible) when they are no longer needed. Layers can also be locked. This means that you can see the layer, but you cannot select any of the objects on the layer. This is very useful when your drawing is very complex, and you need to isolate objects that are on a particular layer.

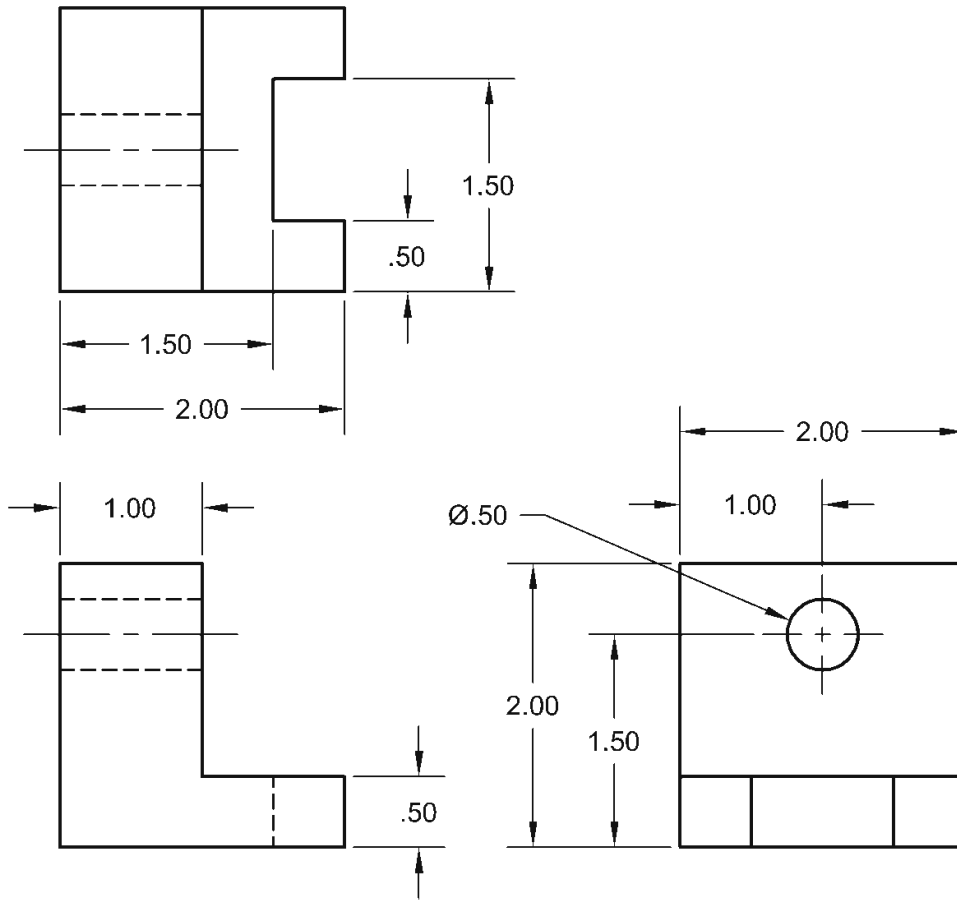

Figure 5.2-1: A typical orthographic projection

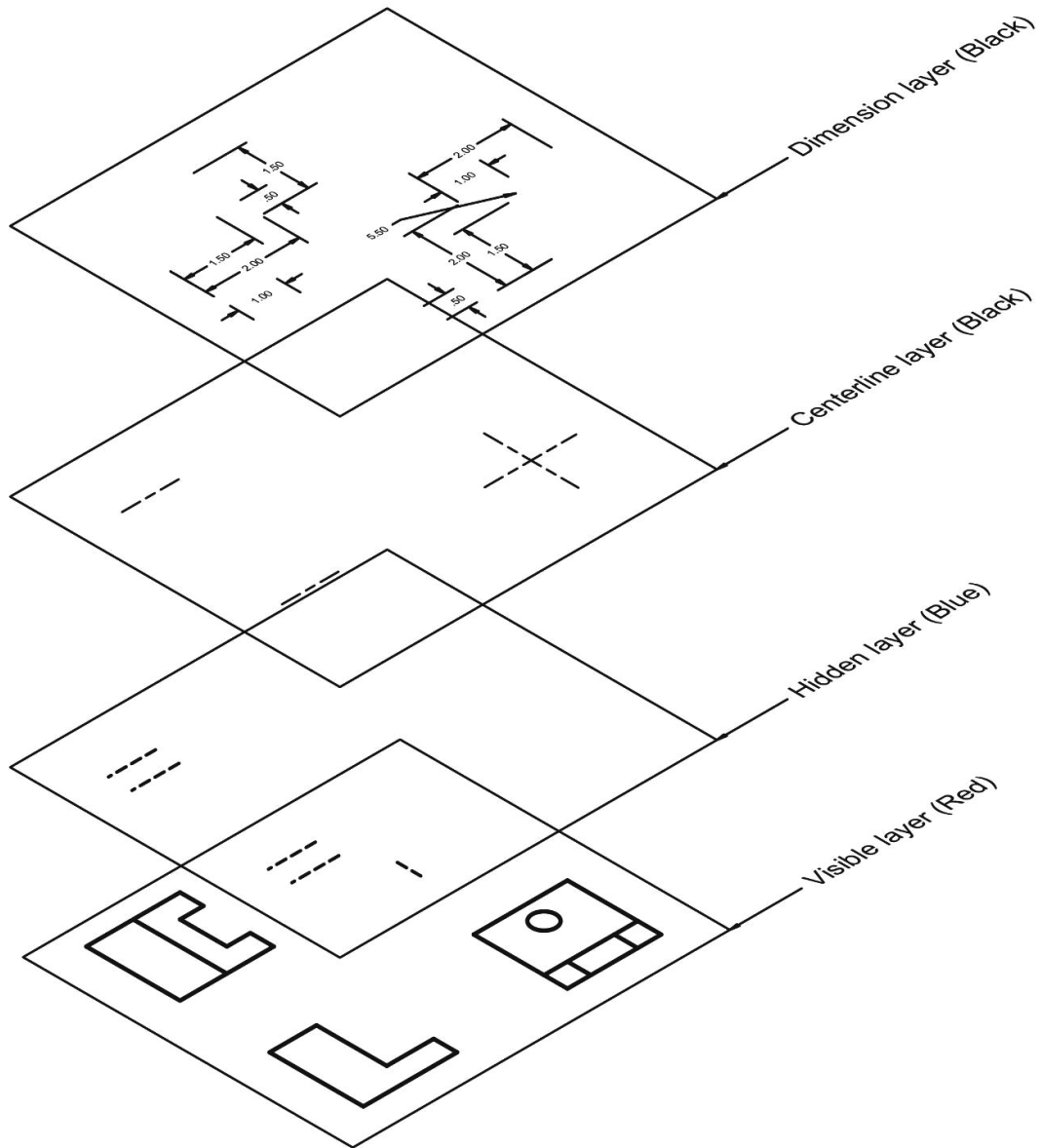

Figure 5.2-2: Layer organization of an orthographic projection

5.2.1) The *Layers* panel

The *Layers* panel is shown in Figures 5.2-3. The most frequently used commands/areas in the *Layers* panel are the *Layers Properties Manager* icon and the *Layers pull-down selection* menu. The *Layers Properties Manager* is used to create, name, assign line types and manage layers. The *Layers* menu allows you to quickly switch from one layer to the next and turn layers on and off.

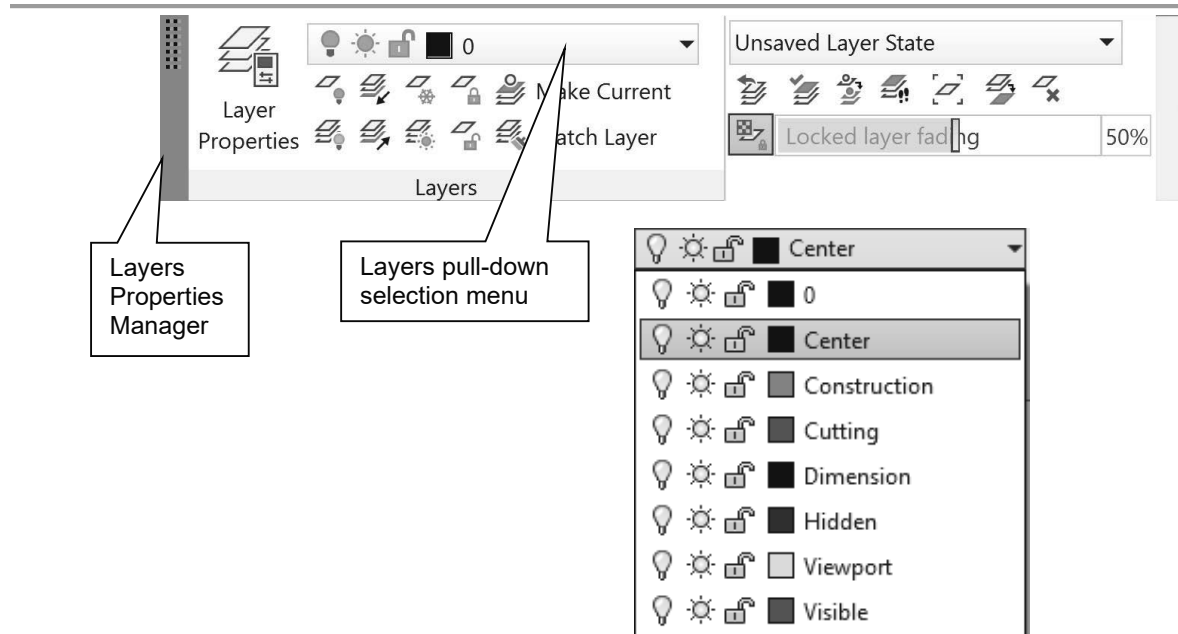
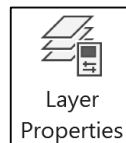



Figure 5.2-3: The *Layers* panel





















The icons/features of the *Layers* panel are:



- Layers Properties Manager window: This icon brings up a *Layers Properties Manager* window. This window is the place where layers are created, and the layer properties are assigned.
- Layer pull-down selection window: This pull-down window shows all of the available layers, allows you to switch between layers and enables you to change an object from one layer to another. To the left of each layer name is a set of quick access layer status settings that may be turned on or off. To turn these settings on and off, just click on them. Reading from left to right these settings are:

- On/Off:  The ON/OFF status of a layer is indicated by the light bulb. If it is yellow, the layer is ON and the objects on this layer can be seen. If it is gray, the layer is OFF and the objects on this layer cannot be seen.
- Freeze/Thaw:  The FREEZE/THAW status of a layer is indicated by two suns. The big yellow sun freezes/thaws all viewports and the small sun freezes/thaws only the current

viewport. If a layer is FROZEN, the sun will turn into a snowflake. Objects on a frozen layer are not displayed, regenerated, or plotted. Freezing layers shortens regenerating time.

- Lock/Unlock:  The LOCK/UNLOCK status of a layer is indicated by the pad lock. If the lock is open, the layer is UNLOCKED. The objects on this layer can be seen and selected. If the lock is closed, the layer is LOCKED. The objects on this layer can be seen but not selected.
- Layer States menu:  This is where you can save the current settings for layers in a named layer state and then restore those settings later.
- Layer Isolate:  This command locks all layers except the one you choose to isolate.
- Layer Unisolate:  This command unlocks all the layers that were locked while using the *Layer Isolate* command.
- Freeze:  Freezes a selected object's layer.
- Off:  Turns a selected object's layer off.
- Make Object's Layer Current:  This icon sets the layer of a selected object to be the current one.
- Match:  Matches the layer of a selected object to a destination layer.
- Layer Previous:  This icon switches you back to your previous layer.
- Turn All Layers On:  Turns all the drawing layers on.
- Thaw All Layers:  Thaws all the drawing layers.
- Lock:  Locks a selected object's layer.
- Unlock:  Unlocks a selected object's layer.
- Change to Current Layer:  Changes the layer of a selected object to the current one.
- Copy Objects to New Layer:  Creates duplicates of the selected objects on a specified layer.
- Layer Walks:  Allows you to see all the objects on an individual layer while hiding the objects on the other layers.
- Isolate to Current Viewport:  Freezes select layers in all viewports except the current viewport.
- Merge:  Merges selected layers into a target layer.
- Delete:  Deletes all objects on a selected layer and then purges the layer.
- Locked Layer Fading:  The locked layer fading may be set using this slider bar.

5.2.2) Layer properties

The *Layer Properties Manager* window is the place where you can create layers and set their properties. This window may be accessed using the command **LAYER** or by clicking on the

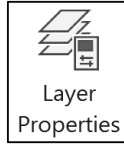

Layer Properties Manager icon in the *Layers* panel. Figure 5.2-4 shows the *Layer Properties Manager* window with the important features identified. Most of the features are self-explanatory except for the layer filter. The *New Property Filter* window is a place where you may create filters based on one or more layer properties. Right clicking on any layer name(s) accesses a shortcut menu with several useful commands as shown in Figure 5.2-5.

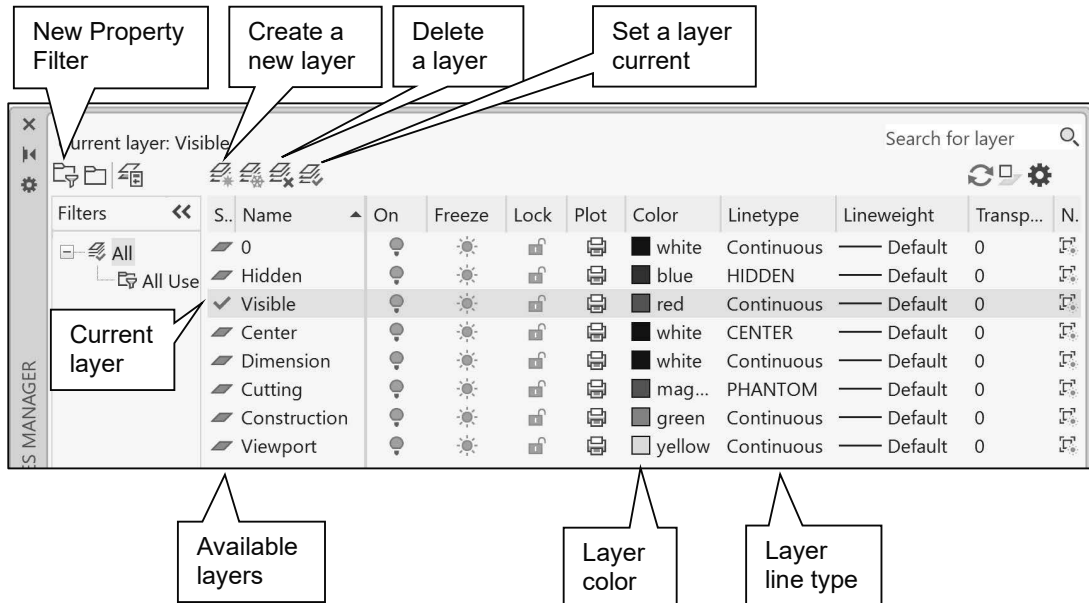

Figure 5.2-4: The *Layer Properties Manager* window

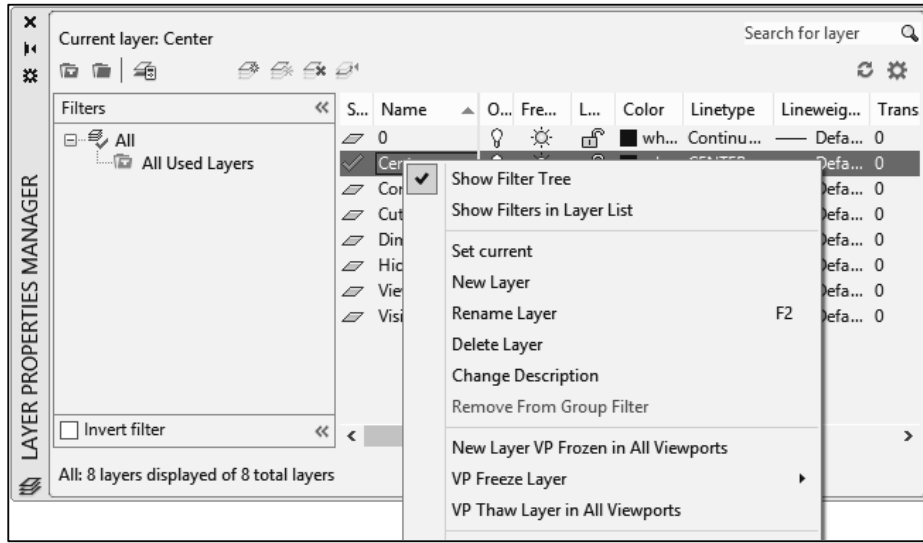
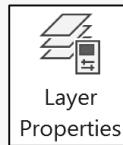

Figure 5.2-5: The *Layer Properties Manager* shortcut menu

Creating a new layer and setting layer properties



- 1) Command: **L**ayer or Layers panel:
- 2) Layer Properties Manager window:

- a) Click on the *New Layer* icon
- b) Name your layer.
- c) Click on the square colored box under the heading *Color*. A *Select Color* window will appear.

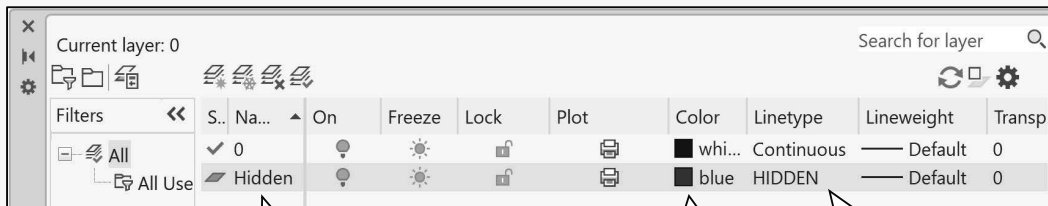

Name layer

Click to change layer color

Click to change layer linetype

- 3) Select Color window – Index Color tab:
 - a) Select a color for your layer. It is best to select a standard color. Note: The color *White* and *Black* are the same.
 - b) **OK**

Standard colors

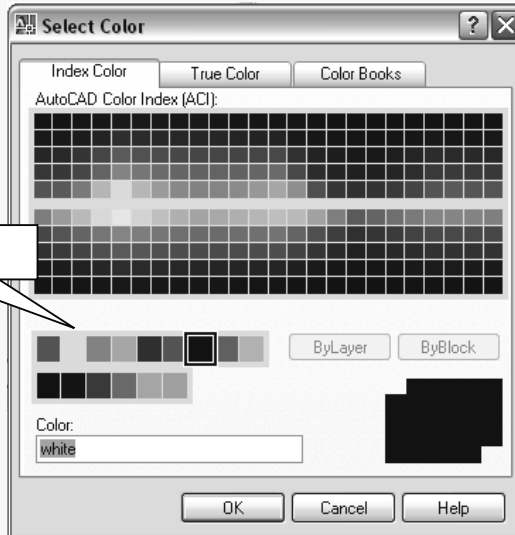

- 4) Layer Properties Manager window: Click on the name of the line type under the heading *Linetype*. A *Select Linetype* window will appear.
- 5) Select Linetype window: If the line type that you wish to use is not *Continuous*, click on **Load...** to select a different line type. A *Load or Reload Linetypes* window will appear.

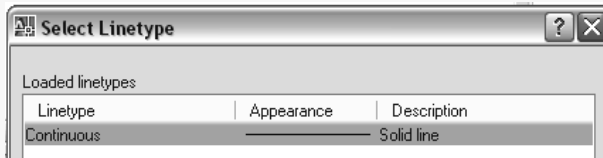

- 6) Load or Reload Linetypes window:
 - a) Scroll down until you find the desired line type and select it.
 - b) **OK**

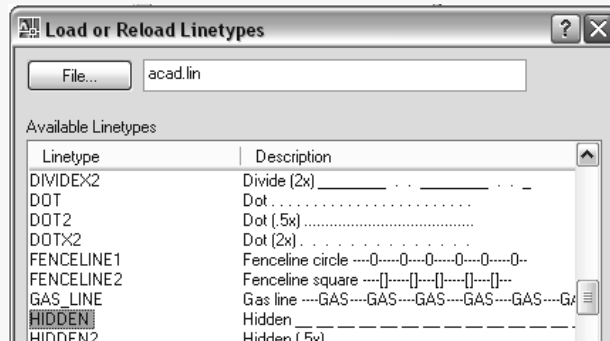

- 7) Select Linetype window:
 - a) Select the line type that you wish to assign to the layer.
 - b) **OK**.

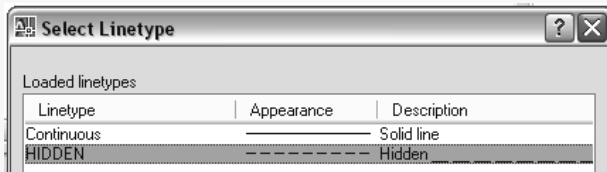

- 8) Layer Properties Manager window: Close the window.

5.3) LINE TYPE SCALE

Line type scale only applies to lines that break, such as hidden lines, centerlines and phantom lines. The line type scale determines the size of the dashes and the size of the spaces between dashes or dots. You can control the line type scale either globally (for all lines) or individually for each object. By default, both global and individual line type scales are set to 1.00. The smaller the line type scale, the smaller the dashes and spaces. The line type scale is adjusted according to your drawing size and the distance that a line traverses. A short line segment that does not break and is displayed as continuous will need to have a smaller line type scale. Figure 5.3-1 shows a centerline at three different line type scales. The global line type scale may be set using the **LTSCALE** command.

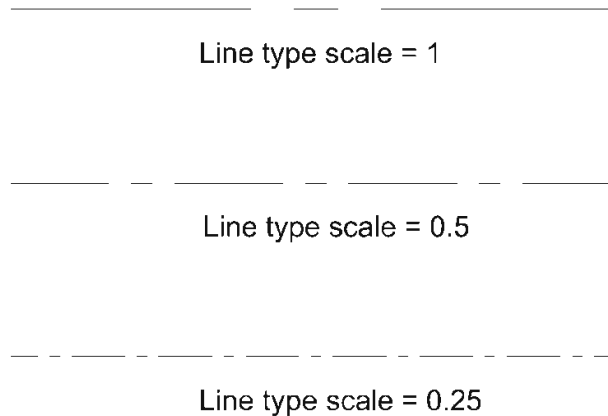

Figure 5.3-1: The effects of line type scale

5.4) PROPERTIES

The properties of an individual object may be changed by selecting the object and then



selecting the *Properties* icon in the *View* tab - *Palettes* panel. Figure 5.4-1 shows the *Properties* window of a circle. Several properties such as object layer, line type scale, and radius or diameter may be changed. Different objects will have different options available in the *Properties* window. Properties may also be changed using the **CHPROP** command.

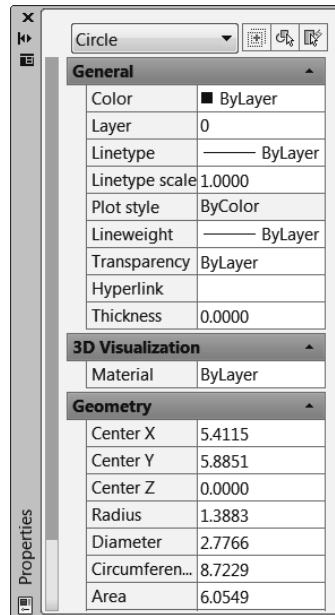
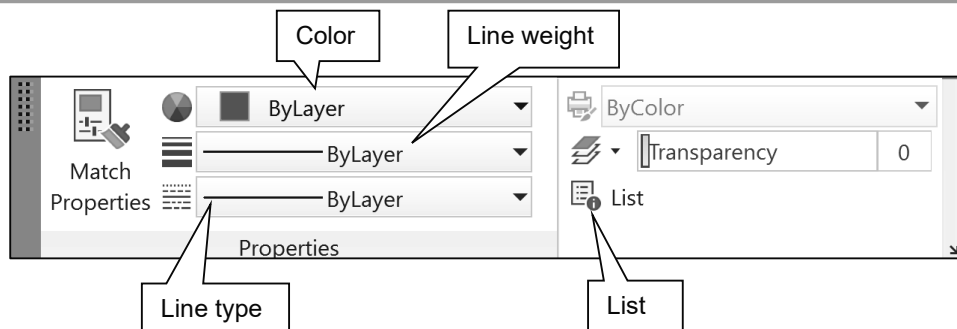

Figure 5.4-1: Properties window for a circle

5.4.1) The *Properties* panel

The *Properties* panel (Figure 5.4-2) is located in the *Home* tab. It allows you to change the color, line type and line weight of a selected object. It is my suggestion that these properties always remain on ByLayer (the default properties of the object's layer). If you need to change one of these properties, your first action should be to move the object to a layer that has those properties. This creates a much more organized drawing. Changing the ByLayer settings in the properties toolbar should be reserved for occasional use only. Two useful commands found in the *Properties* panel are *Match Properties* and *List*. The **LIST** command lists the property data for a selected object.

Figure 5.4-2: The *Properties* panel

5.5) PRINTING USING PEN WIDTHS

The color of an object dictates the printed thickness of that object. This is why we will specify a different color to each line type/layer. The pen widths are stored in files that are computer specific. They are not stored in the drawing file. If you are using a public computer, it is a good idea to check the pen width settings before printing.

You may print in color, grey scale or in black and white. If you are printing to an inkjet and in color, you need to choose colors based on how they look. If you are printing to a laser printer it is best to print in black and white and not in grey scale.

Setting pen widths

- 1) Menu browser: **Print – Page Setup...**
- 2) Page Setup Manager window: **Modify...**
- 3) Page Setup – Model window:

- a) In the *Plot style table (pen assignments)* area, select **monochrome.ctb** from the pull-down menu.
- b) Question window (Assign this plot style table to all layouts?): **Yes**
- c) Select the **Edit...**  icon next to the pull-down menu.

- 4) Plot Style Table Editor – monochrome.ctb window:

- a) Plot styles field: Select a color
- b) Lineweight field: Select the appropriate line weight using the pull-down menu.
- c) Repeat for all colors that you are using. Note that the print color in the *Properties* area is always **Black** no matter what the *Plot styles* color is.
- d) **Save & Close**

- 5) Page Setup – Model window: **OK**
- 6) Page Setup Manager window: **Close**

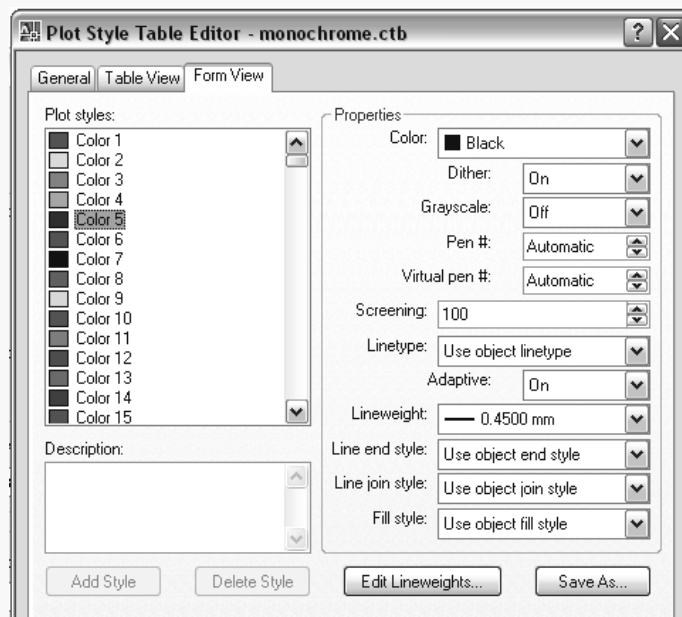
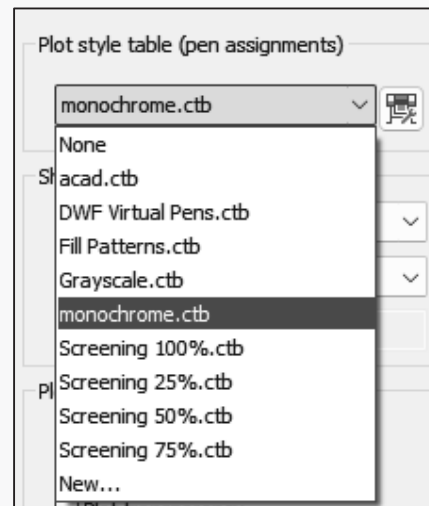

5.6) CREATING LAYERS TUTORIAL

The objective of this tutorial is to create a set of standard layers that will be used to create orthographic projections. These layers will be saved to a template file so that they can be used repeatedly.

5.6.1) Setting drawing parameters

- 1) View the *Layers & Penwidths* video and read sections 5.1) through 5.5).
- 2) Open your **set-inch.dwt**. Your *set-inch* template file should have the following settings. If it does not, change them at this point.
 - **UNITS**
 - a. Units = inches
 - b. Precision = 0.00
 - **LIMITS** = 11,8.5
 - **STyle**
 - a. Text font = Arial
 - b. Text height = 0.12
 - c. Make sure the **Annotative** toggle is checked.
- 3) Set the global line type scale to 0.5.
 - a) Command: **Itscale**
 - b) Enter new linetype scale factor <1.0000>: **0.5**

5.6.2) Creating layers

- 1) Command: **la** or Layers panel:
- 2) Layer Properties Manager window:

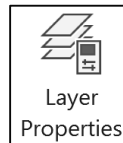

- a) Click on the *New Layer* icon 

b) Name your layer **Hidden**.

c) Click on the square colored box under the heading *Color* that is associated with the *Hidden* layer. A *Select Color* window will appear.

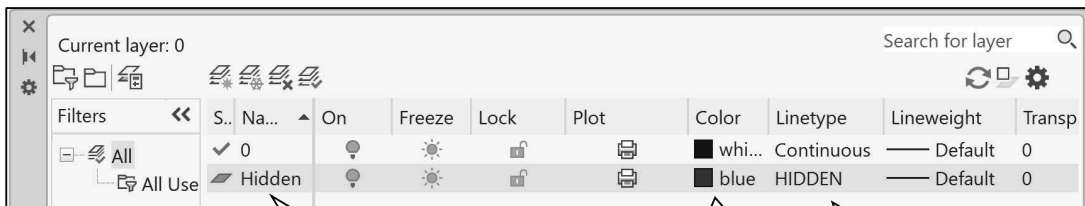

Name layer

Click to change layer color

Click to change layer linetype

- 3) Select Color window – Index Color tab:
 - a) Select the color **Blue** from the standard colors bar.
 - b) **OK**

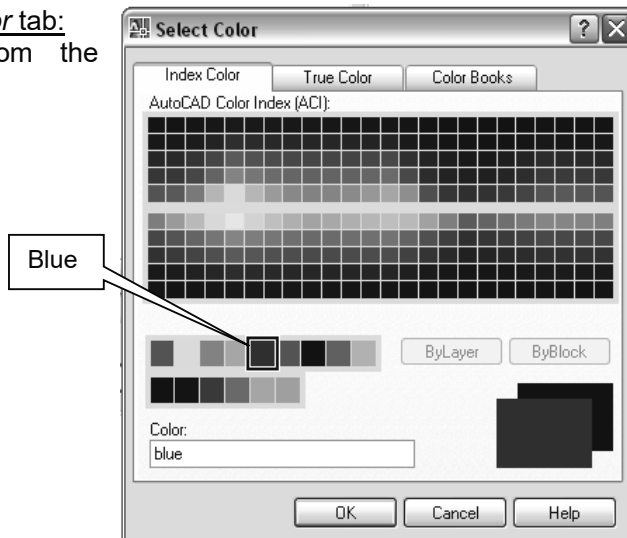

- 4) Layer Properties Manager window: Click on the name of the line type under the heading *Linetype* that is associated with the *Hidden* layer. A *Select Linetype* window will appear.

- 5) Select Linetype window: Click on **Load...** A *Load or Reload Linetypes* window will appear.

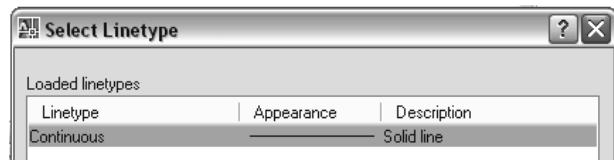

- 6) Load or Reload Linetypes window:
 - a) Scroll down until you find the **HIDDEN** line type and select it.
 - b) **OK**

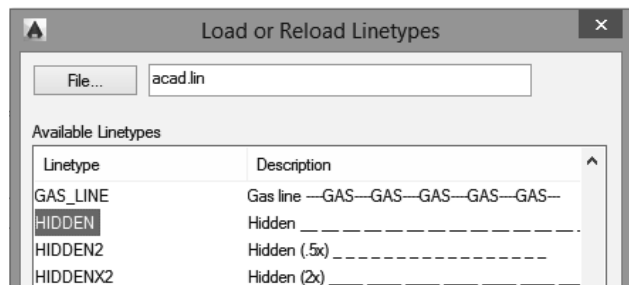

- 7) Select Linetype window:
 - a) Select the **HIDDEN** line type.
 - b) **OK.**

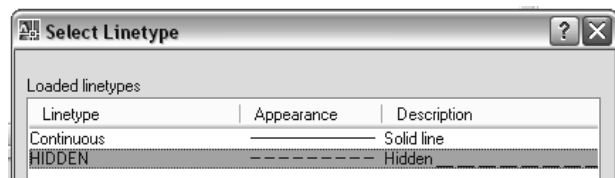

- 8) In a similar fashion, create the following layers.
- **Visible**, color = **red**, linetype = **Continuous**
 - **Center**, color = **white/black**, linetype = **CENTER**
 - **Dimension**, color = **white/black**, linetype = **Continuous**
 - **Cutting**, color = **magenta**, linetype = **PHANTOM**
 - **Construction**, color = **green**, linetype = **Continuous**
 - **Viewport**, color = **yellow**, linetype = **Continuous**

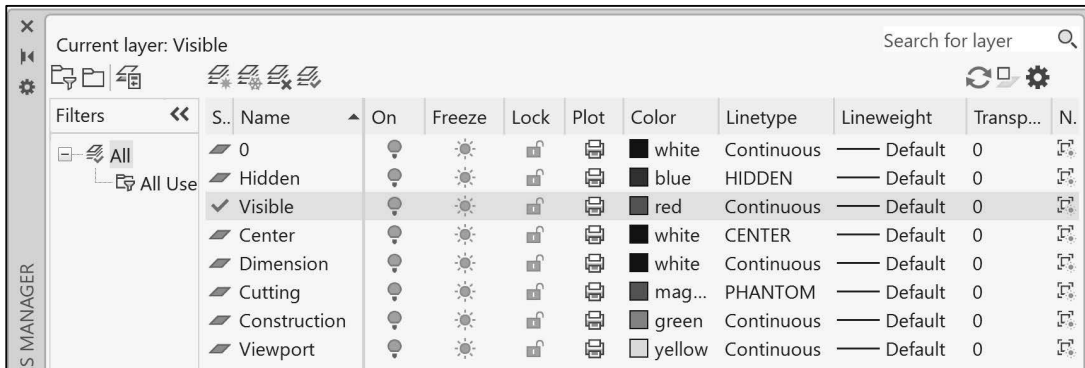

- 9)  **set-inch.dwg.**

5.6.3) Drawing on different layers

- 1)  **Layers Tut.dwg.**

- 2) Draw a line on each layer to see if the layer properties were set correctly.
- a) Set the **Visible** layer to be current.
 - i. Layers panel: Expand the *Layer pull-down* menu and select **Visible**.
 - b) Draw a **Line**. It should be red.
 - c) Set the **Hidden** layer to be current and draw 2 **Lines**. They should be blue and dashed.
 - d) Repeat for all the other layers.

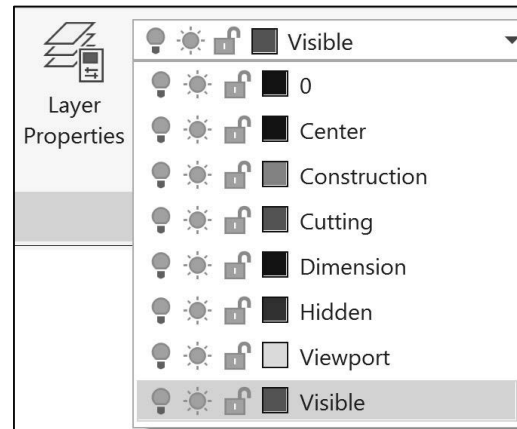

5.6.4) Line type scale

- 1) Change the global line type scale (**LTSCALE**) to **0.25**. Notice that the dashes and spaces between the dashes become smaller.

How?

- a) Command: **ltscale**
- b) Enter new linetype scale factor <0.5000>: **0.25**

- 2) Change your **LTSCALE** to **1**.
- 3) Change your **LTSCALE** back to **0.5**.
- 4) Change the line type scale of one of the hidden lines.
 - a) Select one of the hidden lines.



- b) View tab - Palettes panel:
- c) Properties window: Change the *Linetype scale* to **2**.

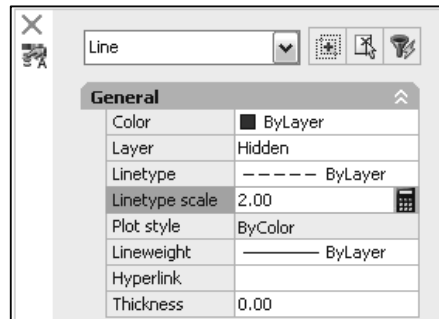

- 5) **Save** and **print** your drawing.

Exercise 5.6-1: Creating layers

Open your **set-mm.dwt**, make sure that it has the following settings and create the layers indicated. Then, resave your template file.

Settings:

- **UNITS** (Millimeters, Precision = 0)
- **LIMITS** = 297,210
- **STyle** (Text font = Arial, Text height = 3, Annotative)
- **LTSCALE** = 0.5

Layers:

- **Visible**, color = **red**, linetype = **Continuous**
- **Hidden**, color = **blue**, linetype = **HIDDEN**
- **Center**, color = **white/black**, linetype = **CENTER**
- **Dimension**, color = **white/black**, linetype = **Continuous**
- **Cutting**, color = **magenta**, linetype = **PHANTOM**
- **Construction**, color = **green**, linetype = **Continuous**
- **Viewport**, color = **yellow**, linetype = **Continuous**

5.7) BLOCKING

Blocks are a grouping of objects that can be used repeatedly. The command **BLOCK** allows you to define a particular drawing as an entity. It groups all the lines, circles, and other geometric shapes into one entity. This means that you can insert this group into a drawing without having to redraw it. The commands that are relevant for creating and using blocks are grouped in the *Block* panel shown in Figure 5.7-1.

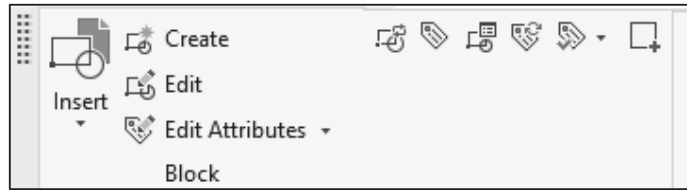





Figure 5.7-1: *Block* panel

The commands contained in the *Block* panel and the other commands related to blocking are:

- **INSERT:**  The INSERT command allows you to retrieve an existing block or wblock.
- **BLOCK:**  The BLOCK command allows you to create a grouping of objects that can be used repeatedly in the current drawing. Blocks are inserted as entities, which means that they can't be edited by erasing parts of them or breaking lines within them unless you use the BEDIT command or EXPLODE the block first.
- **BEDIT:**  The block edit command allows you to select and edit an existing block. The block edit command temporarily adds a *Block Editor* tab to the ribbon as shown in Figure 5.7-2.

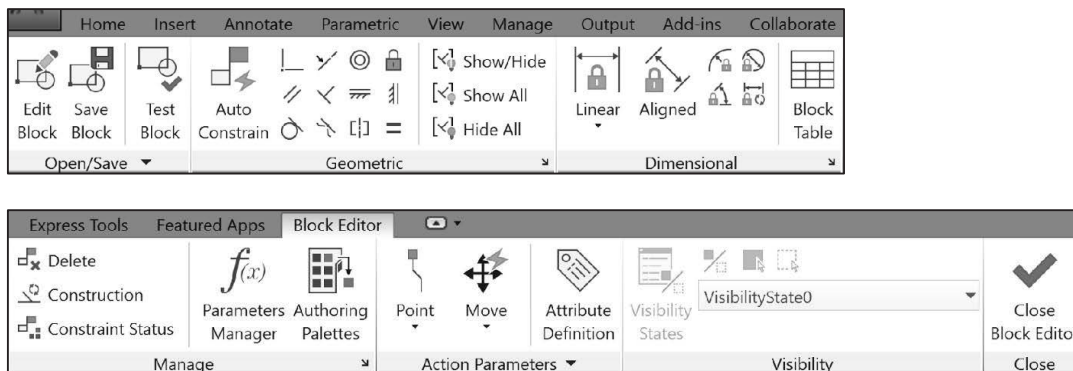





Figure 5.7-2: *Block Editor* tab

- **WBLOCK:** This command writes a block to a file. This allows you to use the block in all drawings not just the current one.
- **EXPLODE:**  Allows you to separate a block into its individual parts. The EXPLODE command may be accessed in the *Modify* panel.
- **BASE (Set Base point):**  Set the insertion base point for the current drawing. The base point is the reference point used when creating and inserting your block. This point should not be arbitrary. It should have some relationship with the block and with the object or space in which it will be inserted.

Creating blocks

- 1) **Command:** **block** or **Block panel:** 
- 2) **Block Definition window:**
 - a) Name the block.
 - b) **Base point area:** Pick a base point/insertion point. This can be accomplished by directly entering a coordinate or by selecting the **Pick point** icon.
 - c) **Objects area:**
 - i. Select all objects that you wish to include in the block definition using the **Select objects** icon. (The objects may also be selected before entering the BLOCK command.)
 - ii. Activate either the **Retain** (keeps the original object as is), **Convert to block** (converts the original object to a block) or **Delete** (deletes the original object) radio button.
 - d) **Behavior area:** Activate **Allow exploding** and **Annotative** checkboxes.
 - e) If necessary, set the **Block units**.
 - f) **OK**

Note: A block is defined within the current drawing and cannot be used in other drawings unless a WBLOCK is created.

Block Definition

Name: Title Block A

Base point

Specify On-screen

 Pick point



X: 0.00

Y: 0.00

Z: 0.00

Objects

Specify On-screen

 Select objects 

Retain

Convert to block

Delete

147 objects selected

Behavior

Annotative

Match block orientation to layout

Scale uniformly

Allow exploding

Settings

Block unit: Inches

Hyperlink...

Description

Open in block editor

OK Cancel Help

Creating a wblock

- 1) Command: **wblock**
- 2) Write Block window:
 - a) Select the **Block** radio button.
 - b) Select the block you wish to write to a file in the pull-down menu.
 - c) Select a location for the file by clicking on the file path icon .
 - d) Select the *Insert units*.
 - e) **OK**

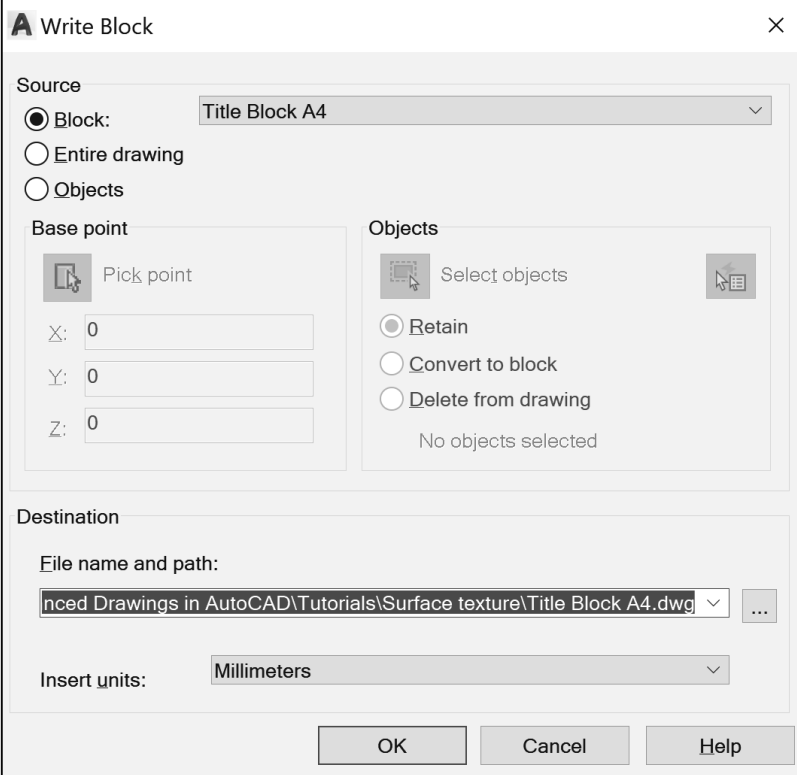

Write Block [X]

Source



Block: Title Block A4 [v]
 Entire drawing
 Objects

Base point

 Pick point

X: 0
Y: 0
Z: 0

Objects

 Select objects 

Retain
 Convert to block
 Delete from drawing

No objects selected

Destination

File name and path:

nced Drawings in AutoCAD\\Tutorials\\Surface texture\\Title Block A4.dwg [v] 

Insert units: Millimeters [v]

OK Cancel Help

Inserting a block or wblock

- 1) **Command:** `insert` or `Block`



panel:

- a) When you select the Insert icon, you will get a dropdown menu that has your drawing block. Select the block you wish to insert and place it in your drawing or select **Blocks from Libraries**.

- b) When you type the command `insert` or select **Recent Blocks...**, **Favorite Blocks...**, or **Blocks from Libraries...** from the above pulldown menu, you will get a *Blocks* window.

Select the block you wish to insert and place it in your drawing. Note that, from this window, you can change the block's scale, rotation, place it repeatedly and explode it.

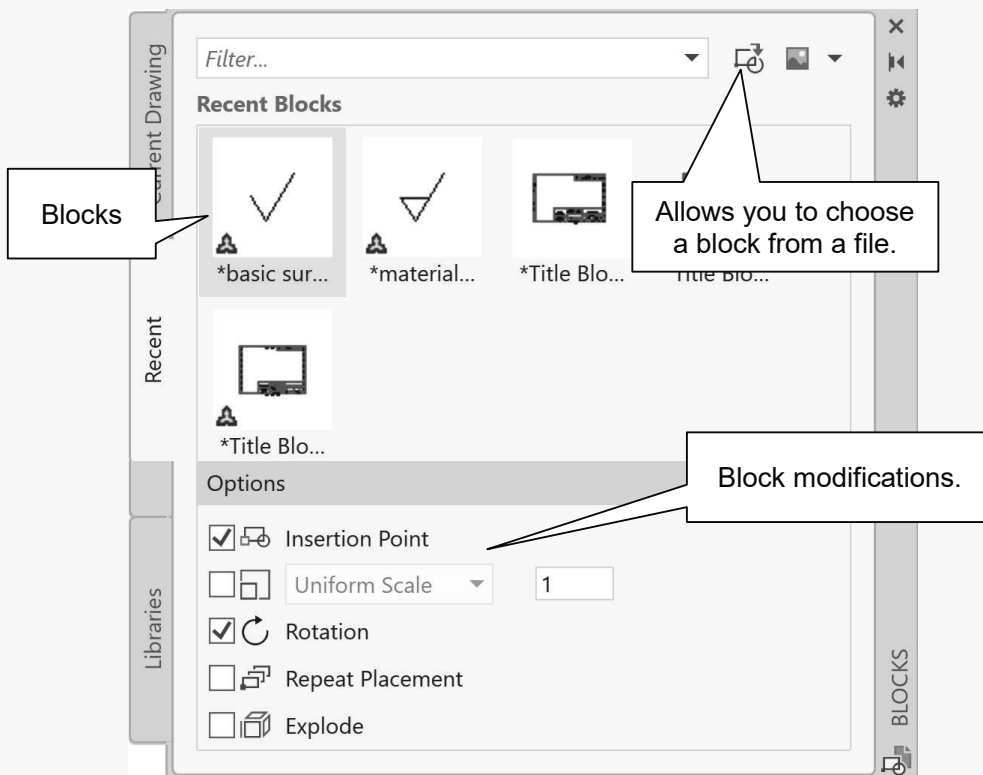
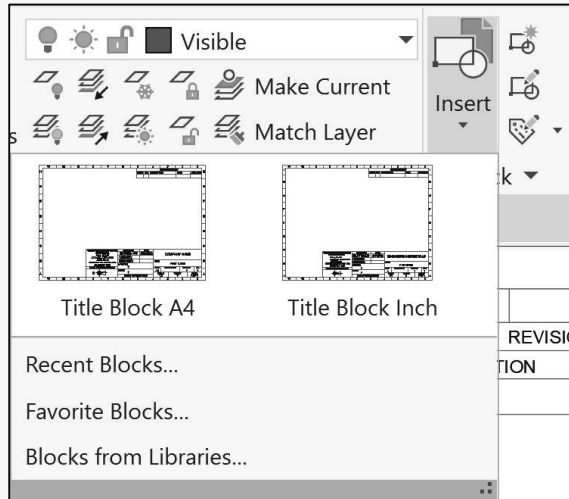

5.8) MODEL AND LAYOUT SPACE

5.8.1) Model space

In model space, you draw your design at a 1:1 scale. You specify whether one unit represents one millimeter, one centimeter, one inch, one foot, or whatever unit is most convenient. If you are going to create a 2-D orthographic projection, you can create both the model (drawing) and annotations (dimensions), and print entirely from within model space. This method is simple but has several limitations including:

- It is suitable for drawings that are viewed from only one direction. 2-D drawings are only viewed from one direction, but 3-D drawings may have many viewing directions.
- It does not support multiple views and view dependent layer settings.
- Scaling the annotations and title block requires computation. This is because if you change the scale of the model the annotations change with it.

With this method, you always draw geometric objects at full scale (1:1) and text, dimension and other annotations at a scale that will appear at the correct size when the drawing is plotted.

5.8.2) Layout space

In paper/layout space, you can place objects and annotations that are not part of your design such as a title block and dimensions. In paper space, you see what will be printed (usually on an 8.5 x 11 sheet of paper). Therefore, objects from the model space that are larger than the paper are scaled to fit the available printing area.

You can plot objects that are in the model space from paper space using viewports. A viewport is a rectangular window that views the object from a specified line of sight. Viewports are most useful when working with a 3-D model. In this situation, you can create several viewports that view the 3-D model from several different vantage points. When looking at a 2-D drawing, you really only want to view the *xy* plane. A situation where you might use multiple viewports with a 2-D drawing is if you are showing part of the model at a different scale. The command VIEWPORTS may be used to create additional viewports.

In paper space, each layout viewport is like a picture frame containing a photograph of the model. Each layout viewport contains a view that displays the model at an independent scale and orientation that you specify. You can also specify different layers properties in each layout viewport. The advantages of plotting from paper space are:

- You can plot multiple viewports.
- The size and location of the objects within each viewport is completely within your control.
- With annotative scaling, it is not necessary to calculate the appropriate dimension and text scale. Annotative scaling will be discussed in detail in the “*Dimensioning in AutoCAD®*” chapter. Figure 5.8-1 shows an example of what you would see in paper space before plotting.

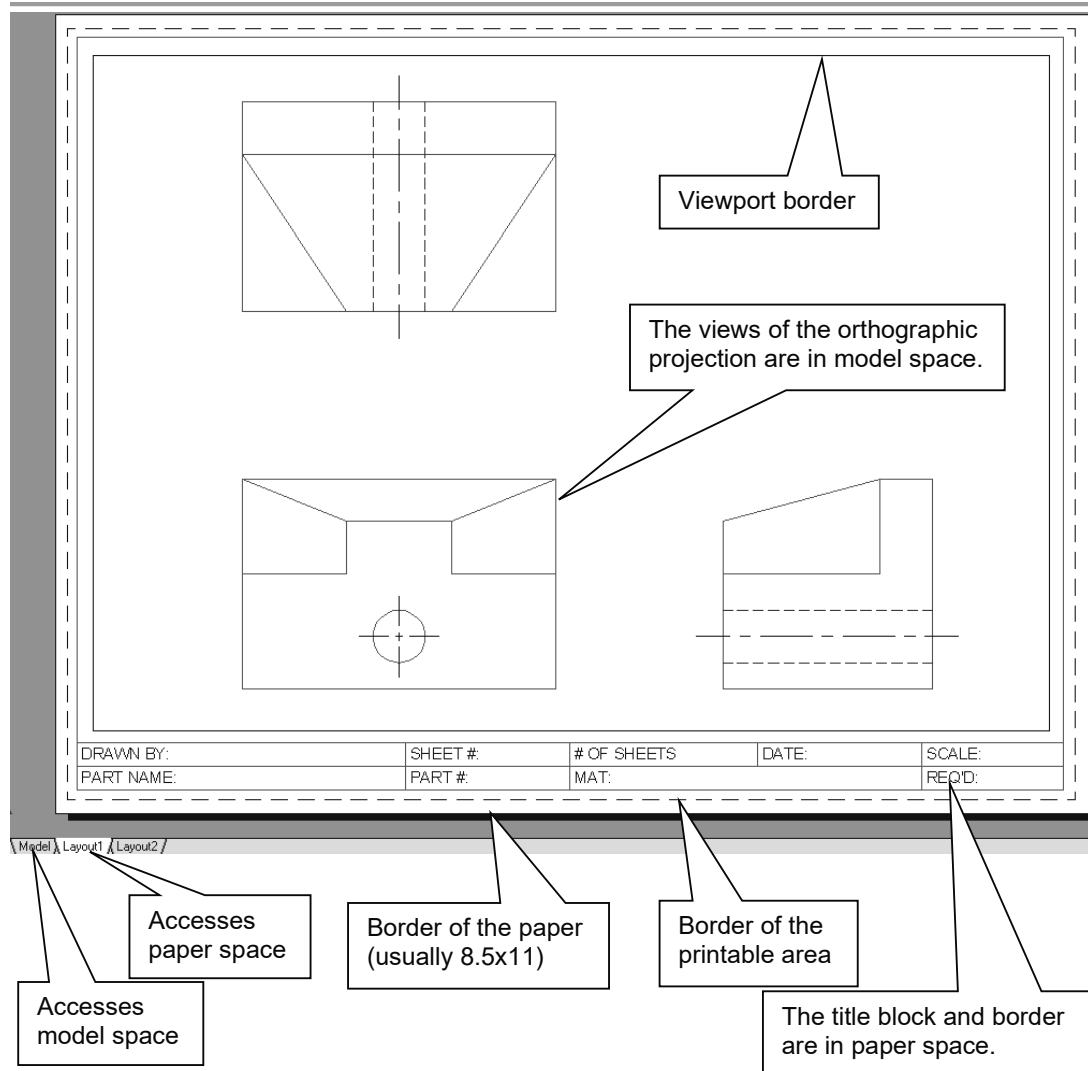

Figure 5.8-1: Paper space

5.9) CENTERLINES

Center lines are used to indicate axis of symmetry among other things. AutoCAD® has specialized commands for creating center marks for circles and arcs as well as center lines for axes of symmetry. Both the **CENTERLINE** and **CENTERMARK** commands create lines that are associative. Which means that they are attached to and change with the particular geometry that was used to define them. Figure 5.9-1 shows the *Centerlines* panel which is located in the *Annotate* tab.

Center lines and center marks may be edited through the use of grip boxes or in the



Properties window (View tab – Palettes panel). If you click on either a center mark or center line, grip boxes will appear allowing you to extend or shorten the line. Figure 5.9-2 shows a grip boxes modification example. Several of the center mark or center line features may be adjusted within the *Properties* window. For example, for a center mark, the cross size and cross gap may be changed. Figure 5.9-3 shows the *Properties* window for both a center mark and a center line.

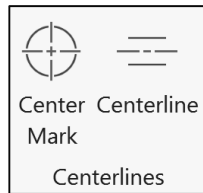

Figure 5.9-1: Centerlines panel

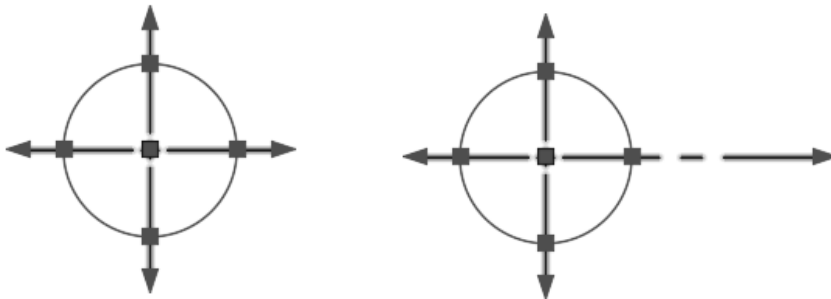

Figure 5.9-2: Grip box modification of a center mark

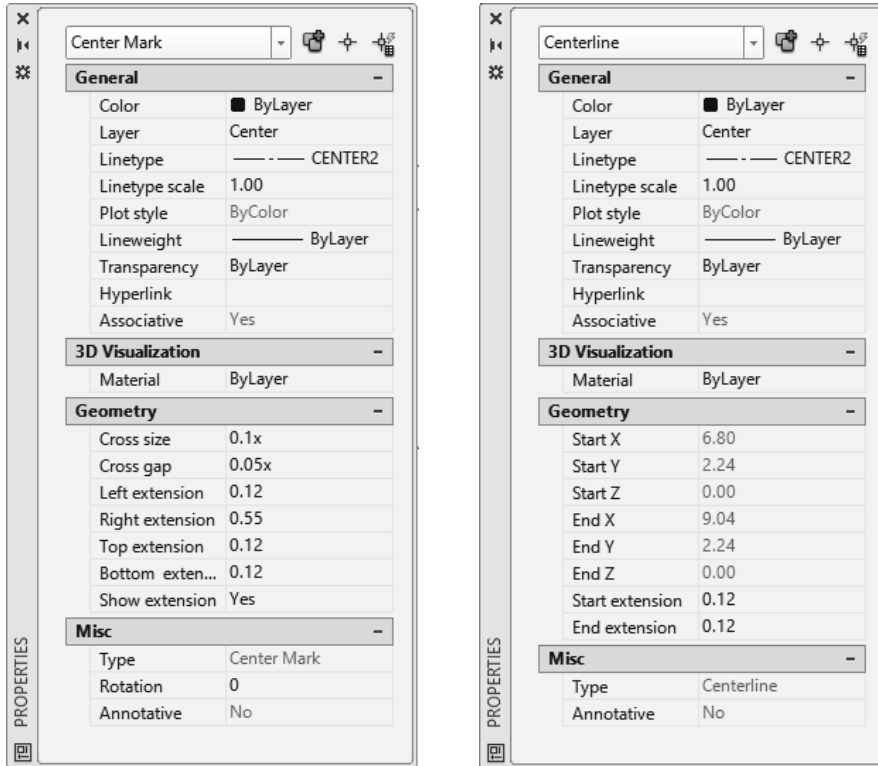

Figure 5.9-3: Center mark and center line *Properties* window

5.10) TITLE BLOCK TUTORIAL

Every engineering drawing should have both a border and a title block. The border defines the drawing area, and the title block gives pertinent information about the part or assembly being drawn. There are several different types of title blocks, but they all contain similar information. The information that is included depends on the drawing type, field of engineering, and viewing audience. The title block specified in the ASME Y14.100 standard is described in the chapter on “Introduction to Engineering Drawings”.

5.10.1) Blocking a title block

- 1) View the *Blocking* video and read section 5.7).

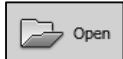

- 2) **titleblock_student_A_2018.dwg**. You will see a basic title block meant to fit an A sized sheet (i.e. 8.5 x 11.)

	11	10	9	8	7	6	5	4	3	2	1	
I	REVISION HISTORY										I	
							ZONE	REV	DESCRIPTION	DATE	APPROVED	
H											H	
G											G	
F											F	
E											E	
D											D	
C											C	
B	UNLESS OTHERWISE SPECIFIED DIM ARE IN INCHES .X ± .1, .XX ± .01 .XXX ± .006, .XXXX ± .0005 ANGULAR ± .3 INTERPRET DIM AND TOL PER ASME Y14.5 - 2006 THIRD ANGLE PROJECTION 				APPROVALS		DATE		COMPANY NAME			
Y					DRAFTER: KAP		2016/05/31					
X					CHECKED:				TITLE			
A					ENGINEER:							
W	MATERIAL		?		SIZE	CAGE CODE	DWG NO	REV				
	FINISH		?		A		?	1				
	DO NOT SCALE DRAWING				SCALE	WEIGHT	SHEET					
					1:1	?	? OF ?					
	11	10	9	8	7	6	5	4	3	2	1	

- 3) Fill in all the standard information into your title block. To edit the text, just double click on it, or you can use the command **DDEDIT**.
 - a) COMPANY NAME = Enter your company or university name.
 - b) DRAFTER = Enter your initials.

- 4) **Zoom All**



6) **BLOCK** your title block and border.

a. Command: **block** or Home Ribbon - Block panel: 

b. Block Definition window:

- i. Name the block **Title Block A**.
- ii. Enter a *Base point* of **0.00, 0.00, 0.00**
- iii. Select all objects that make up your title block and border by selecting the

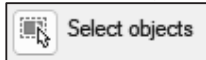

icon. Hit the **Enter** key after you have selected your objects to return to the *Block Definition* window.

- iv. Activate the **Retain** radio button.
- v. Activate the **Annotative** and **Allow exploding** checkboxes.
- vi. Set the *Block units* to **Inches**.
- vii. **OK**

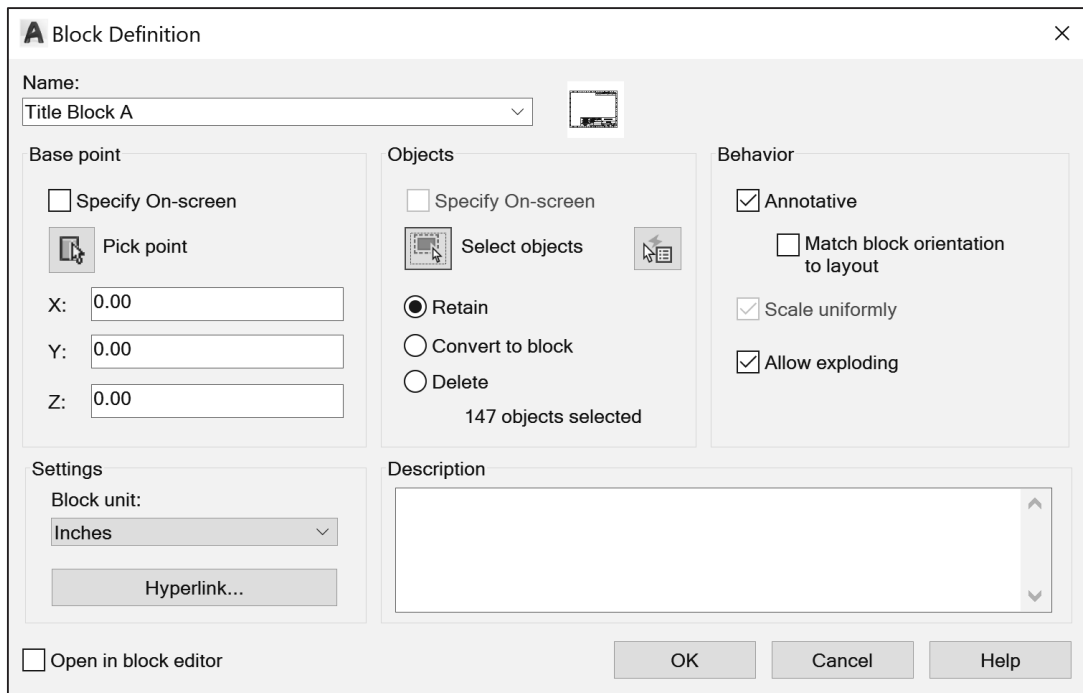

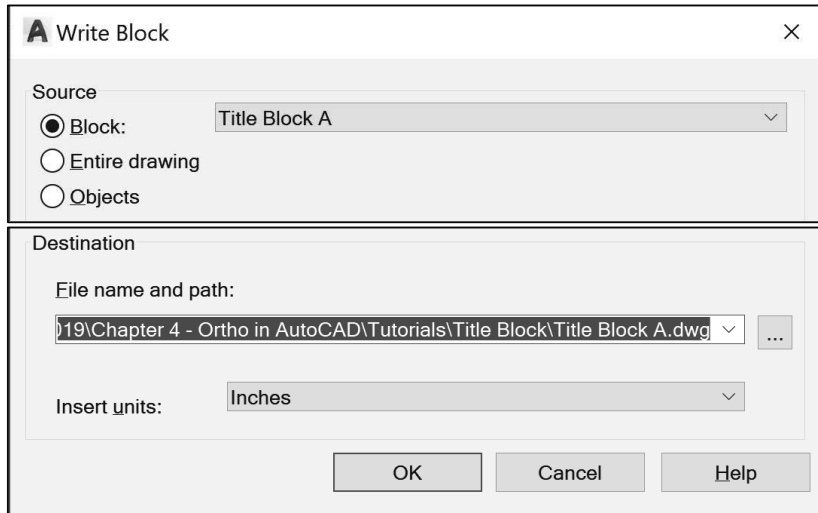

- 7) Write the *Title Block A* block to a file.
 - a) Command: **wblock**
 - b) Write Block window:
 - i. Select the **Block** radio button.
 - ii. Select the **Title Block A** block from the pull-down menu.
 - iii. Select a location for the file by clicking on the file path icon  and name the file **Title Block A**.
 - iv. Select **Inches** as the insert units.
 - v. **OK**



5.10.2) Blocking a metric title block

The Metric sheet size that is closest to an A size sheet (i.e. 11 x 8.5 inches) is the A4 sheet which is 297 x 210 mm (i.e. 11.7 x 8.3 inches).

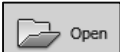
- 1) View the *Blocking* video and read section 5.7).

- 2)  **Open** *titleblock_student_A4_2018.dwg* and  **Save As** **Title Block A4.dwg**. You will see a basic title block meant to fit an A4 sized sheet (i.e. 297 x 210 mm)
- 3) Fill in all the standard information into your title block. To edit the text, just double click on it, or you can use the command **DDEDIT**.
 - a) COMPANY NAME = Enter your company or university name.
 - b) DRAFTER = Enter your initials.

- 4) **Zoom All**

- 5)  **Save**

6) **BLOCK** your title block and border.

- a. Command: **block** or Block panel:  Create
- b. Block Definition window:
 - i. Name the block **Title Block A4**.
 - ii. Enter a *Base point* of **0.00, 0.00, 0.00**
 - iii. Select all objects that make up your title block and border using the **Select objects** icon. Hit the **Enter** key after you have selected your objects to return to the *Block Definition window*.
 - iv. Activate the **Retain** radio button.
 - v. Activate the **Annotative** and **Allow exploding** checkboxes.
 - vi. Set the *Block units* to **Millimeters**.
 - vii. **OK**

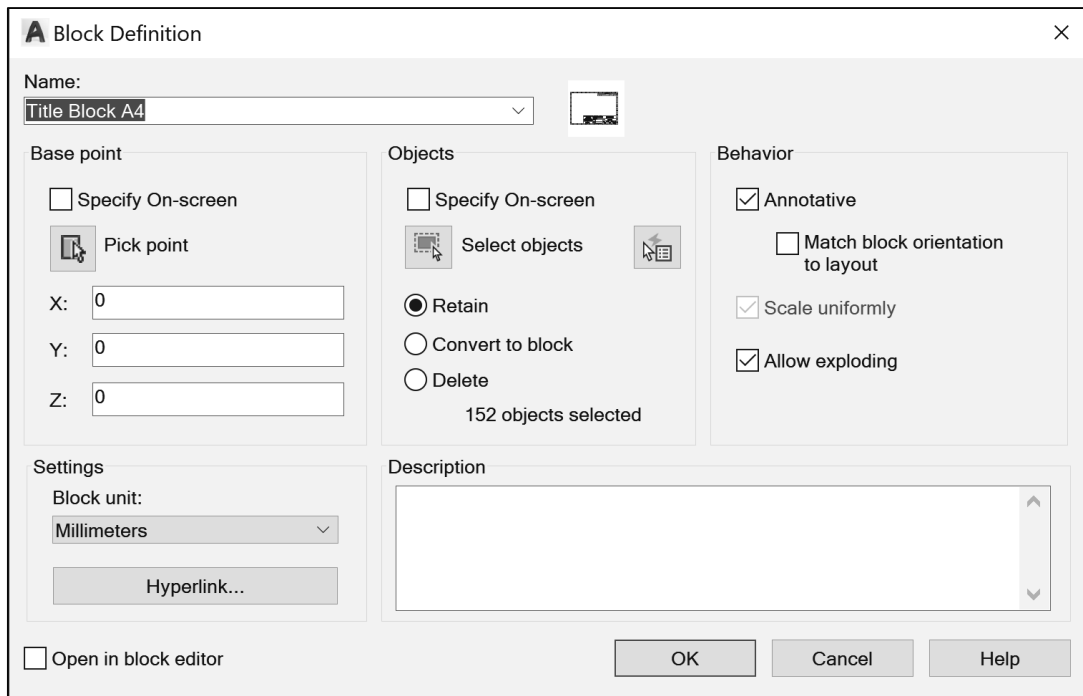

- 7) Write the *Title Block mm* block to a file.
- c) Command: **wblock**
 - d) Write Block window:
 - i. Select the **Block** radio button.
 - ii. Select the **Title Block A4** block from the pull-down menu.
 - iii. Select a location for the file by clicking on the file path icon  and name the file **Title Block A4**.
 - iv. Select **mm** as the insert units.
 - v. **OK**

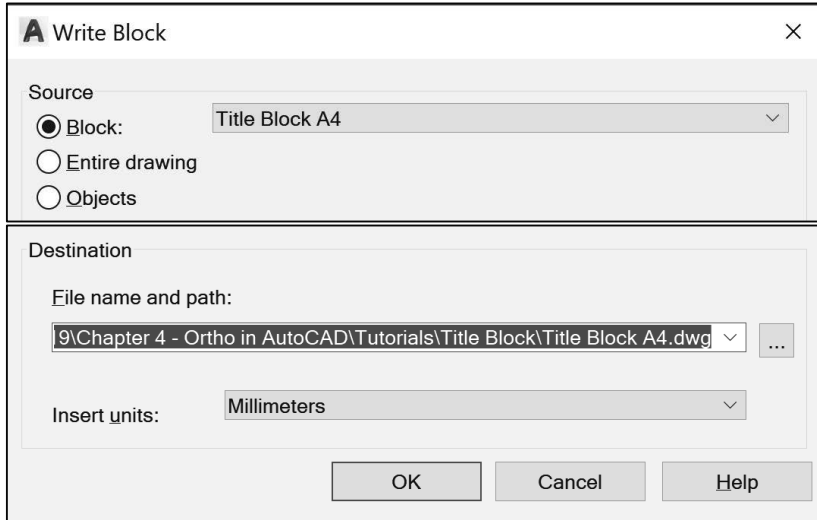

Exercise 5.10-1: Creating Blocks

Open ***titleblock_student_B_2018***. This is a title block that will fit a B sized sheet of paper (17 x 11 inches). Open ***titleblock_student_A3_2018***. This is a title block that will fit an A3 sized sheet of paper (420 x 297 mm). **Block** and **Wblock** each title block for use later.

5.11) ORTHOGRAPHIC PROJECTION TUTORIAL

By the end of this tutorial, you will have created and printed an orthographic projection of the part shown using proper pen widths. We will draw the orthographic projection using the procedure explained in the chapter on “*Orthographic Projections*”. We will start by drawing the front view and use projectors to construct the top and right side views. Visible, hidden, and centerlines will be drawn on their own layer. Once the drawing is complete, we will use both the model space and the layout space to plot the drawing.

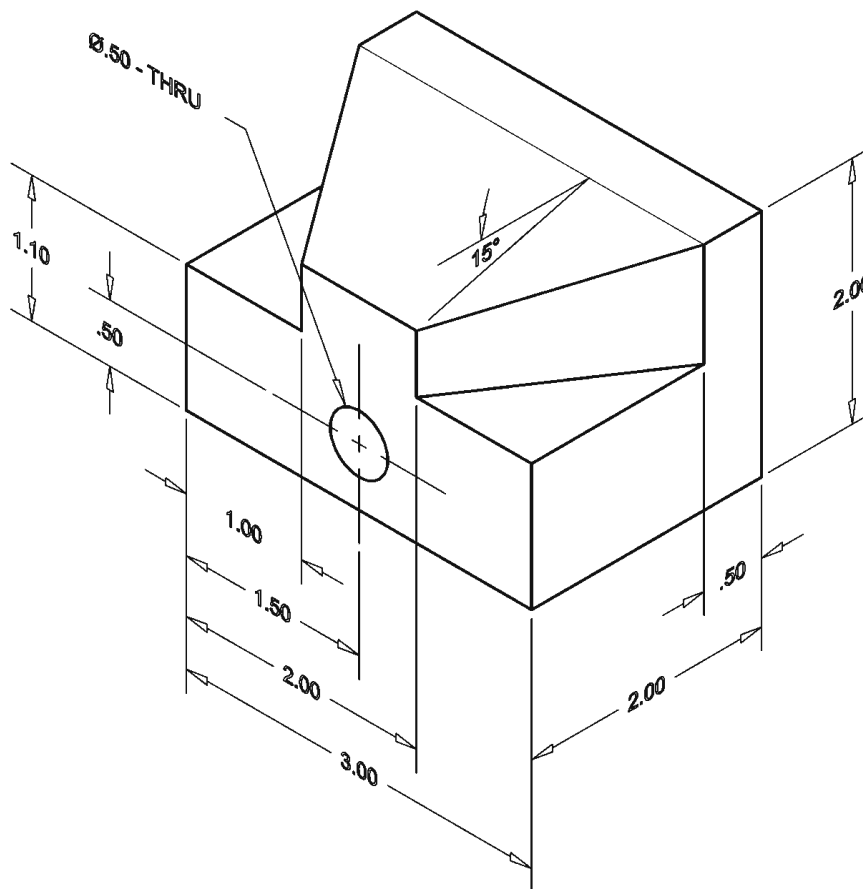

5.11.1) Draw the front view

- 1) View the *Model - Layout*, *Printing from model space*, and *Printing from layout space* videos and read sections 5.8) and 5.9).
- 2) Take some time to sketch what you think the FRONT, TOP and RIGHT SIDE views of the above object will look like.

- 3)  **set-inch.dwt** and  **Ortho Tut.dwg**. Save periodically throughout this tutorial.

- 4) Enter your WCS  (Located in the **Visualize** tab. You can also access the World Coordinate system using the command **UCS**.)

Note: If the **Visualize** tab is not active perform the following steps.

- a) **Right click** on the ribbon.
- b) Select **Show Tab**
- c) Select **Visualize**

- 5) If you are using *Dynamic Input*, set the *Pointer Input Format* to **Absolute coordinates**.
- 6) In the **Viewport** layer, draw a **RECTangle** that indicates the edges of your limits/paper (11x8.5).
- 7) **Zoom All**
- 8) In your **Visible** layer, draw the visible lines of the front view.
- a) Draw a **RECTangle** that is **3 inches** long and **2 inches** wide near the bottom left corner of your drawing area.
 - b) Set your **UCS** origin  to the bottom left corner of the front view.
 - c) Draw the **2 Lines** within the rectangle.
 - d) Draw the **Circle**. (Note: \varnothing = diameter)

Note: Some visible features are missing, but this is all we can do for now.

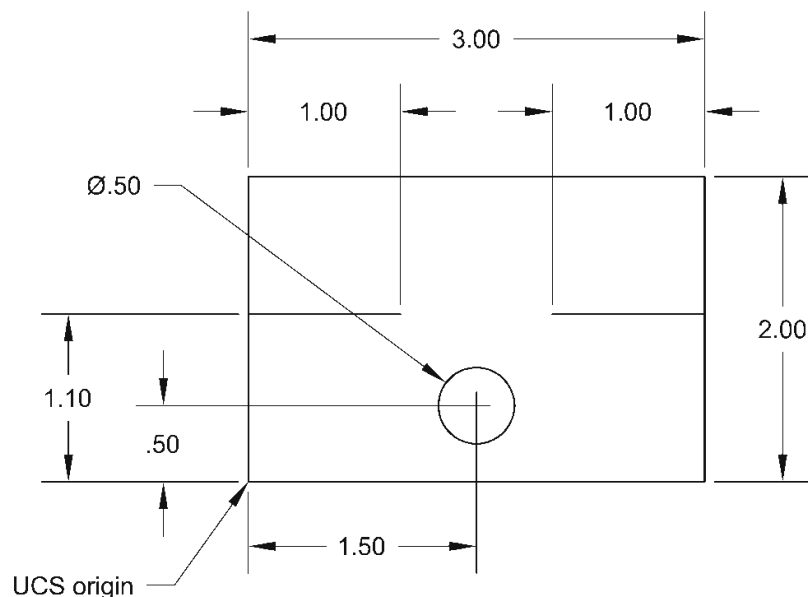

5.11.2) Drawing the right side view

- 1) Turn your **Object Snap** on and set the following object snaps to be automatically detected (Endpoint, Midpoint, Center, Quadrant, Intersection, Nearest, Perpendicular, Extension).

2) In the **Construction** layer, draw horizontal and vertical construction lines (**XLine**) off of every edge and boundary of the front view.

a) Create the horizontal projectors.

- i. Command: **xl** or Draw panel: 
- ii. Specify a point or [Hor/Ver/Ang/Bisect/Offset]: **h**
- iii. Specify through point: **Select every corner, edge and quadrant that should have a horizontal projector coming off of it.**
- iv. Specify through point: **Enter**

b) Create the vertical projectors.

c) Move the visible lines of the front view above the construction lines.

- i. Home tab - Modify panel:  Bring to Front
- ii. Select objects: **Using a window, select all the visible lines of the front view.**
- iii. Select objects: **Enter**

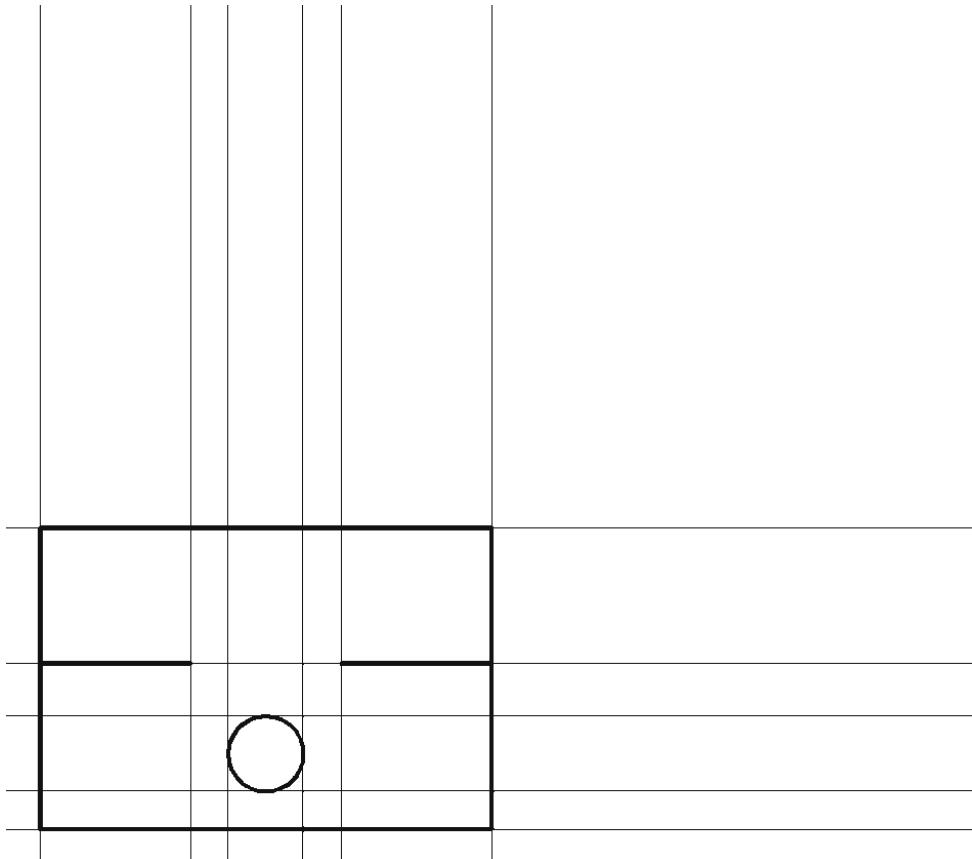

3) In the **Visible** layer, draw the visible features of the L-shaped part of the right side view.

How?

- 1) Command: **line** or 
- 2) Specify first point: Select a point that is **NEArest Projector 1**. (See the figure below.)
- 3) Specify next point or [Undo]: **@2<0**
- 4) Specify next point or [Undo]: Select a point that is **PERpendicular to Projector 2**.
- 5) Specify next point or [Close/Undo]: **@.5<180**
- 6) Specify next point or [Close/Undo]: Select a point that is **PERpendicular to Projector 3**.
- 7) Specify next point or [Close/Undo]: **@1.5<180**
- 8) Specify next point or [Close/Undo]: Close the shape by snapping to the **ENDpoint**.
- 9) Specify next point or [Close/Undo]: **Enter**

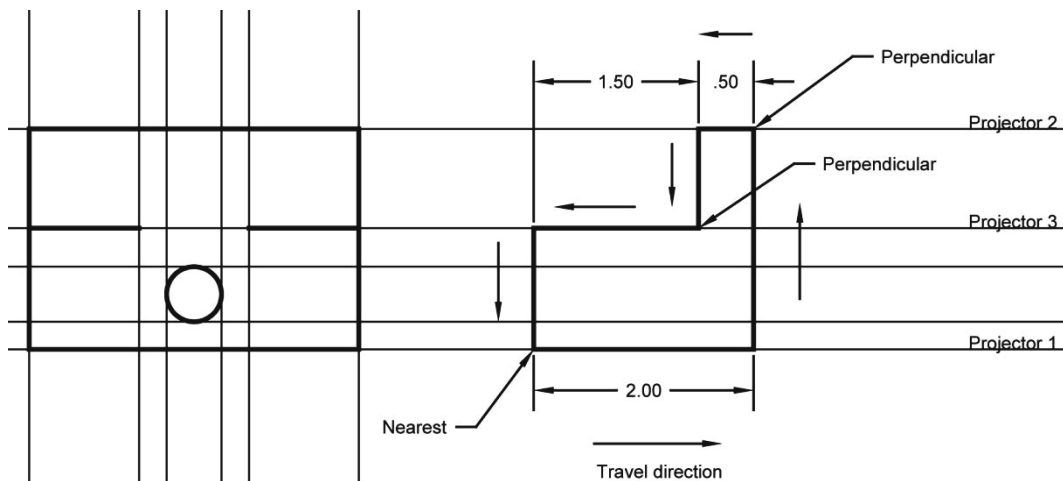

- 4) Draw the angled feature of the right side view using the following commands.
 - a) Turn the **Polar Tracking** on and set **POLARANG** to 15 degrees.
 - b) Use a polar tracking path and the **EXTension** snap to construct the angled line.
 - c) Connect the angled line with the L-shaped body.

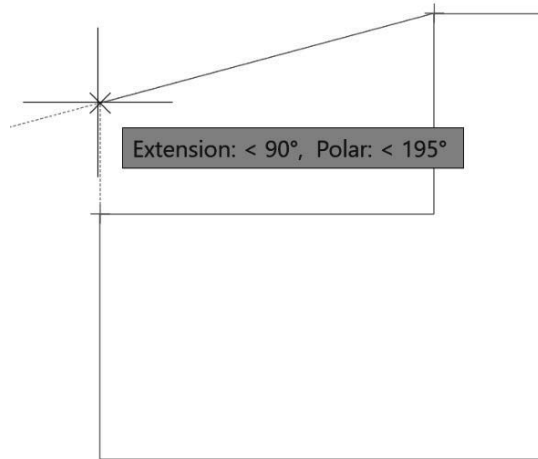

- 5) In the **Construction** layer, project the angled feature of the right side view back to the front view.
- 6) In the **Visible** layer, draw the missing visible lines in the front view.
- 7) In the **Hidden** layer, draw the rectangular view of the hole in the right side view.
- 8) Set your line type scale (**LTSCALE**) to **0.5**.

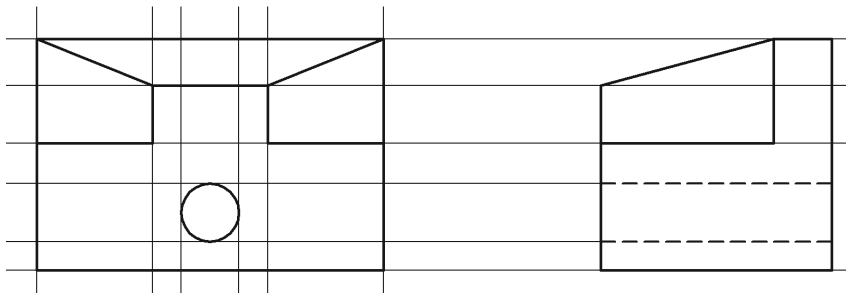

5.11.3) Drawing the top view

- 1) In the **Construction** layer, draw the projectors needed to complete the top view.
 - a) Draw a 45° projector off the upper right corner of the front view.
 - i. **Command:** **xl** or **Draw panel:** 
 - ii. Specify a point or [Hor/Ver/Ang/Bisect/Offset]: **a**
 - iii. Enter angle of xline (0) or [Reference]: **45**
 - iv. Specify through point: **Select the upper right corner of the front view.**
 - v. Specify through point: **Enter**
 - b) Draw vertical projectors up from the right side view and horizontal projectors over to where the top view will be located.

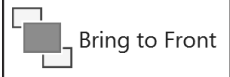
- c) Use the  icon to bring the lines of the right side view to the front.
 -

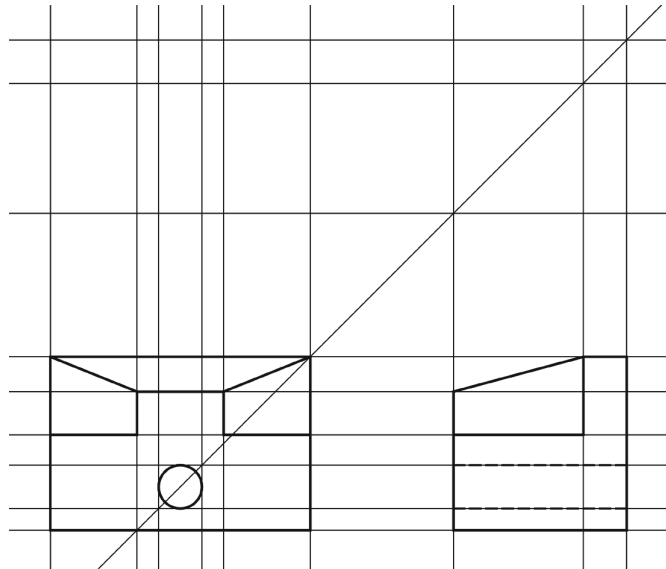

2) Draw the visible and hidden features of the top view.

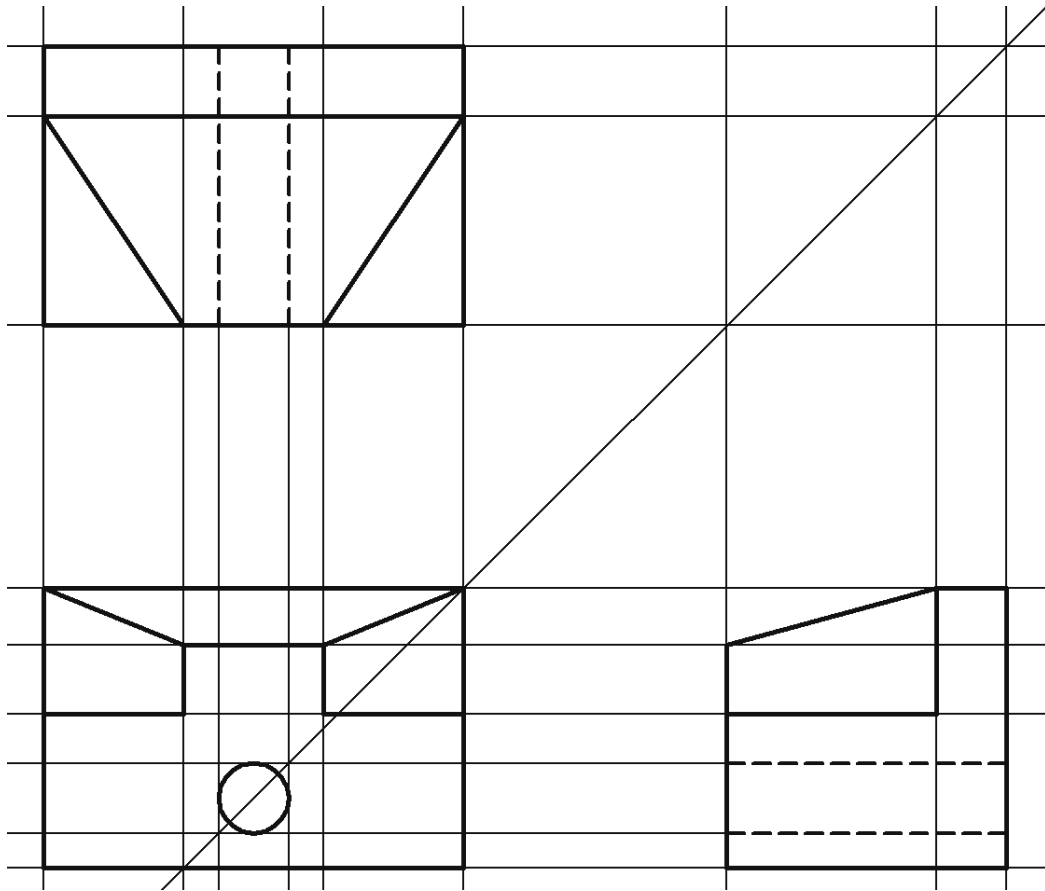

3) Turn the **Construction** layer off.

Click on the light bulb to turn the layer off.

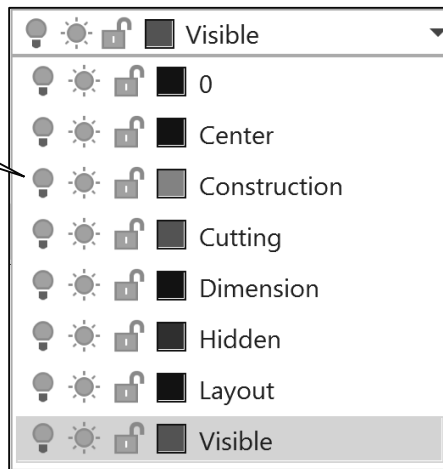

5.11.4) Drawing centerlines

- 1) In the **Center** layer, add the center mark for the hole in the front view.



- a) Annotate Tab – Centerlines panel: or **CENTERMARK**
 b) Select circle or arc to add centermark: Click on the circle.

- 2) Add the centerlines in the right side and top views.

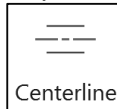

- a) Annotate Tab – Centerlines panel: or **CENTERLINE**
 b) Select first line: Click on one of the lines that will define the centerline location.
 c) Select second line: Click on the other line.

Note: Don't worry if your centerlines don't look correct. We will fix them later.

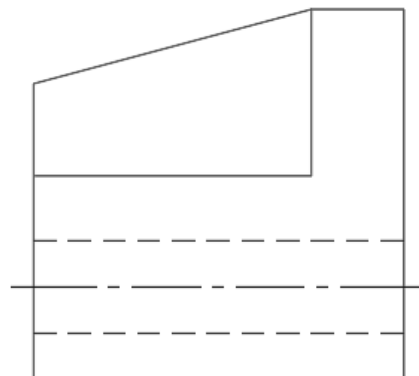
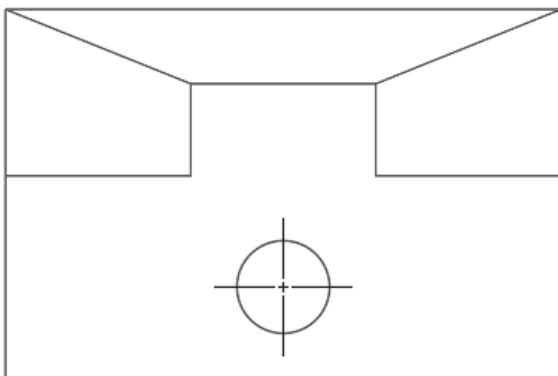
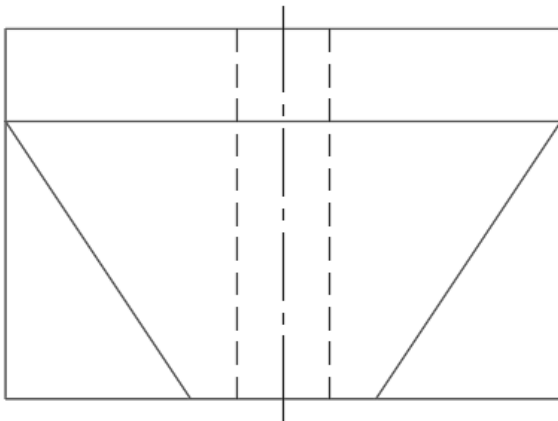

- 3) Notice that the center mark and centerlines have very small dashes. Let's fix that.
- Click on the center mark.



- View tab – Palettes panel:
- Change the *Cross size* to **0.3x** and the *Cross gap* to **0.1x**.
- Change all of the *extensions* to **0.12**.

- 4) Fix the centerlines.
- Click on both of the centerlines.



- View tab – Palettes panel:
- Change the *Linetype* to **CENTER** instead of CENTER2.
- Change the *Start* and *End extension* to **0.12**.

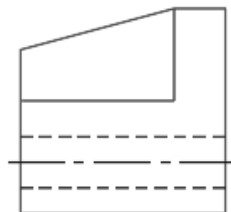
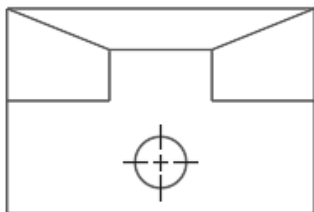
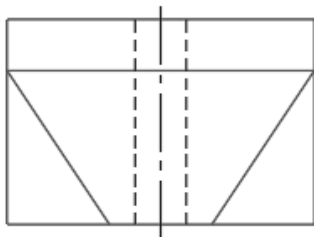
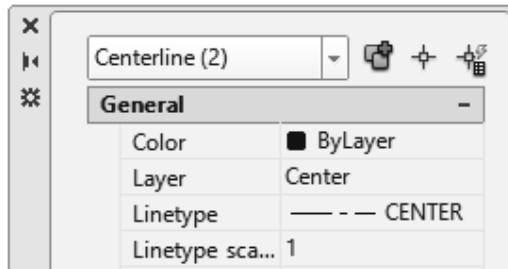
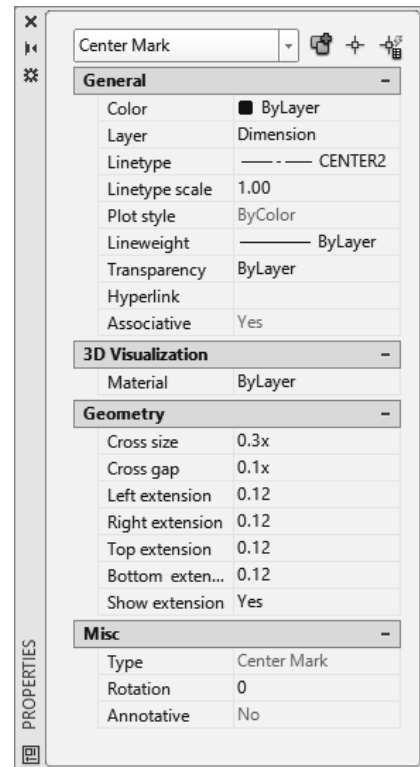

- Make sure that all three views are within the limits rectangle that you drew.

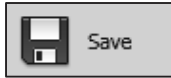



6)

5.11.5) Printing the layout

- 1) Select the **Layout1** tab at the bottom of your drawing screen.
- 2) Insert your inch title block.



- a) Command: **insert** or Block panel:  and then **Blocks from Libraries...** If this is your first time inserting a block it will automatically go to the file navigation window; otherwise, it will go directly to the **Blocks** window.
- b) If you are in the **Blocks** window, select  to navigate the file. **Open the Title Block A** block file.
- c) Check the **Insertion Point** check box. This will allow you to choose an insertion point on the screen.

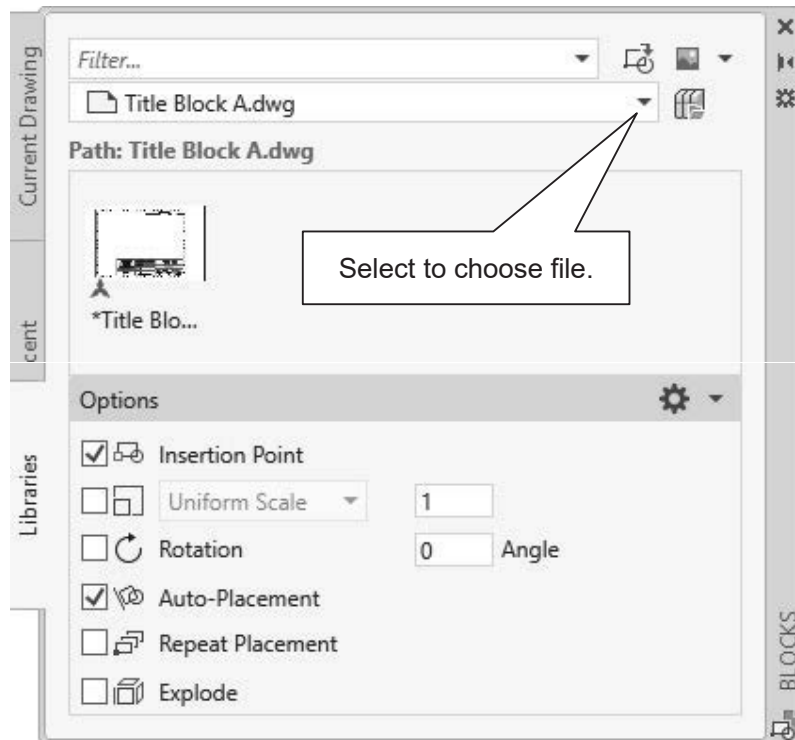

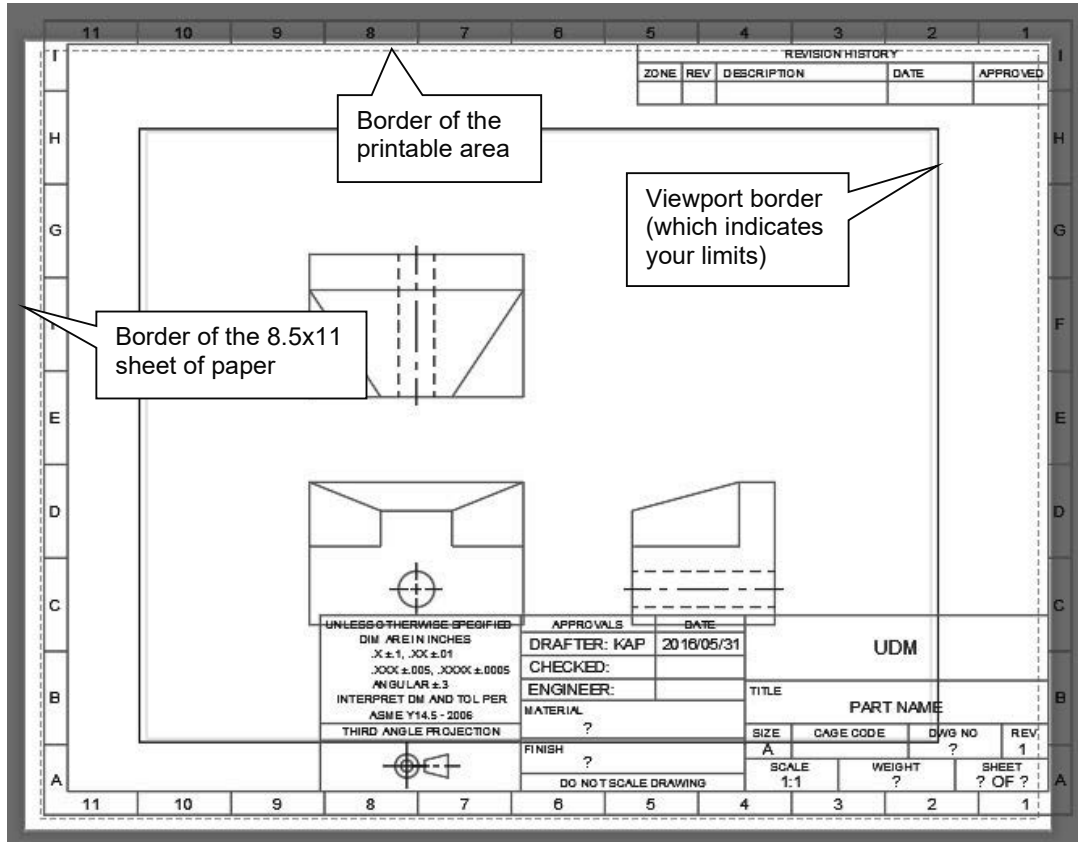

- d) Select the **Title Block A** picture and manually specify an insertion point to be just inside the lower left corner of the printable area. The printable area is indicated by a light line. This should be the biggest rectangle shown on the page. The size of this area depends on the type of printer being used. (See the figure below.)

- 3) Notice the features of the layout (see the figure below). At this point, you should see:
- The border of the 8.5x11 sheet of paper.
 - The border of the printable area. The size of the printable area is printer dependent.
 - The viewport border.
 - The orthographic projection is in model space.
 - The rectangle that you drew to indicate the 11x8.5 limits (yellow). Therefore, the objects in the model are not being shown at a 1:1 scale relative to paper space.
 - Note that your title block may be too big. We will take care of that later.

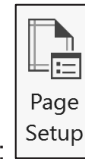

4) Set your pen widths and page size.



- a) Application button:  **Print – Page Setup...** or Layout Tab:
- b) Page Setup Manager window: **Modify...**
- c) Page Setup – Layout1 window:
- Select a printer.
 - Plot the **Layout**.
 - Select a **1:1** scale.
 - Plot style table (pen assignments) area: Select **monochrome.ctb** from the pull-down menu.
 - Select the **Edit...**  icon next to the pull-down menu. A *Plot Style Table Editor* window will appear.
- d) Plot Style Table Editor – monochrome.ctb window:
- Plot styles field: Select **Color 1** (red – visible line color).
 - Lineweight field: Select **0.6000 mm** from the pull-down menu.
 - Follow the same procedure to set the widths of the other line types.
 - Color 5** (blue – hidden) = **0.45 mm**
 - Color 7** (black – center and dimension lines) = **0.3 mm**
 - Save & Close**
- e) Page Setup – Layout1 window: **OK**
- f) Page Setup Manager window: **Close**

Note: Every setting except the pen widths are saved within the drawing file and will not change unless you change them. The pen widths are computer specific and will have to be re-entered if you change computers.

Note: You may also set pen width within the Layers Properties Manager if you find this easier (see figure below). However, this method gives you a limited number of pen widths. Therefore, you notice that the hidden line is given a pen width of 0.50 mm when a better width is 0.45 mm.

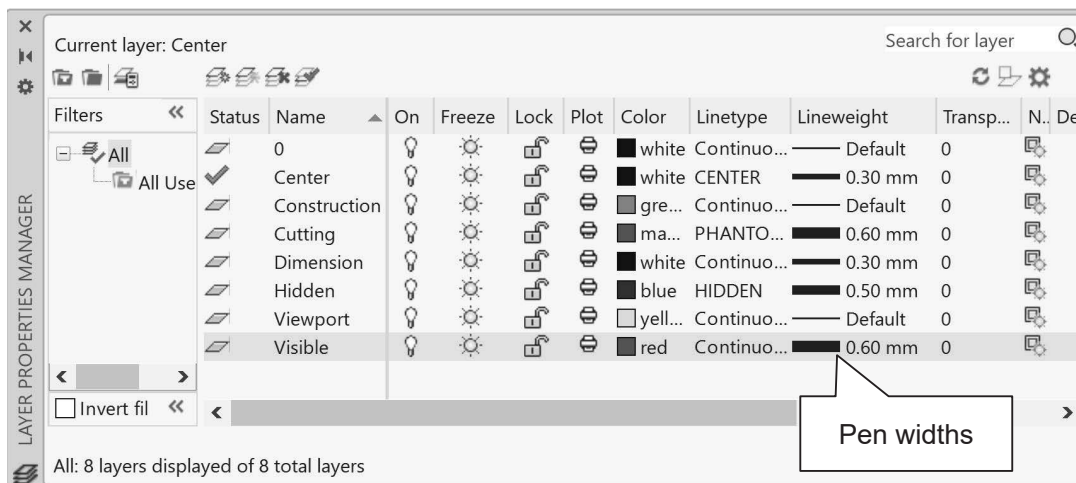

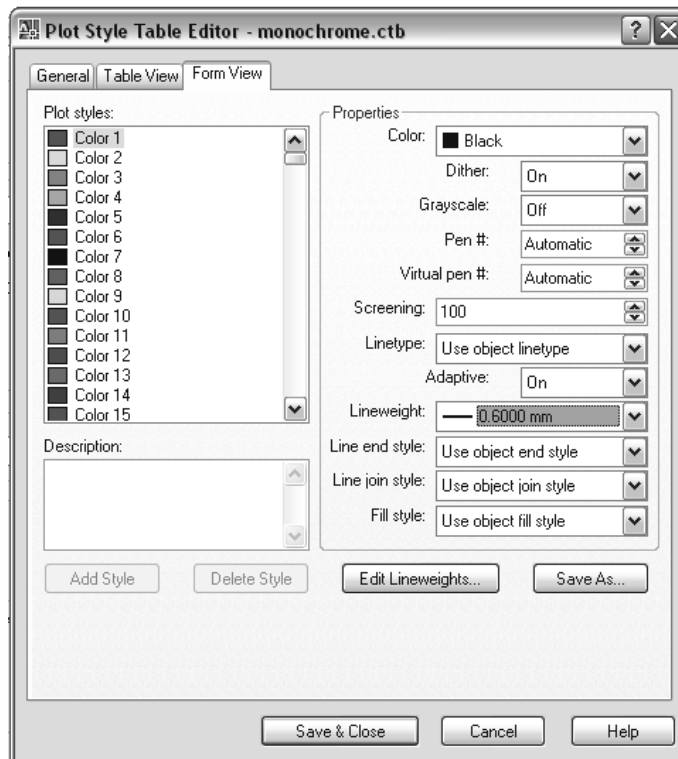
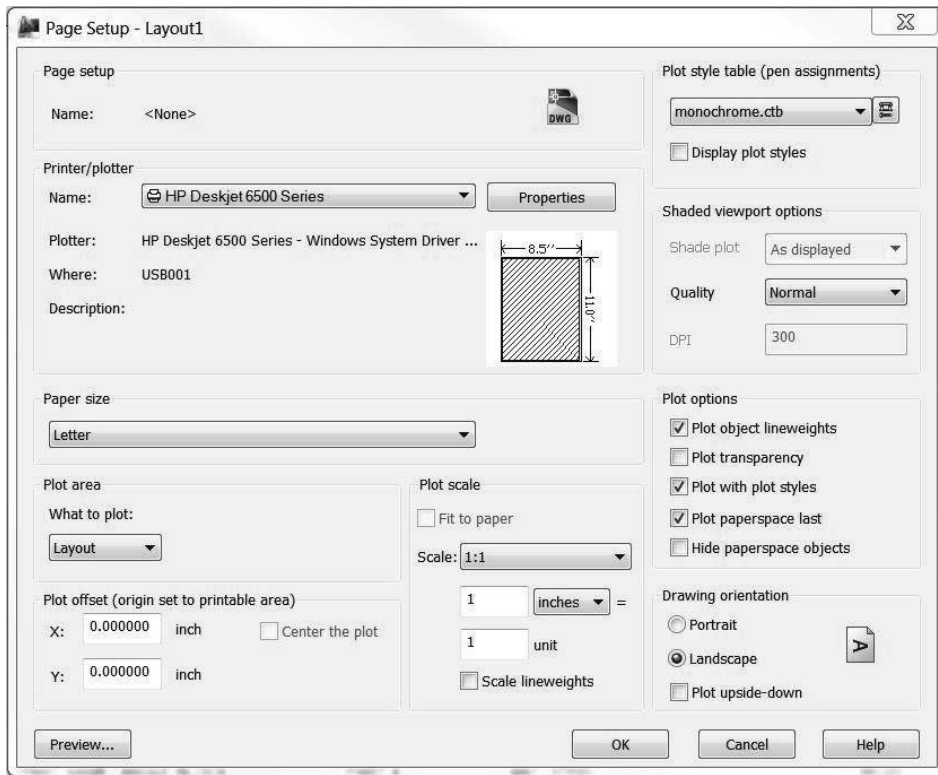

- 5) Move your viewport border to the **Viewport** layer.
- 6) If your title block extends beyond the printable area, **Scale** your title block using the lower left-hand corner as the base point. The scale percentage depends on your printer selection. For me it was 93%.
- 7) Use the **Move** command to center your title block within the printable area.
- 8) Click on the viewport border to activate its grip boxes. Using the grip boxes, resize the viewport border so that it is just inside your title block border. **Caution!** Don't make it the same size as your title block border. We will need to access the viewport border often.

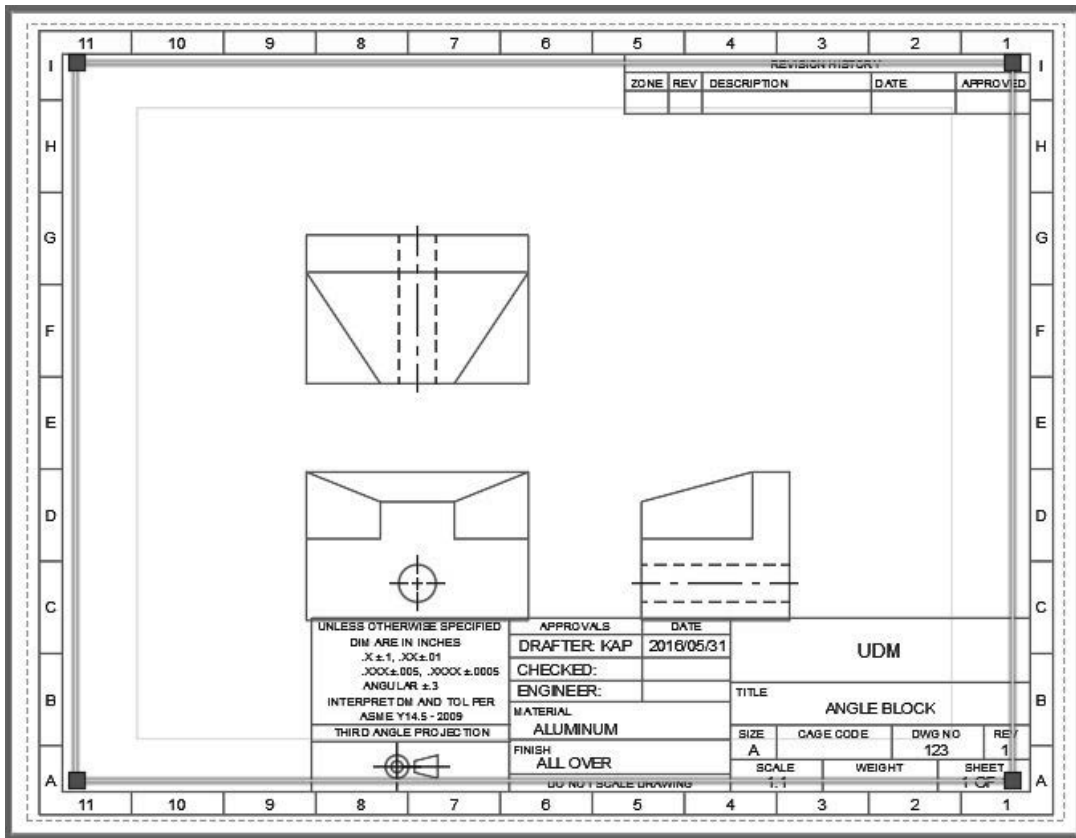

- 9) With the view port still selected, notice that a *Viewport Scale* is added to the *Status* bar. The *Viewport Scale* indicates the scale at which objects within the view port are shown relative to

the paper space. If you have more than one view port, each view port may have a different scale.

- 10) Click on the *Viewport Scale* and change it to **1:1**.
- 11) Double click inside the viewport border. This activates the model space and the viewport border will thicken. Use the **Pan** and **Move** commands so that the orthographic projection is centered within the title block border. Double click outside the viewport border to re-enter paper space.
- 12) Turn **OFF** your *Viewport* layer.

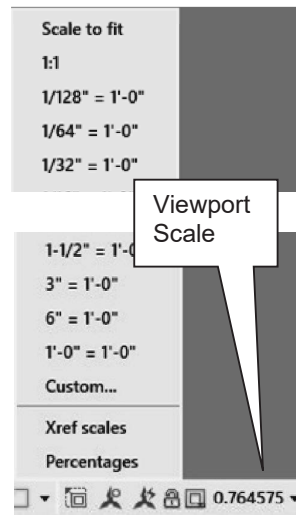

13) Fill in your title block. In order to enter text, we need to break the title block into its individual entities.

- a) Command: **explode** or Modify panel: 
- b) Select objects: Select any part of the title block.
- c) Select objects: **Enter**

14) Edit your text by using the DDEDIT command or by double clicking on the word to edit.
Enter the following information.

- a) PART NAME = ANGLE BLOCK
- b) SIZE = A
- c) SCALE = 1:1
- d) DWG NO = 123
- e) WEIGHT = delete the ?.
- f) SHEET = 1 OF 1
- g) DATE = Enter the appropriate date
- h) MATERIAL = ALUMINUM
- i) FINISH = ALL OVER

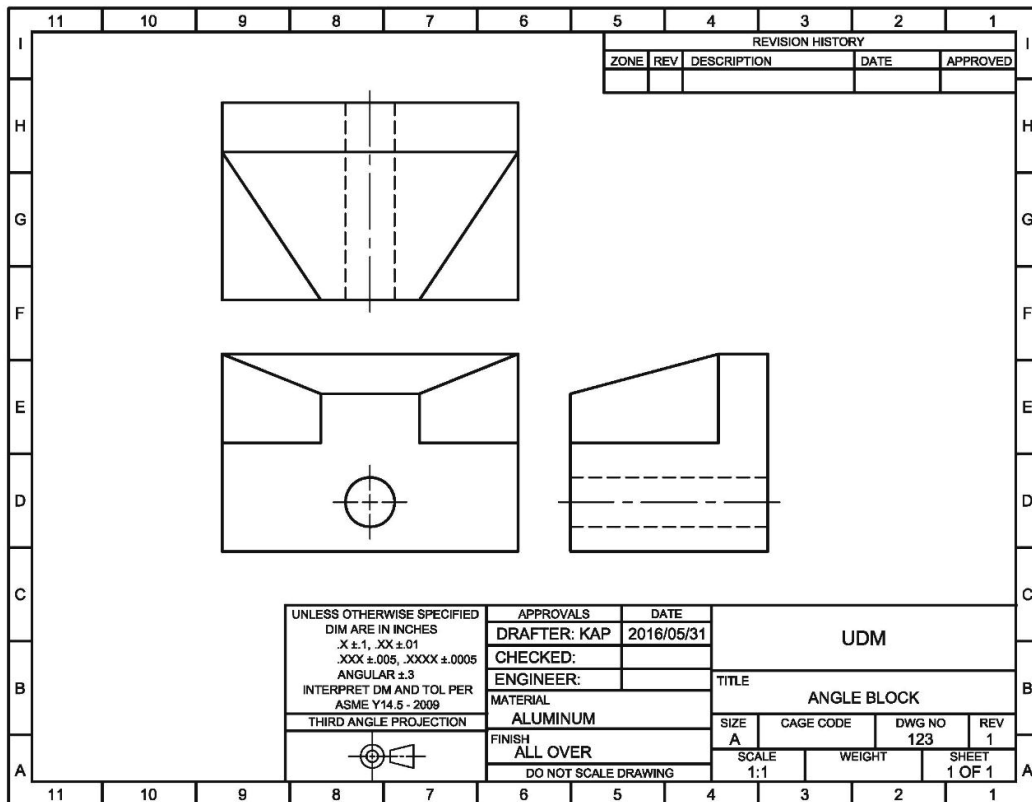

15) Plot your drawing.

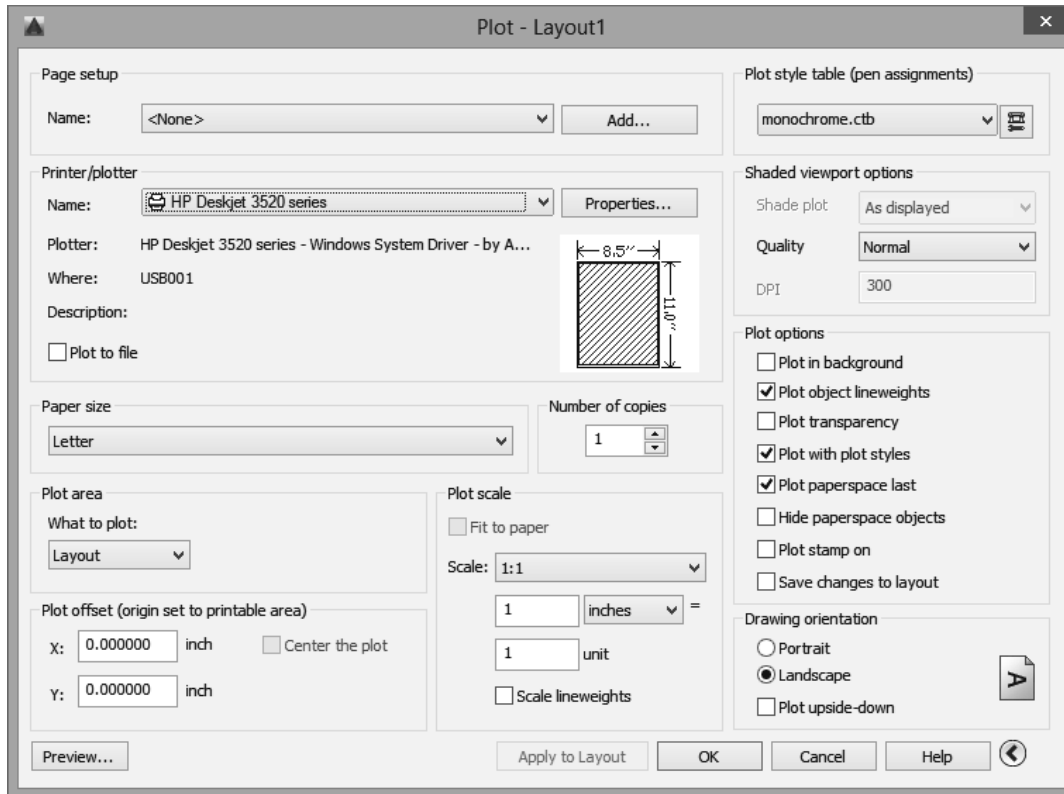

- a) Application button: **Print – Plot...**
- b) Plot - Layout1 window: **Preview...**
- c) Hit **Esc** to exit print preview.
- d) If the preview did not appear as you expected, adjust your settings and **Preview...** the drawing again. Check to make sure your pen widths are set correctly and your line breaks look right.
- e) Plot - Layout1 window: Select **OK** when everything is set correctly.



16) Switch back to your model space by clicking the **Model** tab at the bottom of the drawing screen. Notice that your title block disappears. This is because layout objects do not appear in the model space.

17)  Save

5.11.6) Printing a metric drawing

- 1)  **ortho_metric_student_2018.dwg**. This file contains a metric version of the orthographic projection completed in the previous sections.
- 2)  **Ortho Metric Tut.dwg**
- 3) Verify that the drawing is indeed metric. On the **Viewport** layer, draw a limits **RECTangle** that is **297 x 210** mm whose lower left corner starts at **0,0**.
- 4) **Zoom All**
- 5) Enter **Layout** space.
- 6) Move your viewport border to the **Viewport** layer.

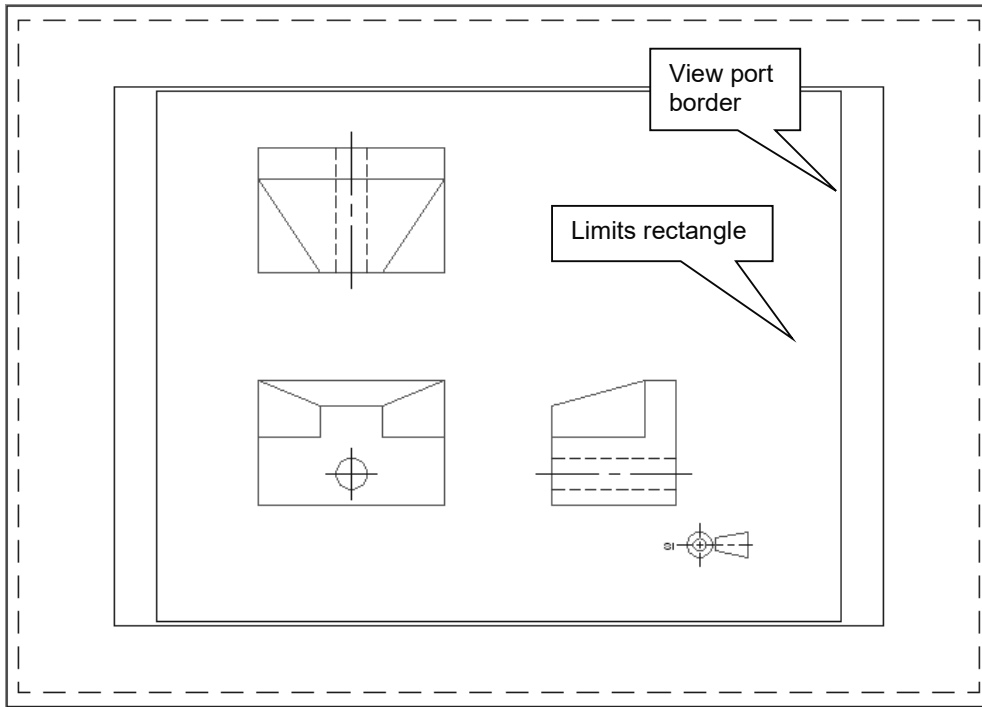

- 7) Enter the **Page Setup – Layout1** window (**Print – Page Setup... - Modify**) and set the following parameter.
 - a) Paper size = **ISO A4 (297.00 x 210.00 MM)**.
 - b) Plot scale area:
 - i. Scale = **1:1**
 - c) Plot style = **monochrome.ctb**
 - d) **OK**
 - e) **Close**

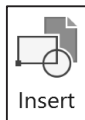
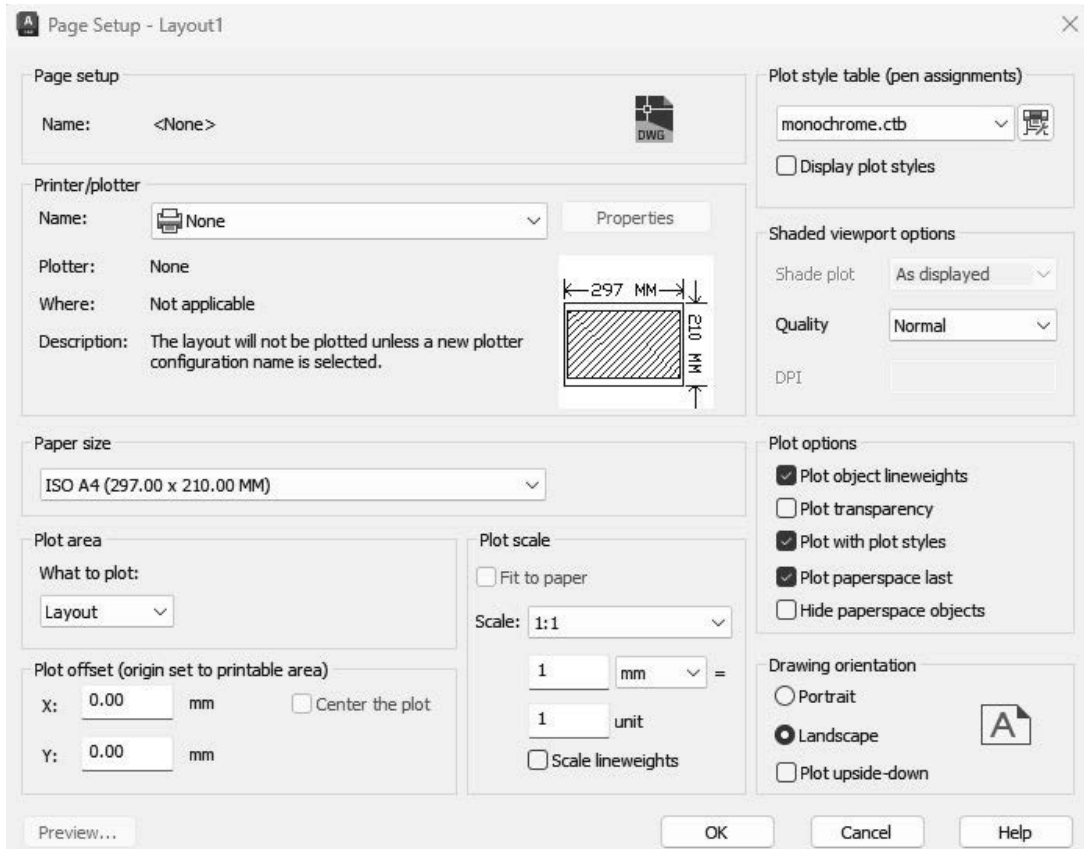

- 8) **INSERT** your **Title Block A4**, center the title block and **Scale** (if necessary) to fit within your printable area.
- 9) Fill in your title block, adjust your view port border, set the **Viewport Scale** to 1:1, center your model, turn the **Viewport** layer **off**, fill in your title block, **save** and **print** your drawing. Note, you will have to **EXPLODE** your title block in order to fill in the fields. (See figure on the next page.)

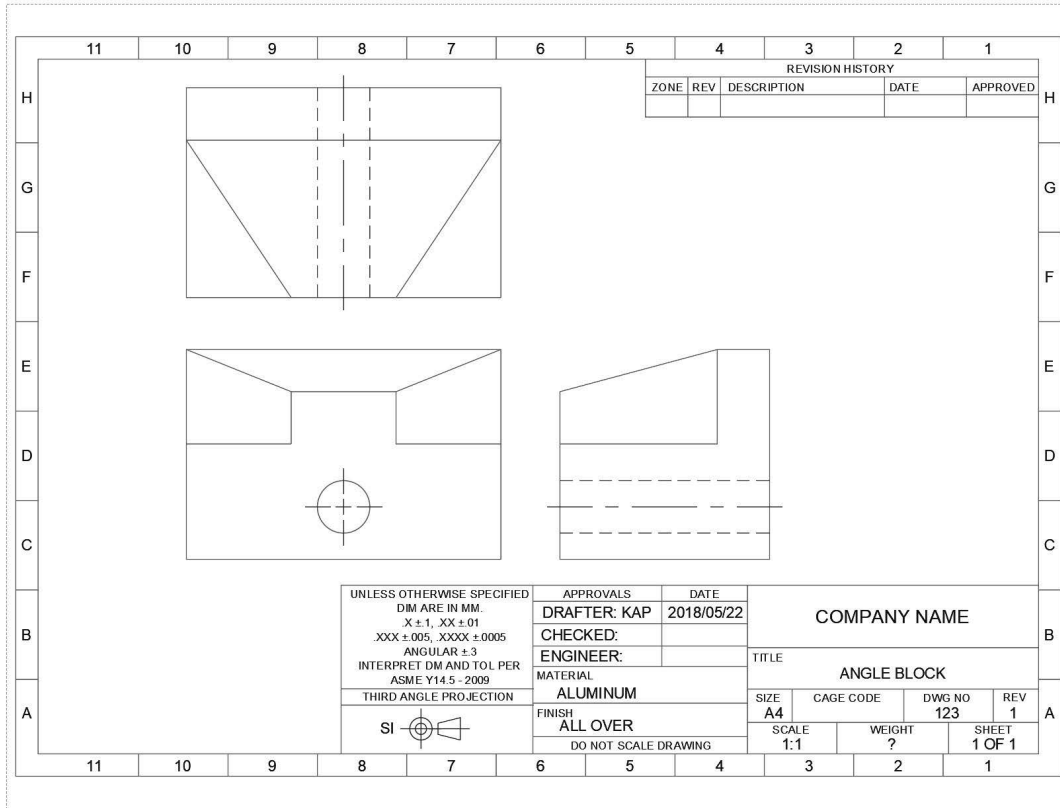

NOTES:

ORTHOGRAPHIC PROJECTIONS IN AUTOCAD® QUESTIONS

Name: _____ Date: _____

Layers

Q5-1) The layer you are drawing on is said to be

1. on.
2. first.
3. on top.
4. current.

Q5-2) What layer property controls an entity's printed width?

- a) line type
- b) layer name
- c) color
- d) pen style

Q5-3) The construction layer is used to create projection lines. When the orthographic projection is complete, we do not need these lines anymore. The easiest way to not show the projections lines is to turn the construction layer to the _____ state.

- a) freeze
- b) thaw
- c) off
- d) on

Q5-4) Lines occurring on a LOCKED or OFF layer may not be selected. Which layer status still allows you to see the lines?

Q5-5) The place/window where you can change a layer's color, linetype and status.

- a) Layer properties manager
- b) Layers manager
- c) Layer status manager

Q5-6) The typed command that is used to control the length of the dashes and spaces of the different line types.

- a) ltscale
- b) scale
- c) dashscale
- d) setscale

Q5-7) To change the line type scale of an individual object, you must enter the window.

- a) scale
- b) properties
- c) line type
- d) page setup

Blocking

Q5-8) A grouping of objects that may be reused.

- a) group
- b) nest
- c) pair
- d) block

Q5-9) What typed command is used to write a block to a file?

- a) block
- b) create
- c) wblock
- d) insert

Q5-10) The command used to break a block up into its individual components.

- a) ungroup
- b) explode
- c) break apart
- d) Insert

Name: _____ Date: _____

Model/layout space and printing

Q5-11) The space where you see exactly what is going to be printed. (circle all that apply)

- a) model
- b) layout
- c) paper
- d) real

Q5-12) An area within layout space that allows you to view objects within model space and to scale these objects with respect to the printed page.

- a) viewport
- b) model view
- c) paper space

Q5-13) How do you access model space while still remaining in paper space?

- a) Click on the model tab.
- b) Double click within the viewport border.
- c) Type "model"
- d) Click on the viewport border.

Q5-14) The typed command that allows you to create a new viewport.

- a) viewports
- b) port
- c) newport
- d) newview

Q5-15) What pen styles table is used if you want to print in black and white?

- a) color
- b) gray
- c) black and white
- d) monochrome

Q5-16) The typed command used to edit existing text.

- a) ddedit
- b) edit
- c) text edit
- d) tedit

NOTES:

ORTHOGRAPHIC PROJECTIONS IN AUTOCAD® PROBLEMS

P5-1) Create an orthographic projection of the following object. Draw the three standard views. Dimensions given in inches.

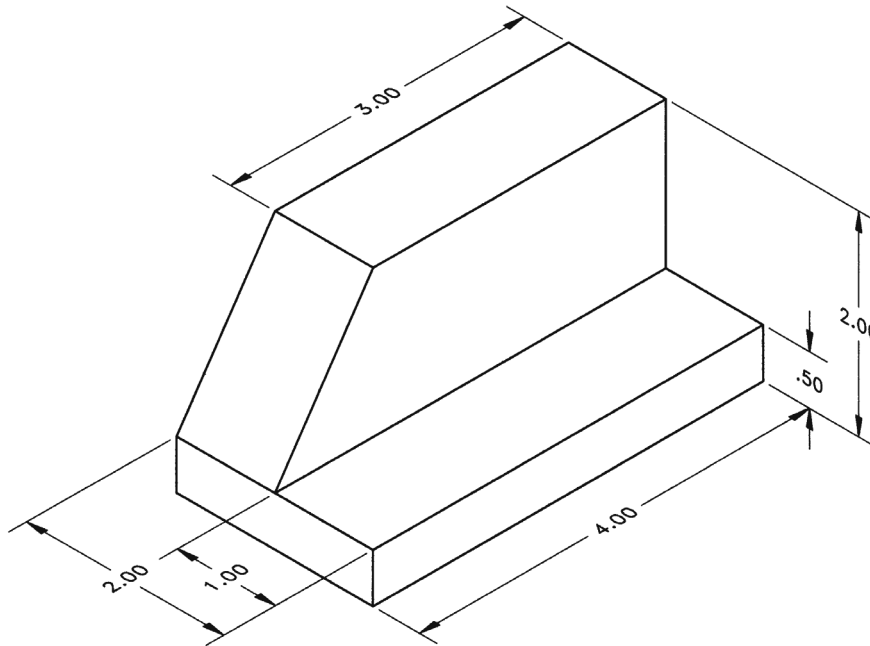

P5-2) Create an orthographic projection of the following object. Draw the three standard views. Dimensions given in inches.

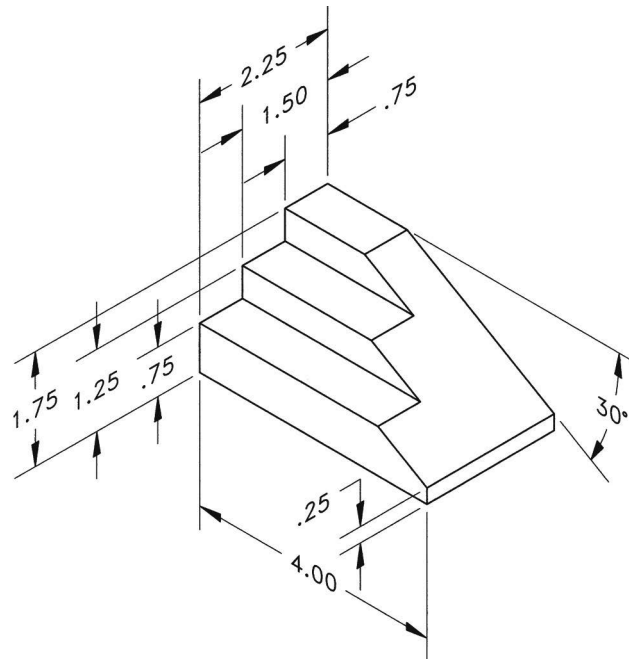

P5-3) Create an orthographic projection of the following object. Draw the three standard views. Dimensions given in inches.

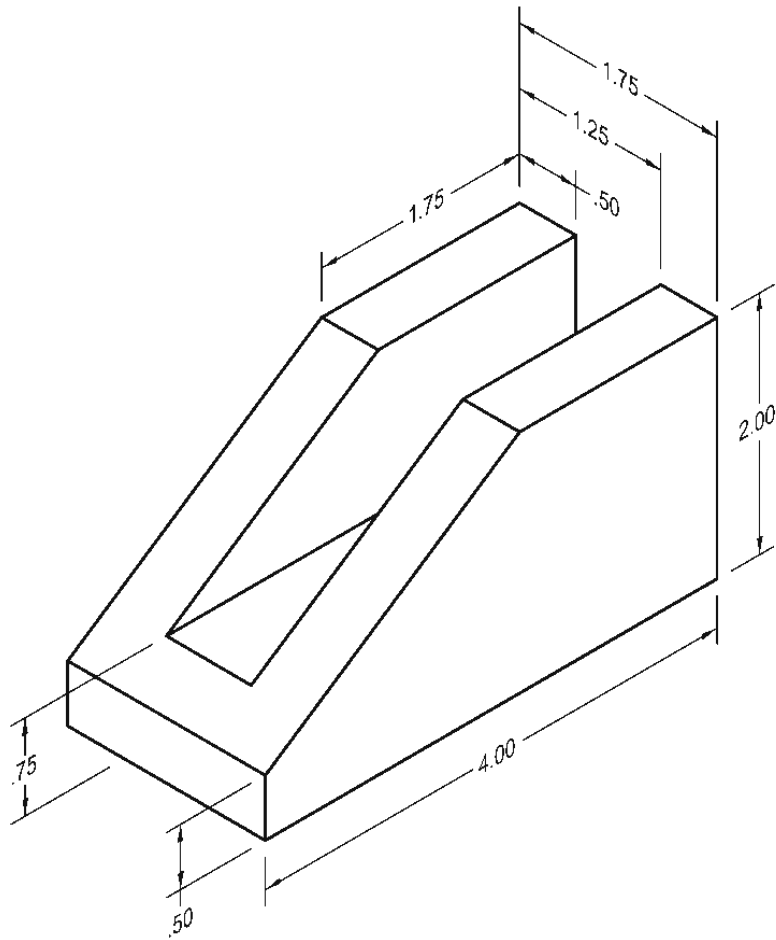

P5-4) Create an orthographic projection of the following object. Draw the three standard views. Dimensions given in millimeters.

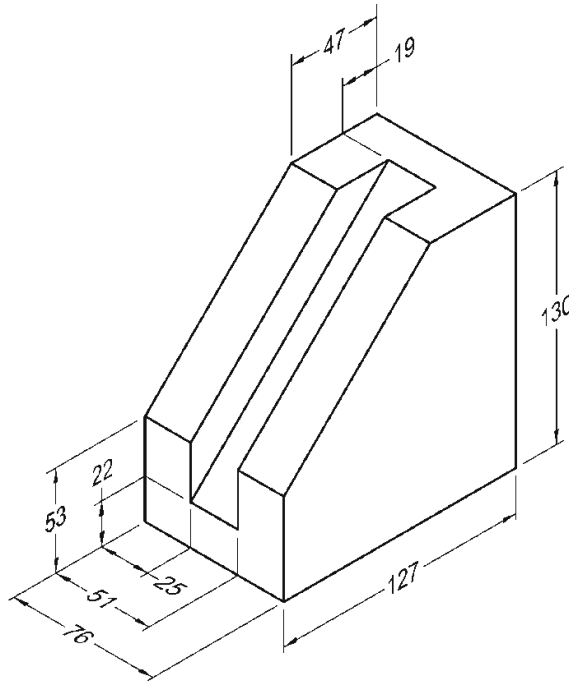

P5-5) Create an orthographic projection of the following object. Draw the three standard views. Dimensions given in millimeters.

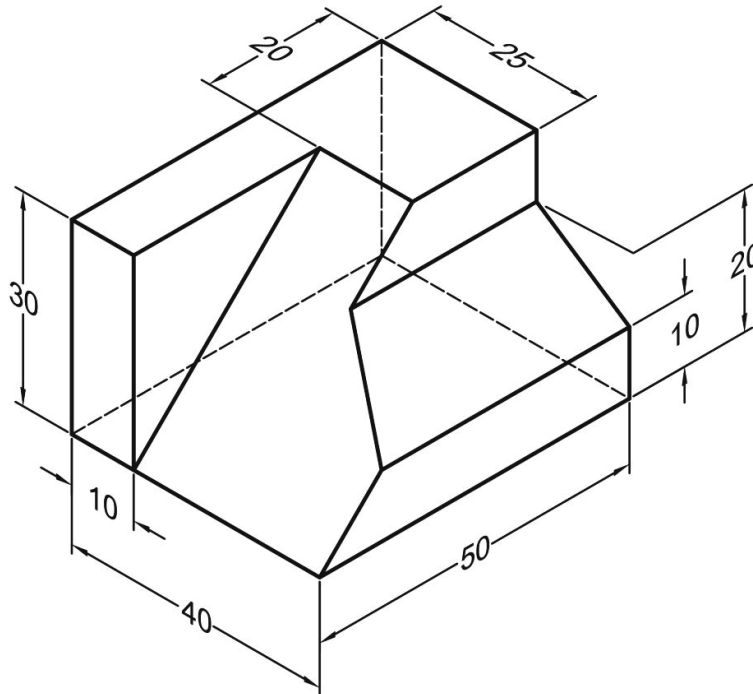

P5-6) Create an orthographic projection of the following object. Draw the three standard views. Dimensions given in inches.

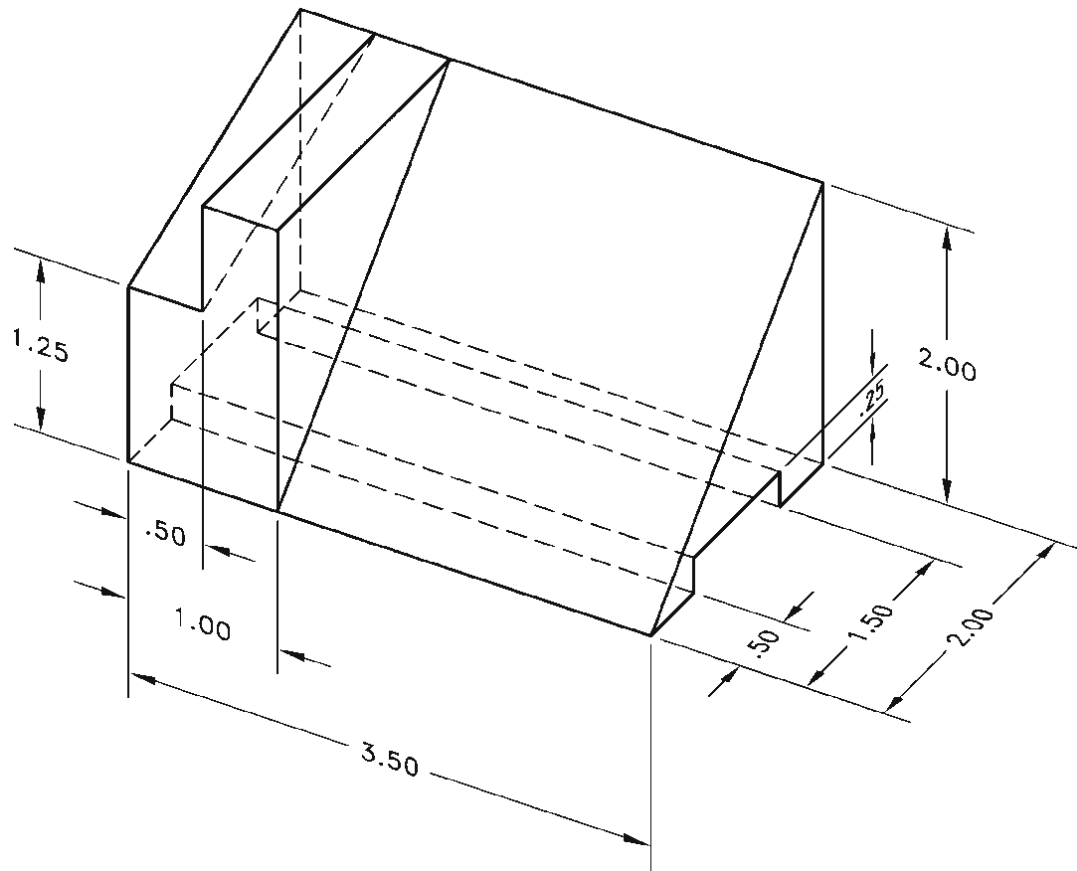

P5-7) Create an orthographic projection of the following object. Draw the three standard views. Dimensions given in inches.

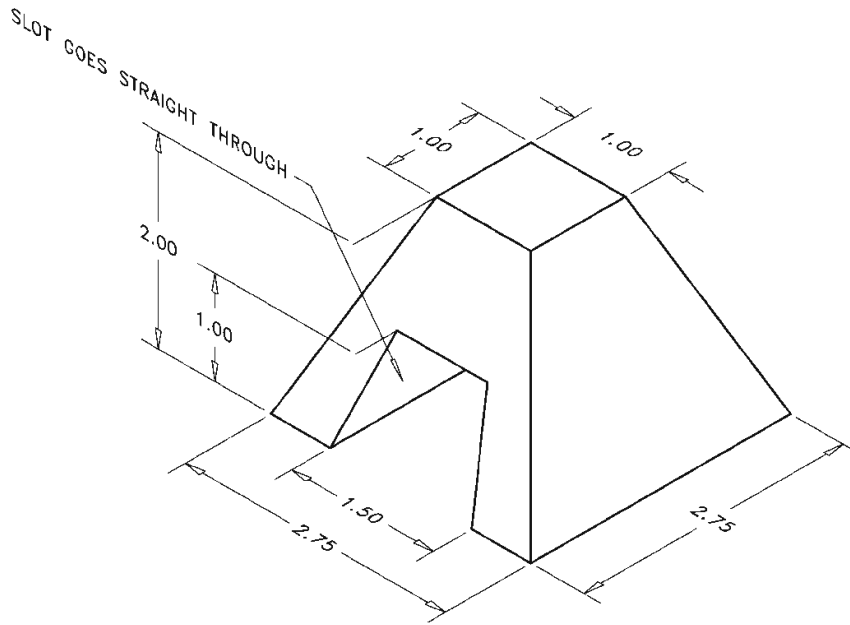

P5-8) Create an orthographic projection of the following object. Draw the three standard views. Dimensions given in inches.

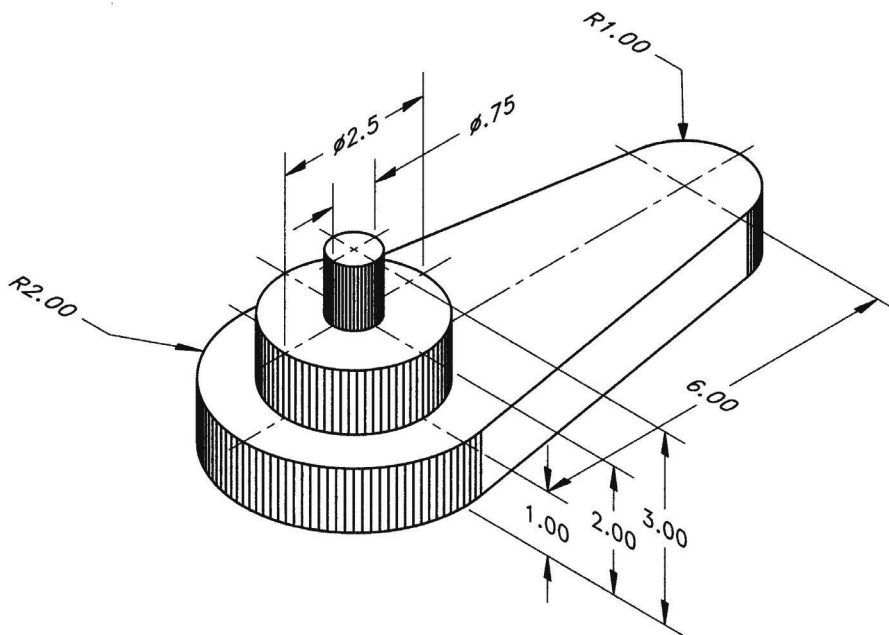

P5-9) Create an orthographic projection of the following object. Draw the three standard views. Dimensions given in inches.

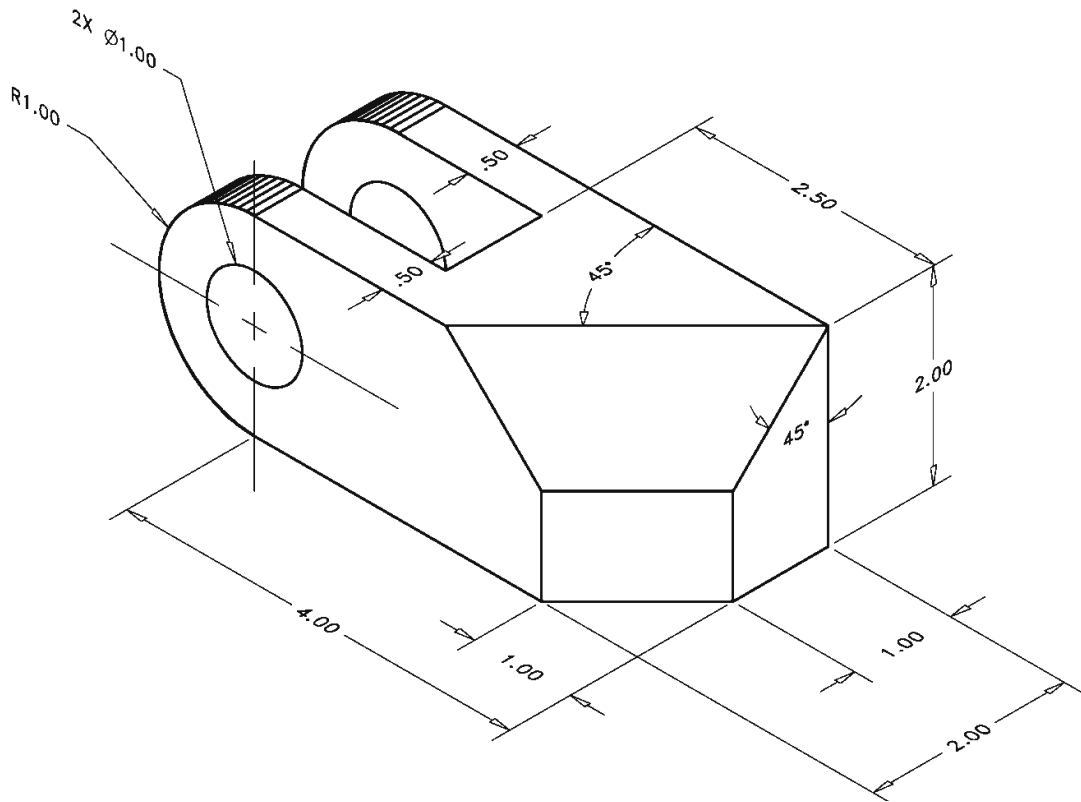

P5-10) Create an orthographic projection of the following object. Draw the three standard views. Dimensions given in inches.

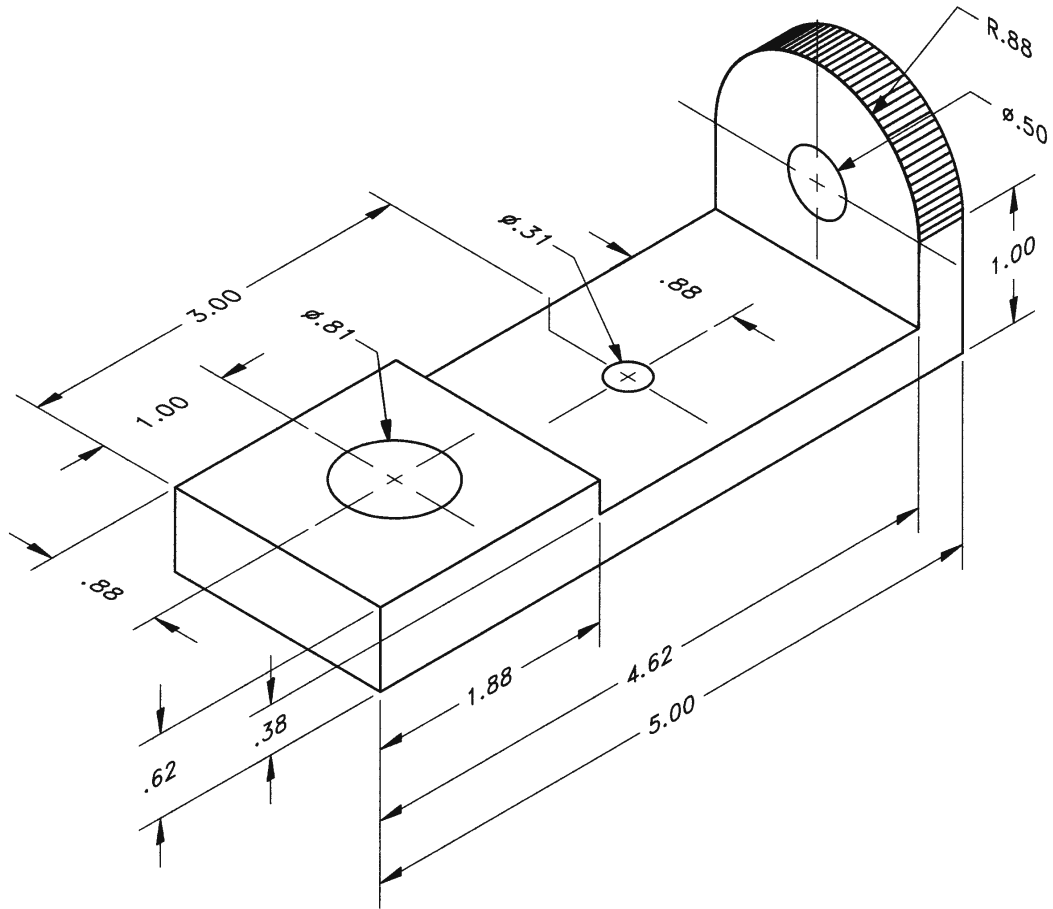

P5-11) Create an orthographic projection of the following object. Draw the three standard views. Dimensions given in millimeters.

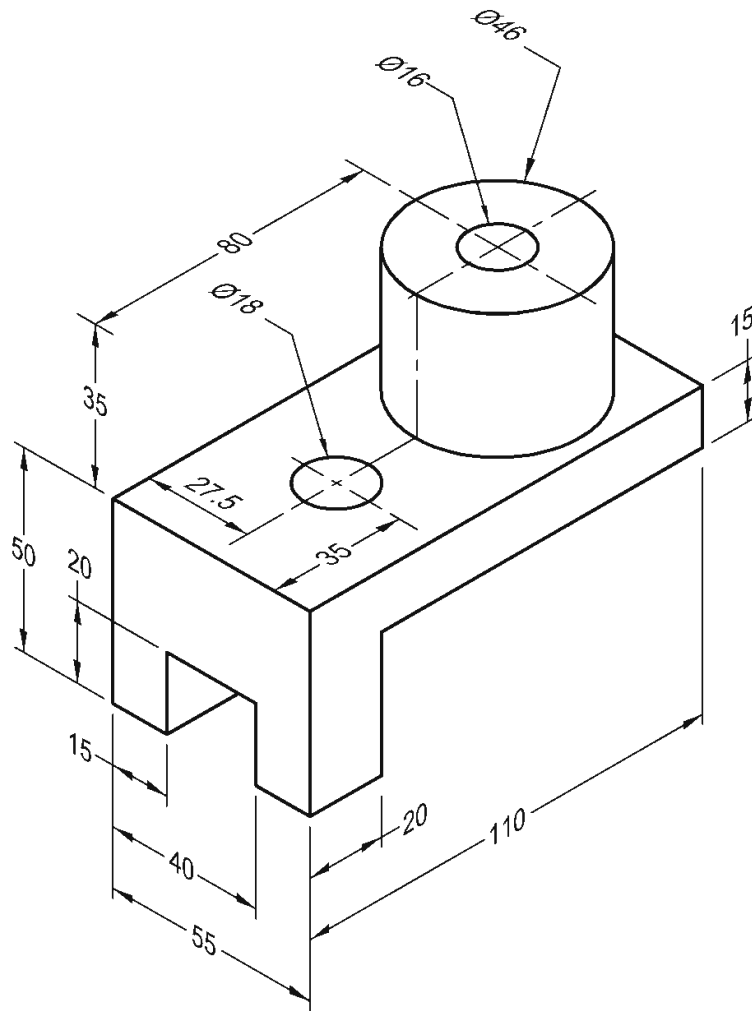

P5-12) Create an orthographic projection of the following object. Draw the three standard views. Dimensions given in inches.

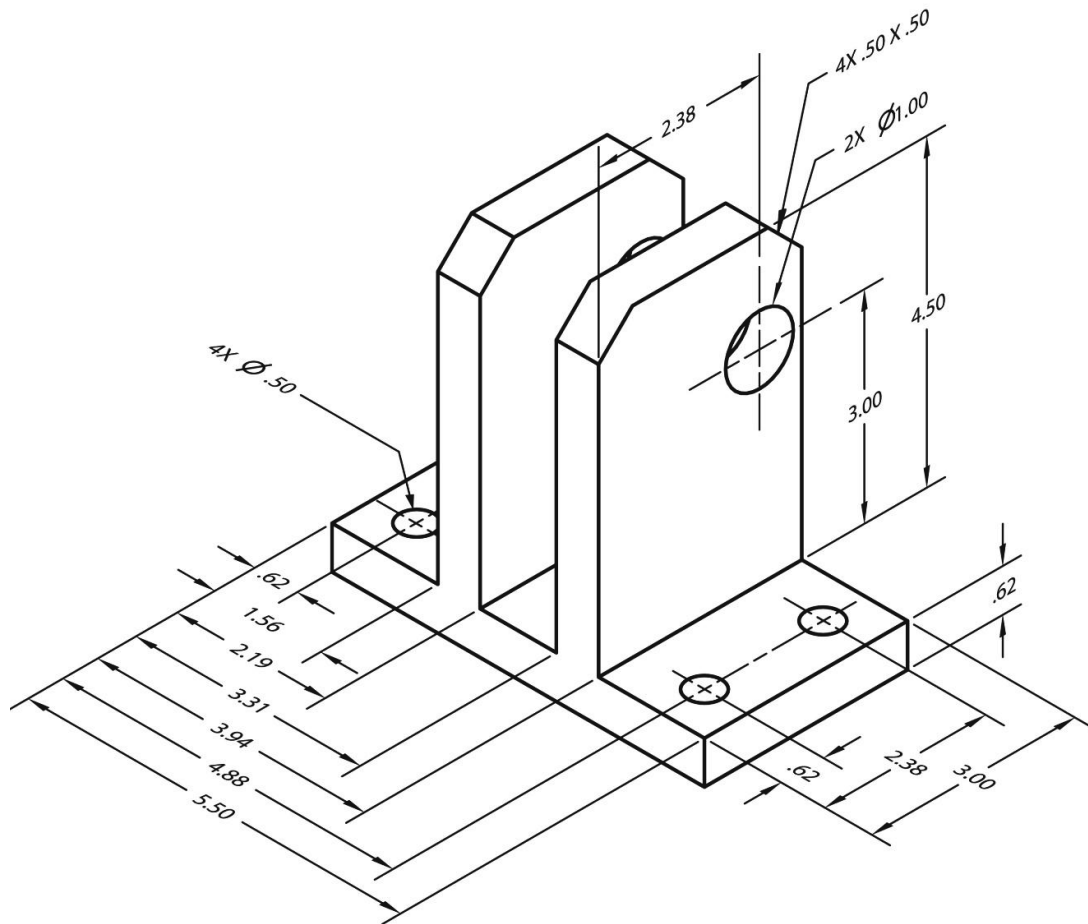

P5-13) Create an orthographic projection of the following object. Draw the three standard views. Dimensions given in inches.

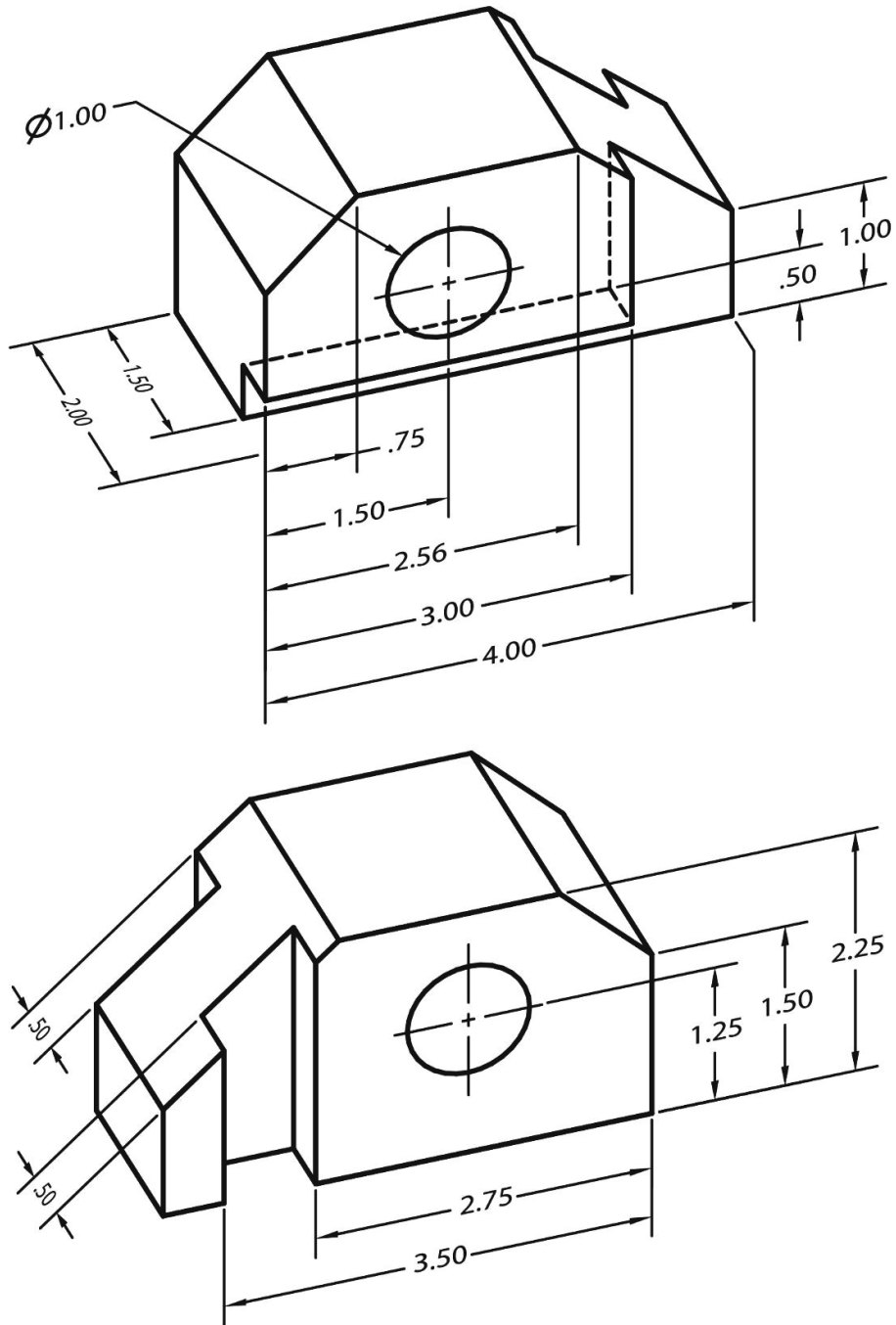

P5-14) Create an orthographic projection of the following object. Draw the three standard views. Dimensions given in millimeters.

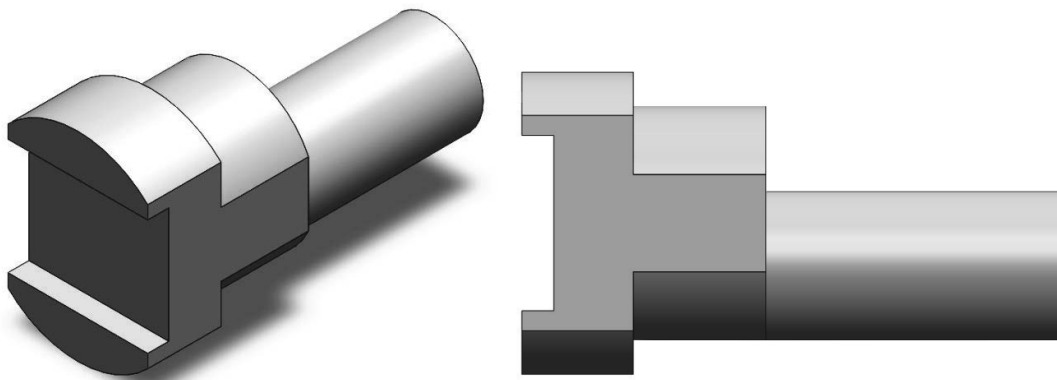
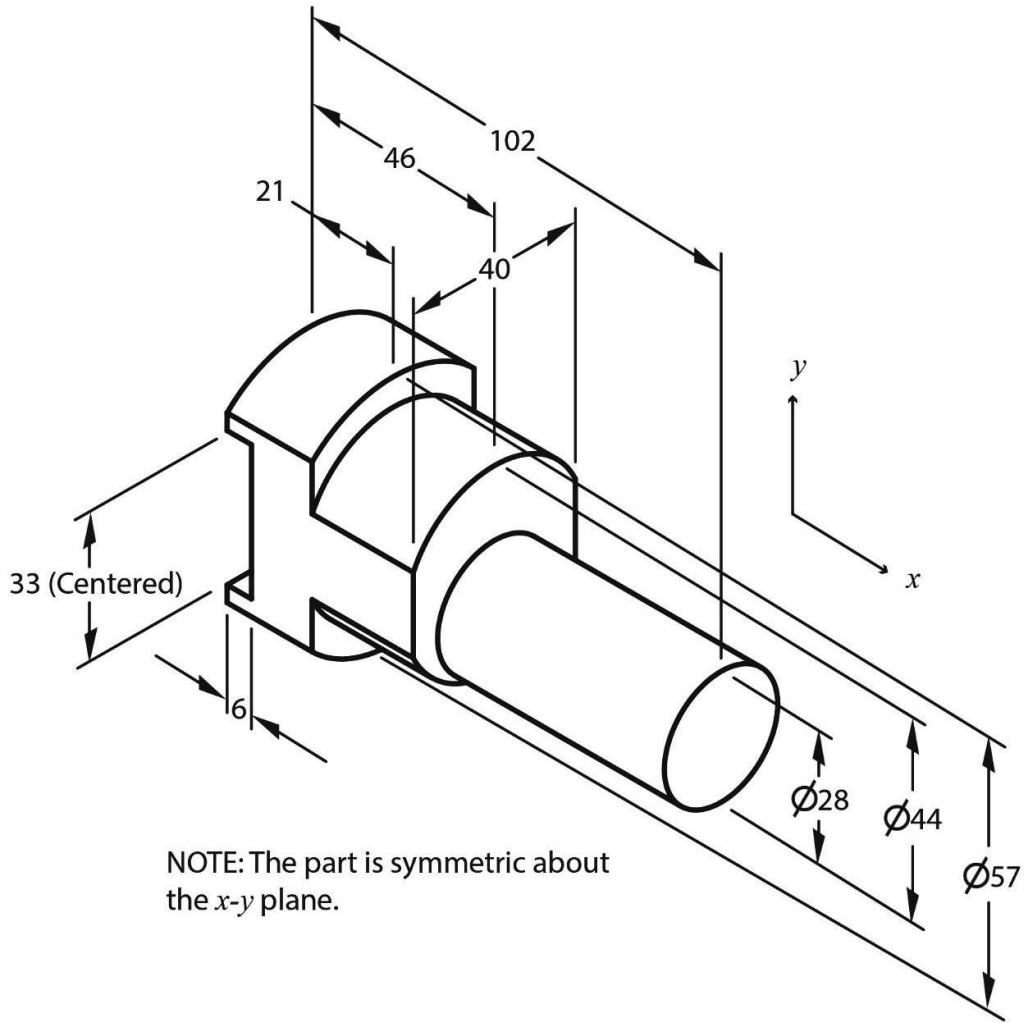

P5-15) Create an orthographic projection of the following object. Draw the three standard views. Dimensions given in inches.

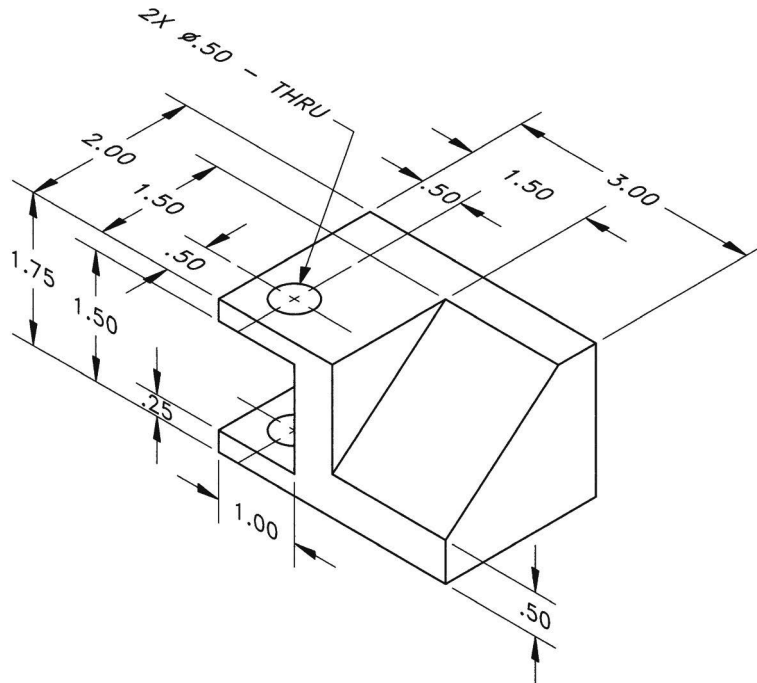

P5-16) Create an orthographic projection of the following object. Draw the three standard views. Dimensions given in millimeters.

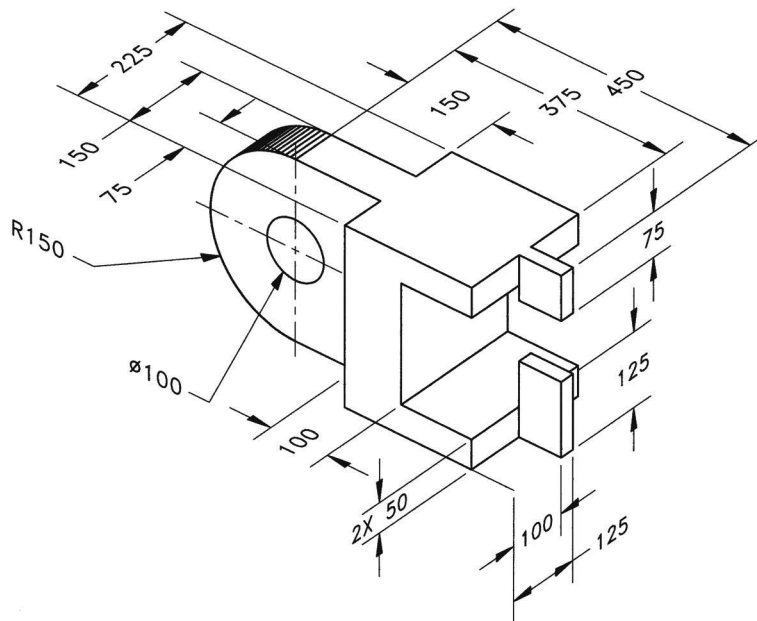

P5-17) Create an orthographic projection of the following object. Draw the three standard views. Dimensions given in millimeters.

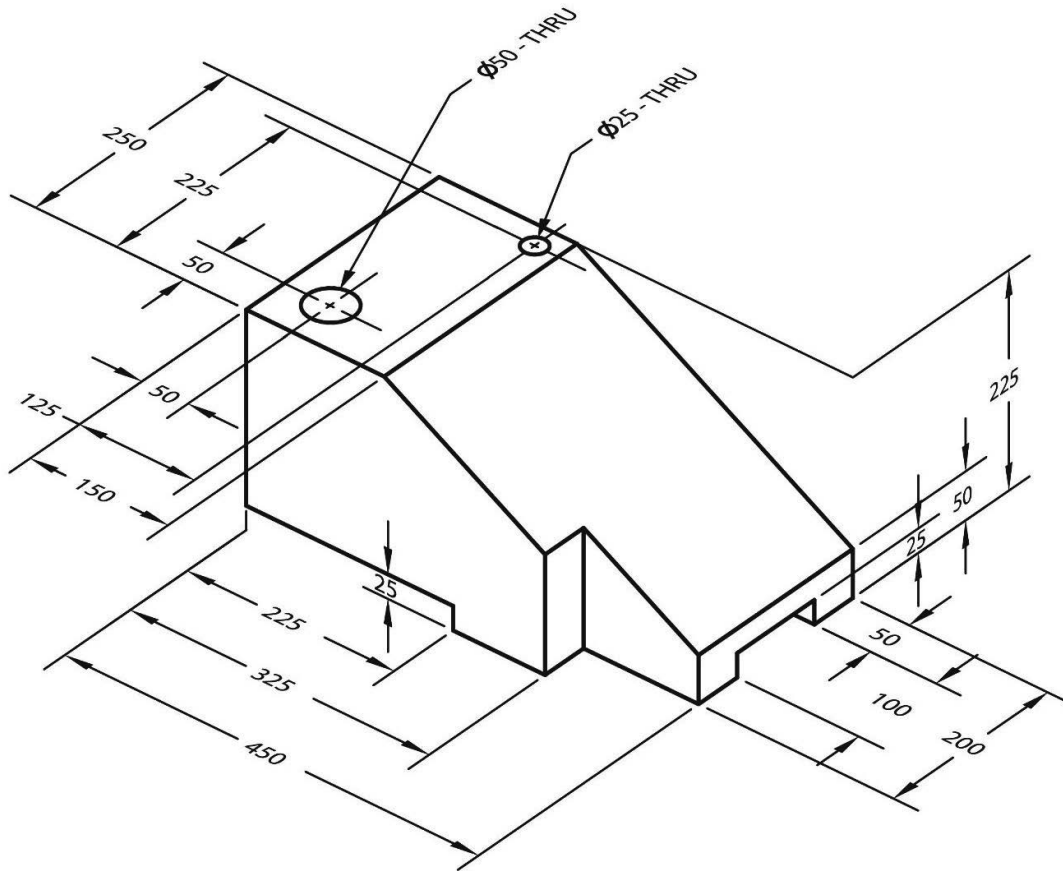

P5-18) Create an orthographic projection of the following object. Draw the three standard views. Dimensions given in inches.

