

INCLUDES
Video presentations and a
digital copy of Technical Drawing

ENGINEERING GRAPHICS

TOOLS FOR THE MIND

A COMPREHENSIVE SET OF ENGINEERING GRAPHICS TOOLS

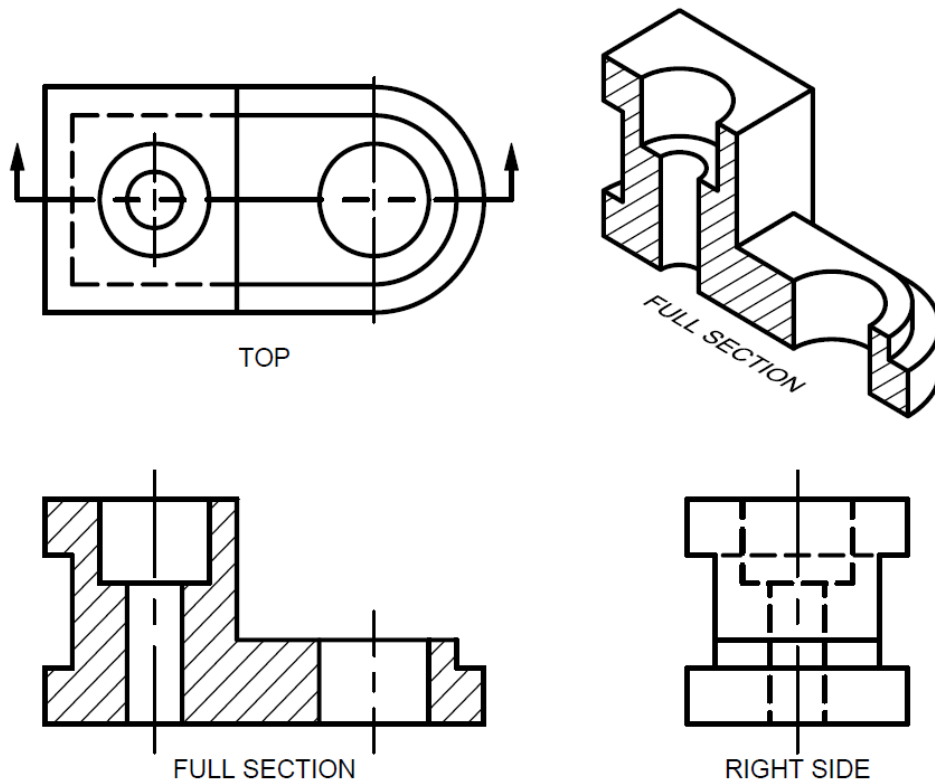

BRYAN GRAHAM

Visit the following websites to learn more about this book:



[amazon.com](https://www.amazon.com)

[BARNES & NOBLE](https://www.barnesandnoble.com)

ENGINEERING GRAPHICS: Tools for the Mind

Bryan Graham

Table of Contents

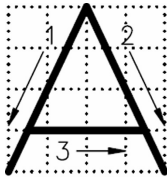

- 1. Lettering**
Guidelines for Lettering

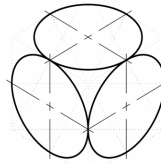

- 2. Sketching**
Lines
Circles
Arcs
Isometric Sketching

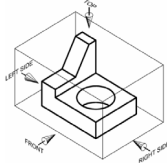

- 3. Orthographic Projection**
Planes and Surfaces
Curved Surfaces

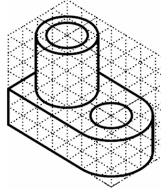

- 4. Isometric Drawings**
Inclined Surface
Oblique Surface
Curved Surfaces

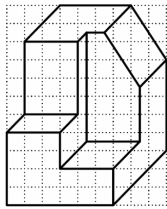

- 5. Oblique Drawings**
Cavalier Oblique
Cabinet Oblique
Curved Surfaces

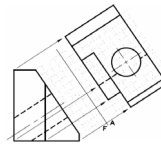

- 6. Auxiliary Views**
Inclined Surface

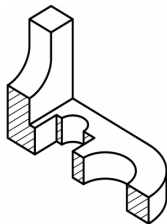

- 7. Sections**
Full Sections
Half Sections
Offset Sections
Revolved/Removed Sections
Broken-Out Sections
Aligned Sections

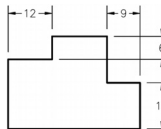

- 8. Dimensioning**
Basic Rules
Size
- Arc Dimension Placement
- Holes and Cylindrical Features
- Machined Holes
Locate
- Finished Surfaces
- Holes or Cylinders on an arc or circle
Overall Dimensions
- Rounded End Objects

Exclusive Bonus Content

Technical Graphics

Meyers • Croft • Miller • Demel • Enders

Ohio State University

Table of Contents

CHAPTER 1 Getting Started

1.1	Introduction	1-1
1.2	What You Will Learn From This Text	1-3
1.2.1	Lettering	1-3
1.2.2	Sketching Techniques	1-3
1.2.3	Shape Description	1-3
	Orthographic Projection	1-3
	Pictorial Drawings	1-4
	Perspective Drawings	1-4
1.2.4	Sections and Conventions	1-4
1.2.5	Size Description	1-4
1.2.6	Fastening and Joining	1-5
1.2.7	Drawing Notes	1-5
1.2.8	Production Drawings	1-5
1.2.9	Descriptive Geometry	1-5
1.2.10	Presentation Graphics	1-7
1.2.11	Computer Systems	1-9
	Computer-aided Manufacturing	1-10
	Computer-integrated Manufacturing	1-11
	Flexible Manufacturing Systems	1-11
1.3	Tools You Will Need	1-12
1.3.1	Tools for Sketching	1-12
1.3.2	Tools for Instrument Drawing	1-13
1.3.3	Drawing by Computer	1-15
	Central Processing Unit	1-15
	Input Devices	1-15
	Output Devices	1-16
	Data Storage Devices	1-16
	Software	1-16
1.4	Using Your Drawing Tools	1-17
1.4.1	Sketching	1-17
1.4.2	Alphabet of Lines	1-17
1.4.3	Instrument Drawing	1-17
	Straight Lines	1-17
	Drawing Straight Lines with Your CAD System	1-19
	Circles and Arcs	1-20
	Drawing Circles and Arcs With Your CAD System	1-20
	Measuring	1-21
	Measuring With Your CAD System	1-22

1.5 Lettering	1-22
1.5.1 Lettering Guidelines	1-23
1.5.2 Lettering Styles	1-23
1.5.3 Character Uniformity	1-24
1.5.4 Spacing	1-24
1.6 Summary	1-25

CHAPTER 2 Technical Sketching

2.1 Introduction	2-1
2.2 Sketching Horizontal Lines	2-2
2.3 Sketching Vertical Lines	2-2
2.4 Sketching Angular Lines	2-2
2.5 Sketching Curved Lines	2-2
2.6 Drawing Media	2-3
2.7 Grids for Sketching	2-3
2.8 Line Weights	2-4
2.9 Sketching Instruments	2-4
2.10 Enlarging and Reducing Using a Grid	2-4
2.11 Enlarging and Reducing Using a Rectangular Diagonal	2-5
2.12 Enlarging and Reducing by Changing the Focal Distance from the Object to the Plane	2-5
2.13 Sketching Small Objects with a Hand for Proportion	2-6
2.14 Sketching Solids	2-6
2.15 Four Steps to Sketching an Object	2-6
2.16 Basic Shading of Solids	2-8
2.17 Orthographic Projection Sketch	2-8
2.18 Isometric Pictorial Sketch	2-9
2.19 Oblique Pictorial Sketch	2-9
2.20 Where Do Ideas Come From That Require Sketching?	2-10
2.21 Sample Engineering Applications	2-11
2.22 Sample Problem: Table Saw Fixture	2-12
2.23 Summary	2-13

CHAPTER 3 Orthographic Projection

3.1 Introduction	3-1
3.1.1 Communicating in Three Dimensions	3-1
3.2 Theory of Orthographic Projection	3-2
3.2.1 First-Angle and Third-Angle Projection	3-3
3.3 Principal Views and Planes	3-4
3.3.1 Front View and the Frontal Plane	3-5
3.3.2 Top View and the Horizontal Plane	3-5

3.3.3	Side View and the Profile Plane	3-5
3.3.4	Other Principal Views and Planes	3-5
3.3.5	Relation of the Principal Views	3-6
3.4	Principal Dimensions	3-7
3.5	Nonlinear Features	3-7
3.5.1	Center Lines	3-8
3.6	Visibility	3-8
3.6.1	Describing Hidden Features	3-8
3.7	The Alphabet of Lines	3-9
3.7.1	Visible Lines	3-9
3.7.2	Dashed Lines for Hidden Features	3-9
3.7.3	Junctions of Lines	3-10
3.7.4	Center Lines	3-10
3.7.5	Construction Lines	3-10
3.7.6	Precedence of Lines	3-11
3.8	Using Subscripts	3-11
3.9	What a Line Represents	3-12
3.9.1	A Line as the Edge View of a Surface	3-12
3.9.2	A Line as an Intersection	3-12
3.9.3	A Line as a Limiting Element	3-12
3.9.4	What Can a Line Represent?	3-12
3.10	What a Point Represents	3-13
3.10.1	A Point as the Intersection of Lines	3-13
3.10.2	What Can a Point Represent?	3-13
3.11	Reading the Surfaces of Objects	3-14
3.11.1	Surfaces That Are True Size and Shape	3-14
3.11.2	Surfaces That Are Inclined	3-14
3.11.3	Surfaces That Are Oblique	3-15
3.11.4	Reading by Sketching	3-15
3.11.5	Curved and Tangent Surfaces	3-16
3.11.6	Conventional Practices	3-16
3.11.7	Fillets, Rounds, and Runouts	3-17
3.12	Keys to Reading Three-Dimensional Objects	3-18
3.12.1	Identify and Locate Points on the Object	3-18
3.12.2	Identify and Locate Lines on the Object	3-19
3.12.3	Identify and Locate Surfaces on the Object	3-19
3.12.4	Curved Surfaces and Limiting Elements	3-20
3.12.5	Reading an Object by Sketching It	3-20
3.12.6	Reading by Modeling the Object	3-20
3.13	Creating a Multiview Orthographic Drawing	3-21
3.13.1	Choice of Views	3-22
3.13.2	Planning a Drawing	3-22
3.13.3	Developing the Drawing	3-23
3.13.4	Checking Your Work	3-24
3.14	Creating a Drawing on the Computer	3-24
3.14.1	Selecting a Grid	3-24
3.14.2	Selecting the Layers	3-25
3.14.3	Selecting Pen Widths and Colors for a Printer	3-25
3.14.4	Developing the Drawing on the Computer	3-25
	Construction Lines	3-25
	Visible Lines	3-26

	Finishing the Drawing	3-26
	Alternate Methods for Layering	3-26
3.14.5	Modeling With CAD	3-28
3.15	Auxiliary Views	3-29
	3.15.1 Preparing an Auxiliary View Drawing	3-30
	3.15.2 Other Auxiliary Views	3-32
3.16	Sample Problem: Table Saw Fixture	3-32
3.17	Summary	3-33

CHAPTER 4 Pictorial Drawings

4.1	Introduction	4-1
4.2	Axonometric Drawings	4-1
	4.2.1 Types of Axonometric Drawings	4-1
	4.2.2 The Isometric Axes	4-2
	4.2.3 Normal Surfaces in Isometric	4-2
	4.2.4 Inclined Surfaces in Isometric	4-3
	4.2.5 Oblique Surfaces in Isometric	4-4
	4.2.6 Circles and Arcs Using an Isometric Template	4-4
	4.2.7 Sketching and Drawing Circles and Arcs	4-6
	4.2.8 Sketching or Drawing Ellipses on Non-isometric Surfaces	4-8
	4.2.9 Sketching an Irregular Ellipse or Curve	4-9
	4.2.10 Exploded Views	4-9
	4.2.11 Isometric Assembly Sketches and Drawings	4-10
	4.2.12 Isometric Projections	4-10
4.3	Oblique Drawings	4-12
	4.3.1 Oblique Views	4-12
	4.3.2 Cabinet and Cavalier Oblique Drawings	4-13
4.4	Perspective Drawings	4-14
	4.4.1 Perspective Overview	4-14
	4.4.2 One-Point Perspective	4-14
	4.4.3 Two-Point Perspective	4-16
	4.4.4 Layout of the Object and Picture Plane	4-17
	4.4.5 The Measuring Line	4-18
	4.4.6 The Horizon	4-19
	4.4.7 The Station Point	4-20
	4.4.8 Vanishing Points	4-20
	4.4.9 Projectors	4-20
	4.4.10 Visual Rays	4-21
	4.4.11 Presentation Variables	4-22
	4.4.12 Angular Surfaces	4-22
	4.4.13 Curved Surfaces	4-23
	4.4.14 Three-Point Perspective	4-25
4.5	Computer Applications	4-25
4.6	Sample Problem: Table Saw Fixture	4-25
4.7	Summary	4-25

CHAPTER 5 Sections and Conventions

5.1	Introduction	5-1
5.2	Cutting Plane	5-1

5.3	Section Lines	5-3
5.4	Full Section	5-5
5.5	Half Sections	5-6
5.6	Offset Sections	5-7
5.7	Revolved Sections	5-7
5.8	Removed Sections	5-7
5.9	Broken-out Sections	5-8
5.10	Sectioned Assemblies	5-8
5.11	Sectioned Isometric Drawings	5-8
5.12	Conventional Breaks	5-9
5.13	Conventional Revolutions	5-9
5.13.1	Conventional Hole Revolutions	5-10
5.13.2	Conventional Rib Revolutions	5-10
5.13.3	Conventional Spoke Revolutions	5-11
5.13.4	Conventional Lug Revolutions	5-12
5.13.5	Hole, Rib, Spoke, and Lug Combination	5-12
5.13.6	Alternate Crosshatching	5-13
5.14	Sample Problem: Table Saw Fixture	5-13
5.15	Summary	5-13

CHAPTER 6 Dimensions and Tolerances

6.1	Introduction	6-1
6.1.1	Dimensioning Standards	6-1
6.1.2	Dimensioning Practices	6-2
6.2	Scaling and Dimensions	6-2
6.2.1	Types of Scales	6-3
6.2.2	Specifying Scales on a Drawing	6-5
6.3	Dimensioning Basic Shapes	6-5
6.3.1	Assumptions	6-5
Perpendicularity	6-5	
Symmetry	6-5	
6.3.2	Simple Shapes	6-5
Rectangular Prisms	6-5	
Cylinders	6-5	
Cone and Frustum	6-6	
6.3.3	Simple Curved Shapes	6-6
6.3.4	Circular Center Lines	6-7
6.4	Placement of Dimensions	6-8
6.4.1	Characteristic View	6-8
6.4.2	Dimensions Should Be Grouped	6-8
6.4.3	Preferred Locations	6-8
6.5	Dimensioning Systems	6-8
6.5.1	Alignment of Dimension Numbers	6-8
6.5.2	Units of Measurement	6-9
6.6	Standard Practices	6-9
6.6.1	Lines for Dimensioning	6-9

6.6.2	Arrowheads	6-9
6.6.3	Lettering and Notes	6-10
6.6.4	Readability	6-10
6.7	Planning and Layout	6-11
6.8	Functional Relationships	6-11
6.8.1	Tolerance Accumulation	6-11
6.8.2	Dimensioning to Finished Surfaces	6-12
6.8.3	Dimensions for Locating Features on an Object	6-13
6.8.4	Procedure for Functional Dimensioning	6-14
6.9	Dimensioning on the Computer	6-14
6.9.1	A Layer for Dimensions	6-14
6.9.2	Scaling a CAD Drawing	6-14
6.9.3	Automatic Dimensioning	6-15
6.10	Other Standard Dimensioning Systems	6-15
6.10.1	Datum Lines and Surfaces	6-16
6.10.2	Tabular Dimensioning	6-16
6.10.3	Other Design Disciplines	6-17
6.11	Dimensioning for Interchangeable Parts	6-18
6.11.1	Types of Fits	6-18
	Clearance Fits	6-19
	Checking Fit Calculations	6-19
	Interference Fits	6-20
	Transition Fits	6-20
6.11.2	Standard Fits	6-20
6.11.3	Cylindrical Fits	6-21
	Basic Hole System	6-21
	Basic Shaft System	6-22
6.12	Advanced Dimensioning Topics	6-23
6.12.1	Metric Dimensioning With International Standards	6-23
6.12.2	Surface Control	6-23
6.12.3	Geometric Tolerancing	6-23
6.13	Principles of Good Dimensioning	6-23
6.14	Checking a Dimensioned Drawing	6-28
6.15	Sample Problem: Table Saw Fixture	6-28
6.16	Summary	6-29

CHAPTER 7 Dimensioning for Production

7.1	Introduction	7-1
7.2	Manufacturing Processes	7-2
7.2.1	Material Reformation	7-2
7.2.2	Material Removal	7-3
7.2.3	Material Addition	7-5
7.2.4	Assembly Processes	7-6
7.3	Standard Tables for Fits	7-7
7.3.1	Preferred Limits and Fits in Inches	7-7
7.3.2	Preferred Metric Limits and Fits	7-9
7.4	Surface Control	7-11
7.5	Geometric Tolerancing	7-14

7.5.1	Definitions and Symbols	7-15
7.5.2	Datum Referencing	7-16
7.5.3	Tolerances of Location	7-17
7.5.4	Tolerances of Form	7-19
7.6	Sample Problem: Table Saw Fixture	7-22
7.7	Summary	7-22

CHAPTER 8 Fastening, Joining, and Standard Parts

8.1	Introduction	8-1
8.2	Screw-Thread Terms	8-2
8.3	Other Properties of Threads	8-3
8.3.1	Right-hand and Left-hand Threads	8-3
8.3.2	Screw-Thread Forms	8-3
8.3.3	Multiple Threads	8-4
8.3.4	Thread Series	8-5
8.3.5	Specifying a Thread	8-6
8.4	Threaded Fasteners	8-7
8.4.1	Screws	8-7
8.4.2	Bolts, Nuts, Studs, and Washers	8-9
8.4.3	Materials for Fasteners	8-11
8.5	Representing Threads and Fasteners on Drawings	8-11
8.5.1	Detailed Thread Symbols	8-12
8.5.2	Schematic Thread Symbols	8-13
8.5.3	Simplified Thread Symbols	8-14
8.5.4	Drawing Screw Heads and Nuts	8-14
8.5.5	Specifying Fasteners	8-15
8.6	Other Mechanical Fasteners	8-15
8.6.1	Rivets	8-16
8.6.2	Pins	8-16
8.6.3	Keys	8-17
8.6.4	Retaining Rings	8-18
8.7	Other Machine Elements	8-18
8.8	Thermal Processes	8-20
8.8.1	Welding Processes	8-20
8.8.2	Specifying Welds on Drawings	8-22
8.8.3	Soldering and Brazing	8-23
8.9	Adhesives	8-24
8.9.1	Principal Types of Adhesives	8-24
8.10	The Future of Fastening and Joining	8-25
8.11	Sample Problem: Table Saw Fixture	8-26
8.12	Summary	8-26

CHAPTER 9 Production Drawings

9.1	Introduction	9-1
9.2	Applications of Production Drawings	9-12
9.3	Types of Production Drawings	9-12

9.3.1	Orthographic Detail Drawings	9-12
9.3.2	Sectioned Assembly Drawings	9-13
9.3.3	Pictorial Drawings and Diagrams	9-14
9.3.4	Drawings for Other Disciplines	9-16
9.4	Callouts	9-19
9.5	Identification of Measuring Units	9-19
9.6	Paper Sizes for Drawings	9-20
9.7	Title Blocks	9-21
9.8	Revisions	9-24
9.9	Parts List	9-24
9.10	General Notes	9-25
9.11	Applications of the CAD Database	9-26
9.12	Flow of Information	9-29
9.13	Accompanying Written Specifications	9-30
9.14	Sample Problem: Table Saw Fixture	9-30
9.15	Summary	9-31

CHAPTER 10 Three-Dimensional Geometry Concepts

10.1	Introduction	10-1
10.2	Applications of Descriptive Geometry	10-8
10.2.1	Problem-solving Skills	10-9
10.2.2	Developing Visualization Skills	10-10
10.3	Operations	10-10
10.3.1	The Direct Method	10-10
10.3.2	The Glass Box: Fold Line Method	10-13
10.4	Line Relationships	10-15
10.4.1	Principal Lines	10-15
10.4.2	Inclined Lines	10-15
10.4.3	Oblique Lines	10-15
10.4.4	Parallel Lines	10-18
10.4.5	Perpendicular Lines	10-19
10.4.6	Angular Relationships	10-20
10.4.7	Applications	10-21
10.5	Plane and Line Relationships	10-22
10.5.1	Principal Planes	10-22
10.5.2	Inclined Planes	10-22
10.5.3	Oblique Planes	10-27
10.5.4	Lines Parallel to Planes	10-29
10.5.5	Lines Perpendicular to Planes	10-30
10.5.6	Angles between Lines and Planes	10-30
10.5.7	Lines Intersecting Planes	10-33
10.5.8	Planes Parallel to Planes	10-34
10.5.9	Dihedral Angles	10-34
10.5.10	Planar Intersections	10-35
10.5.11	Plane-Solid Intersections	10-36
10.5.12	Solid-Solid Intersections	10-39

10.6	Curved Surfaces	10-40
10.6.1	Line-Cylinder Intersections	10-43
10.6.2	Line-Cone Intersections	10-44
10.6.3	Line-Sphere Intersections	10-45
10.6.4	Plane-Cylinder Intersections	10-45
10.6.5	Plane-Cone Intersections	10-46
10.6.6	Cylinder-Cylinder Intersections	10-47
10.6.7	Cylinder-Right Circular Cone Intersection	10-48
10.7	Sample Problem: Table Saw Fixture	10-49
10.8	Summary	10-50

CHAPTER 11 3-D Geometry Applications

11.1	Introduction	11-1
11.2	Pattern Developments	11-1
11.2.1	Principles and Examples	11-1
11.2.2	Right Solids	11-2
11.2.3	Cylinders	11-6
11.2.4	Cones	11-10
11.2.5	Pyramids and Tetrahedrons	11-11
11.2.6	Transition Pieces	11-12
11.2.7	Models From Intersecting Solids	11-13
11.2.8	Applications	11-16
11.3	Maps and Contour Plots	11-16
11.3.1	Map Introduction	11-17
11.3.2	Concept of Representing Elevation	11-22
11.3.3	Sections or Profiles and Applications	11-22
11.4	Vector Graphics	11-23
11.4.1	Vector Addition and Subtraction	11-24
11.4.2	Applications	11-25
	Statics: Two-Dimensional, Single-Joint Problem	11-25
	Statics: Two-Dimensional Truss Analysis	11-27
	Statics: Three-Dimensional Analysis	11-27
11.5	Shades and Shadows	11-28
11.5.1	Shade, Shadows, and the Standard Light Ray	11-28
11.5.2	Orthographic Views	11-29
11.5.3	Shades and Shadows in Isometric Pictorials	11-37
11.5.4	Shades and Shadows in Perspective Pictorials	11-40
11.6	Sample Problem: Table Saw Fixture	11-42
11.7	Summary	11-42

CHAPTER 12 Graphical Presentation of Data

12.1	Introduction	12-1
12.2	Charts and Graphs	12-1
12.2.1	Classes of Charts and Graphs	12-1
12.2.2	Typical Uses of Charts and Graphs	12-2
12.2.3	Types of Graphs and Their Uses	12-4
	Line Graphs	12-4
	Multiple-Line Graphs	12-5
	Multiple-Scale Graphs	12-5

	Pie Charts	12-6
	Polar Charts	12-7
	Bar Charts	12-8
	Surface Charts	12-9
	Three-Coordinate Charts	12-9
	Tri-linear Charts	12-10
12.2.4	Plotting a Graph	12-11
	Selecting the Type of Graph	12-11
	Selecting a Size for a Graph	12-11
	Selecting and Calibrating a Scale	12-12
12.2.5	Adding Titles and Labels	12-14
	Chart/Graph Title	12-14
	Labeling the Axes	12-15
12.2.6	Modeling Empirical Data (Data Scatter)	12-16
	Best-Fit Methods	12-16
	Types of Data	12-17
12.2.7	Computer-based Chart and Graph Programs	12-17
12.3	Merging Text and Graphics by Computer	12-20
12.4	Sample Problem: Table Saw Fixture	12-23
12.5	Summary	12-23

CHAPTER 13 Design Process

13.1	Introduction	13-1
	13.1.1 Product Design and Systems Design	13-2
13.2	Scientific Method	13-4
	13.2.1 Determine a Need	13-5
	13.2.2 Establish Known Information	13-6
	13.2.3 Stimulate Design Concepts	13-6
	13.2.4 Investigate Design Concepts With Analytical Tools	13-7
	13.2.5 Gather and Review Investigation Data	13-8
	13.2.6 Now Test the Design	13-8
	13.2.7 Propose to Accept, Modify, or Reject the Design	13-9
	13.2.8 Render the Final Decision and Prepare Working Drawings	13-10
	13.2.9 Optimize Design by Iteration	13-10
13.3	Lateral Thinking	13-11
13.4	Presentation	13-12
	13.4.1 What Is Being Presented?	13-12
	13.4.2 Why Is the Presentation Being Made?	13-12
	13.4.3 Who Is the Audience?	13-13
	13.4.4 When Will the Presentation Be Made?	13-13
	13.4.5 Where Will the Presentation Be Made?	13-13
	13.4.6 How Will the Information Be Presented?	13-14
	13.4.7 How Much Will the Presentation Cost?	13-14
	13.4.8 Notes on Content of Presentations	13-14
13.5	Protection of Designs	13-15
13.6	A Design Problem	13-16
	13.6.1 Determine a Need	13-16
	13.6.2 Establish Known Information	13-16
	13.6.3 Stimulate Design Concepts	13-18
	13.6.4 Investigate Design Concepts With Analytical Tools	13-20
	13.6.5 Gather and Review Investigation Data	13-22

13.6.6	Now Test the Design	13-22
13.6.7	Propose to Accept, Modify, or Reject the Design	13-23
13.6.8	Render the Final Decision	13-24
13.6.9	Optimize Design by Iteration	13-25
13.7	Summary	13-26

APPENDIX Tables

Table A.1	Preferred Limits and Fits (Inches)	A-3
Table A.2	Preferred Limits and Fits (Metric)	A-10
Table A.3	American National Standard Unified Inch Screw Threads	A-14
Table A.4	Standard Coarse Pitch Metric Threads	A-15
Table A.5	Standard Fine Pitch Metric Threads	A-15
Table A.6	Dimensions of Hex Bolts	A-16
Table A.7	Dimensions of Square Bolts	A-17
Table A.8	Dimensions of Hex Nuts and Hex Jam Nuts	A-18
Table A.9	Dimensions of Square Nuts	A-19
Table A.10	Dimensions of Hex Cap Screws	A-20
Table A.11	Dimensions of Slotted Flat Countersunk Head Cap Screws	A-21
Table A.12	Dimensions of Slotted Round Head Cap Screws	A-22
Table A.13	Dimensions of Slotted Fillister Head Cap Screws	A-23
Table A.14	Dimensions of Hex Head Machine Screws	A-24
Table A.15	Dimensions of Slotted Flat Countersunk Head Machine Screws	A-25
Table A.16	Dimensions of Slotted Fillister Head Machine Screws	A-26
Table A.17	Dimensions of Square and Hex Machine Screw Nuts	A-27
Table A.18	Dimensions of Slotted Headless Set Screws	A-28
Table A.19	Dimensions of Square Head Set Screws	A-29
Table A.20	Shoulder Screws	A-30
Table A.21	Dimensions of Preferred Sizes of Type A Plain Washers	A-31
Table A.22	Dimensions of Woodruff Keys	A-32
Table A.23	Tap Drill Sizes – Inches	A-33
Table A.24	Tap Drill Sizes – Metric	A-33
Table A.25	Standard Welding Symbols	A-34
Table A.26	Fraction – Decimal Conversion Table	A-36